



Heating and Air Conditioning

TECHNICAL GUIDE

SPLIT-SYSTEM AIR CONDITIONERS

10 SEER

MODELS:

H*RA018 THRU 060

(1.5 THRU 5 NOMINAL TONS, 1 PH)

H*RA036 THRU 090

(3 THRU 7.5 NOMINAL TONS, 3 PH)



MODELS: 018 - 060 (1 PH & 3 PH)



MODELS: 076 - 090 (3 PH)



CERTIFICATION APPLIES ONLY
WHEN THE COMPLETE
SYSTEM IS LISTED
WITH ARI.



Due to continuous product improvement, specifications are subject to change without notice.

Visit us on the web at www.york.com for the most up-to-date technical information.

Additional rating information can be found at www.ariprimer.net.org.

DESCRIPTION

The 10 SEER Series condensing unit is the outdoor part of a versatile system of air conditioning. It is designed to be custom-matched with one of UPG's complete line of evaporator sections, each designed to serve a specific function. Matching Air Handlers are available for upflow, downflow or horizontal applications to provide a complete system. Electric Heaters are available if required. Add-On coils are available for use with upflow, downflow or horizontal furnaces and air handlers.

WARRANTY

Single Phase Units:

5-year limited parts warranty.

5-year limited compressor warranty.

Three Phase Units:

1-year limited parts warranty.

5-year limited compressor warranty.

FEATURES

- **QUALITY CONDENSER COILS** - The coil is constructed of enhanced copper tube and aluminum fins.
- **COIL PROTECTION** - Coils are protected from damage by a polymer mesh applied between the coil face, and a PVC coated steel coil guard.
- **PROTECTED COMPRESSOR** - The compressor is internally protected against high pressure and temperature. This is accomplished by the simultaneous operation of high pressure relief valve and a temperature sensor which protects the compressor if undesirable operating conditions occur. A liquid line filter-drier further protects the compressor.
- **DURABLE FINISH** - The cabinet is made of pre-painted steel. The pre-treated flat galvanized steel provides a better paint to steel bond, which resists corrosion and rust creep. Special primer formulas and matted desert sand finish insure less fading when exposed to sunlight.
- **LOWER INSTALLED COST** - Installation time and costs are reduced by easy power and control wiring connections. Discharge line heat exchanger knockouts are provided, if required. Available in sweat connect models only. The unit contains enough refrigerant for matching indoor coils and 15 feet of interconnecting piping. The small base dimension means less space is required on the ground or roof.
- **TOP DISCHARGE** - The warm air from the top mounted fan is blown up away from the structure and any landscaping. This allows compact location on multi-unit applications.
- **LOW OPERATING SOUND LEVEL** - The upward air flow carries the normal operating noise up away from the living area. The rigid top panel effectively isolates any motor sound. Isolator mounted compressor and the rippled fins of the condenser coil muffle the normal fan motor and compressor operating sounds.
- **LOW MAINTENANCE** - Long life permanently lubricated motor-bearings need no annual servicing.
- **EASY SERVICE ACCESS** - Fully exposed refrigerant connections, a single panel covering the electrical controls and the mox plug in the control box connecting the condenser fan, make for easy servicing of the unit.
- **SECURED SERVICE VALVES** - Secured re-usable service valves are provided on both the liquid and vapor sweat connections for ease of evacuating and charging.
- **U.L. and C.U.L. listed** - approved for outdoor application.

Certified in accordance with the Unitary Small Equipment certification program, which is based on ARI Standard 210/240.

Physical and Electrical Data - 1 Phase

MODEL		H1RA018S06	H1RA024S06	H2RA030S06	H2RA036S06	H1RA042S06	H1RA048S06	H3RA060S06
Unit Supply Voltage		208/230 – 1 – 60						
Normal Voltage Range ¹		187 to 252						
Minimum Circuit Ampacity		12.5	15.6	17.5	21.5	26.1	30.1	37.3
Max. Overcurrent Device Amps ²		20	25	30	35	40	45	60
Compressor Type ³		Recip	Recip	Recip	Recip	Recip	Recip	Scroll ^B
Compressor Amps	Rated Load	9.6	12.1	13.6	16.1	19.8	23	28.8
	Locked Rotor	54	57	73	82	97	110	160
Crankcase Heater		No	No	No	No	No	No	No
Fan Motor Amps	Rated Load	0.5	0.5	0.5	1.4	1.4	1.3	1.3
Fan Diameter Inches		18	18	18	18	18	22	22
Fan Motor	Rated HP	1/12	1/12	1/12	1/4	1/4	1/4	1/4
	Nominal RPM	1,100	1,100	1,100	1,100	1,100	850	850
	Nominal CFM	1,850	1,850	1,900	2,750	2,750	3,250	3,300
Coil	Face Area Sq. Ft.	8.00	8.00	9.15	9.15	12.58	15.72	15.72
	Rows Deep	1	1	1	1	1	1	1
	Fin / Inches	14	14	18	18	18	18	22
Liquid Line OD		3/8	3/8	3/8	3/8	3/8	3/8	3/8
Vapor Line OD		5/8	5/8	3/4	3/4	3/4	7/8	7/8
Unit Charge (Lbs. - Oz.) ⁴		3 - 6	3 - 11	3 - 14	3 - 15	5 - 4	7 - 5	6 - 2
Charge Per Foot, Oz. ⁴		0.66	0.66	0.68	0.68	0.68	0.70	.070
Operating Weight Lbs.		118	123	135	137	161	176	188

Physical and Electrical Data - 3 Phase

MODEL		H1RA 036S25	H1RA 042S25	H1RA 048S25	H1RA 060S25	H1RA 076S25	H1RA 090S25	H1RA 036S46	H1RA 042S46	H1RA 048S46	H1RA 060S46	H1RA 076S46	H1RA 090S46
Unit Supply Voltage		208/230 – 3 – 60						460 - 3 - 60					
Normal Voltage Range ¹		187 to 252						432 to 504					
Minimum Circuit Ampacity		15.0	17.4	17.3	21.3	25.8	37.7	8.0	8.4	8.3	10.8	13.0	18.1
Max. Overcurrent Device Amps ²		25	30	30	35	40	50	15	15	15	15	20	25
Compressor Type ³		Recip	Recip	Recip	Scroll ^B	Scroll ^B	Dual	Recip	Recip	Recip	Scroll ^B	Scroll ^B	Dual
Compressor Amps	Rated Load	10.9	12.8	11.7	16.0	18.9	29.4	5.8	6.1	6.1	8.0	9.5	14.0
	Locked Rotor	78	78	78	125	146	260	40	39	39	67	73	128
Crankcase Heater		No	No	No	No	No	Yes	No	No	No	No	No	Yes
Fan Motor Amps	Rated Load	1.4	1.4	1.3	1.3	2.2	4.6	.8	.8	.7	.8	1.2	2.3
Fan Diameter Inches		18	18	22	22	24	24	18	18	22	22	24	24
Fan Motor	Rated HP	1/4	1/4	1/4	1/4	1/3	3/4	1/4	1/4	1/5	1/4	1/3	3/4
	Nominal RPM	1,100	1,100	850	850	1100	1100	1,100	1,100	850	850	1100	1100
	Nominal CFM	2,750	2,750	3,250	3,450	4000	5000	2,750	2,750	3,250	3,450	4000	5000
Coil	Face Area Sq. Ft.	9.15	12.58	15.72	23.58	18.0	22.5	9.15	12.58	15.72	23.58	18.0	22.5
	Rows Deep	1	1	1	1	2	2	1	1	1	1	2	2
	Fin / Inches	18	18	18	18	16	16	18	18	18	18	16	16
Liquid Line OD		3/8	3/8	3/8	3/8	1/2	1/2	3/8	3/8	3/8	3/8	1/2	1/2
Vapor Line OD		3/4	3/4	7/8	7/8	1-1/8	1-1/8	3/4	3/4	7/8	7/8	1-1/8	1-1/8
Unit Charge (Lbs. - Oz.) ⁴		3 - 15	5 - 4	7 - 5	9 - 7	12-3	15-3	3 - 15	5 - 4	7 - 5	9 - 7	12-3	15-3
Charge Per Foot, Oz. ⁴		.68	.68	.70	.70	1.26	1.26	.68	.68	.70	.70	1.26	1.26
Operating Weight Lbs.		170	176	206	228	219	368	170	176	206	228	219	368

1. Rated in accordance with ARI Standard 110, utilization range "A".

2. Dual element fuses or HACR circuit breaker.

3. All scrolls listed with a superscript "B" are Bristol scrolls. All scrolls listed with a superscript "C" are Copeland scrolls.

4. The Unit Charge is correct for the outdoor unit, matched indoor coil and 15 feet of refrigerant tubing. For tubing lengths other than 15 feet, add or subtract the amount of refrigerant, using the difference in length multiplied by the per foot valve.

COOLING CAPACITY - With Air Handler Coils

UNIT MODEL	AIR HANDLER			COIL ¹ MODEL	COOLING					
	MODEL	ELECTRIC ² HEAT KW	W		RATED CFM	NET MBH		SEER W/O TXV	SEER + TXV ³	EER
						TOTAL	SENS.			
1 PH 10 SEER AC WITH N1AH / G2FD										
H1RA018S06	N1AHB0806	2,5,8,10	17	G2FD024S17	650	19.0	14.1	10.50	-	9.80
H1RA024S06	N1AHB0806	2,5,8,10	17	G2FD024S17	800	24.4	18.1	10.50	-	9.55
	N1AHB0806	2,5,8,10	17	G2FD030S17	850	25.0	18.5	10.60	-	9.65
H2RA030S06	N1AHB1206	5,8,10,15,19	17	G2FD030S17	1000	29.0	21.5	10.30	-	9.45
	N1AHB1206	5,8,10,15,19	17	G2FD036S17	1000	30.0	22.2	10.50	-	9.65
H2RA036S06	N1AHB1206	5,8,10,15,19	17	G2FD036S17	1200	33.8	25.0	10.00	-	9.20
	N1AHB1206	5,8,10,15,19	17	G2FD046S17	1200	34.4	25.5	10.15	-	9.30
H1RA042S06	N1AHC1606	5,8,10,15,20	21	G2FD042S21	1400	39.5	29.2	10.00	-	9.00
	N1AHC1606	5,8,10,15,20	21	G2FD048S21	1450	41.0	30.3	10.10	-	9.15
H1RA048S06	N1AHC1606	5,8,10,15,20	21	G2FD048S21	1600	46.0	34.0	10.10	-	9.50
	N1AHD2006	8,10,15,20,25,30	24	G2FD060S24	1600	47.0	34.8	10.40	-	9.70
H3RA060S06	N1AHD2006	8,10,15,20,25,30	24	G2FD060S24	1800	56.0	40.2	10.50	-	9.35
3 PH 10 SEER AC WITH N1AH / G2FD										
H1RA036 S(25,46)	N1AHB1246	10,15	21	G2FD036S17	1200	33.8	25.0	10.00	-	9.20
	N1AHB1246	10,15	21	G2FD042S21	1400	40.0	30.1	10.00	-	9.05
H1RA042S(25,46)	N1AHC1646	10,15	21	G2FD042S21	1400	39.5	29.2	10.00	-	9.00
	N1AHC1646	10,15	24	G2FD048S21	1450	41.0	30.3	10.10	-	9.15
H1RA048S(25,46)	N1AHC1646	10,15	21	G2FD048S21	1600	46.0	34.0	10.10	-	9.50
	N1AHD2046	10,15,29	24	G2FD048S24	1600	24.6	34.0	10.10	-	9.50
H1RA060S(25,46)	N1AHD2046	10,15,29	24	G2FD048S24	1600	46.0	34.0	10.10	-	9.50
	N1AHD2046	10,15,29	24	G2FD060S24	1750	58.5	39.8	10.00	-	10.25
1 PH 10 SEER AC / F2RP / RC / FC^{4,5}										
H1RA018S06	F2RC/F2FC024	5,8,10	18	-	650	17.4	12.9	10.00	-	9.00
	F2RP/F2FP018	2,5,8	18	-	650	17.4	12.3	10.00	-	9.00
	F2RP/F2FP024	5,8,10	18	-	650	17.4	12.9	10.00	-	9.00
H1RA024S06	F2RP/F2FP024	5,8,10	18	-	800	23.4	17.3	10.00	-	9.00
	F2RP/F2FP030	5,8,10,15	18	-	800	23.6	17.5	10.00	-	9.10
H2RA030S06	F2RP/F2FP030	5,8,10,15	18	-	1000	28.4	21.0	10.00	-	9.50
	F2RP/F2FP036	5,8,10,15,19	21	-	1000	28.0	20.0	10.00	-	9.00
H2RA036S06	F2RC/F2FC036	5,8,10,15	21	-	1200	33.6	21.5	10.00	-	9.10
	F2RP/F2FP036	5,8,10,15,19	21	-	1200	34.4	25.2	10.20	-	9.30
	F2RP/F2FP042	5,8,10,15	21	-	1200	34.4	25.2	10.15	-	9.20
H1RA042S06	F2RP/F2FP042	5,8,10,15	21	-	1400	39.5	28.9	10.00	-	9.00
	F2FP048	5,8,10,15,20,25	24	-	1400	40.5	30.0	10.00	-	9.20
H1RA048S06	F2FP048	5,8,10,15,20,25	24	-	1600	45.5	33.7	10.00	-	9.15
	F2FP060	5,8,10,15,20,25	24	-	1600	46.5	34.4	10.00	-	9.70
H3RA060S06	F2FP060	5,8,10,15,20,25	24	-	1800	56.0	41.0	10.00	-	9.15
3 PH 10 seer AC with F2RP / FP										
H1RA036 S(25,46)	F2RC/F2FC036	5,8,10,15	21	-	1200	33.6	25.2	10.00	-	9.10
H1RA042S(25,46)	F2RP/F2FP042	5,8,10,15	21	-	1400	39.0	29.2	10.00	-	9.00
	F2FP048	5,8,10,15,20,25	24	-	1400	40.5	30.4	10.00	-	9.00
H1RA048S(25,46)	F2FP048	5,8,10,15,20,25	24	-	1600	45.5	33.7	10.00	-	9.15
H1RA060S(25,46)	F2FP060	5,8,10,15,20,25	24	-	1750	58.5	39.8	10.00	-	9.80
3 PH 10 seer AC WITH K4EV⁶										
H1RA076S25,46	K4EV090	10,16,26,36	22	--	2600	73.5	--	--	--	10.00
H1RA090S25,46	K4EV090	10,16,26,36	22	--	3280	53.8/ 89.0	--	--	--	9.63/ 9.30

Rated in accordance with DOE test procedures (Federal Register 12-27-79 and 3-18-88) and ARI Standards 210/240.

Cooling MBH based on 80°F entering air temperature, 50% RH, and rated air flow.

EER (Energy Efficiency Ratio) is the total cooling output in BTU's at a 95°F outdoor ambient divided by the total electric power in watt-hours at those conditions.

SEER (Seasonal Energy Efficiency Ratio) is the total cooling output in BTU's during a normal annual usage period for cooling divided by the total electric power input in watt-hours during the same period.

1 G2FD coils available with a factory installed horizontal drain pan. See price pages for specific model number.

2 Single phase units require single phase 2HK heaters. Three phase units require three phase 2HK heaters.

3 TXV = Use 1TV700 Series Kit.

4 To meet R=4.2 insulation requirements, substitute F2FP for F2RP, and F2FC for F2RC. models. All ratings remain the same.

5 FG8, FG9, and FL8 furnaces and F2RP / F2RC air handlers have B.O.D (Blower on Delay) standard.

6 H*BA-(T,W)090 is field convertible to two stage operation. Its IPLV = 11.2.

-- = Not Applicable.

COOLING CAPACITY - Upflow, Downflow, & Horizontal Furnaces and Coils

UNIT MODEL	FURNACE**		COIL MODEL	COOLING					
	CFM RANGE (MIN.-MAX.)	W		RATED CFM	NET MBH		SEER + TXV W/O TDR	SEER + TXV ¹ + TDR*	EER
					TOTAL	SENS.			
H1RA018S06	575 725	14,17	G1FA024S14,17	650	18.0	13.3	10.00	-	9.20
		14	G1FA030S14	650	19.0	14.1	10.50	-	9.80
		-	G1HD024	655	18.5	13.7	10.50	-	10.00
		17	G1NA024S17G	650	18.0	12.5	10.00	-	9.40
		14,17	G1UA024S14,17	650	18.0	13.3	10.00	-	9.20
		14	G1UA030S14	650	19.0	14.1	10.50	-	9.80
		14,17	G2FD024S14,17	650	19.0	14.1	10.50	-	9.80
		17	G2FD030S17	650	19.4	14.4	10.50	-	9.90
		14	G2FD035S14	650	19.4	14.4	10.50	-	9.90
H1RA024S06	700 900	14,17	G1FA024S14,17	850	23.8	17.6	10.00	-	9.15
		14	G1FA030S14	800	24.4	18.1	10.50	-	9.55
		14	G1FA036S14	800	24.0	18.1	10.00	-	9.00
		17,21	G1FA036S17,21	850	25.0	18.5	10.00	-	8.95
		-	G1HD024	820	23.2	17.2	10.00	-	8.80
		-	G1HD036	800	24.4	18.1	10.60	-	9.80
		17	G1NA030S17H	800	23.6	17.5	10.00	-	9.00
		21	G1NA030S21B	800	23.6	17.5	10.00	-	9.00
		14,17	G1UA024S14,17	850	23.8	17.6	10.00	-	9.15
		14	G1UA030S14	800	24.4	18.1	10.50	-	9.55
		14	G1UA036S14	800	24.0	18.5	10.00	-	9.00
		17,21	G1UA036S17,21	850	25.0	18.5	10.00	-	8.95
		14,17	G2FD024S14,17	800	24.4	18.5	10.50	-	9.55
		17	G2FD030S17	850	25.0	18.5	10.60	-	9.65
		14	G2FD035S14	850	25.0	18.9	10.60	-	9.65
		17	G2FD036S17	850	25.6	18.9	10.70	-	9.70
H2RA030S06	875 1125	14	G1FA030S14	1000	28.0	20.7	10.00	-	9.30
		14	G1FA036S14	1000	29.2	20.3	10.25	-	9.40
		17,21	G1FA036S17,21	1000	29.0	21.5	10.45	-	9.45
		-	G1HD036	1000	29.6	21.9	10.00	-	9.55
		17	G1NA030S17K	1000	29.0	20.4	10.00	-	9.30
		21	G1NA030S21M	1050	29.0	20.4	10.00	-	9.20
		14	G1UA036S14	1000	29.2	20.3	10.25	-	9.40
		17,21	G1UA036S17,21	1000	29.0	21.5	10.45	-	9.45
		17	G2FD030S17	1000	29.0	21.5	10.30	-	9.45
		14	G2FD035S14	1000	29.0	21.5	10.30	-	9.45
		21	G2FD036S21	1000	30.0	22.2	10.50	-	9.65
H2RA036S06	1050 1350	14	G1FA036S14	1200	33.6	24.9	10.00	-	9.10
		17,21	G1FA036S17,21	1200	33.6	24.9	10.00	-	9.10
		17	G1FA048S17	1200	35.0	25.9	10.30	-	9.40
		21,24	G1FA048S21,24	1200	36.0	26.6	10.40	-	9.40
		-	G1HD036	1200	34.4	25.5	10.00	-	8.90
		-	G1HD048	1165	34.8	25.8	10.00	-	8.95
		17	G1NA036S17J	1200	34.4	25.5	10.00	-	9.20
		21	G1NA036S21C	1200	34.4	25.5	10.00	-	9.30
		14	G1UA036S14	1200	33.6	24.9	10.00	-	9.10
		17,21	G1UA036S17,21	1200	33.6	24.9	10.00	-	9.10
		17	G1UA048S17	1200	35.0	25.9	10.30	-	9.40
		21,24	G1UA048S21,24	1200	36.0	26.6	10.40	-	9.40
		14	G2FD035S14	1200	33.4	24.7	10.00	-	9.10
		17	G2FD036S17	1200	33.8	25.0	10.00	-	9.20
		21	G2FD036S21	1200	33.8	25.0	10.00	-	9.20
		21	G2FD042S21	1200	34.4	25.5	10.15	-	9.30
		17	G2FD046S17	1200	34.4	25.5	10.15	-	9.30

For Notes See Page 5.

COOLING CAPACITY - Upflow, Downflow, & Horizontal Furnaces and Coils (Continued)

UNIT MODEL	FURNACE**		COIL MODEL	COOLING					
	CFM RANGE (MIN.-MAX.)	W		RATED CFM	NET MBH		SEER + TXV W/O TDR	SEER + TXV ¹ + TDR*	EER
					TOTAL	SENS.			
H1RA036S25,46	1050 1350	17,21	G1FA036S17,21	1200	33.6	24.9	10.00	-	9.10
		21,24	G1FA048S21,24	1200	36.0	26.6	10.40	-	9.40
		17	G1NA036S17J	1200	34.4	25.5	10.00	-	9.20
		21	G1NA036S21C	1200	34.4	25.5	10.00	-	9.30
		17,21	G1UA036S17,21	1200	33.6	24.9	10.00	-	9.10
		21,24	G1UA048S21,24	1200	36.0	26.6	10.40	-	9.40
		17	G2FD036S17	1200	33.8	25.0	10.00	-	9.20
H1RA042S06	1225 1575	21	G2FD036S21	1200	33.8	25.0	10.00	-	9.20
		17	G1FA048S17	1380	40.0	30.2	10.00	-	9.05
		21,24	G1FA048S21,24	1400	41.0	30.3	10.00	-	9.25
		21,24	G1FA060S21,24	1400	42.0	31.0	10.00	-	9.45
		-	G1HD048	1390	40.5	30.0	10.00	-	9.05
		21	G1NA036S21C	1400	40.0	28.3	10.00	-	9.15
		21	G1NA048S21D	1400	40.5	28.6	10.00	-	9.15
		17	G1UA048S17	1380	40.0	30.2	10.00	-	9.05
		21,24	G1UA048S21,24	1400	41.0	30.3	10.00	-	9.25
		21,24	G1UA060S21,24	1400	42.0	31.1	10.00	-	9.45
		21	G2FD042S21	1400	39.5	29.2	10.00	-	9.00
		17	G2FD046S17	1380	40.0	29.6	10.00	-	9.05
		21,24	G2FD048S21,24	1450	41.0	30.3	10.10	-	9.15
		24	G2FD060S24	1450	42.0	31.0	10.10	-	9.50
H1RA042S25,46	1225 1575	21,24	G1FA048S21,24	1400	41.0	30.3	10.00	-	9.25
		21,24	G1FA060S21,24	1400	42.0	31.0	10.00	-	9.45
		21	G1NA036S21C	1400	40.0	28.3	10.00	-	9.15
		21	G1NA048S21D	1400	40.5	28.6	10.00	-	9.15
		21,24	G1UA048S21,24	1400	41.0	30.3	10.00	-	9.25
		21,24	G1UA060S21,24	1400	42.0	31.1	10.00	-	9.45
		21	G2FD042S21	1400	39.5	29.2	10.00	-	9.00
		17	G2FD046S17	1380	40.0	29.6	10.00	-	9.05
H1RA048S06	1400 1800	21,24	G2FD048S21,24	1450	41.0	30.3	10.10	-	9.15
		17	G1FA048S17	1500	44.5	33.5	10.00	-	9.15
		21,24	G1FA048S21,24	1600	45.5	33.7	10.00	-	9.45
		21,24	G1FA060S21,24	1600	47.0	34.8	10.40	-	9.70
		-	G1HD048	1600	45.5	33.7	10.00	-	9.50
		-	G1HD060	1600	46.5	34.4	10.20	-	9.65
		21	G1NA048S21D	1400	46.5	34.4	10.00	-	9.50
		17	G1UA048S17	1500	44.5	33.5	10.00	-	9.15
		21,24	G1UA048S21,24	1600	45.5	33.7	10.00	-	9.45
		21,24	G1UA060S21,24	1600	47.0	34.8	10.40	-	9.70
H1RA048S25,46	1400 1800	17	G2FD046S17	1500	44.5	32.9	10.00	-	9.15
		21,24	G2FD048S21,24	1600	46.0	34.0	10.10	-	9.50
		24	G2FD060S24	1600	47.0	34.0	10.40	-	9.70
		21,24	G1FA048S21,24	1600	45.5	33.5	10.00	-	9.45
		21	G1NA048S21D	1400	46.5	34.4	10.00	-	9.50
H3RA060S06	1600 2100	21,24	G1UA048S21,24	1600	45.5	33.5	10.00	-	9.45
		21,24	G1UA060S21,24	1800	56.0	40.2	10.50	-	9.35
		-	G1HD060	2000	55.5	40.0	10.50	-	9.15
		21	G1NA048S21D	1500	51.0	34.8	10.00	-	8.90
		24	G1NA060S24T	1800	55.0	39.8	10.50	-	9.25
		21,24	G1UA060S21,24	1800	56.0	40.2	10.50	-	9.35
		24	G2FD060S24	1800	56.0	40.2	10.50	-	9.35
		24	G2FD061H24	2000	57.0	40.9	10.50	-	9.35
H1RA060S25,46	1525 1975	21,24	G1FA060S21,24	1750	58.5	39.8	10.00	-	10.25
		24	G1NA060S24T	1750	57.5	39.1	10.00	-	10.00
		21,24	G1UA060S21,24	1750	58.5	39.8	10.00	-	10.25
		24	G2FD060S24	1750	58.5	39.8	10.00	-	10.25
H1RA076S25,46	2500-3000	35	G2FD090S35***	3200	73.5	52.9	--	--	10.00
H1RA090S25,46	2500-3000	35	G2FD090S35***	4000	90.0	64.8	--	--	9.35

1 TXV = Use 1TV700 Series Kit.

* Requires a 2FD Blower Time Delay unless a standard furnace is equipped with one.

** Refer to Quick Selection Chart for specific furnace match-up.

*** This coil is for upflow application only.

COOLING PERFORMANCE

MODEL	SUCT. T/P @ COMPR.		AIR TEMP ON CONDENSER						MODEL	SUCT. T/P @ COMPR.		AIR TEMP ON CONDENSER					
			75°F		95°F		115°F					75°F		95°F		115°F	
	TEMP.	PSIG	MBH	KW	MBH	KW	MBH	KW		TEMP.	PSIG	MBH	KW	MBH	KW	MBH	KW
H1RA018S06	35	61.5	16.2	1.66	13.1	1.84	11.0	1.96	H1RA048S06 H1RA048S(25,46)	35	61.5	39.9	4.18	32.3	4.63	27.0	4.94
	40	68.5	17.7	1.67	14.9	1.88	12.8	2.04		40	68.5	43.6	4.21	36.7	4.73	31.4	5.14
	45	76.0	19.3	1.69	16.7	1.92	14.2	2.11		45	76.0	47.6	4.26	41.1	4.84	34.9	5.32
	50	84.0	20.8	1.70	18.5	1.96	15.9	2.18		50	84.0	51.1	4.28	45.5	4.94	39.0	5.48
H1RA024S06	35	61.5	21.0	2.23	17.0	2.46	14.2	2.63	H3RA060S06	35	61.5	49.4	4.15	43.8	5.13	38.2	6.34
	40	68.5	22.9	2.24	19.3	2.52	16.5	2.74		40	68.5	54.0	4.19	48.2	5.14	42.3	6.35
	45	76.0	25.0	2.27	21.6	2.58	18.3	2.83		45	76.0	58.4	4.27	52.4	5.25	46.3	6.47
	50	84.0	26.8	2.28	23.9	2.63	20.5	2.92		50	84.0	62.7	4.32	56.9	5.38	50.2	5.61
H2RA030S06	35	61.5	25.1	2.68	20.3	2.97	17.0	3.17	H1RA060S(25,46)	35	61.5	54.4	4.46	50.5	4.74	46.3	5.08
	40	68.5	27.4	2.70	23.1	3.04	19.7	3.30		40	68.5	60.1	4.44	56.0	4.83	51.6	5.18
	45	76.0	29.9	2.74	25.8	3.10	21.9	3.41		45	76.0	65.8	4.53	61.6	4.92	56.9	5.26
	50	84.0	32.1	2.75	28.6	3.17	24.5	3.51		50	84.0	71.9	4.62	67.5	5.01	62.6	5.36
H2RA036S06 H1RA036 S(25,46)	35	61.5	30.5	3.28	24.7	3.64	20.6	3.88	H1RA076S(25,46)	35	61.5	77.4	5.06	63.4	6.08	50.6	7.35
	40	68.5	33.3	3.31	28.1	3.72	24.0	4.04		40	68.5	84.5	5.21	69.2	6.23	55.4	7.49
	45	76.0	36.4	3.35	31.4	3.80	26.7	4.18		45	76.0	91.8	5.37	75.3	6.38	60.3	7.64
	50	84.0	39.1	3.36	34.8	3.88	29.9	4.31		50	84.0	99.4	5.54	81.7	6.55	65.6	7.80
H1RA042S06 H1RA042S(25,46)	35	61.5	35.8	3.83	28.9	4.25	24.2	4.53	H1RA090S(25,46)	35	61.5	84.0	8.28	72.9	9.11	61.7	9.87
	40	68.5	39.1	3.86	32.9	4.34	28.2	4.72		40	68.5	92.5	8.50	80.8	9.41	68.9	10.26
	45	76.0	42.6	3.90	36.8	4.53	31.3	4.87		45	76.0	101.3	8.73	89.0	9.72	76.5	10.66
	50	84.0	45.8	3.93	40.8	4.63	35.0	5.03		50	84.0	110.4	8.95	97.5	10.03	84.4	11.08

NOTES:

- For condensing unit only. Does not include effect of evaporator motor power or heat.
- Performance based on 15° superheat and 15° sub-cooling at condensing unit.
 - Increase capacity 1% for each 2° increase in sub-cooling.
 - Decrease capacity 1% for each 2° decrease in sub-cooling.
- Sub-cooling in excess of 20° may result in excessively high condensing temperature with air on condenser above 115°F. Maximum recommended condensing temperature is 140°F.

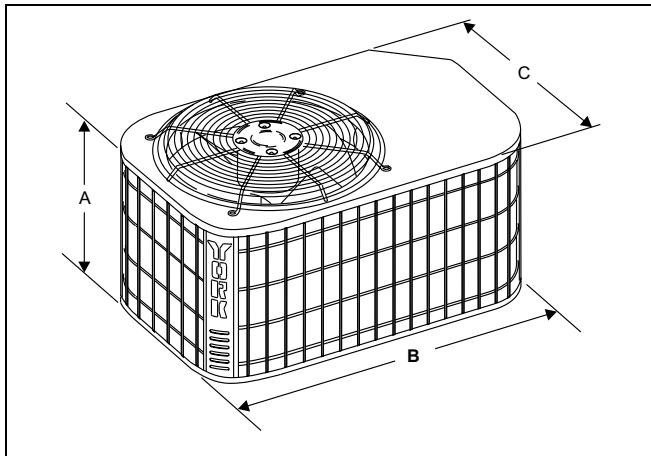

DIMENSIONS - 1 Phase

UNIT MODEL	DIMENSIONS (INCHES)			REFRIGERANT CONNECTION LINE SIZE	
	A ¹	B	C	Liquid	Vapor
018	17	35	23	3/8"	5/8"
024	17	35	23		5/8"
030	19	35	23		3/4"
036	19	35	23		3/4"
042	25	35	23		3/4"
048	27	37	27		7/8"
060	27	37	27		7/8"

DIMENSIONS - 3 Phase

UNIT MODEL	DIMENSIONS (INCHES)			REFRIGERANT CONNECTION LINE SIZE	
	A ¹	B	C	Liquid	Vapor
036	19	35	23	3/8"	3/4"
042	25	35	23	3/8"	3/4"
048	27	37	27	3/8"	7/8"
060	39	37	27	3/8"	7/8"
076	26	43	32	1/2"	1-1/8"
090	32	43	32	1/2"	1-1/8"

¹ Including Fan guard.

ACCESSORIES*

Refer to Price Manual for specific model numbers.

Hard Start Kit - Provides increased starting torque for areas with low voltage.

Compressor Blanket - Designed to further reduce the normal compressor operating sound. Refer to price pages for specific match-ups.

Off Cycle Timer Delay - Provides a 5-minute off cycle to prevent rapid recycling of the compressor.

Room Thermostats - A wide selection of compatible thermostats are available to provide optimum performance and features for any installation.

1 Heat Stage only, manual, mechanical thermostat. Add sub-base for 1H/1C.

1H/1C, manual change-over electronic non-programmable thermostat.

1H/1C, auto/manual changeover, electronic programmable, deluxe 7-day, thermostat.

1H/1C, auto/manual changeover, electronic programmable.

* For the most current accessory information, refer to the price book or consult factory.

SOUND RATINGS*

UNIT MODEL	SOUND RATINGS DECIBELS
018	7.6
024	7.8
030	8.2
036	8.2
042	8.2
048	8.2
060	8.0
076	--
090	9.0

*Rated in accordance with ARI Standard 270.

TYPICAL INSTALLATION

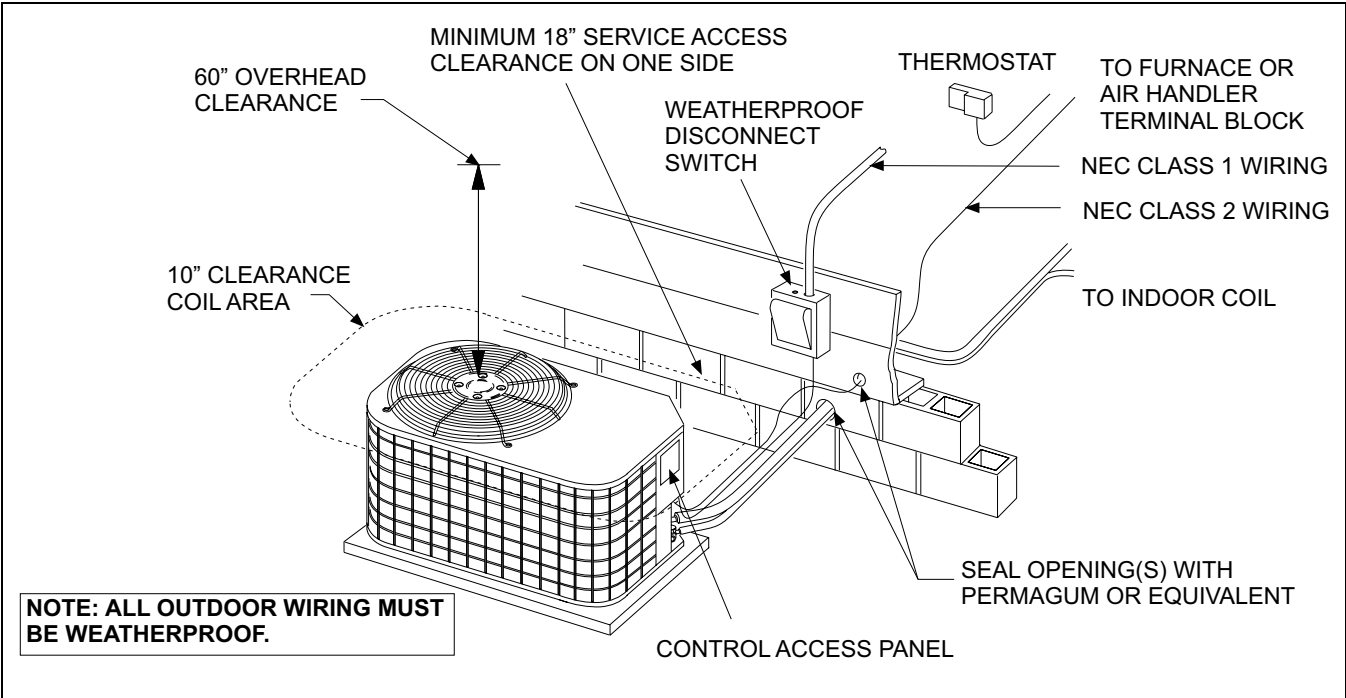

TYPICAL FIELD WIRING - 1 Phase Application

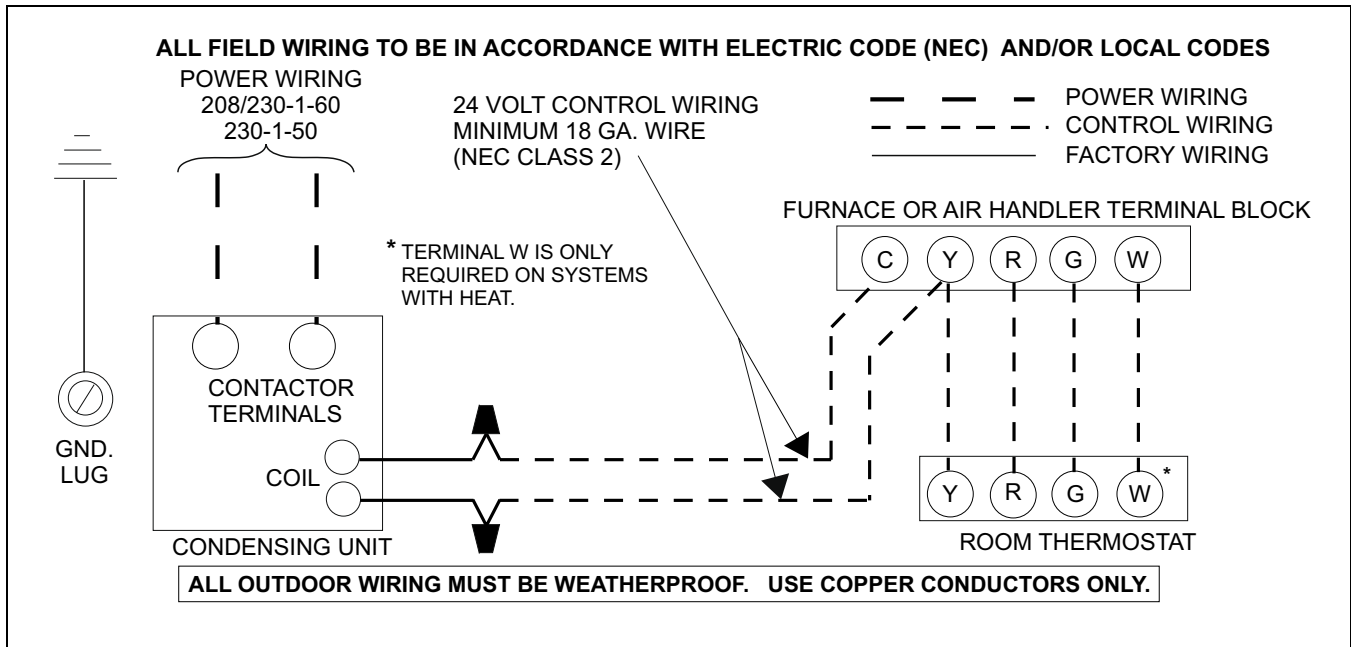

TYPICAL FIELD WIRING - 3 Phase Application

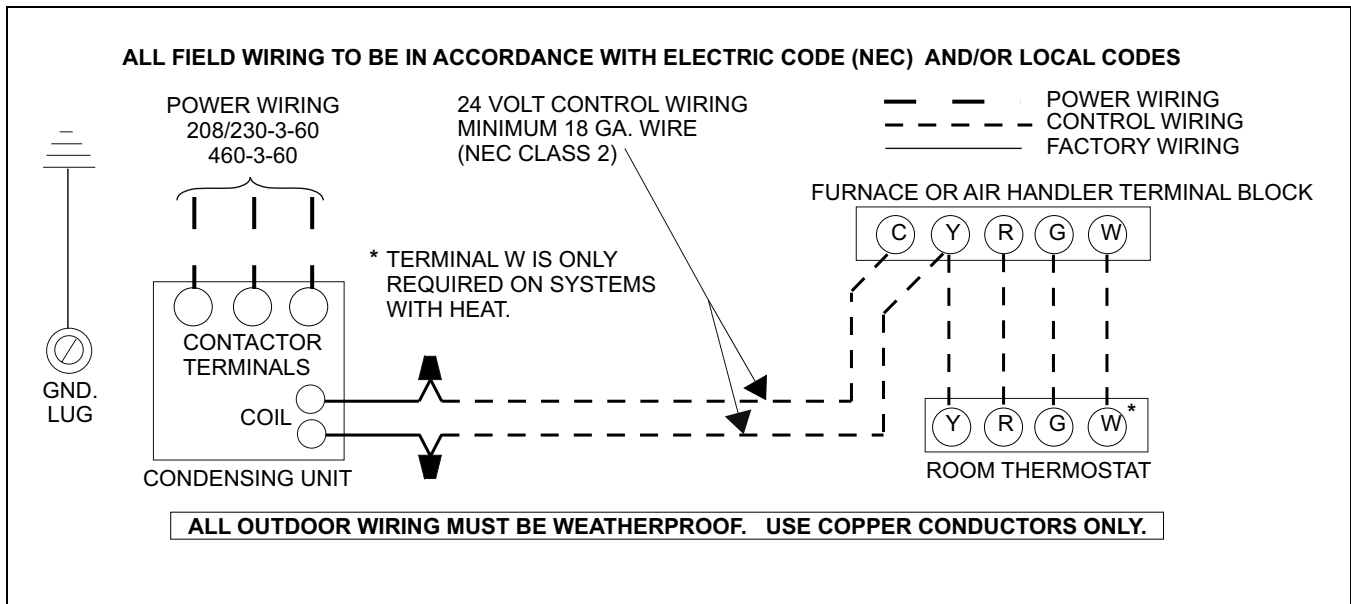

COOLING PERFORMANCE DATA										
AIR CONDITIONER MODEL NO.		H1RA018S06								
INDOOR COIL MODEL NO.		G1FA024S14,17								
CONDENSER ENTERING AIR TEMPERATURE	ID CFM	550			650			750		
	ID DB (°F)	85	80	70	85	80	70	85	80	70
	ID WB (°F)	72	67	57	72	67	57	72	67	57
75	T.C.	20.6	19.7	18.1	20.7	19.8	18.5	20.8	19.8	18.9
	S.C.	12.7	12.8	12.3	13.3	13.5	13.4	13.7	13.8	14.0
	K.W	1.68	1.65	1.64	1.72	1.71	1.70	1.75	1.74	1.73
85	T.C.	20.6	19.3	17.4	20.9	19.6	18.0	21.1	19.8	18.4
	S.C.	12.7	12.6	11.9	13.5	13.4	13.1	14.1	14.0	13.8
	K.W	1.58	1.54	1.53	1.62	1.59	1.58	1.65	1.63	1.62
95	T.C.	19.0	17.5	15.5	19.5	18.0	16.1	19.8	18.2	16.5
	S.C.	12.8	12.4	11.5	13.7	13.3	12.8	14.5	14.1	13.6
	K.W	1.97	1.91	1.90	2.02	1.96	1.95	2.05	2.00	1.99
105	T.C.	18.4	16.6	14.2	18.9	17.1	15.0	19.2	17.4	15.4
	S.C.	12.5	11.8	10.7	13.6	12.8	12.0	14.4	13.7	12.8
	K.W	1.82	1.77	1.75	1.88	1.82	1.80	1.91	1.86	1.83
115	T.C.	16.3	14.5	11.9	16.9	15.0	12.7	17.2	15.2	13.1
	S.C.	12.3	11.2	10.0	13.5	12.4	11.2	14.3	13.2	12.0
	K.W	2.24	2.19	2.14	2.31	2.24	2.19	2.35	2.28	2.22
125	T.C.	14.3	12.3	9.7	14.9	13.0	10.5	15.2	13.1	10.8
	S.C.	12.0	10.6	9.3	13.3	11.9	10.4	14.2	12.8	11.2
	K.W	2.66	2.61	2.53	2.74	2.66	2.58	2.79	2.70	2.61

NOTE: ALL CAPACITIES ARE NET WITH INDOOR FAN HEAT ALREADY DEDUCTED AT 1250 BTUH/1000 CFM

Multipliers for determining the performance with other indoor sections.

Air Handler	Coil	T.C.	S.C.	KW
N1AHB0806	G2FD024S17	1.06	1.06	0.99
F2RC/F2FC024		0.97	0.97	0.99
	G1FA030S14	1.06	1.06	0.99
	G1HD024	1.03	1.03	0.95
	G1NA024S17G	1.00	0.94	0.98
	G1UA024S14,17	1.00	1.00	1.00
	G1UA030S14	1.06	1.06	0.99
	G2FD024S14,17	1.06	1.06	0.99
	G2FD030S17	1.08	1.08	1.00
	G2FD035S14	1.08	1.08	1.00

COOLING PERFORMANCE DATA													
AIR CONDITIONER MODEL NO.		H1RA024S06											
INDOOR COIL MODEL NO.		G1FA024S14, 17											
CONDENSER ENTERING AIR TEMPERATURE	ID CFM	600				800				1000			
	ID DB (°F)	85	80	75	70	85	80	75	70	85	80	75	70
	ID WB (°F)	72	67	62	57	72	67	62	57	72	67	62	57
75	T.C.	28.3	25.9	22.7	21.4	28.7	25.1	24.4	21.8	27.5	26.6	24.5	20.9
	S.C.	16.9	16.9	15.4	17.0	17.7	16.8	17.0	17.8	17.1	18.0	17.3	17.3
	K.W	2.04	1.94	1.78	1.78	2.05	1.87	1.89	1.80	1.97	1.98	1.89	1.72
85	T.C.	28.5	26.0	22.8	21.4	28.9	25.2	24.4	21.8	27.7	26.7	24.6	20.9
	S.C.	17.5	17.5	16.0	17.6	18.5	17.6	17.9	18.7	18.0	19.0	18.2	18.3
	K.W	2.25	2.14	1.95	1.95	2.28	2.06	2.07	1.96	2.18	2.18	2.07	1.88
95	T.C.	26.9	24.5	21.4	20.1	27.3	23.7	23.0	20.6	26.2	25.2	23.0	19.8
	S.C.	17.4	17.4	15.9	17.5	18.5	17.6	17.9	18.8	18.1	19.0	18.3	18.4
	K.W	2.42	2.28	2.06	2.06	2.44	2.20	2.20	2.08	2.34	2.32	2.21	1.99
105	T.C.	24.7	22.4	19.5	18.3	24.8	21.6	20.9	18.6	23.8	22.8	21.1	17.9
	S.C.	16.8	16.8	15.3	16.9	17.9	16.9	17.3	17.9	17.6	18.4	17.6	17.5
	K.W	2.52	2.37	2.15	2.14	2.54	2.30	2.29	2.17	2.43	2.43	2.30	2.07
115	T.C.	22.0	19.9	17.4	16.3	22.2	19.3	18.6	16.9	21.2	20.4	18.8	16.2
	S.C.	15.8	15.7	14.3	15.8	17.0	16.2	16.2	16.7	16.7	17.5	16.8	16.1
	K.W	2.60	2.45	2.23	2.20	2.63	2.36	2.37	2.25	2.51	2.50	2.37	2.17
125	T.C.	19.4	17.5	15.3	14.2	19.5	16.9	16.3	15.1	18.6	17.9	16.5	14.6
	S.C.	14.7	14.7	13.3	14.6	16.0	15.4	15.1	15.4	15.9	16.6	15.9	14.6
	K.W	2.68	2.53	2.31	2.26	2.71	2.43	2.44	2.33	2.59	2.57	2.44	2.27

NOTE: ALL CAPACITIES ARE NET WITH INDOOR FAN HEAT ALREADY DEDUCTED AT 1250 BTUH/1000 CFM.

Multipliers for determining the performance with other indoor sections.

Air Handler	Coil	T.C.	S.C.	KW
N1AHB0806	G2FD024S14,17	0.98	0.98	0.91
N1AHB0806	G2FD030S17	1.00	1.00	0.93
F2RP/F2FP024		0.94	0.94	0.93
F2RP/F2FP030		0.94	0.95	0.93
	G1FA030S14	0.98	0.98	0.91
	G1HD024	0.93	0.93	0.94
	G1HD036	0.98	0.98	0.89
	G1NA030S17H	0.94	0.95	0.94
	G1NA030S21B	0.944	0.946	0.939
	G1UA024S14,17	0.95	0.95	0.93
	G1UA030S14	0.98	0.98	0.91
	G1UA036S17,21	1.00	1.00	1.00
	G2FD024S14,17	0.98	0.98	0.91
	G2FD030S17	1.00	1.00	0.93
	G2FD035S14	1.00	1.00	0.93
	G2FD036S17	1.02	1.02	0.94
	MDD30BSD	0.94	0.95	0.94

COOLING PERFORMANCE DATA													
AIR CONDITIONER MODEL NO.		H2RA030S06											
INDOOR COIL MODEL NO.		G1FA036S17,21											
CONDENSER ENTERING AIR TEMPERATURE	ID CFM	800				1000				1200			
	ID DB (°F)	85	80	75	70	85	80	75	70	85	80	75	70
	ID WB (°F)	72	67	62	57	72	67	62	57	72	67	62	57
75	T.C.	33.9	31.1	28.7	25.6	34.4	31.5	29.1	26.0	34.7	31.8	29.4	26.3
	S.C.	20.5	20.6	19.7	20.7	21.4	21.4	20.6	21.6	22.2	22.2	21.4	22.5
	K.W	2.69	2.64	2.59	2.52	2.78	2.73	2.68	2.61	2.86	2.81	2.76	2.69
85	T.C.	33.0	30.2	27.8	24.9	33.4	30.6	28.2	25.5	33.7	30.9	28.5	25.9
	S.C.	20.6	20.7	19.9	20.9	21.6	21.7	20.9	22.1	22.6	22.6	21.7	23.0
	K.W	2.87	2.79	2.72	2.64	2.94	2.88	2.82	2.75	3.02	2.96	2.90	2.84
95	T.C.	31.3	28.7	26.4	23.7	31.7	29.0	26.7	24.1	31.9	29.2	27.1	24.4
	S.C.	20.3	20.4	19.5	20.8	21.5	21.5	20.7	21.6	22.4	22.5	21.7	22.7
	K.W	3.07	2.98	2.91	2.81	3.15	3.07	3.00	2.92	3.25	3.16	3.10	2.99
105	T.C.	29.3	26.7	24.6	22.0	29.5	27.0	25.0	22.4	29.7	27.2	25.2	23.1
	S.C.	19.9	19.9	19.2	20.0	21.0	21.0	20.1	21.1	22.1	22.1	21.1	22.2
	K.W	3.27	3.17	3.09	2.98	3.37	3.27	3.19	3.07	3.45	3.37	3.28	3.19
115	T.C.	26.9	24.5	22.6	20.3	27.1	24.8	22.9	21.0	27.2	25.1	23.1	21.4
	S.C.	19.2	19.1	18.3	19.1	20.3	20.3	19.3	20.2	21.2	21.2	20.2	20.6
	K.W	3.48	3.37	3.26	3.14	3.57	3.47	3.36	3.26	3.67	3.56	3.46	3.35
125	T.C.	24.5	22.3	20.7	18.6	24.7	22.6	20.9	19.6	24.7	23.0	21.1	19.7
	S.C.	18.5	18.3	17.4	18.2	19.6	19.6	18.4	19.3	20.3	20.3	19.3	19.0
	K.W	3.69	3.57	3.43	3.30	3.77	3.67	3.53	3.45	3.89	3.75	3.64	3.51

NOTE: ALL CAPACITIES ARE NET WITH INDOOR FAN HEAT ALREADY DEDUCTED AT 1250 BTUH/1000 CFM.

Multipliers for determining the performance with other indoor sections.

Air Handler	Coil	T.C.	S.C.	KW
N1AHB1206	G2FD030S17	1.00	1.00	1.00
N1AHB1206	G2FD036S17	1.03	1.03	1.01
F2RP/F2FP030		0.98	0.98	0.97
F2RP/F2FP036		0.97	0.93	1.01
	G1FA030S14	0.97	0.96	0.98
	G1FA036S14	1.01	0.94	1.01
	G1HD036	1.02	1.02	1.01
	G1NA030S17K	1.00	0.95	1.02
	G1NA030S21M	1.00	0.95	1.03
	G1UA036S14	1.01	0.94	1.01
	G1UA036S17,21	1.00	1.00	1.00
	G2FD030S17	1.00	1.00	1.00
	G2FD035S14	1.00	1.00	1.00
	G2FD036S21	1.03	1.03	1.01
	MDD30MSD	1.00	0.95	1.03

COOLING PERFORMANCE DATA										
AIR CONDITIONER MODEL NO.		H2RA036S06, H1RA036S(25,46)								
INDOOR COIL MODEL NO.		G1FA036S17,21								
CONDENSER ENTERING AIR TEMPERATURE	ID CFM	1150			1250			1350		
	ID DB (°F)	85	80	70	85	80	70	85	80	70
	ID WB (°F)	72	67	57	72	67	57	72	67	57
75	T.C.	38.3	36.1	34.4	37.9	36.3	34.6	38.0	36.4	34.9
	S.C.	24.0	23.7	24.0	24.1	24.5	24.7	24.7	25.3	25.2
	K.W	3.19	3.14	3.09	3.23	3.20	3.14	3.26	3.23	3.18
85	T.C.	36.9	34.6	32.2	36.9	34.9	32.6	37.0	35.2	33.0
	S.C.	24.2	23.7	22.9	24.7	24.6	23.9	25.3	25.5	24.8
	K.W	3.45	3.39	3.30	3.50	3.44	3.36	3.53	3.49	3.40
95	T.C.	35.5	33.2	30.0	35.8	33.6	30.4	36.0	34.0	31.0
	S.C.	24.3	23.6	21.9	25.4	24.9	23.6	26.0	25.6	24.4
	K.W	3.71	3.63	3.52	3.76	3.69	3.58	3.80	3.75	3.62
105	T.C.	33.2	30.4	26.7	33.4	30.8	27.2	33.6	31.3	27.7
	S.C.	23.7	22.5	20.7	24.5	23.6	21.9	25.4	24.6	23.0
	K.W	3.97	3.84	3.71	4.02	3.91	3.77	4.06	3.96	3.81
115	T.C.	31.0	27.6	23.5	31.1	28.2	24.2	31.3	28.5	24.4
	S.C.	23.1	21.3	19.6	23.9	22.6	20.7	24.8	23.7	21.6
	K.W	4.22	4.06	3.90	4.29	4.13	3.94	4.33	4.18	4.00
125	T.C.	28.7	24.8	20.2	28.9	25.6	21.1	29.0	25.7	21.0
	S.C.	22.5	20.2	18.4	23.2	21.6	19.6	24.2	22.7	20.2
	K.W	4.47	4.28	4.09	4.56	4.35	4.11	4.60	4.40	4.19

NOTE: ALL CAPACITIES ARE NET WITH INDOOR FAN HEAT ALREADY DEDUCTED AT 1250 BTUH/1000 CFM

Multipliers for determining the performance with other indoor sections.

1 Phase

Air Handler	Coil	T.C.	S.C.	KW
N1AHB1206	G2FD036S17	1.01	1.00	1.00
N1AHB1206	G2FD046S17	1.02	1.02	1.00
F2RC/F2FC036		1.00	0.86	1.00
F2RP/F2FP036		1.02	1.01	1.00
F2RP/F2FP042		1.02	1.01	1.01
	G1FA036S14	1.00	1.00	1.00
	G1FA048S17	1.04	1.04	1.01
	G1FA048S21,24	1.07	1.07	1.04
	G1HD036	1.02	1.02	1.05
	G2FD046S17	1.02	1.02	1.00
	G1HD048	1.04	1.04	1.05
	G1NA036S17J	1.02	1.02	1.01
	G1NA036S21C	1.02	1.02	1.00
	G1UA036S14	1.00	1.00	1.00
	G1UA036S17,21	1.00	1.00	1.00
	G1UA048S17	1.04	1.04	1.01
	G1UA048S21,24	1.07	1.07	1.04
	G2FD035S14	0.99	0.99	0.99
	G2FD036S17	1.01	1.00	1.00
	G2FD036S21	1.01	1.00	1.00
	G2FD042S21	1.02	1.02	1.00
	MDD42CSD	1.02	1.02	1.00

3 Phase

Air Handler	Coil	T.C.	S.C.	KW
N1AHB1246	G2FD036S17	1.00	1.00	0.98
N1AHB1246	G2FD046S21	1.02	1.02	1.00
F2RC/F2FC036		1.00	0.86	1.00
	G1FA048S21,24	1.07	1.07	1.04
	G1NA036S17J	1.02	1.02	1.01
	G1NA036S21C	1.02	1.02	1.00
	G1UA036S17,21	1.00	1.00	1.00
	G1UA048S21,24	1.07	1.07	1.04
	G2FD036S17	1.01	1.00	1.00
	G2FD036S21	1.01	1.00	1.00

COOLING PERFORMANCE DATA										
AIR CONDITIONER MODEL NO.		H1RA042S06, H1RA042S(25,46)								
INDOOR COIL MODEL NO.		G1FA048S21,24								
CONDENSER ENTERING AIR TEMPERATURE	ID CFM	1200			1400			1600		
	ID DB (°F)	85	80	70	85	80	70	85	80	70
	ID WB (°F)	72	67	57	72	67	57	72	67	57
75	T.C.	47.2	44.1	41.2	47.5	44.6	41.9	47.9	45.1	42.6
	S.C.	30.2	29.6	29.4	31.9	31.1	31.0	33.6	32.6	32.6
	K.W	3.90	3.85	3.78	4.05	3.99	3.94	4.19	4.14	4.09
85	T.C.	45.5	42.1	38.5	45.9	42.8	39.3	46.3	43.4	40.2
	S.C.	29.8	28.9	28.1	31.4	30.7	30.0	33.0	32.5	31.9
	K.W	4.13	4.06	3.96	4.28	4.21	4.13	4.43	4.36	4.29
95	T.C.	43.9	40.2	35.7	44.3	41.0	36.8	44.8	41.8	37.8
	S.C.	29.5	28.2	26.9	30.9	30.3	29.1	32.4	32.4	31.2
	K.W	4.36	4.27	4.14	4.52	4.43	4.31	4.67	4.59	4.49
105	T.C.	40.5	36.3	32.0	41.2	37.1	32.8	42.0	38.0	33.7
	S.C.	28.1	26.7	25.1	29.9	28.8	27.2	31.7	30.9	29.3
	K.W	4.58	4.44	4.30	4.74	4.60	4.47	4.89	4.77	4.64
115	T.C.	37.1	32.3	28.3	38.2	33.3	28.9	39.2	34.2	29.6
	S.C.	26.8	25.1	23.3	29.0	27.2	25.4	31.1	29.4	27.4
	K.W	4.81	4.62	4.45	4.96	4.78	4.62	5.10	4.95	4.79
125	T.C.	33.7	28.4	24.5	35.1	29.4	25.0	36.4	30.4	25.4
	S.C.	25.5	23.5	21.5	28.0	25.7	23.5	30.5	27.9	25.5
	K.W	5.04	4.79	4.61	5.18	4.96	4.78	5.32	5.13	4.94

NOTE: ALL CAPACITIES ARE NET WITH INDOOR FAN HEAT ALREADY DEDUCTED AT 1250 BTUH/1000 CFM.

Multipliers for determining the performance with other indoor sections.

1 Phase

Air Handler	Coil	T.C.	S.C.	KW
N1AHC1606	G2FD042S21	0.96	0.96	0.99
N1AHC1606	G2FD048S21	1.00	1.00	1.01
F2RP/F2FP042		0.96	0.95	0.99
F2FP048		0.99	0.99	0.99
	G1FA048S17	0.98	1.00	1.00
	G1FA060S21,24	1.02	1.02	1.00
	G1HD048	0.99	0.99	1.01
	G1NA036S21C	0.98	0.93	0.99
	G1NA048S21D	0.99	0.94	1.00
	G1UA048S17	0.98	1.00	1.00
	G1UA048S21,24	1.00	1.00	1.00
	G1UA060S21,24	1.02	1.03	1.00
	G2FD042S21	0.96	0.96	0.99
	G2FD046S17	0.98	0.98	1.00
	G2FD048S21,24	1.00	1.00	1.01
	G2FD060S24	1.02	1.02	1.00
	MDD48DSD	0.99	0.94	1.00

3 Phase

Air Handler	Coil	T.C.	S.C.	KW
N1AHC1646	G2FD042S21	0.98	0.99	1.00
N1AHC1646	G2FD048S21	0.99	1.01	1.01
F2RP/F2FP042		0.95	0.95	0.99
F2FP048		0.99	0.99	0.99
	G1FA060S21,24	1.02	1.02	1.00
	G1NA036S21C	0.98	0.93	0.99
	G1NA048S21D	0.99	0.94	1.00
	G1UA048S21,24	1.00	1.00	1.00
	G1UA060S21,24	1.02	1.03	1.00
	G2FD042S21	0.96	0.96	0.99
	G2FD046S17	0.98	0.98	1.00
	G2FD048S21,24	1.00	1.00	1.01

COOLING PERFORMANCE DATA													
AIR CONDITIONER MODEL NO.		H1RA048S06, H1RA048S(25,46)											
INDOOR COIL MODEL NO.		G1FA048S21,24											
CONDENSER ENTERING AIR TEMPERATURE	ID CFM	1200				1400				1600			
	ID DB (°F)	85	80	75	70	85	80	75	70	85	80	75	70
	ID WB (°F)	72	67	62	57	72	67	62	57	72	67	62	57
75	T.C.	53.4	48.9	45.1	40.2	54.3	49.8	45.9	41.3	54.9	50.3	46.4	41.8
	S.C.	32.2	32.3	31.0	32.5	34.0	34.0	32.7	34.7	35.2	35.3	33.9	35.9
	K.W	4.32	4.15	4.00	3.83	4.44	4.26	4.11	3.95	4.53	4.36	4.21	4.04
85	T.C.	52.0	47.5	43.7	39.2	52.7	48.3	44.5	40.0	53.2	48.7	45.2	40.5
	S.C.	32.2	32.3	31.1	32.7	34.1	34.1	32.8	34.7	35.4	35.5	34.5	36.0
	K.W	4.62	4.43	4.26	4.07	4.74	4.55	4.38	4.18	4.84	4.65	4.48	4.28
95	T.C.	49.0	44.9	41.3	36.9	49.6	45.5	42.0	37.6	50.0	45.8	42.4	38.3
	S.C.	31.6	31.6	30.4	31.8	33.5	33.7	32.4	33.8	34.9	35.0	33.7	35.6
	K.W	4.91	4.70	4.51	4.31	5.02	4.81	4.64	4.43	5.13	4.92	4.74	4.53
105	T.C.	45.6	41.6	38.4	34.3	46.0	42.2	39.0	35.0	46.2	42.5	39.3	36.2
	S.C.	30.5	30.6	29.5	30.9	32.6	32.8	31.5	32.8	34.1	34.2	32.7	34.5
	K.W	5.18	4.96	4.76	4.54	5.30	5.07	4.88	4.67	5.39	5.18	4.99	4.83
115	T.C.	41.8	38.3	35.3	31.7	42.3	38.8	35.8	33.0	42.5	39.0	36.2	33.5
	S.C.	29.3	29.5	28.2	29.6	31.6	31.4	30.1	31.5	33.0	32.9	31.5	32.0
	K.W	5.42	5.18	4.98	4.76	5.52	5.31	5.10	4.94	5.63	5.41	5.21	5.06
125	T.C.	38.0	35.0	32.3	29.1	38.6	35.4	32.7	31.0	38.8	35.5	33.2	30.8
	S.C.	28.1	28.4	26.9	28.3	30.6	30.0	28.7	30.2	31.9	31.6	30.4	29.5
	K.W	5.66	5.40	5.20	4.98	5.74	5.55	5.32	5.21	5.87	5.64	5.43	5.29

NOTE: ALL CAPACITIES ARE NET WITH INDOOR FAN HEAT ALREADY DEDUCTED AT 1250 BTUH/1000 CFM.

Multipliers for determining the performance with other indoor sections.

1 Phase

Air Handler	Coil	T.C.	S.C.	KW
N1AHC1606	G2FD048S21	1.01	1.01	1.01
N1AHD2006	G2FD060S24	1.03	1.03	1.01
F2FP048		1.00	1.00	1.03
F2FP060		1.02	1.02	1.00
	G1FA048S17	0.98	0.99	1.01
	G1FA060S21,24	1.03	1.03	1.01
	G1HD048	1.00	1.00	0.99
	G1HD060	1.02	1.02	1.00

3 Phase

Air Handler	Coil	T.C.	S.C.	KW
N1AHC1646	G2FD048S21	1.01	1.01	1.00
N1AHD2046	G2FD048S24	1.01	1.01	1.00
N1AHD2046	G2FD060S24	1.03	1.03	1.00
F2FP048		1.00	1.00	1.03
	G1FA048S21,24	1.00	1.00	1.00
	G1NA048S21D	1.02	1.02	1.02
	G1UA048S21,24	1.00	1.00	1.00
	G2FD048S21,24	1.01	1.01	1.01

COOLING PERFORMANCE DATA										
AIR CONDITIONER MODEL NO.		H3RA060S06								
INDOOR COIL MODEL NO.		G1FA060S21,24								
CONDENSER ENTERING AIR TEMPERATURE	ID CFM	2050			1800			1550		
	ID DB (°F)	85	80	70	85	80	70	85	80	70
	ID WB (°F)	72	67	57	72	67	57	72	67	57
75	T.C.	64.7	61.9	58.2	64.1	61.2	57.2	63.6	60.5	56.2
	S.C.	46.3	44.9	42.9	43.3	42.1	40.3	40.3	39.3	37.7
	K.W	5.18	5.13	5.03	5.08	5.02	4.92	4.97	4.91	4.81
85	T.C.	62.8	59.6	55.4	62.3	58.6	54.3	61.8	57.6	53.3
	S.C.	45.9	44.3	41.9	42.8	41.2	39.2	39.7	38.2	36.5
	K.W	4.94	4.86	4.77	5.58	5.50	5.40	5.48	5.40	5.28
95	T.C.	60.9	57.3	52.7	60.4	56.0	51.5	59.9	54.7	50.3
	S.C.	45.7	43.5	40.8	42.4	40.2	38.0	39.2	37.0	35.2
	K.W	6.19	6.10	6.00	6.09	5.99	5.87	5.98	5.88	5.74
105	T.C.	57.2	53.4	48.4	56.6	52.3	47.4	56.0	51.1	46.4
	S.C.	44.6	42.1	39.3	41.3	39.0	36.6	38.0	35.9	33.8
	K.W	6.82	6.70	6.56	6.71	6.59	6.44	6.60	6.47	6.31
115	T.C.	53.5	49.5	44.1	52.8	48.5	43.3	52.1	47.5	42.4
	S.C.	43.6	40.5	37.7	40.2	37.6	35.1	36.8	34.7	32.4
	K.W	7.47	7.32	7.14	7.35	7.19	7.01	7.22	7.06	6.88
125	T.C.	49.8	45.6	39.9	49.0	44.8	39.2	48.2	43.9	38.5
	S.C.	42.5	39.0	36.1	39.0	36.3	33.6	35.6	33.6	31.0
	K.W	8.12	7.94	7.72	7.99	7.79	7.58	7.84	7.65	7.45

NOTE: ALL CAPACITIES ARE NET WITH INDOOR FAN HEAT ALREADY DEDUCTED AT 1250 BTUH/1000 CFM.

Multipliers for determining the performance with other indoor sections.

Air Handler	Coil	T.C.	S.C.	KW
N1AHD2006	G2FD060S24	1.00	1.00	1.00
F2FP060		1.00	1.02	1.02
	G1HD060	0.99	1.00	1.01
	G1NA048S21D	0.91	0.87	0.96
	G1NA060S24T	0.98	0.99	0.99
	G1UA060S21,24	1.00	1.00	1.00
	G2FD060S24	1.00	1.00	1.00
	G2FD061H24	1.02	1.02	1.02

COOLING PERFORMANCE DATA										
AIR CONDITIONER MODEL NO.		H1RA060S(25,46)								
INDOOR COIL MODEL NO.		G2FD060S24A								
CONDENSER ENTERING AIR TEMPERATURE	ID CFM	1450			1700			1950		
	ID DB (°F)	85	80	70	85	80	70	85	80	70
	ID WB (°F)	72	67	57	72	67	57	72	67	57
75	T.C.	61.2	58.5	56.3	61.8	59.1	56.9	62.3	59.6	57.5
	S.C.	37.6	37.4	37.1	40.1	39.9	39.5	42.5	42.3	41.8
	K.W	4.66	4.57	4.51	4.67	4.58	4.53	4.68	4.58	4.55
85	T.C.	60.6	58.0	55.0	61.2	58.6	55.8	61.9	59.3	56.7
	S.C.	37.6	37.3	36.5	40.2	39.9	39.1	42.8	42.5	41.7
	K.W	5.26	5.13	5.08	5.27	5.14	5.10	5.28	5.15	5.11
95	T.C.	60.0	57.4	53.7	60.7	58.5	54.8	61.4	59.0	55.8
	S.C.	37.5	37.1	35.9	40.3	39.8	38.8	43.1	42.6	41.6
	K.W	5.86	5.70	5.65	5.87	5.71	5.67	5.88	5.72	5.68
105	T.C.	58.1	54.6	50.0	58.9	55.7	51.3	59.7	56.8	52.7
	S.C.	36.9	36.0	34.4	39.8	39.0	37.3	42.7	41.9	40.2
	K.W	6.54	6.39	6.29	6.56	6.42	6.30	6.57	6.45	6.32
115	T.C.	56.2	51.8	46.3	57.1	53.2	47.9	57.9	54.5	49.5
	S.C.	36.2	34.9	32.9	39.3	38.1	35.9	42.3	41.2	38.8
	K.W	7.23	7.07	6.92	7.25	7.12	6.94	7.26	7.17	6.97
125	T.C.	54.3	49.0	42.6	55.2	50.6	44.5	56.2	52.3	46.4
	S.C.	35.6	33.8	31.4	38.7	37.2	34.4	41.9	40.5	37.4
	K.W	7.92	7.76	7.55	7.94	7.83	7.58	7.96	7.90	7.62

Multipliers for determining the performance with other indoor sections.

Air Handler	Coil	T.C.	S.C.	KW
N1AHD2046	G2FD060S24	1.00	1.00	1.00
F2FP060		1.00	1.00	1.05
	G1FA060S21,24	1.00	1.00	1.00
	G1NA060S24T	0.98	0.98	1.01
	G1UA060S21,24	1.00	1.00	1.00

COOLING PERFORMANCE DATA										
AIR CONDITIONER MODEL NO.		H1RA076S(25,46)								
INDOOR COIL MODEL NO.		K4EV090								
CONDENSER ENTERING AIR TEMPERATURE	ID CFM	2100			2600			3100		
	ID DB (°F)	85	80	70	85	80	70	85	80	70
	ID WB (°F)	72	67	57	72	67	57	72	67	57
		T.C.	S.C.	K.W	T.C.	S.C.	K.W	T.C.	S.C.	K.W
75	T.C.	79.1	76.3	73.9	82.0	79.2	76.9	84.9	82.0	79.9
	S.C.	48.8	48.6	48.1	55.4	55.3	54.7	62.0	61.9	61.3
	K.W	5.98	5.90	5.84	6.28	6.18	6.15	6.58	6.48	6.46
85	T.C.	76.4	73.7	70.6	79.1	76.3	73.4	81.7	79.0	76.2
	S.C.	47.9	47.6	46.8	54.7	54.4	53.5	61.5	61.2	60.3
	K.W	6.53	6.42	6.37	6.86	6.74	6.70	7.18	7.07	7.04
95	T.C.	73.8	71.1	67.2	76.1	73.5	69.9	78.4	75.9	72.6
	S.C.	47.1	46.7	45.4	54.0	53.6	52.4	60.9	60.4	59.4
	K.W	7.08	6.94	6.90	7.43	7.30	7.26	7.79	7.65	7.61
105	T.C.	71.1	67.4	62.6	73.1	69.7	65.2	75.1	72.0	67.7
	S.C.	46.4	45.4	43.7	53.1	52.2	50.5	59.8	58.9	57.2
	K.W	7.84	7.70	7.61	8.21	8.08	7.99	8.57	8.46	8.36
115	T.C.	68.4	63.7	58.0	70.0	67.0	60.4	71.7	68.2	62.9
	S.C.	45.4	44.1	42.0	52.0	51.9	48.5	58.6	57.5	55.0
	K.W	8.59	8.46	8.32	8.97	8.80	8.71	9.36	9.28	9.10
125	T.C.	65.6	60.1	53.4	67.0	64.3	55.7	68.4	64.3	58.1
	S.C.	44.5	42.7	40.2	51.0	51.6	46.5	57.5	56.0	52.8
	K.W	9.35	9.21	9.02	9.74	9.51	9.43	10.14	10.09	9.84

NOTE: ALL CAPACITIES ARE NET WITH INDOOR FAN HEAT ALREADY DEDUCTED AT 1250 BTUH/1000 CFM.

Multipliers for determining the performance with other indoor sections.

Coil	T.C.	S.C.	KW
G2FD090S35	1.00	0.99	1.01

COOLING PERFORMANCE DATA										
AIR CONDITIONER MODEL NO.		H1RA090S(25,46)								
INDOOR COIL MODEL NO.		K4EV090								
CONDENSER ENTERING AIR TEMPERATURE	ID CFM	2400			3000			3600		
	ID DB (°F)	85	80	70	85	80	70	85	80	70
	ID WB (°F)	72	67	57	72	67	57	72	67	57
75	T.C.	104.2	97.2	90.1	108.1	100.5	92.8	112.1	103.8	95.5
	S.C.	76.5	71.0	65.6	78.7	72.8	66.9	81.0	74.6	68.2
	K.W	8.30	8.21	8.13	8.33	8.25	8.18	8.36	8.29	8.23
85	T.C.	99.1	92.4	85.8	102.0	94.7	87.5	104.8	97.0	89.1
	S.C.	72.5	67.4	62.3	74.0	68.4	62.8	75.5	69.4	63.4
	K.W	8.97	8.86	8.75	9.01	8.90	8.79	9.04	8.94	8.84
95	T.C.	94.0	87.7	81.5	95.8	89.0	82.1	97.5	90.1	82.7
	S.C.	68.6	63.8	59.0	69.3	64.0	58.7	70.0	64.2	58.5
	K.W	9.64	9.50	9.37	9.68	9.55	9.41	9.72	9.59	9.45
105	T.C.	88.2	82.2	76.1	89.8	83.9	77.9	91.4	85.6	79.7
	S.C.	68.7	63.7	58.7	69.2	64.3	59.4	69.8	64.9	60.1
	K.W	10.33	10.14	9.96	10.38	10.21	10.03	10.43	10.27	10.10
115	T.C.	82.5	76.6	70.8	83.9	78.8	73.8	85.3	81.0	76.7
	S.C.	59.9	55.4	50.9	60.2	56.3	52.4	60.5	57.2	53.9
	K.W	11.02	10.79	10.55	11.08	10.87	10.65	11.14	10.95	10.76
125	T.C.	76.7	71.1	65.5	78.0	73.8	69.6	79.2	76.5	73.7
	S.C.	55.5	51.2	46.8	55.7	52.4	49.2	55.8	53.7	51.6
	K.W	11.71	11.43	11.15	11.78	11.53	11.28	11.86	11.63	11.41

NOTE: ALL CAPACITIES ARE NET WITH INDOOR FAN HEAT ALREADY DEDUCTED AT 1250 BTUH/1000 CFM.

Multipliers for determining the performance with other indoor sections.

Coil	T.C.	S.C.	KW
G2FD090S35	1.01	1.01	1.01

MATCHING INDOOR COMPONENTS

ADD-ON COILS - FOR FURNACE APPLICATIONS

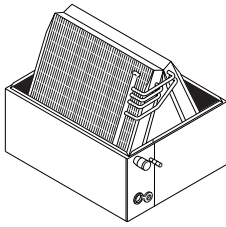

G1UA
1/2 CASED
UPFLOW

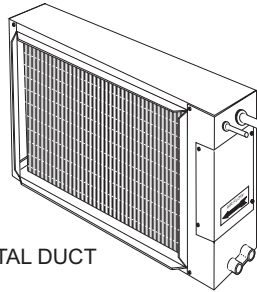

G1HD
HORIZONTAL DUCT

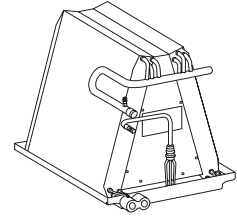

G1NA
UNCASED
UPFLOW

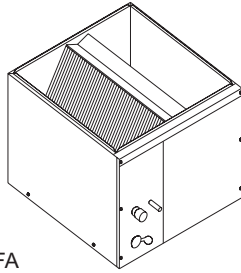

G1FA
FULL CASED
UPFLOW

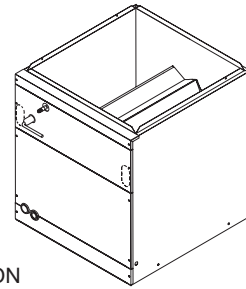

G2FD*
MULTI-POSITION
(UPFLOW, HORIZONTAL
AND DOWNFLOW)

G2FD090 is upflow only.

* Available with factory installed horizontal drain pan.

AIR HANDLERS - FOR NON-FURNACE APPLICATIONS

N1AH OR N1VS
MODULAR BLOWER
(UPFLOW, HORIZONTAL
AND DOWNFLOW)

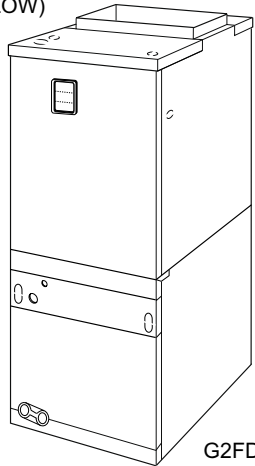

G2FD
COIL

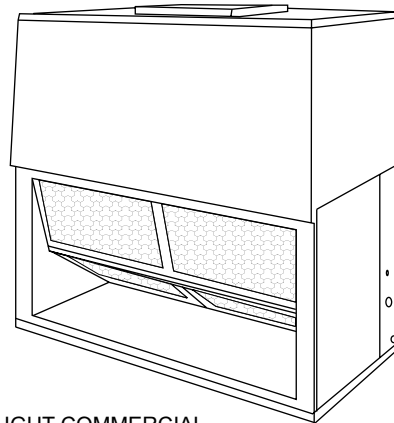

LIGHT COMMERCIAL
APPLICATIONS

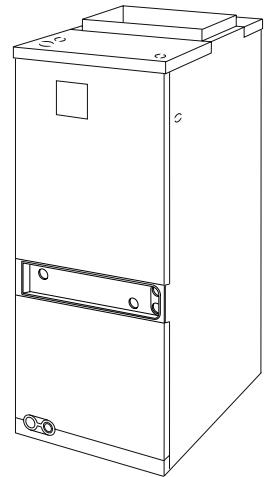

F2RC / F2FC OR
F2RC / F2FP
FAN COIL UNITS
(UPFLOW, HORIZONTAL)

NOTES

Unitary	5005	Norman
Products	York	OK
Group	Drive	73069