

Clean Air Gun™ Series

400, 600 Amp MIG Guns

Issued Jan. 2008 • SPEC CA-1.5

400 Amp Clean Air Gun™



Bernard Clean Air Guns™ help create an efficient shop with reduced smoke and fumes regardless of your operation.

All Guns are Not Created Equal.

A MIG gun should be durable, easy to use and customized to your specific application. Our MIG guns put you in control: you choose the options you need and we'll build a gun to last.

Heavy-duty handles for durability.

45 degree bend for maximum feeding characteristics.

Chrome parts to resist spatter adhesion.

Adjustable vacuum chamber maximizes suction without affecting shielding gas and provides for efficient smoke collection.

Ideally suited for almost any heavy-duty MIG welding application.

Compatible with Centerfire™ series consumables for better arc starts, less spatter, more consistent welds and longer tip life.

	PART NO.	CABLE LENGTH	STD. LINER	WIRE SIZE	STD. TIP	STD. NOZZLE	STD. GAS DIFFUSER
400 Amp	CA410A-B	10' (3.05 m)	44115	.035" - .045"	7490	4492	4435
	CA415A-B	15' (4.57 m)		(0.9 mm - 1.2 mm)			
	CA410B-B	10' (3.05 m)	44215	1/16"	7491	4591	4435
	CA415B-B	15' (4.57 m)		(1.6 mm)			
600 Amp	CA610A-B	10' (3.05 m)	44115	.035" - .045"	7490	4492	4435
	CA615A-B	15' (4.54 m)		(0.9 mm - 1.2 mm)			
	CA610B-B	10' (3.05 m)	44215	1/6"	1591	4591	4635
	CA615B-B	15' (4.57 m)		(1.6 mm)			
	CA610C-B	10' (3.05 m)	45415	3/32"	1593	4591	4635
	CA615C-B	15' (4.57 m)		(2.4 mm)			

Note: Bernard Clean Air Guns™ are only available with Bernard Quick Disconnect direct plug. A minimum of 70 CFM @ 35" H₂O of air flow is required for efficient operation.

Made with
Pride and without
Compromise in the **USA**

Bernard®

An Illinois Tool Works Company
449 West Corning Road, Box 667
Beecher, Illinois 60401 USA

Phone: 800-946-2281 (US Only) 708-946-2281 (Outside US)
Fax: 708-946-6726
For more information, visit us at BernardWelds.com



Replacement Parts List

AIR COOLED GUN COMPONENTS		400 Amp	600 Amp
1	Vacuum Chamber	1390006	1390008
2	Nozzle w/Insulator	See Nozzle Chart (below)	
3	Contact Tip	See Tip Chart (below)	
4	Gas Diffuser	See Diffuser Chart (below)	
5	Spacer	2460016	2460015
6	Vacuum Tube (Smoke Shroud)	2390002	2390001
7	Body Tube	1040049	1040049
8	Handle Kit	1880037	1880037
8A	Post Fastener	4207	4207
8B	Screw	4209	4209
8C	Trigger Screw	418	418
9	Trigger Assembly	422	422

AIR COOLED GUN CABLE COMPONENTS		See Cable Saver Chart (below)	
10	Cable Saver, 3'	See Cable Saver Chart (below)	
11	Vacuum Hose Kit 10'	1880046	1880046
	Vacuum Hose Kit 12'	1880047	1880047
	Vacuum Hose Kit 15'	1880048	1880048
11A	Clamp, Headless	1520011	1520011
11B	Swivel Kit	1880036	1880036
11C	Vacuum Hose, 10'	1800013	1800013
	Vacuum Hose, 12'	1880014	1880014
	Vacuum Hose, 15'	1880015	1880015
12	Power Cable Assy, 10'	1880054	1880040
	Power Cable Assy, 12'	1880055	1880041
	Power Cable Assy, 15'	1880056	1880042
12A	Shrink Tube	9096	9096
12B	Lead Set	1130016	1130016
12B1	Flag Terminal	457	457
12B2	Butt Connector	4932	4932

AIR COOLED GUN DISCONNECT COMPONENTS			
13A	Strain Relief	2520076	2520076
13B	Clamp	1520011	1520011
14A	Power Pin	2200008	2200008
14B	O-Ring (2 Required)	4929	4929
14C	Lead Wire (2 Required)	4924	4924
14D	Gas Pin Assembly	2060033	2060033
14E	Snap Ring, Large	4911	4911
14F	Wave Ring	4916	4916
14G	Snap Ring, Medium	4912	4912
14H	Snap Ring, Small	2250016	2250016
14I	Locking Sleeve	4925	4925
15	Liner	See Liner Chart (below)	

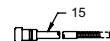
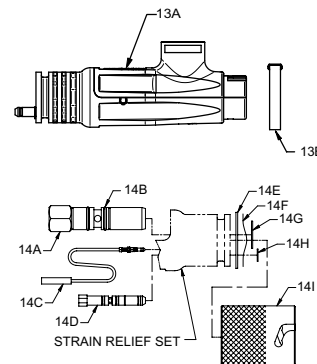
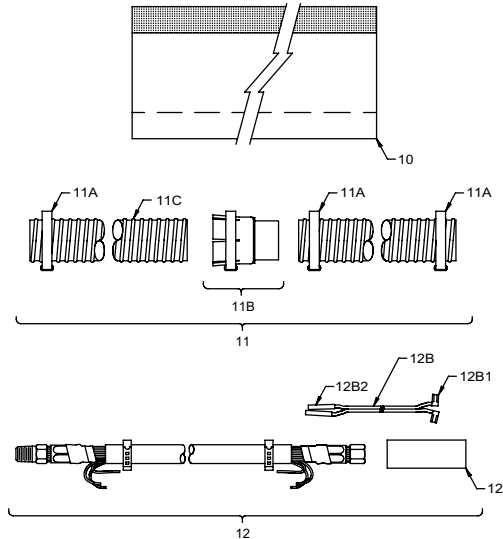
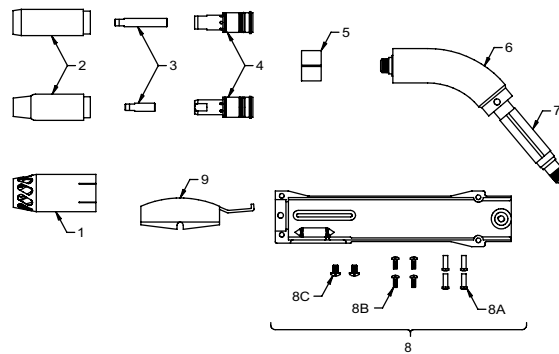

Nozzles, Insulators, Assembled (Item #2)	Elliptical Tips (Item #3)	Heavy Duty		Standard		Liners (Item #16)	
		Use w/4635 Head	Use w/4435 Head	Use w/4435 Head	Use w/4435 Head		
1/2" Copper	.023 (.6mm)	1597		7497		3/64", 15' Aluminum	43115X
3/4" Brass	.030 (.8mm)	1588		7488		.035 - .045, 15'	44115
1/2" Brass	.035 (.9mm)	1589		7489		1/16", 15'	44215
3/4" Copper	.039 (1.0mm)	1596		7496		5/64", 15'	44315
	.045 (1.2mm)	1590		7490		3/32", 15'	45415
	.052 (1.4mm)	1598		7498		7/64", 15'	45615
	1/16" (1.6mm)	1591		7491		1/8", 15'	46715
	5/64" (2.0mm)	1592		7492			
	3/32" (2.4mm)	1593		7493			
	7/64" (2.8mm)	1594		7494			
	1/8" (3.2mm)	1595		7495			
Gas Diffusers (Item #4)						Cable Cover (Item #10)	
7400 Series Tips	4435					9' Leather w/Velcro	1860005
1500 Series Tips	4635					13' Leather w/Velcro	1860008