



2010© Koninklijke Philips Electronics N.V. All rights reserved.  
Philips and the Philips Shield Emblem are registered trade marks  
of Koninklijke Philips Electronics N.V and are used under license  
from Koninklijke Philips Electronics N.V.

**BDL3215E**  
**BDL4225E**

**PHILIPS**



# TABLE OF CONTENTS

SAFETY INSTRUCTIONS.....	1
Contents.....	7
Elements Name and Functions .....	8
Control Panel .....	8
Terminal Panel.....	9
Remote Control.....	10
Operating Range for the Remote Control .....	11
Handling the remote control .....	11
How to mount or attach table stand to the LCD Monitor .....	12
Setup Procedure.....	14
Install the LCD Monitor in Portrait Mode.....	16
Connectivity .....	17
Connectivity Diagram .....	17
Connecting to a Personal Computer .....	18
Connecting to a Digital Interface Equipment .....	19
Connecting to a DVD Player.....	20
Connecting to a Stereo Amplifier.....	21
Basic Operation.....	22
Power ON and OFF Modes.....	22
Power Indicator.....	23
Using Power Management.....	23
Display Signal of Video Source Setting to [VIDEO].....	23
Picture Size.....	23
Smart Picture Mode.....	24
Audio Source Switching.....	24
Control Lock Mode .....	24
OSD Information .....	24
OSD (On-Screen-Display) Controls .....	25
PICTURE.....	26
SCREEN .....	28
AUDIO.....	30
PIP (PICTURE IN PICTURE).....	31
CONFIGURATION 1 .....	32
CONFIGURATION 2 .....	34
ADVANCED OPTION.....	36
NOTE.....	39
Pixel defect policy .....	41
Features that do not require user interface .....	42
Troubleshooting .....	43
Specifications.....	45
Pin Assignment.....	49

# SAFETY INSTRUCTIONS

## WARNINGS AND PRECAUTIONS

### KNOW THESE SAFETY SYMBOLS



**CAUTION:** TO REDUCE THE RISK OF ELECTRIC SHOCK, DO NOT REMOVE COVER (OR BACK). NO USER SERVICEABLE PARTS INSIDE. REFER SERVICING TO QUALIFIED SERVICE PERSONNEL.



This symbol indicates high voltage is present inside. It is dangerous to make any kind of contact with any inside part of this product.



This symbol alerts you that important literature concerning operation and maintenance has been included with this product.

**Note to CATV system installer:** This reminder is provided to call CATV system installer's attention to Article 820-40 of the National Electrical Code (Section 54 of Canadian Electrical Code, Part I), that provides guidelines for proper grounding and, in particular, specifies that the cable ground shall be connected to the grounding system of the building as close to the point of cable entry as practical.

**CAUTION:** FCC/CSA regulations state that any unauthorized changes or modifications to this equipment may void the user's authority to operate it.

**CAUTION:** To prevent electric shock, match the wide blade of plug to the wide slot, and fully insert the plug.

**Attention:** Pour éviter les chocs électriques, introduire la lame la plus large de la fiche dans la bome correspondante de la prise et pousser jusqu'au fond.

**Important:** One Federal Court has held that unauthorized recording of copyrighted TV programs is an infringement of U.S. copyright laws. Certain Canadian programs may also be copyrighted and any unauthorized recording in whole or in part may be in violation of these rights.

**TO PREVENT DAMAGE WHICH MAY RESULT IN FIRE OR ELECTRIC SHOCK HAZARD, DO NOT EXPOSE THIS APPLIANCE TO RAIN OR MOISTURE.**

### Read and follow these instructions when connecting and using your computer monitor:



- Unplug the monitor if you are not going to use it for an extensive period of time.
- Unplug the monitor if you need to clean it with a slightly damp cloth. The screen may be wiped with a dry cloth when the power is off. However, never use alcohol, solvents or ammonia-based liquids.
- Consult a service technician if the monitor does not operate normally when you have followed the instructions in this manual.
- The casing cover should be opened only by qualified service personnel.
- Keep the monitor out of direct sunlight and away from stoves or any other heat source.
- Remove any object that could fall into the vents or prevent proper cooling of the monitor's electronics.
- Do not block the ventilation holes on the cabinet.
- Keep the monitor dry. To avoid electric shock, do not expose it to rain or excessive moisture.
- If turning off the monitor by detaching power cable or DC power cord, wait for 6 seconds before attach the power cable or DC power cord for normal operation.
- To avoid the risk of shock or permanent damage to the set do not expose the monitor to rain or excessive moisture.
- When positioning the monitor, make sure the power plug and outlet are easily accessible.
- **IMPORTANT:** Always activate a screen saver program during your application. If a still image in high contrast remains on the screen for an extended period of time, it may leave an 'after-image' or 'ghost image' on the front of the screen. This is a well-known phenomenon that is caused by the shortcomings inherent in the LCD technology. In most cases the afterimage will disappear gradually over a period of time after the power has been switched off. Be aware that the after-image symptom cannot be repaired and is not covered under warranty.

## REGULATORY INFORMATION

### CE DECLARATION OF CONFORMITY

MMD declare under our responsibility that the product is in conformity with the following standards.

- EN60950-1:2001 (Safety requirement of Information Technology Equipment)
- EN55022:2006 (Radio Disturbance requirement of Information Technology Equipment)
- EN55024:1998+A1:2001+A2:2003 (Immunity requirement of Information Technology Equipment)
- EN61000-3-2:2006 (Limits for Harmonic Current Emission)
- EN61000-3-3:1995+A1:2001+A2:2005 (Limitation of Voltage Fluctuation and Flicker) following provisions of directives applicable.
- 2006/95/EC (Low Voltage Directive)
- 2004/108/EC (EMC Directive)
- 93/68/EEC (Amendment of EMC and Low Voltage Directive) and is produced by a manufacturing organization on ISO9000 level.

### FEDERAL COMMUNICATIONS COMMISSION (FCC) NOTICE (U.S. Only)



This equipment has been tested and found to comply with the limits for a Class B digital device, pursuant to Part 15 of the FCC Rules. These limits are designed to provide reasonable protection against harmful interference in a residential installation. This equipment generates, uses and can radiate radio frequency energy and, if not installed and used in accordance with the instructions, may cause harmful interference to radio communications. However, there is no guarantee that interference will not occur in a particular installation. If this equipment does cause harmful interference to radio or television reception, which can be determined by turning the equipment off and on, the user is encouraged to try to correct the interference by one or more of the following measures:

- Reorient or relocate the receiving antenna.
- Increase the separation between the equipment and receiver.
- Connect the equipment into an outlet on a circuit different from that to which the receiver is connected.
- Consult the dealer or an experienced radio/TV technician for help.



Changes or modifications not expressly approved by the party responsible for compliance could void the user's authority to operate the equipment.

Use only RF shielded cable that was supplied with the monitor when connecting this monitor to a computer device.

To prevent damage which may result in fire or shock hazard, do not expose this appliance to rain or excessive moisture.

THIS CLASS B DIGITAL APPARATUS MEETS ALL REQUIREMENTS OF THE CANADIAN INTERFERENCE- CAUSING EQUIPMENT REGULATIONS.



This device complies with Part 15 of the FCC Rules. Operation is subject to the following two conditions: (1) this device may not cause harmful interference, and (2) this device must accept any interference received, including interference that may cause undesired operation.

## POLISH CENTER FOR TESTING AND CERTIFICATION NOTICE

The equipment should draw power from a socket with an attached protection circuit (a three-prong socket). All equipment that works together (computer, monitor, printer, and so on) should have the same power supply source.

The phasing conductor of the room's electrical installation should have a reserve short-circuit protection device in the form of a fuse with a nominal value no larger than 16 amperes (A).

To completely switch off the equipment, the power supply cable must be removed from the power supply socket, which should be located near the equipment and easily accessible.

A protection mark "B" confirms that the equipment is in compliance with the protection usage requirements of standards PN-93/T-42107 and PN-89/E-06251.

### *Wymagania Polskiego Centrum Badań i Certyfikacji*

Urządzenie powinno być zasilane z gniazda z przyłączonym obwodem ochronnym (gniazdo z kolkiem). Współpracujące ze sobą urządzenia (komputer, monitor, drukarka) powinny być zasilane z tego samego źródła.

Instalacja elektryczna pomieszczenia powinna zawierać w przewodzie fazowym rezerwową ochronę przed zwarciami, w postaci bezpiecznika o wartości znamionowej nie większej niż 16A (amperów).

W celu całkowitego wyłączenia urządzenia z sieci zasilania, należy wyjąć wtyczkę kabla zasilającego z gniazda, które powinno znajdować się w pobliżu urządzenia i być łatwo dostępne.

Znak bezpieczeństwa "B" potwierdza zgodność urządzenia z wymaganiami bezpieczeństwa użytkowania zawartymi w PN-93/T-42107 i PN-89/E-06251.

### *Pozostałe instrukcje bezpieczeństwa*

- Nie należy używać wtyczek adapterowych lub usuwać kolka obwodu ochronnego z wtyczki. Jeżeli konieczne jest użycie przedłużacza to należy użyć przedłużacza 3-żyłowego z prawidłowo połączonym przewodem ochronnym.
- System komputerowy należy zabezpieczyć przed nagłymi, chwilowymi wzrostami lub spadkami napięcia, używając eliminatora przepięć, urządzenia dopasowującego lub bezzakłóceniewego źródła zasilania.
- Należy upewnić się, aby nic nie leżało na kablach systemu komputerowego, oraz aby kable nie były umieszczone w miejscu, gdzie można byłoby na nie nadeptywać lub potykać się o nie.
- Nie należy rozlewać napojów ani innych płynów na system komputerowy.
- Nie należy wpychać żadnych przedmiotów do otworów systemu komputerowego, gdyż może to spowodować pożar lub porażenie prądem, poprzez zwarcie elementów wewnętrznych.
- System komputerowy powinien znajdować się z dala od grzejników i źródeł ciepła. Ponadto, nie należy blokować otworów wentylacyjnych. Należy unikać kładzenia luźnych papierów pod komputer oraz umieszczania komputera w ciasnym miejscu bez możliwości cyrkulacji powietrza wokół niego.

## ELECTRIC, MAGNETIC AND ELECTROMAGNETIC FIELDS ("EMF")

1. MMD manufactures and sells many products targeted at consumers, which, like any electronic apparatus, in general have the ability to emit and receive electromagnetic signals.
2. One of MMD's leading Business Principles is to take all necessary health and safety measures for our products, to comply with all applicable legal requirements and to stay well within the EMF standards applicable at the time of producing the products.
3. MMD is committed to develop, produce and market products that cause no adverse health effects.
4. MMD confirms that if its products are handled properly for their intended use, they are safe to use according to scientific evidence available today.
5. MMD plays an active role in the development of international EMF and safety standards, enabling MMD to anticipate further developments in standardisation for early integration in its products.

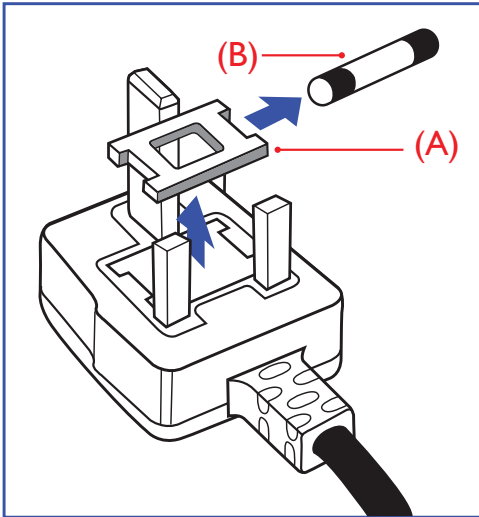
**INFORMATION FOR UK ONLY****WARNING - THIS APPLIANCE MUST BE EARTHED.****Important:**

This apparatus is supplied with an approved moulded 13A plug. To change a fuse in this type of plug proceed as follows:

1. Remove fuse cover and fuse.
2. Fit new fuse which should be a BS 1362 5A, A.S.T.A. or BSI approved type.
3. Refit the fuse cover.

If the fitted plug is not suitable for your socket outlets, it should be cut off and an appropriate 3-pin plug fitted in its place.

If the mains plug contains a fuse, this should have a value of 5A. If a plug without a fuse is used, the fuse at the distribution board should not be greater than 5A.

**NOTE:** The severed plug must be destroyed to avoid a possible shock hazard should it be inserted into a 13A socket elsewhere.

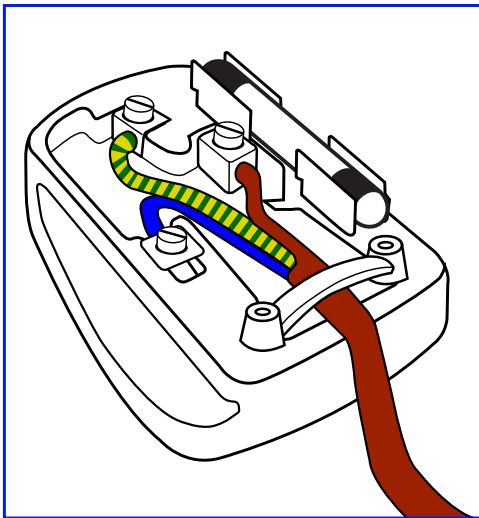
**How to connect a plug**

The wires in the mains lead are coloured in accordance with the following code:

BLUE - "NEUTRAL" ("N")

BROWN - "LIVE" ("L")

GREEN & YELLOW - "EARTH" ("E")

1. The GREEN AND YELLOW wire must be connected to the terminal in the plug which is marked with the letter "E" or by the Earth symbol or coloured GREEN or GREEN AND YELLOW.
2. The BLUE wire must be connected to the terminal which is marked with the letter "N" or coloured BLACK.
3. The BROWN wire must be connected to the terminal which marked with the letter "L" or coloured RED.

Before replacing the plug cover, make certain that the cord grip is clamped over the sheath of the lead - not simply over the three wires.

## 中国电子信息产品污染控制标识要求（中国RoHS法规标示要求） 产品中有毒有害物质或元素 的名称及含量

部件名称	有毒有害物质或元素					
	铅 (Pb)	汞 (Hg)	镉 (Cd)	六价铬 (Cr 6+)	多溴联苯 (PBB)	多溴二苯醚 (PBDE)
外壳	○	○	○	○	○	○
液晶面板	×	×	○	○	○	○
电路板组件	×	○	○	○	○	○
附件 (遥控器, 电源线, 连接线)	×	○	○	○	○	○
遥控器电池	×	○	○	○	○	○

○：表示该有毒有害物质在该部件所有均质材料中的含量均在 SJ/T11363-2006 标准规定的限量要求以下。

×：表示该有毒有害物质至少在该部件的某一均质材料中的含量超出 SJ/T11363-2006 标准规定的限量要求。



### 环保使用期限

此标识指期限(十年)，电子信息产品中含有的有毒有害物质或元素在正常使用的条件下不会发生外泄或突变，电子信息产品用户使用该电子信息产品不会对环境造成严重污染或对其人身、财产造成严重损害的期限。



## NORTH EUROPE (NORDIC COUNTRIES) INFORMATION

Placering/Ventilation

### **VARNING:**

FÖRSÄKRA DIG OM ATT HUVUDBRYTARE OCH UTTAG ÄR LÄTÅTKOMLIGA, NÄR DU STÄLLER DIN UTRUSTNING PÅPLATS.

Placering/Ventilation

### **ADVARSEL:**

SØRG VED PLACERINGEN FOR, AT NETLEDNINGENS STIK OG STIKKONTAKT ER NEMT TILGÆNDELIGE.

Paikka/Ilmankierto

### **VAROITUS:**

SIJOITA LAITE SITEN, ETTÄ VERKKOJOHTO VOIDAAN TARVITTAESSA HELPOSTI IRROTTAA PISTORASIESTA.

Plassering/Ventilasjon

### **ADVARSEL:**

NÅR DETTE UTSTYRET PLASSERES, MÅ DU PASSE PÅ AT KONTAKTENE FOR STØMTILFØRSEL ER LETTE Å NÅ.

## END-OF-LIFE DISPOSAL

Your new TV/Monitor contains materials that can be recycled and reused. Specialized companies can recycle your product to increase the amount of reusable materials and to minimize the amount to be disposed of.

Please find out about the local regulations on how to dispose of your old monitor from your local Philips dealer.

### **(For customers in Canada and U.S.A.)**

This product may contain lead and/or mercury. Dispose of in accordance to local-state and federal regulations.

For additional information on recycling contact [www.eia.org](http://www.eia.org) (Consumer Education Initiative)

## WASTE ELECTRICAL AND ELECTRONIC EQUIPMENT-WEEE

### Attention users in European Union private households



This marking on the product or on its packaging illustrates that, under European Directive 2002/96/EG governing used electrical and electronic appliances, this product may not be disposed of with normal household waste. You are responsible for disposal of this equipment through a designated waste electrical and electronic equipment collection. To determine the locations for dropping off such waste electrical and electronic, contact your local government office, the waste disposal organization that serves your household or the store at which you purchased the product.

### Attention users in United States:

Like all LCD products, this set contains a lamp with Mercury. Please dispose of according to all Local, State and Federal Laws. For the disposal or recycling information, contact: [www.mygreenelectronics.com](http://www.mygreenelectronics.com) or [www.eiae.org](http://www.eiae.org).

# Contents

**BDL3215E/BDL4225E** monitor pack\* should include:

- LCD monitor
- Power cord (1.8 m)
- VGA Signal Cable (1.8 m)
- User Manual
- Remote Control and AAA Batteries
- Quick installation guide.

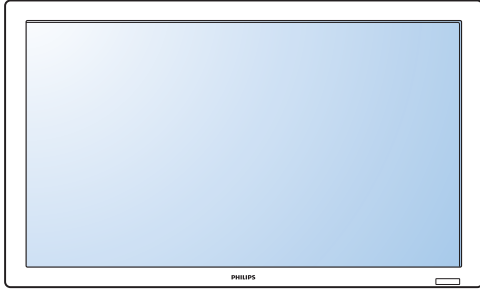

\* The following components are prepared as options.

- Table stand
- Main switch cover
- Screw for Main Switch cover x 2
- BNC TO RCA adapter x 5
- Logo guider

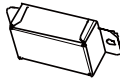

Main switch cover

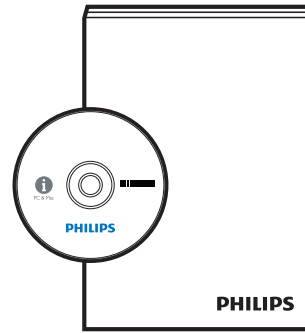

User's Manual

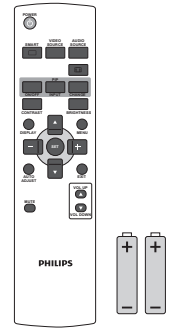

Remote Control and AAA Batteries

\* The supplied power cord varies depending on destination.



For EU



For China



For North America



For UK

## Power cord

\* Please make sure that for all other regions, apply a power cord that conforms to the AC voltage of the power socket and has been approved by and complies with the safety regulations of the particular country

\* You might like to save the package box and packing material for shipping the monitor.



Screw for Main switch cover  
(3 x 6) x 2

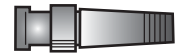

BNC-RCA adapter x 5

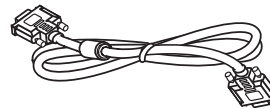

Video Signal Cable  
(D-SUB to D-SUB Cable)

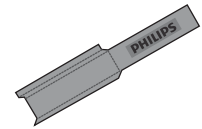

Logo guider

# Elements Name and Functions

## Control Panel

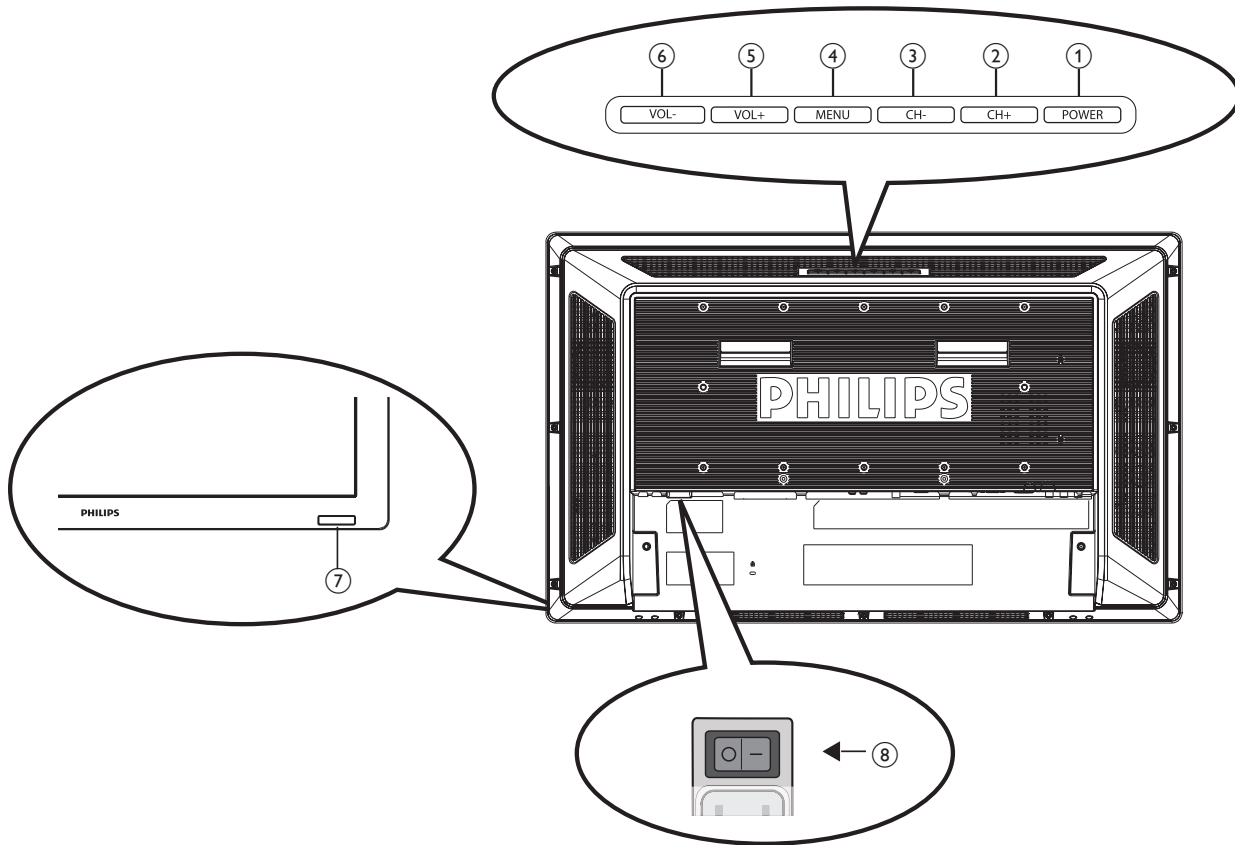

- ① **POWER button (⏻):** To switch the power on/off.
- ② **CH (+) button:** To move the highlight bar up to adjust the selected item while OSD menu is on.
- ③ **CH (-) button:** To move the highlight bar down to adjust the selected item while OSD menu is on.
- ④ **MENU button:** To return to previous menu while OSD menu is on or to activate the OSD menu when the OSD menu is off.
- ⑤ **VOL (+) button:** To increase the adjustment while OSD menu is on, or to increase the audio output level while the OSD menu is off.
- ⑥ **VOL (-) button:** To decrease the adjustment while OSD menu is on, or to decrease the audio output level while the OSD menu is off.
- ⑦ **Remote control sensor and Power indicator:** To receive the IR signal from the remote control. The indicator would show blue when the LCD monitor is active, and would turn blank when the LCD is POWER OFF. While in the case of the system is in power save mode, it would show amber. When SCHEDULE is enabled, it would show blinking blue.
- ⑧ **Main Power Switch:** To turn the main power on/off.

### NOTE:

**Keyboard Control Lock Mode:** This function completely disables the access to all Keyboard Control functions. To enable the keyboard control lock, press both “CH+” and “CH-” buttons and hold down continuously for more than 3 seconds. To recover back to the user mode, press both “CH+” and “CH-” buttons and hold continuously for three 3 seconds.

# Terminal Panel

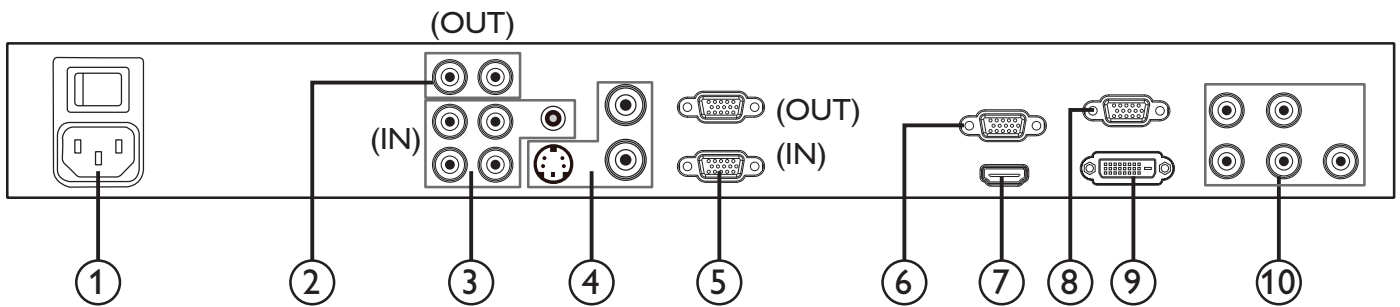
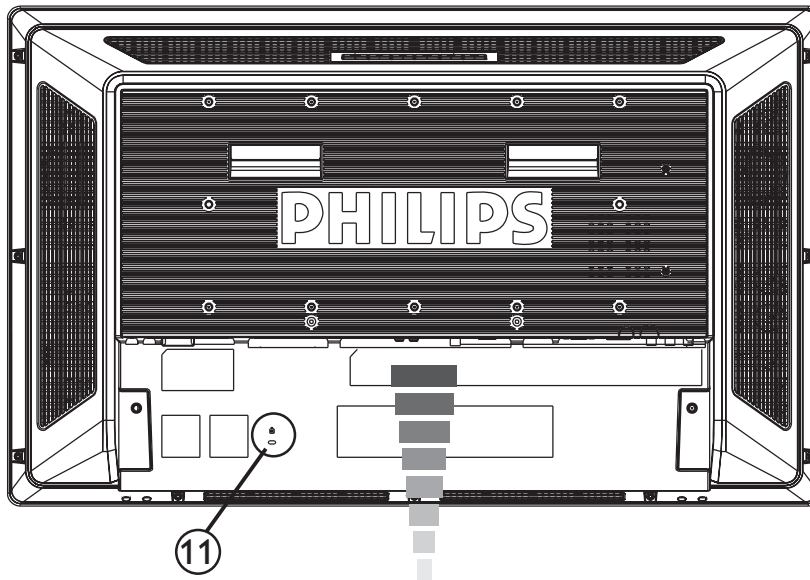

① **AC IN connector**

Connect the supplied power cord to the wall outlet.

② **AUDIO OUT**

To output the audio signal from AUDIO IN 1, 2, or 3 jack to an external device (Stereo receiver, amplifier, etc.).

③ **AUDIO IN 1, 2, 3**

To input audio signal from an external equipment such as computers, VCRs, or DVD players.

④ **VIDEO INPUT/OUTPUT Connector**

- **VIDEO IN connector (BNC):** To input composite video signal.
- **VIDEO OUT connector (BNC):** To output composite video signal from VIDEO IN connector.
- **S-VIDEO IN connector (Mini DIN 4 pin):** To input S-VIDEO (Y/C separate signal).

⑤ **EXTERNAL CONTROL (D-Sub 9 pin)**

Connect RS-232C input from external equipment such as computers for the use of loop through function.

⑥ **VGA OUT (mini D-Sub 15 pin)**

To output the signal from VGA IN and RGB component.

⑦ **HDMI IN**

Connecting equipment such as DVD players, HDTV devices, or Set-Top-Box.

⑧ **VGA IN (mini D-sub 15 pin)**

To input analog RGB signals from a computer or from other RGB equipment.

⑨ **DVI-D INPUT**

To input digital RGB signals from a computer or other HDTV device with digital RGB output.

\* This connector does not support analog input.

⑩ **VGA (BNC) [R, G, B, H, V] or COMPONENT [Y, Cb/Pb, Cr/Pr]**

To input analog RGB or Y, Cb/Pb,Cr/Pr signals from DVD players, HDTV decoders, set-top-box or game consoles etc.

⑪ **Kensington Lock**

For security and theft prevention.

## Remote Control

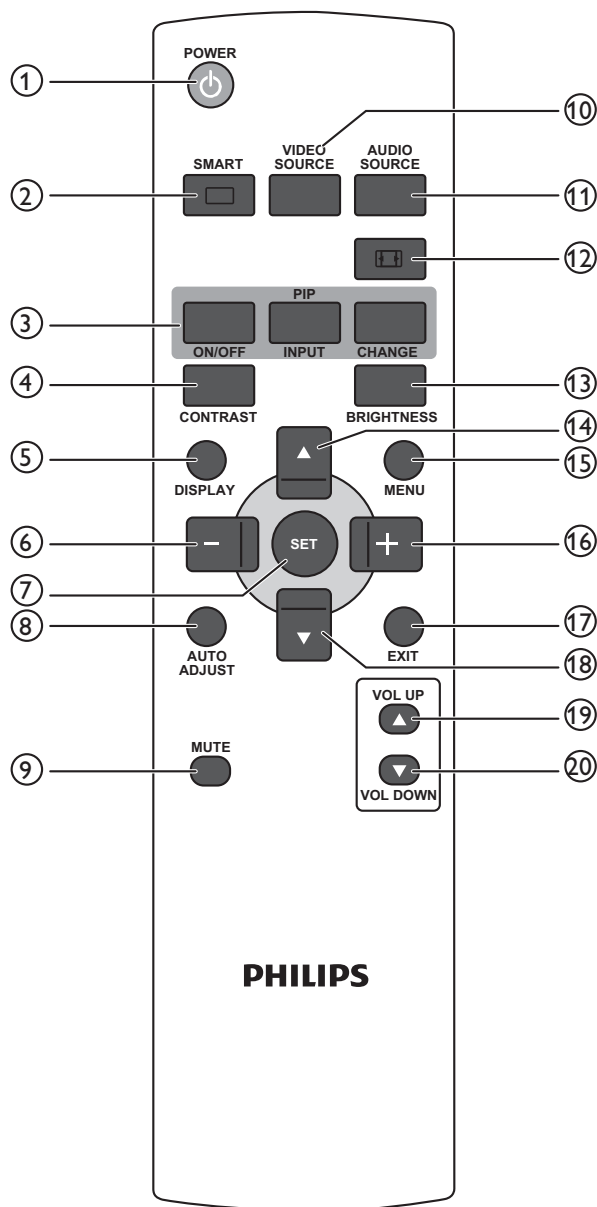

### ① POWER button

- To turn the power on/off.
- If LED Power Indicator on the monitor is not lightening, then the remote control will not work.

### ② SMART button

- To select smart picture mode from [HIGHBRIGHT], [STANDARD], [sRGB], [CINEMA].
- HIGHBRIGHT:** for moving image such as Video
- STANDARD:** for images (Factory setting)
- sRGB:** for text based images
- CINEMA:** for movies.

### ③ PIP (Picture In Picture) button

- ON/OFF button:** To turn PIP mode ON/OFF.
- INPUT button:** To select the input signal for the sub-picture.
- CHANGE button:** To exchange between the main picture and sub-picture.

**NOTE:** The "PIP" and "POP" modes do not work if the screen size is "CUSTOM" or "REAL".

### ④ CONTRAST button

To start **CONTRACT** OSD selection, and then press "+" or "-" button to adjust the value.

### ⑤ DISPLAY button

To turn on/off the setting information displayed on the right-up corner of the screen.

### ⑥ "-" button

- To decrease the adjustment with OSD menu.
- To move the sub-picture left when in "PIP" mode.

### ⑦ SET button

To activate the setting with OSD menu.

### ⑧ AUTO ADJUST button

To execute the **AUTO ADJUST** function.

### ⑨ MUTE button

Mutes or restores audio output.

### ⑩ VIDEO SOURCE button

To set video source by toggle selection from [HDMI], [DVI-D], [VGA], [COMPONENT], [S-VIDEO], [VIDEO] and [VGA(BNC)].

### ⑪ AUDIO SOURCE button

To set audio source by toggle selection from [AUDIO 1] to [AUDIO2], [AUDIO3] and [HDMI].

**NOTE:** [HDMI] is only selectable when video source is set to [HDMI].

### ⑫ SIZE button

To set picture size by toggle selection from [FULL], [NORMAL], [CUSTOM], [DYNAMIC] and [REAL].

**NOTE:** [DYNAMIC] is for video mode only.

### ⑬ BRIGHTNESS button

To start the **BRIGHTNESS** OSD selection, and then press "+" or "-" button to adjust the value.

### ⑭ ▲ button

- To move the highlight bar up to adjust the selected item when OSD menu is on.
- To move the sub-picture up when in "PIP" mode.

### ⑮ MENU button

To turn the OSD menu on/off.

### ⑯ "+" button

- To increase the adjustment with OSD menu.
- To move the sub-picture right when in "PIP" mode.

### ⑰ EXIT button

To return to a previous channel or menu screen.

### ⑱ ▼ button

- To move the highlight bar down to adjust the selected item when OSD menu is on.
- To move the sub-picture down when in "PIP" mode.

### ⑲ VOL UP button

To increase the audio output level.

### ⑳ VOL DOWN button

To decrease the audio output level.

## Operating Range for the Remote Control

Use the remote control by pointing it towards the remote control sensor on the LCD monitor.

Use the remote control unit within a distance of about 7 m/23 ft from the front of the remote control sensor on the LCD monitor and within horizontal and vertical angle  $30^\circ$  with a distance of about 3 m/10 ft.

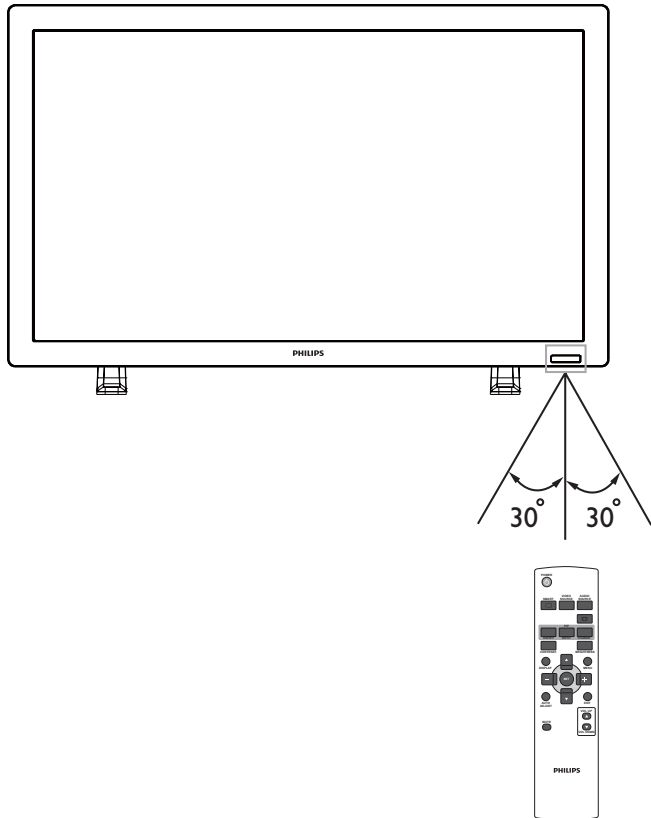

## Handling the remote control

- Do not subject to strong shock.
- Do not allow water or other liquid to splash the remote control. If the remote control gets wet, wipe it dry immediately.
- Avoid exposure to heat and steam.
- Other than to install the batteries, do not open the remote control.

### NOTE:

The remote control system may not function when direct sunlight or strong illumination strikes the remote control sensor of the LCD monitor, or when there is an obstacle in the radiation path.

# How to mount or attach table stand to the LCD Monitor

Installs the LCD monitor in one of the following two ways:

## Way I: Attach and remove the table stand

### How to install table stand

1. Please turn the monitor off.
2. After inserting table stand in guide block, fasten the thumbscrews on both sides of the monitor.

### NOTE:

Install the table stand with their longer portions directing to the front.

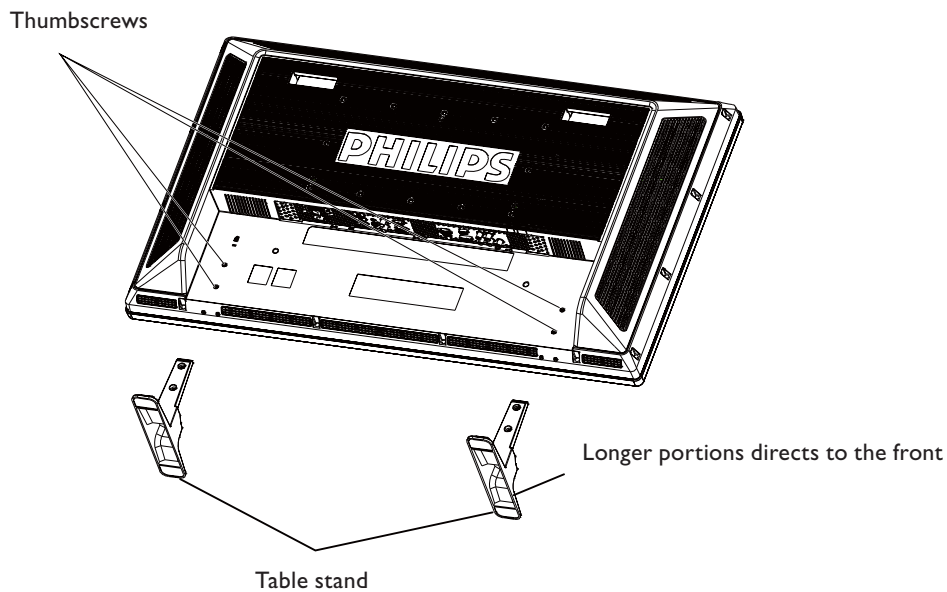

### In the upright position

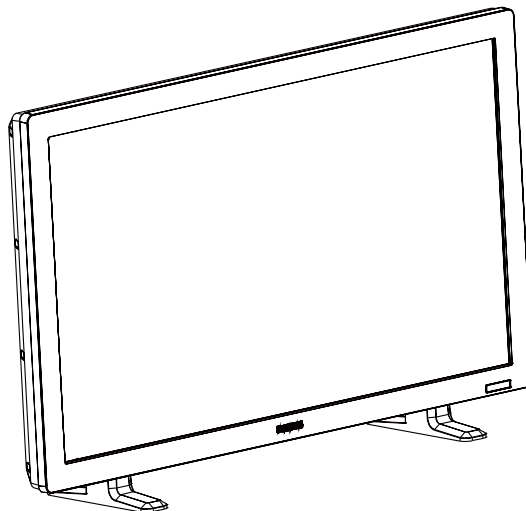

### How to remove the table stand

1. Spread the protective sheet on the flat surface.
2. Make the monitor lying on the protective sheet.
3. Remove the screws using a screwdriver and place them in a safe place for reuse.

## Way II: Mount the monitor on the wall

Before mounting the monitor to the wall, make sure that the system has been power-off and you have obtain a standard wall-mounting kit (commercially available). Using mounting interface that comply with TÜV-GS and/or UL1678 standard in North America is recommended.

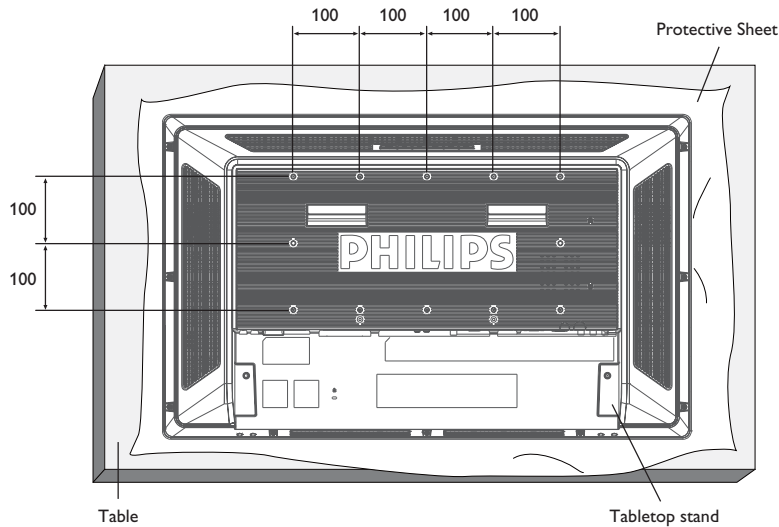

1. Lay a protective sheet on a table, which was wrapped around the monitor when it was packaged, beneath the screen surface so as not to scratch the screen face.
2. This device cannot be used or installed without the Tabletop Stand or other mounting accessory. Make sure all these stuffs are ready for wall-mount installation.
3. Follow the instructions that come with the base mounting kit. Failure to follow correct mounting procedures could result in damage to the equipment or injury to the user or installer. Product warranty does not cover damage caused by improper installation.
4. For the wall-mounting kit, use M6 mounting screws (having a length 10 mm longer than the thickness of the mounting bracket) and tighten them securely. (Recommended torque: 470 - 635N•cm).

### Caution:

For preventing the monitor from falling.

- Install the monitor with metal brackets for wall or ceiling installation (commercially available) on your own responsibility. For detailed procedures of installation, refer to the instructions of the metal brackets.
- To lessen the probability of injury and damage resulting from fall of the monitor in case of earthquake or other disaster, be sure to consult the bracket manufacturer for installation location.

## Ventilation Requirements for enclosure locating

To allow heat to disperse, leave space between surrounding objects as shown in the diagram below.

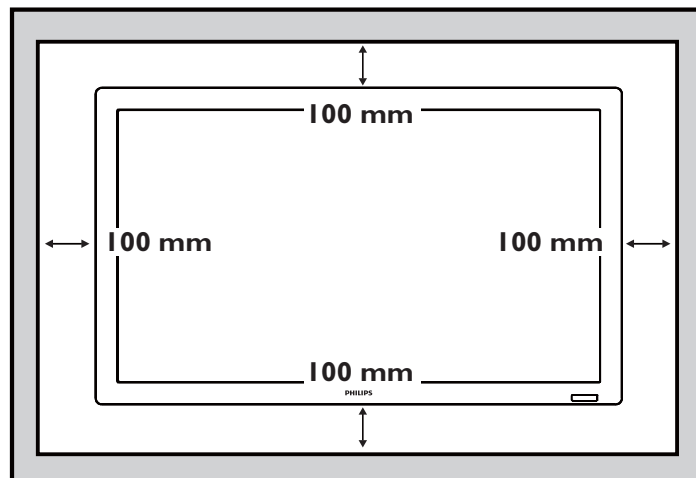



# Setup Procedure

## 1. Install the system on the right location

### CAUTION:

- THE LCD MONITOR MUST BE MOVED OR INSTALLED BY TWO OR MORE PERSONS. (For 42" only)

Failure to follow this caution may result in injury if the LCD monitor falls.

- DO NOT ATTEMPT TO INSTALL THE LCD MONITOR BY YOURSELF.

The LCD display must be installed by a qualified technician. Contact your dealer for more information.

- DO NOT MOUNT OR OPERATE THE DISPLAY UPSIDE DOWN, FACE UP, OR FACE DOWN.
- DO NOT INSTALL THE LCD MONITOR WHERE IT WILL BE EXPOSED TO DIRECT SUNLIGHT.

Failure to follow this caution will result in display defects.

### IMPORTANT:

Lay the protective sheet, which was wrapped around the LCD monitor when it was packaged, beneath the LCD monitor so as not to scratch the panel.

## 2. Install the remote control batteries

The remote control is powered by 1.5V AAA batteries. To install or replace batteries:

1. Press and slide to open the cover.
2. Align the batteries according to the (+) and (-) indications inside the case.
3. Replace the cover.

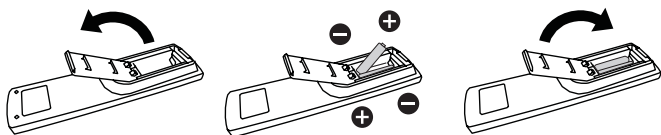

### CAUTION:

Incorrect use of batteries can result in leaks or bursting. Be careful especially about the following points.

- Place "AAA" batteries matching the + and - signs on each battery to the + and - signs of the battery compartment.
- Do not mix battery types.
- Do not combine new batteries with used ones. It causes shorter battery life or leakage of batteries.
- Remove dead batteries immediately to prevent battery liquid from leaking into the battery compartment. Don't touch exposed battery acid, it cause damage to your skin.

### NOTE:

If you do not intend to use the Remote Control for a long period, remove the batteries.

## 3. Connect to external equipment

- To protect the connected equipment, turn off the main power before making connections.
- Please refer to section "Connectivity" P.17~P.21 for operations.

## 4. Connect power cord

- The power outlet socket should be installed as near to the equipment as possible, and should be easily accessible.
- Fully insert the prongs into the power outlet socket. Loose connection may cause noise.

### NOTE:

Please refer to "SAFETY INSTRUCTIONS" section of this manual for proper selection of AC power cord.

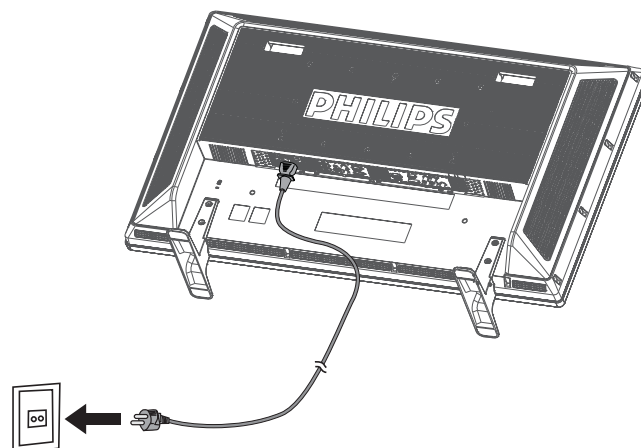

## 5. Turn on the power of the attached external equipment

When connected with a computer, turn the computer power on first.

## 6. Operate the attached external equipment

Display the signal from the external equipment.

## 7. Adjust the sound

Make adjustments to decrease or increase volume if required.

## 8. Adjust the screen

Make adjustments to the display position or settings if required.

## 9. Adjust the image

Make adjustments of brightness or contrast if required.

## 10. Recommended Adjustment

To reduce the risk of "image persistence", please adjust the following items based on the application being used:

"POWER SAVE", "PANEL SAVING", "DATE AND TIME", "SCHEDULE".

## 11. To prevent the main power switch from being changed

To prevent the possibility of main power switch being carelessly pushed, please attach the main switch cover (accessory) onto it.

### NOTE:

Remove main power switch cover to turn off the display.

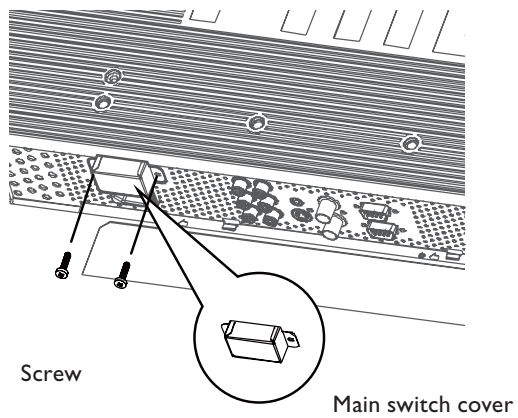

# Install the LCD Monitor in Portrait Mode

BDL3215E/BDL4225E can be installed in portrait position, under the following conditions:

## Caution:

Portrait mode is effective only when wall-mounted or ceiling-mounted. The table stand can not be used for the monitor in portrait position. Placing the monitor in portrait position, will shorten the average life of the LCD backlight.

Operational Environment (Temperature) shall be limited, as shown below:

<b>Operational Environment</b>	Temperature	5 - 35 °C / 41 - 95 °F
	Humidity	20 - 80 % (Without condensation)

Please orientate the monitor in the direction shown as the right figure:

Do not place monitor in landscape in any other manner.

## How to set-up

1. Remove the table stand if they are attached.
2. The “**PHILIPS**” logo should be on the LEFT side when facing the monitor.

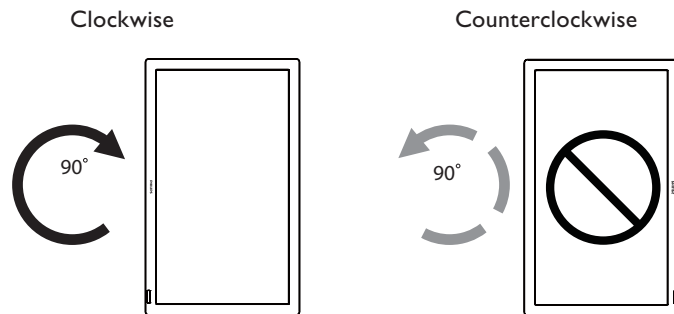

## How to Remove the Logo for landscape mode?

1. Prepare a piece of paper with a cutting area of logo as a protector to prevent the front bezel from scratching.
2. Using a knife, carefully remove the logo sticker with the paper placing beneath.
3. Tear off the logo sticker.

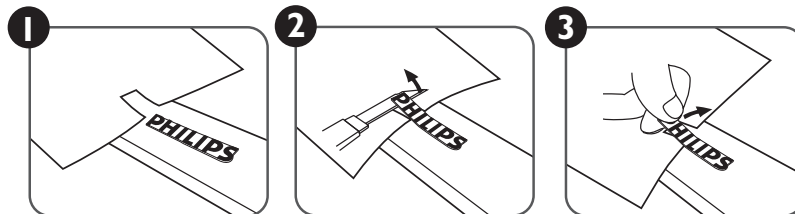

## How to Use the Logo Guider for Portrait Mode?

- (a) Before applying, make sure the guider is well shaped. The “PHILIPS” sticker attached on the end of it could be folded back as figure (a).
- (b) Turn back the logo end of the guider and remove the sticky tape of the logo.
- (c) Slide the logo guider along the short side of the front bezel as figure c & then return the logo end of the guider back to the right side.
- (d) With your left hand fixing the guider, scrunch the logo by your right hand to make it stuck firmly on the front bezel.
- (e) Remove the guider and leave the logo over the front bezel.

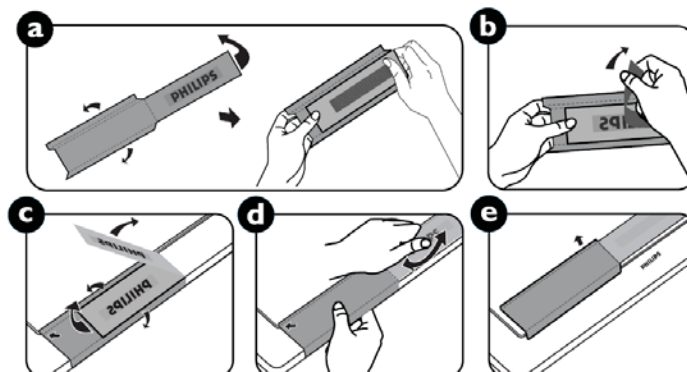

# Connectivity

## Before making connections:

- First turn off the power of all the attached equipments before making connections.
- Refer to the user manual included in each separate piece of equipment.

## Connectivity Diagram

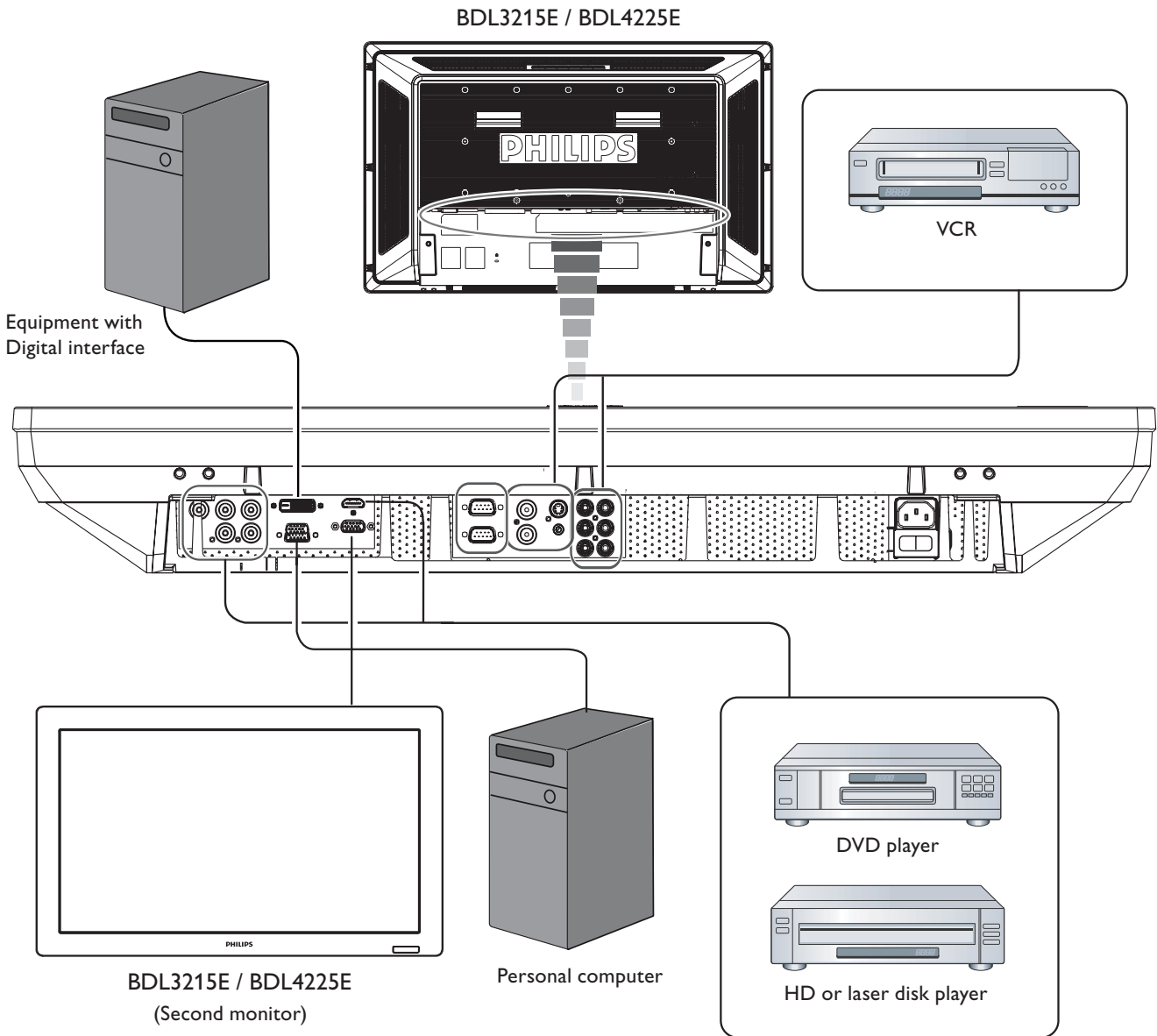

## Connecting to a Personal Computer

As you finish the connection between the computer and the LCD monitor, you could play the contents in the computer and display them on the LCD monitor.

### Connecting the LCD Monitor to a Personal Computer

- To achieve this, apply the supplied VGA signal cable (mini D-sub 15 pin to mini D-sub 15 pin) to make connection between PC and LCD monitor (VGA IN connector).
- When connecting more than one LCD monitors to PC, apply another VGA signal cable (mini D-sub 15 pin to mini D-sub 15 pin; it's commercially available) to make connection between LCD monitor (VGA OUT connector) and the other (VGA IN connector).
- The AUDIO IN 1, 2, 3 or HDMI can be connected for audio input using RCA cable. After choosing one of the AUDIO IN connectors, you might need to select AUDIO 1, 2, 3 or HDMI using the AUDIO SOURCE button on the remote control. HDMI (for audio) is selectable only when HDMI (for video) is selected.
- When connecting more than one LCD monitors to PC, apply RCA cable to make connection between LCD monitor (AUDIO OUT connector) and the other (AUDIO IN 1, 2, 3). HDMI source is not suitable for this case.

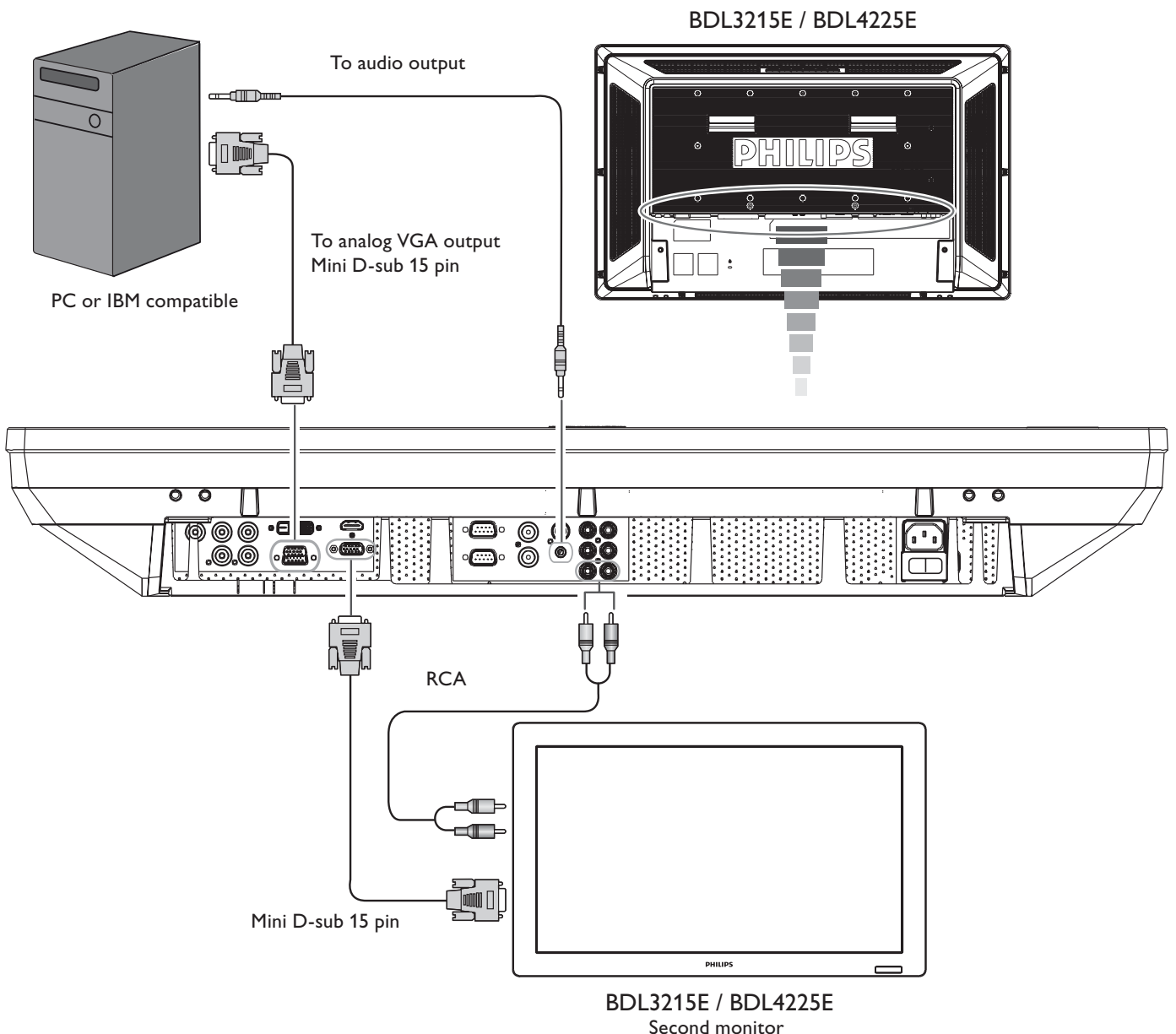

## Connecting to a Digital Interface Equipment

Connections can be made between LCD monitor and other digital equipment that is equipped with a digital interface compliant with DVI (Digital Visual Interface) standard.

### Connect the LCD Monitor to a Computer with a Digital Output

- HDMI IN connector accepts HDMI cable.
- HDMI IN connector can receive video from HDMI source (applying a HDMI to HDMI cable) or DVI-D source (applying a HDMI to DVI cable) of PC.
- To ensure the display quality, use quality prescribed cables with DVI standards.
- The AUDIO IN 1, 2, 3 or HDMI connector can be chosen to receive audio source. Select AUDIO 1, 2, 3 or HDMI from the AUDIO SOURCE button on the remote control. HDMI (for audio) is only selectable only when HDMI (for video) is selected.
- Note that the signal input from HDMI connector cannot be output to the VGA OUT connector.

Equipment with digital interface such as personal computer with VGA output (TMDS)

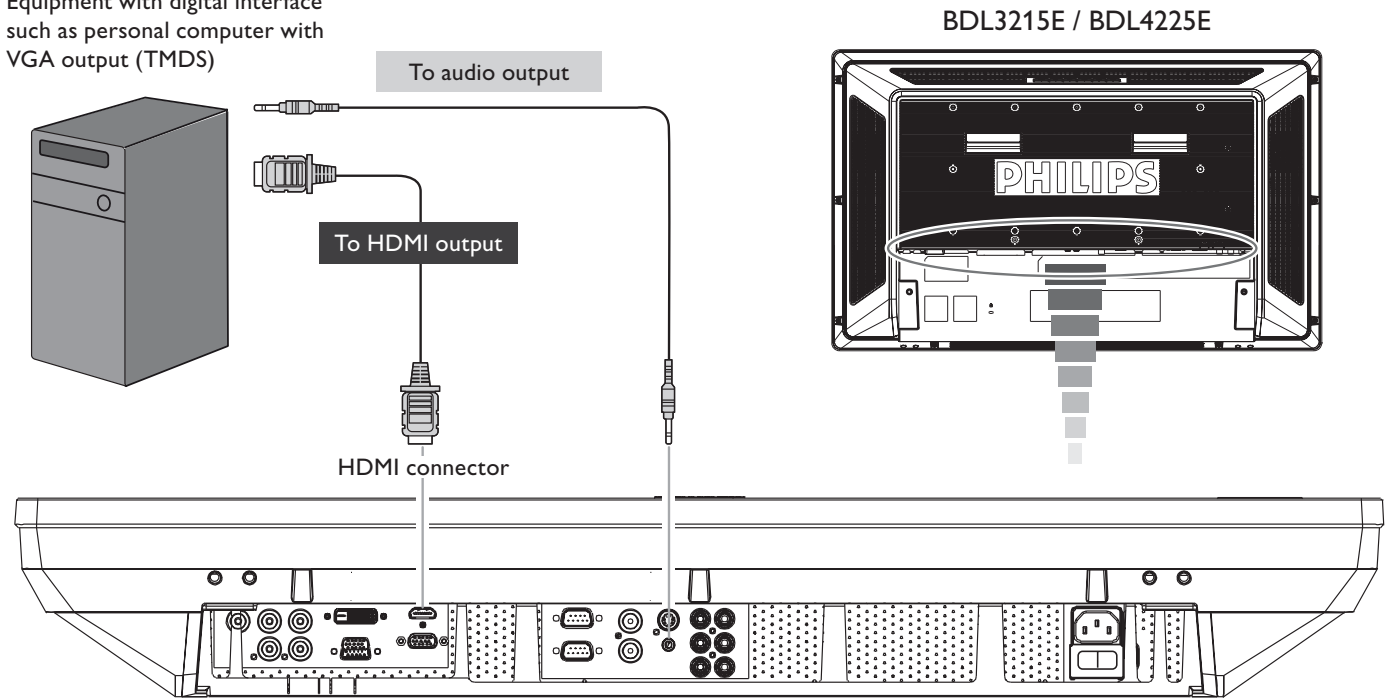

## Connecting to a DVD Player

As you finish the connection between the DVD player and the LCD monitor, you could display the contents from the played DVD on the LCD monitor. You might like to refer to your DVD player's manual for further information.

### Connect the LCD Monitor to a DVD Player

- To achieve this, apply component (YPbPr) cable to make connection between DVD player (Y, Cb/Pb, Cr/Pr Out) and LCD monitor (COMPONENT/ YPbPr connector). If your DVD player supports HDMI signal, apply HDMI to HDMI cable for the connection.
- The AUDIO IN 2, 3 (both of RCA connector type) can be used for audio input. Select [AUDIO 1] (for 3.5φ phone jack), [AUDIO 2], [AUDIO 3] or [HDMI] from the AUDIO SOURCE button on the remote control. HDMI (for audio) is selectable only when HDMI (for video) is selected.

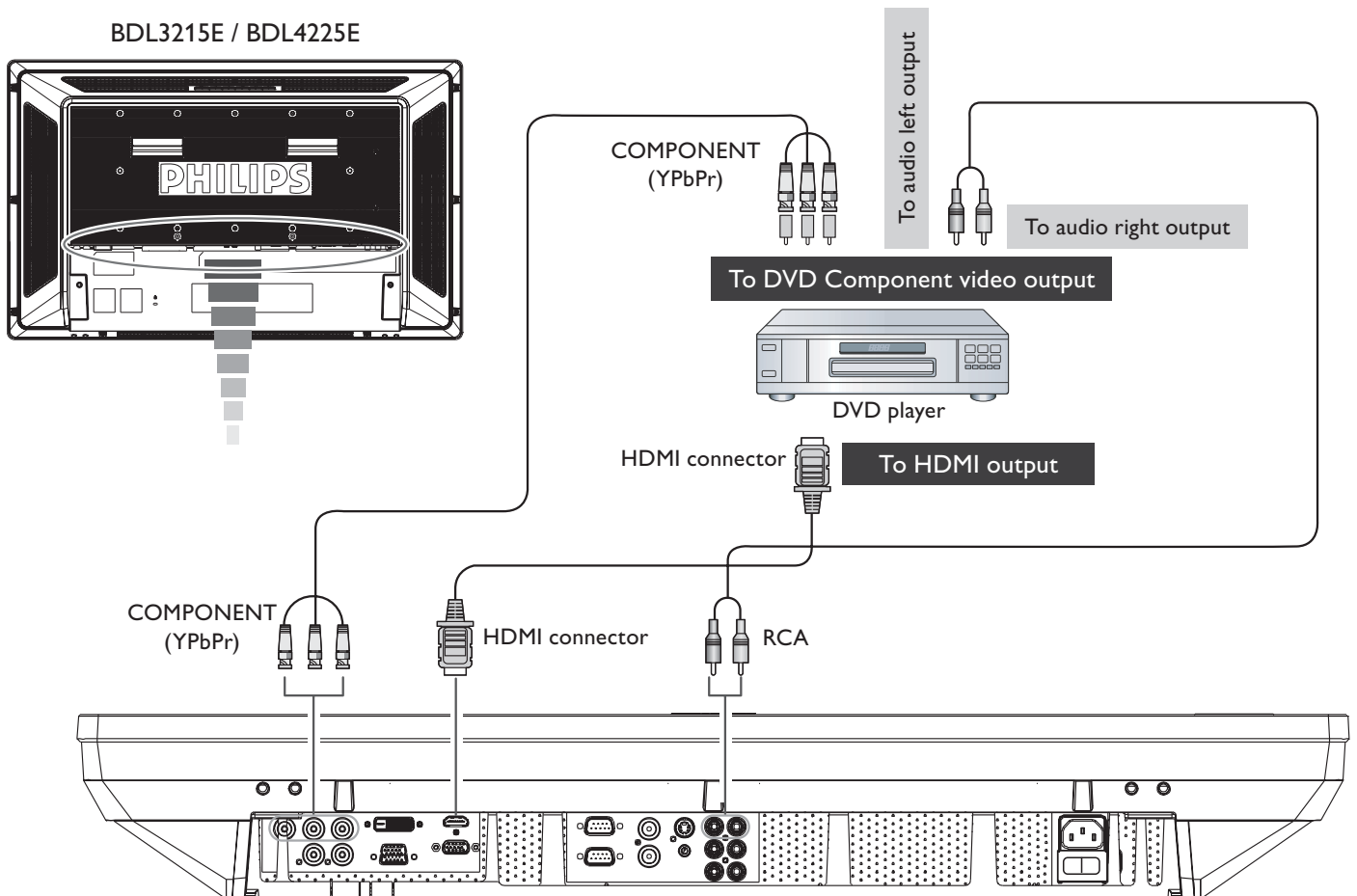

## Connecting to a Stereo Amplifier

You can connect stereo amplifier to your LCD monitor. Refer to the amplifier's manual for further information.

### Connect the LCD Monitor to a Stereo Amplifier

- Turn on the LCD monitor and the amplifier only after all connections have been connected.
- Apply RCA cable to make connections between the amplifier (audio in) and the LCD monitor (audio out).
- Do not reverse audio left and right jacks.
- For the preferred audio signal, select [AUDIO1], [AUDIO2], [AUDIO3] or [HDMI] from the AUDIO SOURCE button on the remote control. HDMI (for audio) is selectable only when HDMI (for video) is selected.
- AUDIO OUT RCA connectors output sound from the selected AUDIO SOURCE.

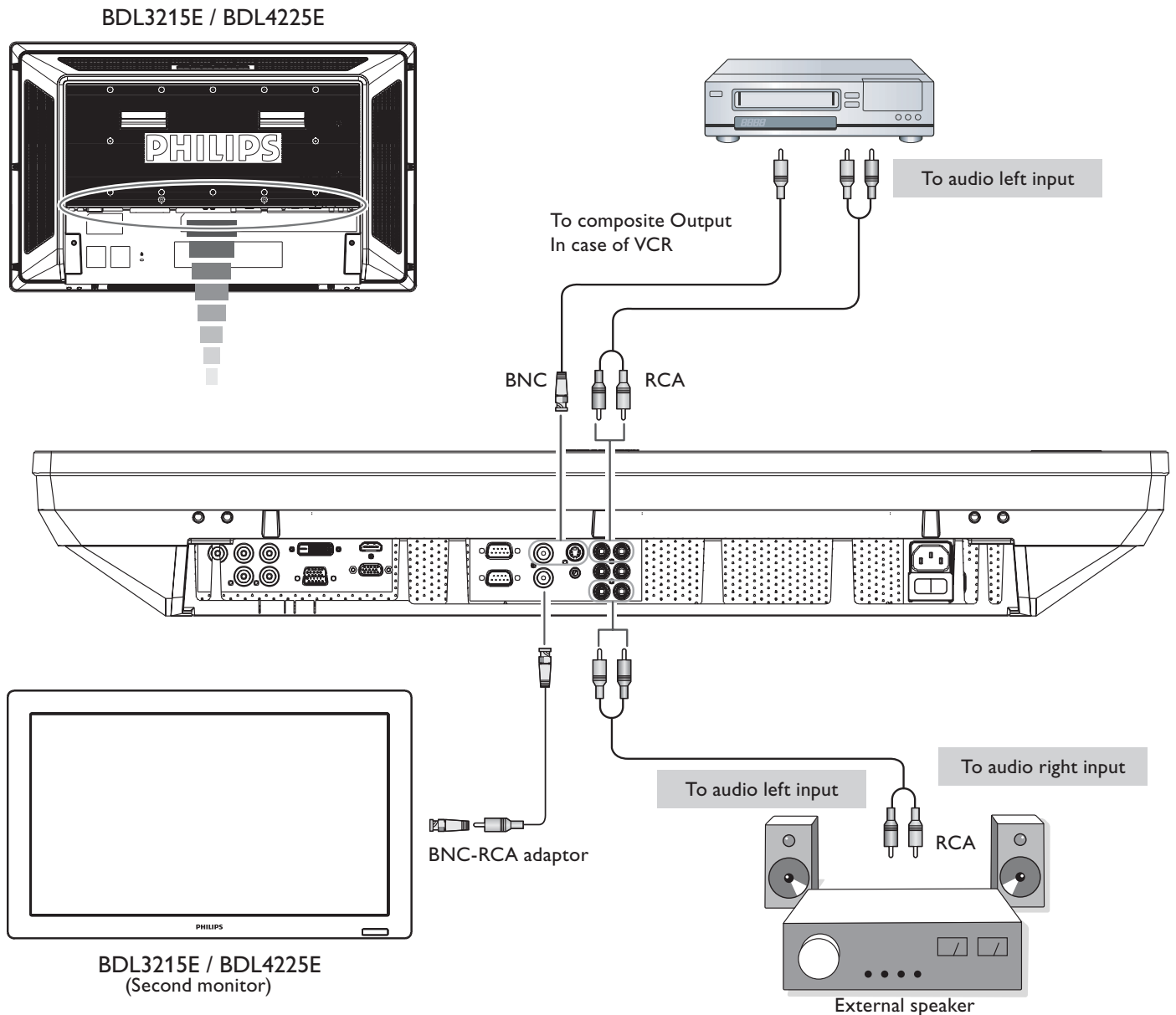



# Basic Operation

## Power ON and OFF Modes

The LCD monitor power indicator will turn blue while powered on and will turn blank while powered off. The monitor can be powered on or off using the following three options:

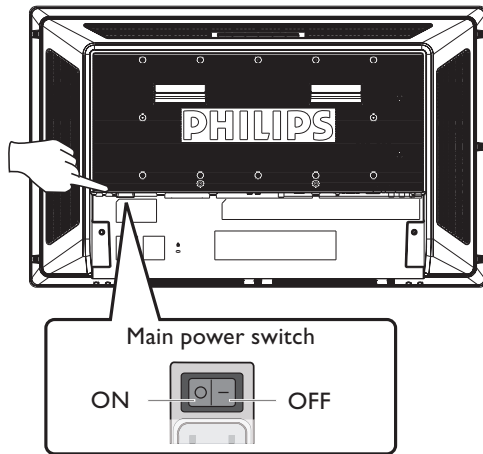

### 1. Pressing the Main Power Switch.

When the Main Power Switch is turned off, the LCD monitor, the remote control, the power button and the indicator will not work. Make sure to turn the Main Power Switch on before using the other two options.

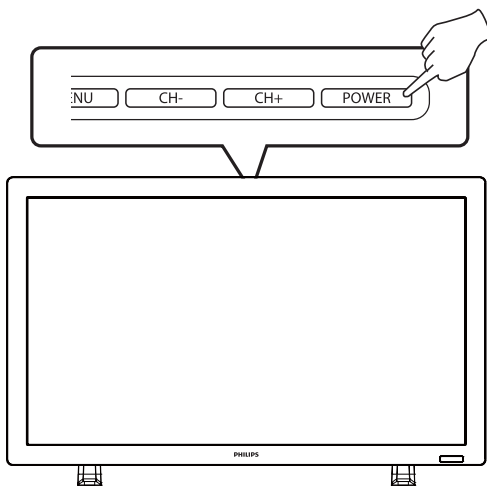

### 2. Pressing the power button.

Before pressing the power button, be sure to turn on the Main Power Switch on the LCD monitor.

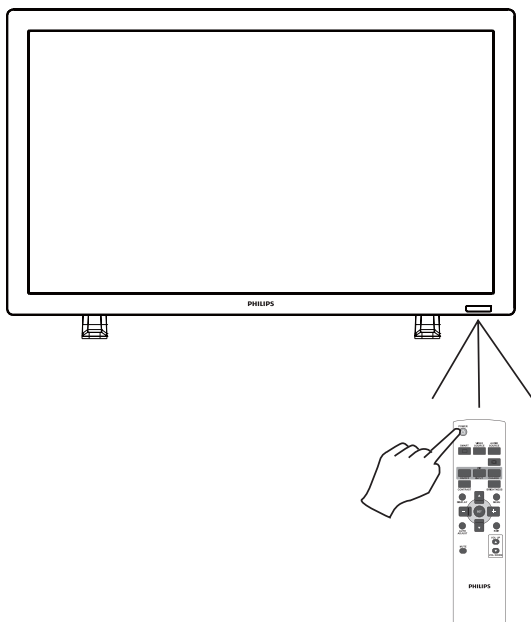

### 3. Using the remote control.

Before operating the remote control, be sure to turn on the Main Power Switch on the LCD monitor.

## Power Indicator

LED Status	Power Status	LED behavior
LED active	Normal on	Blue
	Standby	Amber
	RC command	Blue blinking
	RC / DC power off	Black
	AC power switch off	Black

## Using Power Management

The LCD monitor follows the VESA approved DPM Power Management function.

The power management function is an energy saving function that automatically reduces the power consumption of the display when the keyboard or the mouse has not been used for a certain period of time.

If the power management feature on the LCD monitor has been set to “ON” mode, this allows the system to enter a Power Saving Mode when no signal is applied. This could potentially increase the life time and decrease the power consumption of the LCD monitor.

## Display Signal of Video Source Setting to [VIDEO]

Use the input button on the front panel or the VIDEO SOURCE button on the remote control to set video source to [VIDEO].

Use the COLOR SYSTEM OSD menu to select [AUTO], [NTSC], [PAL], [SECAM], [PAL60], [4.43NTSC], according to your video format.

## Picture Size

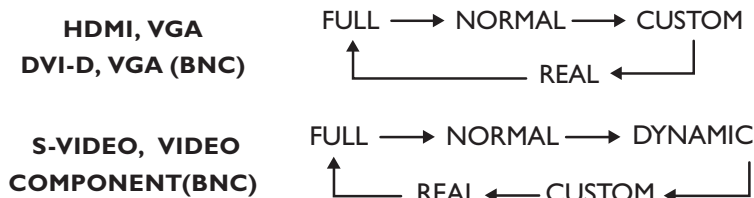

Signal Type	NORMAL SIZE	Recommended Size
4:3		NORMAL
		DYNAMIC
16:9		FULL

**NORMAL:** Display with the input signal aspect ratio from PC signal, or display in 4:3 aspect ratio at COMPONENT or VIDEO signal.

**FULL:** Display in the entire screen.

**DYNAMIC:** Expand 4:3 pictures to the entire screen with non-linearity.

**CUSTOM (ZOOM):** Images can be expanded beyond the active display area. The image which is outside of the active display area would not be shown.

**REAL:** Image will be displayed for one by one pixel.

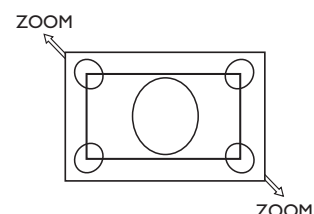

## Smart Picture Mode

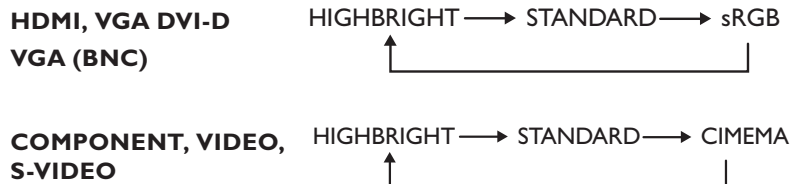

## Audio Source Switching

You can select audio source by using the AUDIO SOURCE button on the remote control.

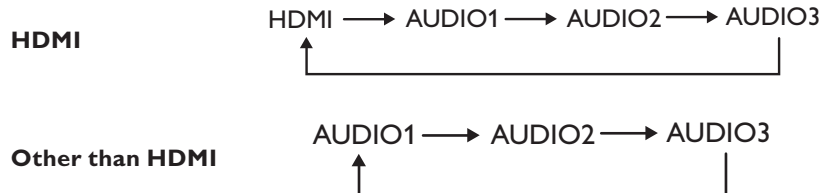

## Control Lock Mode

This function disables the operation of all local keyboard buttons on TV. When Control lock mode is activated, all adjustments via local keyboard buttons will not work.

To disable the buttons, press and hold down the **CH+** and **CH-** buttons together for at least 3 seconds.

To enable the buttons, press and hold down the **CH+** and **CH-** buttons together for at least 3 seconds again.

## OSD Information

### HDMI, VGA, VGA (BNC), DVI-D

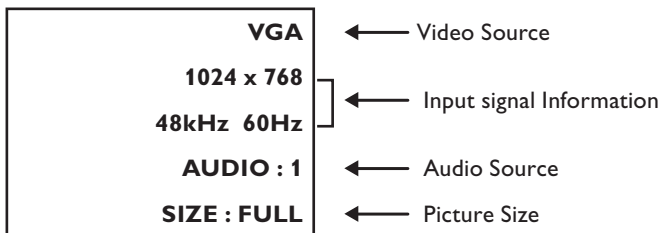

### COMPONENT



### S-VIDEO, VIDEO

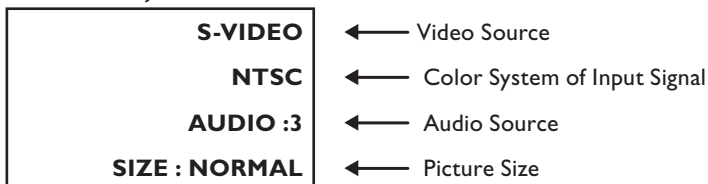

## PIP or POP

### Main: VGA / Sub: S-VIDEO

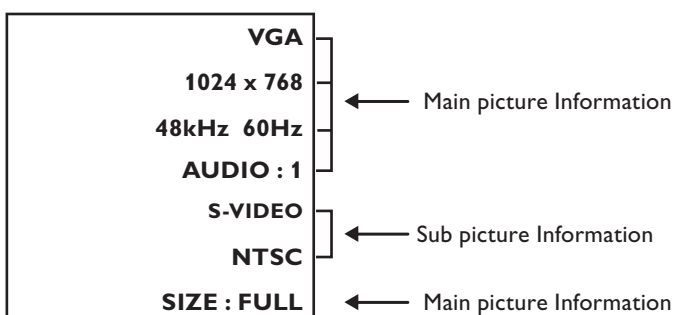

# OSD (On-Screen-Display) Controls

Press MENU button to open Main menu. Press ▲ or ▼ button to select the sub-menu

Press ▲ or ▼, and “+” or “-” button to make selection or adjust the setting. Press SET button to enable the setting.

Press MENU or EXIT button to exit.

Remote Control

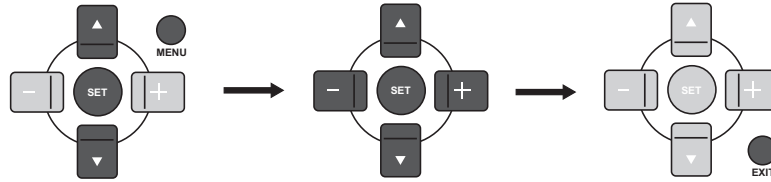

Press MENU button to open Main menu. Press CH + or CH - button to select.

Press CH + or CH - as ▲ or ▼ button, and VOL + or VOL - as ► or ◀ button to make selections or adjust the settings. Press VOL + as ► button to enable the setting.

Press MENU button to exit.

Control Panel

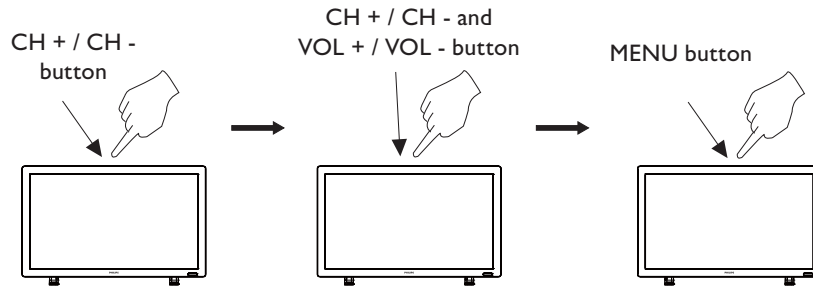

OSD screen

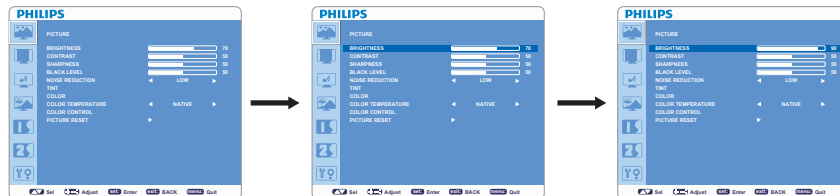

## Main-Menu

### PICTURE

#### ■ BRIGHTNESS

- Adjusts overall images and background screen brightness.
- Press + button to increase brightness.
- Press - button to decrease brightness.

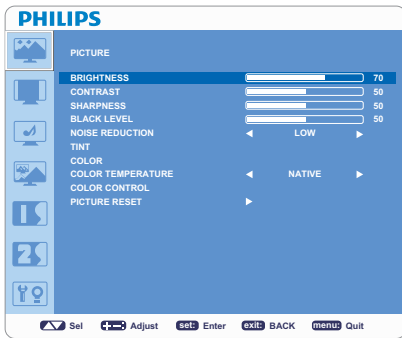

#### ■ CONTRAST

- Adjusts image brightness of the input signal.
- Press + button to increase contrast.
- Press - button to decrease contrast.

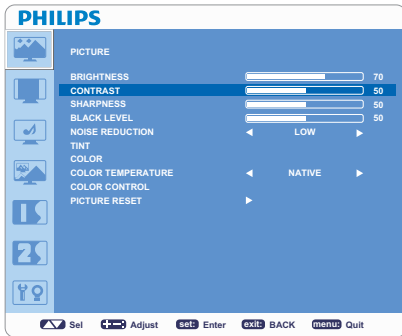

#### ■ SHARPNESS

- This function is digitally capable to keep a crisp image at any timing.
- It is adjustable to get a distinct or soft image.
- Each picture mode can be set independently.
- Press + button to increase sharpness.
- Press - button to decrease sharpness.

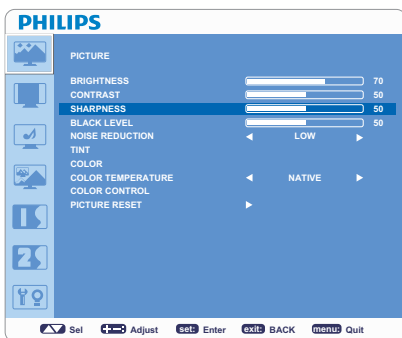

#### ■ BLACK LEVEL

- Adjusts image brightness for the background.
- Press + button to increase black level.
- Press - button to decrease black level.

**NOTE:** sRGB picture mode is the standard one and cannot be changed.

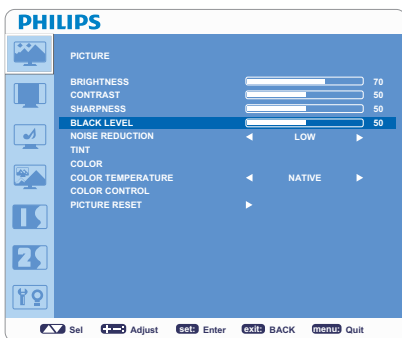

#### ■ NOISE REDUCTION

\* : INPUT S-VIDEO, VIDEO only

- Adjusts the noise reduction level.
- Press + button to increase noise reduction level.
- Press - button to decrease noise reduction level.

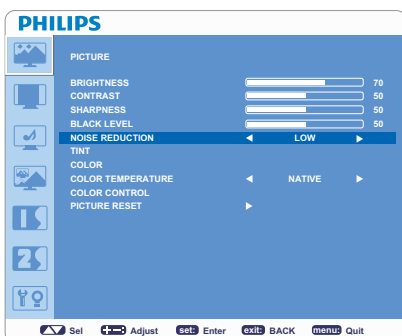

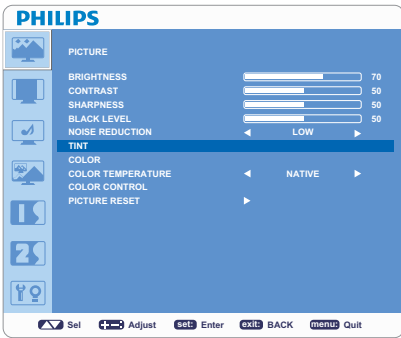

■ **TINT**

\* : INPUT HDMI (HDMI INPUT MODE-HD), COMPONENT, S-VIDEO, VIDEO only.

- Adjusts the color balance in an image.
- Press + button the flesh tone color becomes greenish.
- Press - button the flesh tone color becomes purplish.

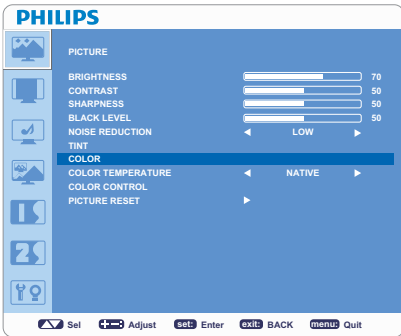

■ **COLOR**

\* : INPUT HDMI (HDMI INPUT MODE-HD), COMPONENT, S-VIDEO, VIDEO only.

- Adjusts the color saturation.
- Press + button to increase color depth.
- Press - button to decrease color depth.

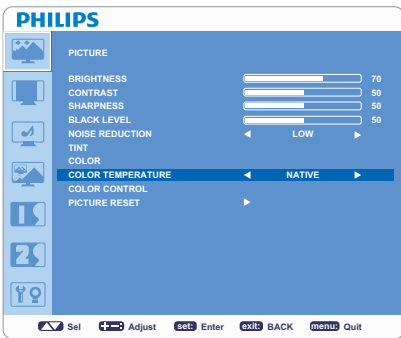

■ **COLOR TEMPERATURE**

- Adjust the color temperature.
- Color temperature can be set to values that match the application of the display.

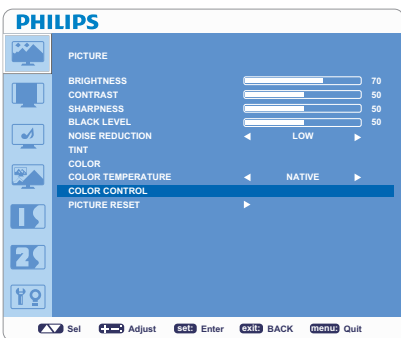

■ **COLOR CONTROL**

- The color level of red, green, and blue are adjustable by the color bars.
- R: Red, G: Green, B: Blue

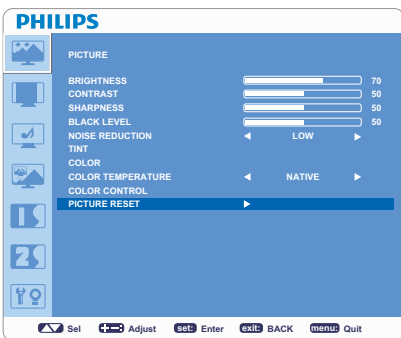

■ **PICTURE RESET**

- Selecting PICTUER RESET allows you to reset all OSD settings in “PICTURE” menu.
- Select “Yes” and press “SET” button to restore to factory preset data.
- Press “EXIT” button to cancel and then return to the previous menu.

## Main-Menu

### SCREEN

#### ■ H POSITION

\* : INPUT VGA and VGA(BNC) only.

- Controls the position of Horizontal Image within the LCD display area.
- Press + button to move image to right.
- Press - button to move image to left.

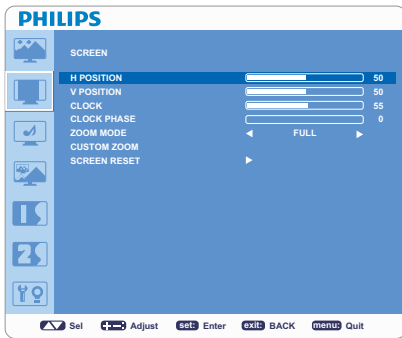

#### ■ V POSITION

\* : INPUT VGA and VGA(BNC) only.

- Controls the position of Vertical Image within the LCD display area.
- Press + button to move screen to UP.
- Press - button to move screen to DOWN.

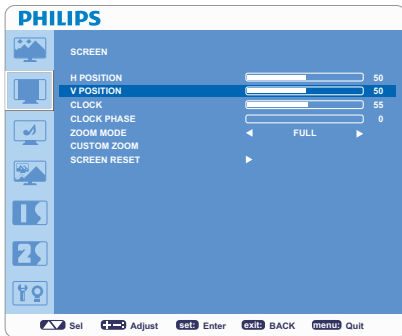

#### ■ CLOCK

\* : INPUT VGA, VGA(BNC) only.

- Press + button to expand the width of image to right on the screen.
- Press - button to narrow the width of the image to left on the screen.

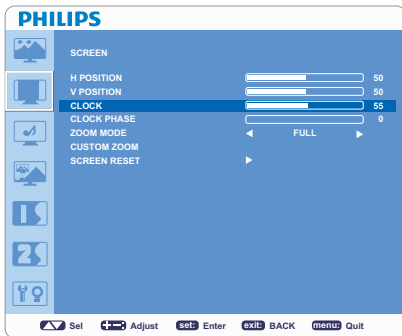

#### ■ CLOCK PHASE

\* : INPUT VGA, VGA(BNC) only.

Improves focus, clarity and image stability by increasing or decreasing this setting.

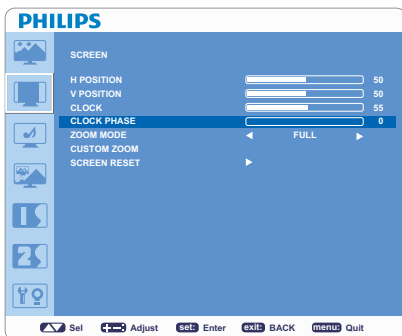

#### ■ ZOOM MODE

- Selects "FULL", "NORMAL", "CUSTOM" or "REAL". (INPUT HDMI, VGA, VGA(BNC) only.)
- Selects "FULL", "NORMAL", "DYNAMIC", "CUSTOM" or "REAL". (INPUT COMPONENT, S-VIDEO, VIDEO only)
- Dynamic image is the same as FULL size image when HDTV signal is the input source.
- Selecting "REAL" image will display 1 by 1 pixel.

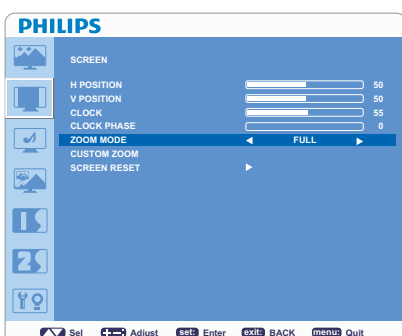

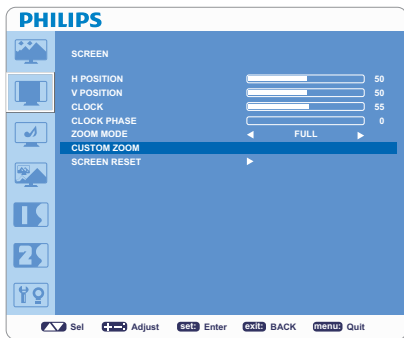

## ■ CUSTOM ZOOM

- “CUSTOM ZOOM” will be selected when you select “CUSTOM” in ZOOM MODE menu.
- “ZOOM”: expands horizontal and vertical size simultaneously.
- “HZOOM”: expands the horizontal size only.
- “VZOOM”: expands the vertical size only.
- “H POSITION”: moves to the right with + button and moves to the left with – button.
- “V POSITION”: moves up with + button and moves down with – button.

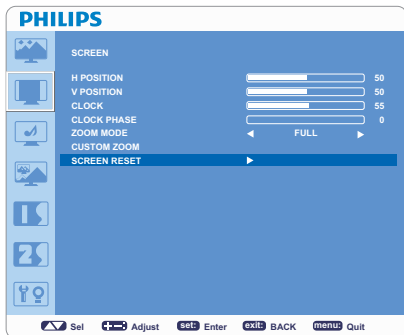

## ■ SCREEN RESET

- Select SCREEN RESET allows you to reset all OSD settings from “PICTURE” setting.
- Select “Yes” and press “SET” button to restore the factory preset data.
- Press “EXIT” button to cancel and then return to the previous menu.



## Main-Menu

### AUDIO

#### ■ BALANCE

- Adjusts the balance of L/R volume.
- Press + button to move the stereo sound image to right. Sound at the left side will be in low level.
- Press - button to move the stereo sound image to left. Sound at the right side will be in low level.

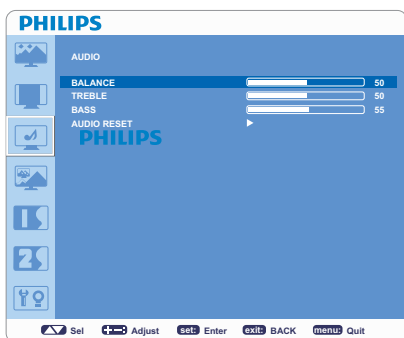

#### ■ TREBLE

- To accentuate or reduce the high frequency sound.
- Press + button to increase TREBLE sound.
- Press - button to decrease TREBLE sound.

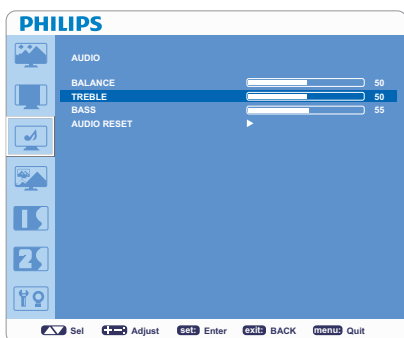

#### ■ BASS

- To accentuate or reduce the low frequency sound.
- Press + button to increase BASS sound.
- Press - button to decrease BASS sound.

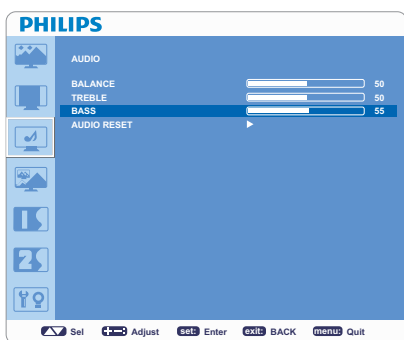

#### ■ AUDIO RESET

- Selecting Audio reset allows you to reset all OSD settings from "AUDIO" setting.
- Select "YES" and press "SET" button to restore the factory preset.
- Press "EXIT" button to cancel and then return to the previous menu.

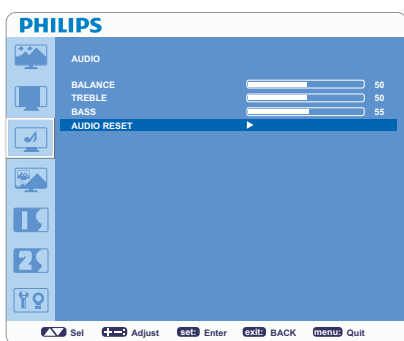

## Main-Menu

### PIP (PICTURE IN PICTURE)

#### NOTE:

The “PIP” and “POP” modes do not function when the screen size is set to “CUSTOM” or “REAL”.

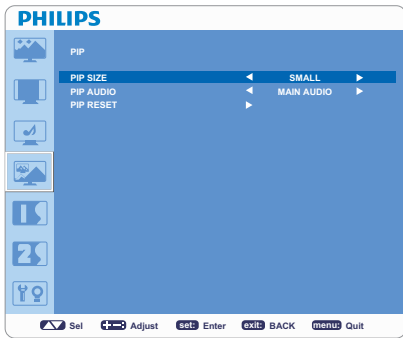

#### ■ PIP SIZE

- Selects the size of auxiliary picture that inserted in the main picture when “Picture-in-Picture” (PIP) mode is activated.
- “Large”, “Middle” and “Small” are available.

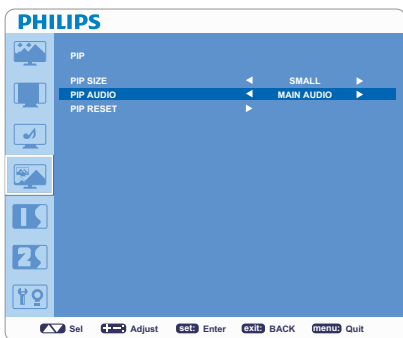

#### ■ PIP AUDIO

- Selects sound source in PIP mode.
- When “MAIN AUDIO” is selected, you will get the sound in the main picture, when “PIP AUDIO” is selected, you will get the sound in the auxiliary picture.

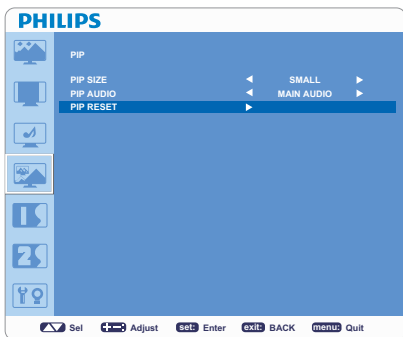

#### ■ PIP RESET

- Selecting PIP Reset allows you to reset all OSD settings from PIP setting.
- Select “Yes” and press “SET” button to restore the factory preset data.
- Press “EXIT” button to cancel and then return to the previous menu.

## Main-Menu

### CONFIGURATION I

#### ■ AUTO ADJUST

\* : INPUT VGA only

- Press “SET” button to automatically adjust screen size, horizontal position, vertical position, clock, clock phase, white level and black level.
- Press “EXIT” button to cancel the execution of “AUTO ADJUST” and return to the previous menu.

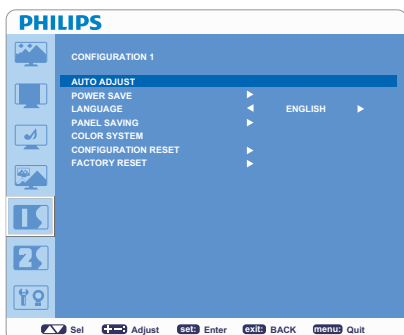

#### ■ POWER SAVE

- If VGA “ON” is selected, the monitor will go to power management mode when HDMI, VGA, VGA(BNC) and sync is lost.
- If VIDEO “ON” is selected, the monitor will go to power management mode after about 10 minutes delay from the time when COMPONENT, S-VIDEO or VIDEO input signal is lost.

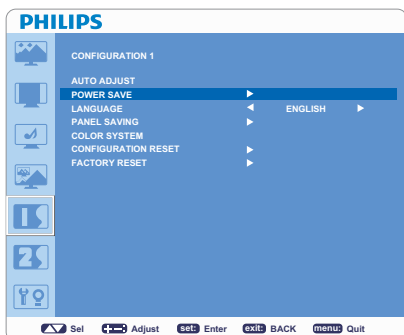

#### ■ LANGUAGE

OSD control menus are available in eight languages.

(English, German, French, Italian, Spanish, Polish, Turkish, Russian, Simple Chinese)

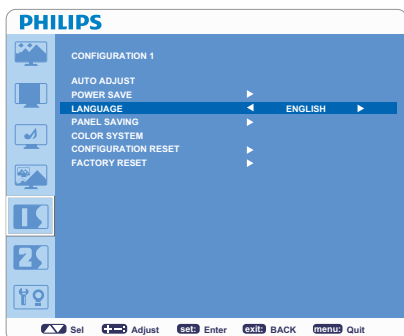

#### ■ PANEL SAVING

- Selects “PANEL SAVING” to reduce the risk of the “image persistence”.
- “BRIGHTNESS”: Selects “ON” to decrease brightness.
- “PIXEL SHIFT”: Image is slightly expanded periodically (Time setting for movement is required).
- Movement area is approximately +/- 10mm from original position.
- Please locate important information such as text within 90% area of the screen image.
- PIP will be disabled when “MOTION” is activated.

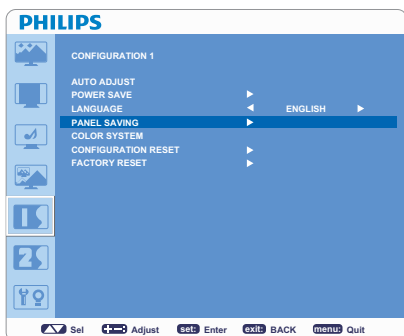

#### ■ COLOR SYSTEM

\* : INPUT S-VIDEO, VIDEO only

- Selects the Color System depends on your input video format.
- “AUTO”: NTSC, PAL, SECAM, PAL60 or 4.43 NTSC is automatically selected.
- “NTSC”: Specific selection of NTSC.
- “PAL”: Specific selection of PAL.
- “SECAM”: Specific selection of SECAM.
- “PAL-60”: Specific selection of PAL60.
- “4.43NTSC”: Specific selection of 4.43 NTSC.

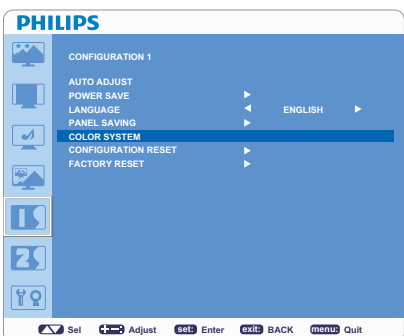

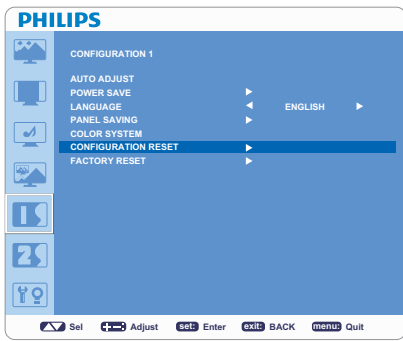

## ■ CONFIGURATION RESET

- Selecting “CONFIGURATION RESET” allows you to reset all configuration settings.
- Select “Yes” and press “SET” button to restore the factory preset data.
- Press “EXIT” button to cancel and return the previous menu.

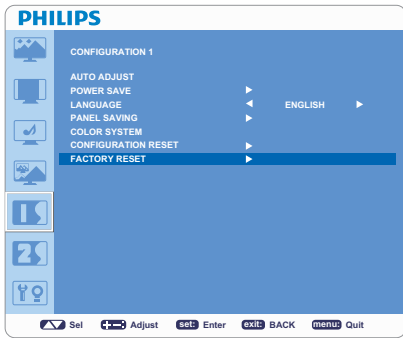

## ■ FACTORY RESET

- Selecting “YES” allows you to reset “PICTURE”, “SCREEN”, “AUDIO”, “CONFIGURATION 1”, “CONFIGURATION 2” and “ADVANCED OPTION” back to factory settings (except “LANGUAGE”, “DATE AND TIME” and “SCHEDULE”).
- Select “YES” and press “SET” button to restore the factory preset data.
- Press “EXIT” button to cancel and return the previous menu.

## Main-Menu

### CONFIGURATION 2

#### ■ OSD TURN OFF

- OSD control menu will stay on as long as it is activated. In the OSD Turn Off submenu, you can select how long the monitor waits after the last touch of a button to shut off the OSD control menu.
- The preset choices are 5 -120 seconds.

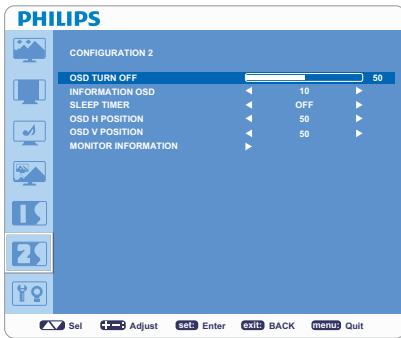

#### ■ INFORMATION OSD

- Sets the display of OSD information.
- The information OSD will display when input signal or source change or warning message like as no-signal or out-of range.
- A time bar between 1 to 10 seconds is available.

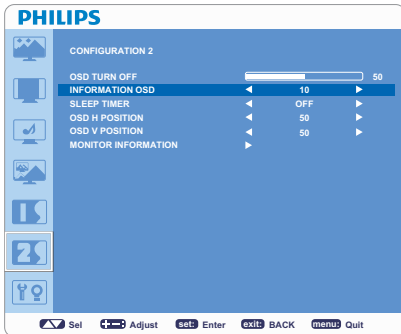

#### ■ SLEEP TIMER

- Sets "SLEEP TIMER" mode ON/OFF.
- In "SLEEP TIMER" menu, you can preset the monitor to automatically power off.
- A time bar between 1 to 24 hours is available.

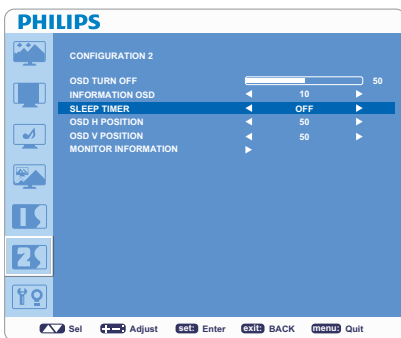

#### ■ OSD H POSITION

Adjusts the horizontal position of the OSD menu.

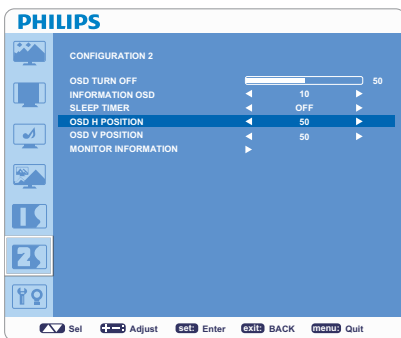

#### ■ OSD V POSITION

Adjusts the vertical position of the OSD menu.

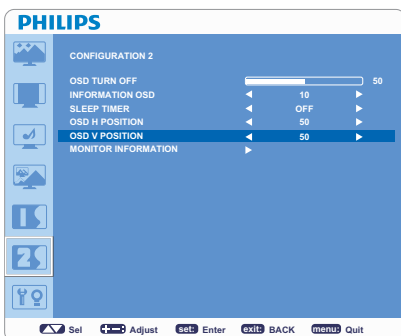

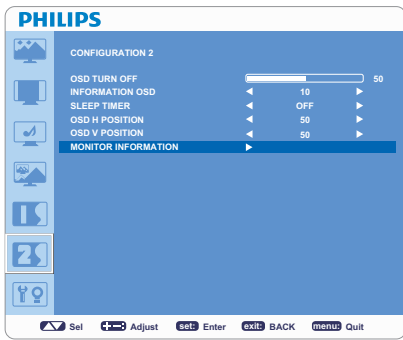

## ■ MONITOR INFORMATION

Indicates the model and serial number of your monitor.

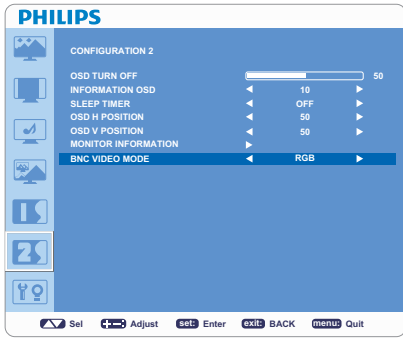

## ■ BNC VIDEO MODE

Selects between analog RGB component video (VGA) and analog Y Pb Pr component video.

## Main-Menu

### ADVANCED OPTION

#### ■ INPUT RESOLUTION

\* : INPUT VGA only

- Manually selects the correct timing according to the input source.
- “Auto” / “1024x768” / “1280x768” / “1360x768” / “1366 x 768”.

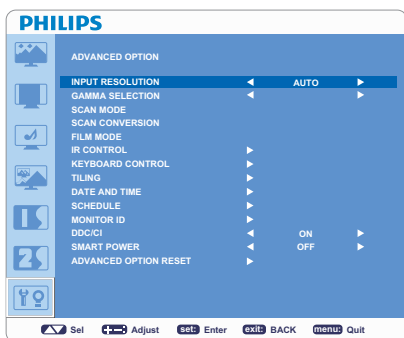

#### ■ GAMMA SELECTION

- Changes the displayed color temperature.
- “2.2” / “2.4” / “Native”

**NOTE:** sRGB picture mode is standard and cannot be changed.

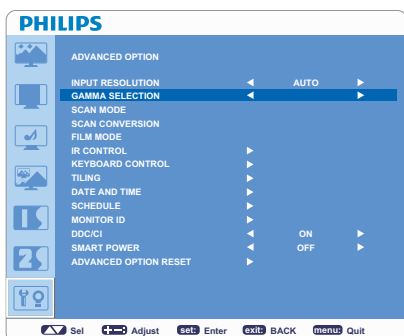

#### ■ SCAN MODE

\* : INPUT HDMI (HDMI INPUT MODE-HD), COMPONENT, S-VIDEO, VIDEO only

- Changes the display area of the image.
- “OVERSCAN”: Sets to display area about 95%.
- “UNDERSCAN”: Sets to display area about 100%.

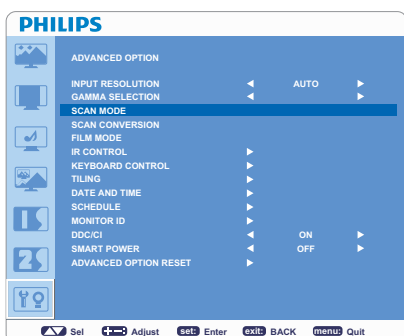

#### ■ SCAN CONVERSION

\* : INPUT HDMI (HDMI INPUT MODE-HD), COMPONENT, S-VIDEO, VIDEO only

- Selects IP (Interlace to Progressive) converter function.
- “PROGRESSIVE”: Enables the IP function, to convert interlace signal to progressive. Normally use this setting.
- “INTERLACE”: Disable the IP function.

**NOTE:** This mode is better suited for motion pictures, but it might cause the problem of image retention.

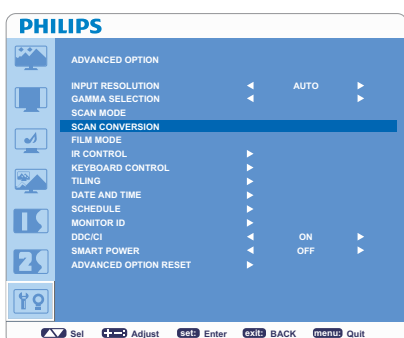

#### ■ FILM MODE

\* : INPUT HDMI (HDMI INPUT MODE-HD), COMPONENT, S-VIDEO, VIDEO only

- Selects Film mode function.
- “AUTO”: Enables the Film mode function. This mode is better suited for movies, which is converted 24 frames/sec source to DVD Video. We recommend to select “PROGRESSIVE” in “SCAN CONVERSION”.
- “OFF”: This mode is better suited for a broadcast source (like a set-top box) or VCRs.

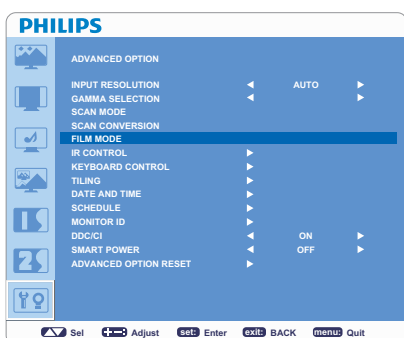

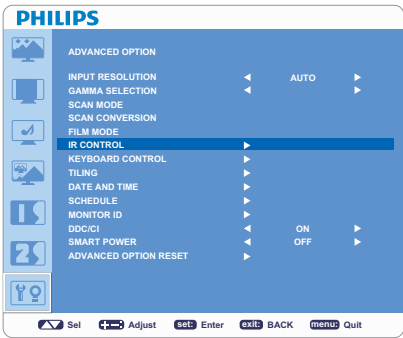

### ■ IR CONTROL

- Selects the operation mode of the remote controller when multiple BDL3215E/BDL4225E monitors are connected via RS-232C.
- The item in this menu will be effective by pressing “SET” button on the selected item.
- “NORMAL”: The monitor will be controlled normally by the remote controller.
- “PRIMARY”: The first BDL3215E/BDL4225E monitor of those multi-connected via RS-232C is designated as “PRIMARY”.
- “SECONDARY”: BDL3215E/BDL4225E monitors other than the first one multi-connected via RS-232C are designated as “SECONDARY”.
- “LOCK”: Disable the monitor control by infrared remote controller.
- Keep pressing “DISPLAY” button for 5 sec or more, this setting will return to “NORMAL”.

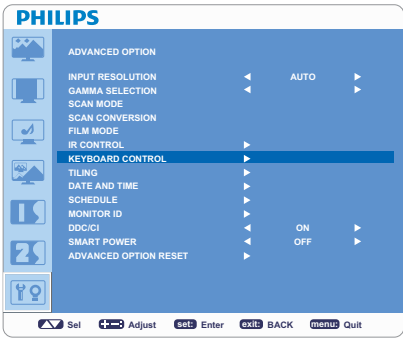

### ■ KEYBOARD CONTROL

- Selects the operation mode of the keyboard control.
- Select “YES” to disable the function of keyboard.
- Select “NO” to enable the function of keyboard.

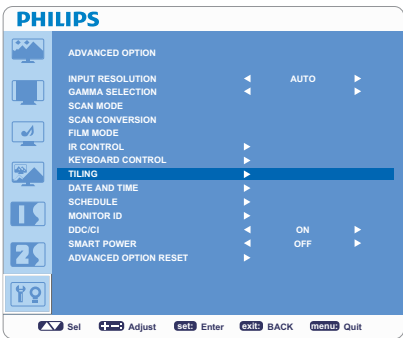

### ■ TILING

- “TILING” demonstrates multiple screens. This feature provides a single large screen using up to 25 monitors.
- It will be able to divide up to 5 each horizontal and vertical.
- This requires you to feed the PC output into each of the monitor through a distributor.
- “H MONITORS”: Selects the number of horizontal divide.
- “V MONITORS”: Selects the number of vertical divide.
- “POSITION”: Selects the position to expand the screen.
- “FRAME COMP”: Works in tandem with “TILING” to compensate for the width of the tile bezels in order to accurately display the image.
- “ENABLE”: Selects “YES”, the monitor will expand the selected position.
- PIP will be disabled when “TILING” is activate

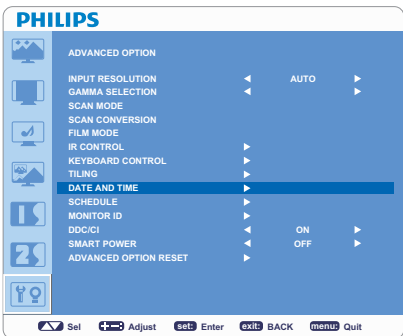

### ■ DATE AND TIME

- Adjusts the current date and time for internal clock. “SCHEDULE”.

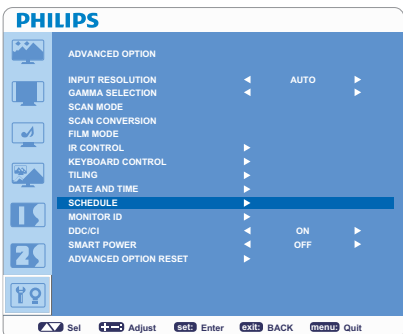

### ■ SCHEDULE

- Before using “SCHEDULE”, set current time and date for internal clock in “DATE AND TIME” menu.
- Programs the monitor’s working schedule.
- Schedule the power on / off time of the input source.
- “SCHEDULE” OSD will not disappear except pressing “EXIT” on the remote control.



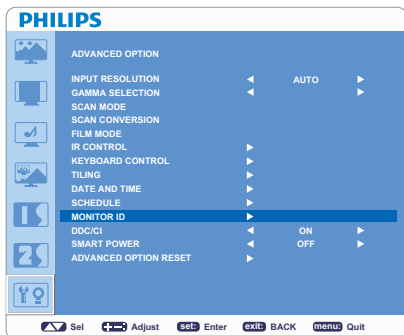

## ■ MONITOR ID

- ID numbers for remote control are assigned to BDL3215E/BDL4225E monitors that are multi-connected via RS-232C.
- ID numbers 1 to 26 are selectable.

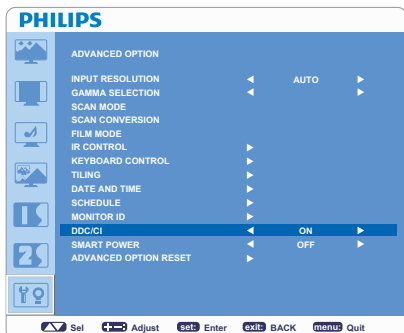

## ■ DDC/CI

Turns “ON” or “OFF” the DDC/CI communication function. Selects “ON” for normal use.

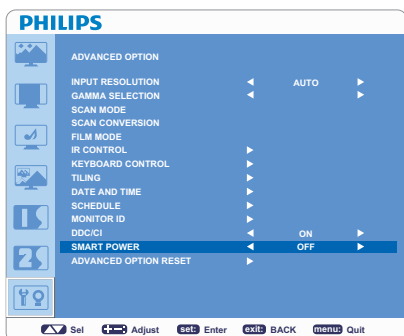

## ■ SMART POWER

- Selecting “SMART POWER” allows you to choose a certain level of power saving condition.
- Selects “OFF” to set the system in normal power condition.
- Selects “MEDIUM” to set the system in medium level power saving status.
- Selects “HIGH” to set the system in high level power saving status.
- Press “EXIT” button to cancel and return to the previous menu.

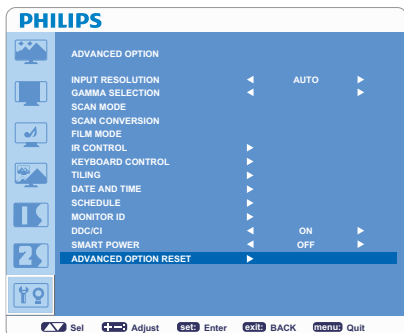

## ■ ADVANCED OPTION RESET

- Selecting “ADVANCED OPTION RESET” allows you to reset all OSD settings from “ADVANCED OPTION” menu, except for GAMMA SELECTION, “DATE AND TIME”, “SCHEDULE, MONITOR ID”, and “DDC/CI”.
- Selects “YES” and press “SET” button to restore the factory preset data.
- Press “EXIT” button to cancel and return the previous menu.
- “GAMMA SELECTION” is reset when “PICTURE RESET” in “PICTURE” menu is carried out.

## NOTE

### NOTE 1:

#### Image Persistence

- Please be aware that LCD Technology may experience a phenomena known as Image Persistence. Image Persistence occurs when residual or “ghost” image of the previous image remains visible on the screen. Unlike CRT monitors, LCD monitors’ image persistence is not permanent, but constant images being displayed for a long period of time should be avoided.
- To alleviate image persistence, turn off the monitor for as long as the previous image was displayed. For example, if an image was on the monitor for one hour and a residual image remains, the monitor should be turned off for one hour to erase the image.
- As with all personal display devices, PHILIPS recommends to display moving images and using a moving panel saving at regular intervals whenever the screen is idle or the monitor is turned off when not in use.
- Please set “POWER SAVE”, “PANEL SAVING”, “DATE AND TIME” and “SCHEDULE” functions to further reduce the risk of Image persistence.

#### Image Sticking of LCD Panel

Image Persistence is not permanent, but when fixed image is displayed for long period, ionic impurities inside LCD are accumulated along the displayed image, and it is observed permanently.

#### Recommendations

For preventing the fast transition to Image Sticking, and for longer life usage of LCD, the following are recommended.

1. Do not fixed image to be displayed for a long period of time on screen.
2. In case a fixed image is displayed for a long time, it is advised to activate the pixel shift feature that will periodically move the image in four directions
3. When the LCD monitor will not be used for a period of time, turns off the monitor by remote control, uses Power Management Function or uses “SCHEDULE” function from the monitor menu.
4. Reducing the environmental temperature is effective for long life use.  
When Protection board (glass, acryl) is installed over the LCD surface, enclosed into the box / wall, or stack the monitor, please utilize the temperature sensors inside monitor.
5. Accesses “PANEL SAVING” menu and set “BRIGHTNESS” to “ON”.

### NOTE 2:

#### HOW TO SETUP SCHEDULE

- Using “SCHEDULE” function allows you to set up to seven different scheduled time intervals when the LCD Monitor will be activated.
- Schedule the power on / off time of the input source. A check mark in the box next to the number of the schedule indicates that the selected schedule is in effect.
- Press ▲ or ▼ button to move the number (1 to 7) of the schedule to make the selection.
- Press (+) or (-) button to move the cursor horizontally within the particular schedule. Press ▲ or ▼ button to increase time and select input spot. The “SET” button is used to confirm a selection.
- If you create a schedule, but do not want to use the power on time, select “--” in the “ON” time slot.
- If you do not want to use the power off time, select “--” in the OFF time slot.
- If there is no input selected (“--” showing in the input spot), the input from the previous schedule will be used.
- The selection of EVERY DAY within a schedule takes priority over other schedules that are set up to operate weekly. When schedules are overlapping, scheduled Power ON time has priority over scheduled Power OFF time.
- If there are two schedules programmed for the same time, then the earliest / highest numbered scheduled has priority.

**NOTE 3: “PIP”, “POP” and “SIDE BY SIDE”**

The following table shows the combination of signal inputs under “PIP” and “POP” modes are activated. These modes do not function when the screen size is “CUSTOM” or “REAL”.

		SUB						
		HDMI	DVI-D	VGA	COMPONENT	S-VIDEO	VIDEO	VGA(BNC)
MAIN	HDMI	×	×	○	○	○	○	○
	DVI-D	×	×	○	○	○	○	○
	VGA	○	○	×	○	○	○	○
	COMPONENT	○	○	○	×	○	○	×
	S-VIDEO	○	○	○	○	×	×	○
	VIDEO	○	○	○	○	×	×	○
	VGA (BNC)	○	○	×	×	○	○	×

○: Supported

×: Not supported

Press the “PIP ON/OFF” buttons on the remote control to change between “PIP”, “POP” and “SIDE BY SIDE” mode as shown in the diagram below.

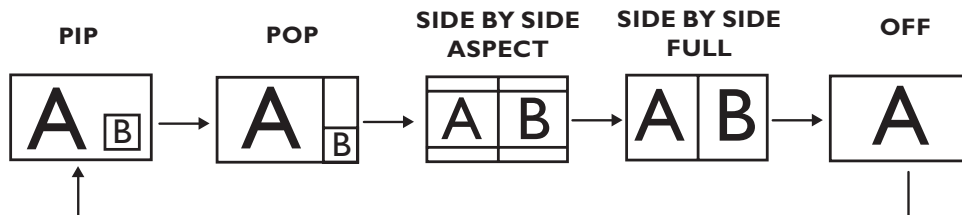

“PIP”, “POP” mode resolution (Reference)

PIP SIZE	◀	SMALL	▶	: 320 dots X 240 dots
	◀	MIDDLE	▶	: 480 dots X 320 dots
	◀	LARGE	▶	: 640 dots X 480 dots
POP SIZE				: 320 dots X 240 dots

**< Remote control numbering function >**

By connecting multiple BDL3215E/BDL4225E monitors by using RS-232C cables, you can control any or all monitors by one remote control.

- Assign arbitrary ID number to each of multi-connected BDL3215E/BDL4225E monitors by using MONITOR ID. ID numbers 1 to 26 are selectable.  
It is recommended to assign sequential ID numbers from 1 and up.
- The remote control mode of the first BDL3215E/BDL4225E monitor is set to PRIMARY and the other monitors are set to SECONDARY.
- When you direct the remote control at the remote control signal sensor of the PRIMARY monitor and press the DISPLAY button on the remote controller, the ID selection OSD appears at the upper left of the screen.

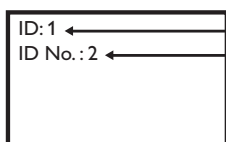

ID number of the currently viewed monitor

Select the ID number of the monitor you want to control using the +/- button on the remote controller. The ID of the monitor you want to control is displayed at the upper left of its screen. By selecting ALL, you can control all the multi-connected monitors.

- Direct the remote control at the remote control signal sensor of the PRIMARY monitor. OSD appears on the monitor will have the ID number you selected.

**NOTE:**

When the ID selection OSD is being displayed on the PRIMARY monitor, press the DISPLAY button on the remote controller again to cancel the ID selection OSD and then control the monitor you selected.

**HINT:**

If you set the remote control mode wrongly and remote control operation becomes unavailable, press MENU button on the control panel of the monitor to display the OSD screen and change the remote control mode using ADVANCED OPTION. By pressing and holding down the DISPLAY button on the remote control for 5 seconds or longer, the remote control mode is initialized to NORMAL.

## Pixel defect policy

Philips strives to deliver the highest quality products. We use some of the industry’s most advanced manufacturing processes and practice stringent quality control. However, pixel or sub-pixel defects on the PDP / TFT panels used in Plasma- & LCD- displays are sometimes unavoidable. No manufacturer can guarantee that all panels will be free from pixel defects, but Philips guarantees that any Plasma- & LCD- displays with an unacceptable number of defects will be repaired during the warranty period in line with your local guarantee conditions. This notice explains the different types of pixel defects and defines the acceptable defect level for the BDL3215E/BDL4225E LCD screen. In order to qualify for repair under warranty, the number of pixel defects must exceed a certain level which is given in the reference table. If the LCD screen is within specification a warranty exchange / claim back will be refused. Additionally, because some types or combinations of pixel defects are more noticeable than others, Philips sets even higher quality standards for those.

### Pixels and Sub-pixels

A pixel, or picture element, is composed of three sub-pixels in the primary colors of red, green and blue. Many pixels together form an image. When all sub-pixels of a pixel are lit, the three colored sub-pixels together appear as a single white pixel. When all are dark, the three colored sub-pixels together appear as a single black pixel. Other combinations of lit and dark sub-pixels appear as single pixels of other colors.

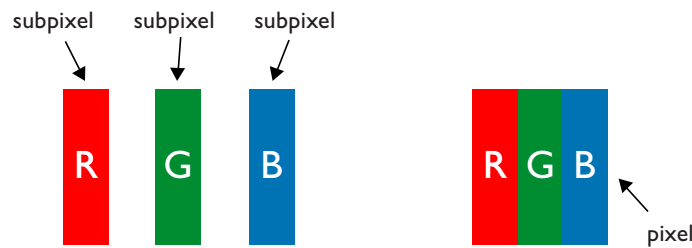

### Types of Pixel Defects + Dot definition

Pixel and sub-pixel defects appear on the screen in different ways. There are three categories of pixel defects and several types of sub-pixel defects within each category.

#### **Dot definition = What is a defective “Dot”? :**

One or more defective, adjacent sub-pixel are defined as one “dot”. The no. of defective sub-pixels are not relevant to define a defective dot. This means that a defective dot can consist of one, two or three defective sub-pixels which can be dark or lit.



One dot = One Pixel; consists of three sub-pixels of Red; Green and Blue

#### **Bright Dot Defects**

Bright dot defects appear as pixels or sub-pixels that are always lit or “on”. These are the examples of bright dot defects:

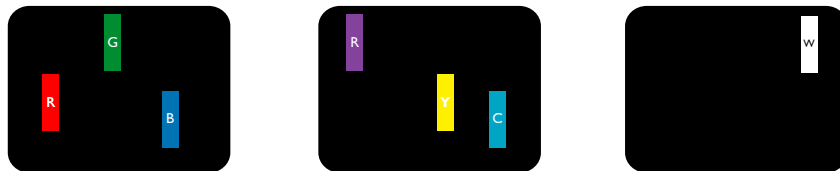

One lit red, green or blue sub-pixel	Two adjacent lit sub-pixels: - Red + Blue = Purple - Red + Green = Yellow - Green + Blue = Cyan (Light Blue)	Three adjacent lit sub-pixels (one white dot)
--------------------------------------	---	---

## Dark Dot Defects

Black dot defects appear as pixels or sub-pixels that are always dark or “off”. These are the examples of black dot defects:

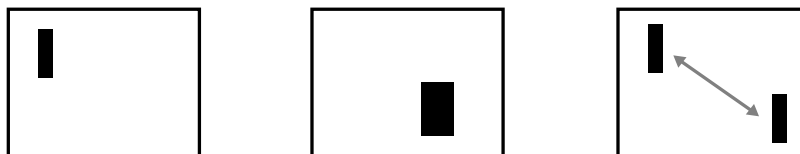

One dark dot	Two adjacent dark dots= 1 pair of dark dots	Two dark dots, specifica- tions defines the minimum distance between dark dots
--------------	--	--

## Proximity of Pixel Defects

Because pixel and sub-pixels defects of the same type that are nearby one another may be more noticeable, Philips also specifies tolerances for the proximity of pixel defects. In the table below you can find specifications about:

- Allowed amount of adjacent dark dots = (adjacent dark dots =1 pair of dark dots)
- Minimum distance between dark dots
- Total no. of all defective dots

## Pixel Defect Tolerances

In order to qualify for repair due to pixel defects during the warranty period, a PDP / TFT panel in a Philips Plasma / LCD- display must have pixel or sub-pixel defects exceeding the tolerances listed in the following table.

BRIGHT DOT EFFECT		ACCEPTABLE LEVEL	
MODEL	BDL3215E	BDL4225E	
1 lit sub pixel	3	1	
2 adjacent lit sub pixels	1	1	
3 adjacent lit sub pixels (one white pixel)	0	0	
50% ~ Less Dot (Weak Dot)	7	7	
Distance between two bright dot defects*	5mm	5mm	
Total bright dot defects of all types	7	7	
BLACK DOT EFFECT		ACCEPTABLE LEVEL	
1 dark sub pixel	9	8	
2 adjacent dark sub pixels	3	3	
3 adjacent dark sub pixels	1	1	
Distance between two black dot defects*	NA	NA	
Total black dot defects of all types	9	8	
<b>TOTAL DOT DEFECTS OF ALL TYPES</b>	<b>10</b>	<b>9</b>	

### NOTE:

\* 1 or 2 adjacent sub pixel defects = 1 dot defect.

# Troubleshooting

## No picture

- The signal cable should be completely connected to the display card/computer.
- The display card should be completely seated in its slot.
- Power Switch and computer power switch should be in set to “ON”.
- Check and make sure the display card is in supported mode or system is being activated. (Please refer to display card or system manual to change graphics mode.)
- Check the monitor and your display card with respect to compatibility and recommended settings.
- Check the signal cable connector for bent or pushed-in pins.
- If nothing is displayed on the screen when HDCP device is connected, reset the power of the device.

## Power Button does not respond

- Unplug the power cord of the monitor from the AC outlet to turn off and reset the monitor.

## Image persistence / Advanced anti image sticking

- As with all personal display devices, PHILIPS recommends to display moving images and using a moving panel saving at regular intervals whenever the screen is idle or the monitor is turned off when not in use.
- Do not allow a still image to be displayed for an extended period of time as this can cause a permanent after-image to remain on the monitor.

## Image is unstable or unfocused

- Signal cable should be completely attached to the computer.
- Use the OSD Image Adjust controls to focus and adjust display by increasing or decreasing the fine adjustment. When the display mode is changed, the OSD Image Adjust settings may need to be re-adjusted.
- Check the monitor and your display card with respect to compatibility and recommended signal timings.
- If your text is garbled, change the video mode to non-interlace and use 60 Hz refresh rate.

## Image of component signal is greenish

- Check to see if the COMPONENT input connector is selected.

## LED on monitor is not lit (no blue or amber color can be seen)

- Power Switch should be in the ON position and power cord should be connected.
- Make certain the computer is not in a power-saving mode (touch the keyboard or mouse).

## Display image is not sized properly

- Use the OSD Image Adjust controls to increase or decrease the coarse adjustment.
- Check and make sure the display card is in supported mode or system is being activated. (Please refer to display card or system manual to change graphics mode.)

## Selected resolution is not displayed properly

- Use OSD Display Mode to enter Information menu and confirm that the appropriate resolution has been selected. If not, select corresponding option.

## No Sound

- Check if mute function is activated.
- Check if volume is set at minimum.

## Remote Control doesn't work

- Check the Remote Control's batteries status.
- Check if batteries are inserted correctly.
- Check if the Remote Control is pointing at the monitor's remote sensor when operating.

---

**“SCHEDULE”/“SLEEP TIMER” function is not working properly**

- If “SCHEDULE” and “SLEEP TIMER” schedules are programmed at the same time, then the earliest / highest numbered schedule has priority.
- “SLEEP TIMER” will be reset by the following reasons:
  - If the “SLEEP TIMER” function is enable
  - If the LCD monitor power supply is interrupted unexpectedly.

**Stripe Noise**

- Light vertical or horizontal stripes may appear depending on the specific display pattern. This is no product fault or degradation.

**“NO SIGNAL” is displayed on the screen**

- Image may not be displayed right after HDCP device is connected.

# Specifications

## Product Specifications (BDL3215E)

<b>LCD Module</b>	Diagonal:	32" / 80 cm diagonal	
	Pixel Pitch:	0.511 mm / 0.51075(H)x0.51075(V)	
	Resolution:	1366 x 768 dots	
	Color:	Over 16 million colors (depending on video card used)	
	Display Colors:	8bit-16.7M	
	Brightness:	450 cd/m <sup>2</sup> (typ.)	
	Contrast Ratio:	3500:1 (typ.)	
	Response time:	8ms (typ.)	
Viewing Angle:	89° (typ.) @ CR>10		
Design View Distance:	875 mm		
<b>Frequency</b>	Horizontal:	15.625 / 15.734, 31.5 - 91.1 kHz	
	Vertical:	50.0 / 58.0 - 85.0 Hz	
<b>Pixel Clock</b>	25.0 MHz - 165.0 MHz		
<b>Viewable Size</b>	697.7 mm x 392.3 mm		
<b>Input Signal</b>			
HDMI	HDMI 19 Pin	Digital	Digital TMDS (with HDCP)
DVI-D	DVI-D 24 Pin	Digital RGB	DVI (HDCP) VGA60, SVGA60, XGA60, WXGA, SXGA60*1, UXGA*1, 1920 x 1080*1 (60Hz)
VGA	15pin Mini D-sub	Analog RGB	0.7 Vp-p/75 ohm VGA60, SVGA60, XGA60, WXGA, SXGA60*1, UXGA*1, 1920 x 1080*1 (60Hz)
		Sync	Separate: T TL level (Pos./Neg)
VGA(BNC)	BNC (R,G,B,H,V)	Analog RGB	0.7 Vp-p/75ohm VGA60, SVGA60, XGA60, WXGA, SXGA60*1, UXGA*1, 1920 x 1080*1 (60Hz)
		Sync	Separate: TTL level (Pos./Neg)
COMPONENT	BNC (Y,Cb/Pb, Cr/Pr)	Component	Y: 1.0 Vp-p/75 ohm, Cb/Cr (Pb/Pr): 0.7 Vp-p/75 ohm HDTV/DVD:1080i@60Hz*1, 1080p@60Hz*1, 720p@50Hz/60Hz, 576p@50Hz, 480p@60Hz, 576i@50Hz, 480i@60Hz
S-VIDEO	Mini DIN 4 pin	S-VIDEO	Y: 1.0 Vp-p/75 ohm C: 0.286 Vp-p/75 ohm (NTSC), 0.3Vp-p/75 ohm (PAL/SECAM) NTSC/PAL/SECAM/4.43NTSC/PAL60
VIDEO	BNC RCA	Composite	1.0 Vp-p/75 ohm NTSC/PAL/SECAM/4.43NTSC/PAL60
<b>Output Signal</b>			
VGA	15pin Mini D-sub	Analog RGB	0.7 Vp-p with 75 ohm terminated. Separate HV sync: TTL level (Pos./Neg)
VIDEO	BNC	Composite	1.0 Vp-p with 75 ohm terminated
<b>AUDIO</b>			
AUDIO Input	RCA (L/R) x2 STEREO Mini Jack	Analog RGB	Stereo L/R 0.5 Vrms
AUDIO Output	RCA (L/R)	Analog RGB	Stereo L/R 0.5 Vrms
<b>Speaker</b>	Speaker Jack 7W + 7W (8 ohm)		
<b>Control</b>	RS-232C In:	9 Pin D-sub	
<b>Power Supply</b>	1.4 – 0.6 A @100 - 240 VAC, 50-60 Hz		
<b>Operational Environment</b>	Temperature:	5 - 40 °C (landscape), 5 - 35 °C (portrait)	
	Humidity:	20 - 80 % (without condensation)	
	Altitude:	0 – 3000 m	
<b>Storage Environment</b>	Temperature:	-20 - 60 °C	
	Humidity:	10 - 90% (without condensation)/90% - 3.5% x (Temp - 40°C) regarding over 40°C	
<b>Dimension</b>	Net:	789 (W) x 476.3 (H) x 133 (D) mm	
	Gross:	926 (W) x 610 (H) x 286 (D) mm	
<b>Weight (without stand)</b>	Net:	13.2 kg	
	Gross:	17.4 kg	



**Product Specifications (BDL3215E)**

<b>VESA Compatible arm mounting interface</b>	200 mm x 200 mm & 200 mm x 400 mm (10Holes)
<b>Complied Regulatory and Guidelines</b>	UL60950-1/CSA C22.2 No. 60950-1/TUV/GS/EN60950-1 FCC-B/DOC-B/EN55022-B/EN55024/EN61000-3-2/EN61000-3-3/CE/GOST-R
<b>Power Management</b>	VESA DPM
<b>Power consumption</b>	Normal on : 115W (typical), 120W (max.)
	Standby: < 1W, standby mode
	Switch off (DC or TACT): < 1W, RC active
	Switch off (AC mains): < No power consumption
<b>Plug &amp; Play</b>	VESA DDC2B, DDC/CI
<b>Accessories</b>	Setup Manual, Quick installation guide, Power Cord, Video Signal Cable, Remote Control, AAA Battery x 2, Screw for Main switch cover x 2, CD-ROM, Main switch cover.

**NOTE:** Technical specifications are subject to change without notice

\*I: Compressed image

**Product Specifications (BDL4225E)**

<b>LCD Module</b>	Diagonal:	42.02" / 106.731cm diagonal	
	Pixel Pitch:	0.4845 mm (H) x 0.4845 mm(V)	
	Resolution:	1920 x 1080 dots	
	Color:	Over 16 million colors (depending on video card used)	
	Display Colors:	10bit-1.06 Billion colors	
	Brightness:	500cd /m <sup>2</sup> (typ.)	
	Contrast Ratio:	1400:1 (typ.)	
	Response time:	5ms (typ.)	
	Viewing Angle:	89° (typ.) @ CR>10	
Design View Distance:	1300 mm		
<b>Frequency</b>	Horizontal:	15.625 / 15.734, 31.5 - 91.1 kHz	
	Vertical:	50.0 / 58.0 - 85.0 Hz	
<b>Pixel Clock</b>	25.0 MHz - 165.0 MHz		
<b>Viewable Size</b>	930.24 mm x 523.26 mm		
<b>Input Signal</b>			
HDMI	HDMI 19 Pin	Digital	Digital TMDS (with HDCP)
DVI-D	DVI-D 24 Pin	Digital RGB	DVI (HDCP) VGA60, SVGA60, XGA60, WXGA, SXGA60, UXGA*1, 1920 x 1080*1 (60Hz)
VGA	15pin Mini D-sub	Analog RGB	0.7 Vp-p/75 ohm VGA60, SVGA60, XGA60, WXGA, SXGA60, UXGA*1, 1920 x 1080*1 (60Hz)
		Sync	Separate: TTL level (Pos./Neg)
VGA(BNC)	BNC (R,G,B,H,V)	Analog RGB	0.7 Vp-p/75ohm VGA60, SVGA60, XGA60, WXGA, SXGA60, UXGA*1, 1920 x 1080*1 (60Hz)
		Sync	Separate: TTL level (Pos./Neg)
COMPONENT	BNC (Y,Cb/Pb, Cr/Pr)	Component	Y: 1.0 Vp-p/75 ohm, Cb/Cr (Pb/Pr): 0.7 Vp-p/75 ohm HDTV/DVD:1080i@60Hz, 1080p@60Hz, 720p@50Hz/60Hz, 576p@50Hz, 480p@60Hz, 576i@50Hz, 480i@60Hz
S-VIDEO	Mini DIN 4 pin	S-VIDEO	Y: 1.0 Vp-p/75 ohm C: 0.286 Vp-p/75 ohm (NTSC), 0.3Vp-p/75 ohm (PAL/SECAM) NTSC/PAL/SECAM/4.43NTSC/PAL60
VIDEO	BNC RCA	Composite	1.0 Vp-p/75 ohm NTSC/PAL/SECAM/4.43NTSC/PAL60
<b>Output Signal</b>			
VGA	15pin Mini D-sub	Analog RGB	0.7 Vp-p with 75 ohm terminated. Separate HV sync: TTL level (Pos./Neg)
VIDEO	BNC	Composite	1.0 Vp-p with 75 ohm terminated
<b>AUDIO</b>			
AUDIO Input	RCA (L/R) x2 STEREO Mini Jack	Analog RGB	Stereo L/R 0.5 Vrms
AUDIO Output	RCA (L/R)	Analog RGB	Stereo L/R 0.5 Vrms
<b>Speaker</b>	Speaker Jack 7W + 7W (8 ohm)		
<b>Control</b>	RS-232C In:	9 Pin D-sub	
<b>Power Supply</b>	3.0 – 1.0 A @100 - 240 VAC, 50-60 Hz		
<b>Operational Environ- ment</b>	Temperature:	5 - 40 °C (landscape), 5 - 35 °C (portrait)	
	Humidity:	20 - 80 % (without condensation)	
	Altitude:	0 – 3000 m	
<b>Storage Environment</b>	Temperature:	-20 - 60 °C	
	Humidity:	10 - 90% (without condensation)/90% - 3.5% x (Temp - 40°C) regarding over 40°C	
<b>Dimension</b>	Net:	1021.8(w) x 662.7(H) x 250(D) mm	
	Gross:	1170(w) x 748(H) x 341(D) mm	
<b>Weight (without stand)</b>	Net:	21.8 kg	
	Gross:	28 kg	
<b>VESA Compatible arm mounting interface</b>	200 mm x 200 mm & 200 mm x 400 mm (10Holes)		
<b>Complied Regulatory and Guidelines</b>	UL60950-1/CSA C22.2 No. 60950-1/TUV/GS/EN60950-1 FCC-B/DOC-B/EN55022-B/EN55024/EN61000-3-2/EN61000-3-3/CE/GOST-R		

**Product Specifications (BDL4225E)**

<b>Power Management</b>		VESA DPM
<b>Power consumption</b>	Normal on:	215W (typical), 220W (max.)
	Standby:	< 1W, standby mode
	Switch off (DC or TACT):	< 1W, RC active
	Switch off (AC mains):	< No power consumption
<b>Plug &amp; Play</b>		VESA DDC2B, DDC/CI
<b>Accessories</b>		Setup Manual, Quick installation guide, Power Cord, Video Signal Cable, Remote Control, AAA Battery x 2, Screw for Main switch cover x 2, CD-ROM, Main switch cover.

**NOTE:** Technical specifications are subject to change without notice

\*I: Compressed image

# Pin Assignment

## 1. Analog Video Signal Input (Mini D-SUB 15P): VGA

Pin No	Name
1	Video Signal Red
2	Video Signal Green
3	Video Signal Blue
4	GND
5	DDC-GND
6	Red - GND
7	Green - GND
8	Blue -GND
9	+5V (DDC)
10	SYNC-GND
11	GND
12	DDC-SDA
13	H-SYNC
14	V-SYNC
15	DDC-SCL

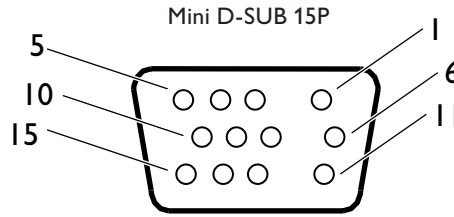

## 2. S-VIDEO input (MINI DIN 4P): S-VIDEO

Pin No	Name
1	GND
2	GND
3	Y (Luminance)
4	C (Chroma)

MINI DIN 4P

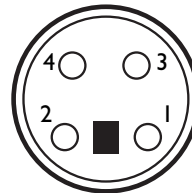

## 3. HDMI

Pin - Assignment of HDMI connector:					
1	TMDS Data2+	8	TMDS Data0 Shield	15	SCL
2	TMDS Data2 Shield	9	TMDS Data0-	16	SDA
3	TMDS Data2-	10	TMDS Clock+	17	DDC/CEC Ground
4	TMDS Data1+	11	TMDS Clock Shield	18	+5V Power
5	TMDS Data1 Shield	12	TMDS Clock	19	Hot Plug Detect
6	TMDS Data1-	13	CEC		
7	TMDS Data0+	14	Reserved (N.C. on device)		

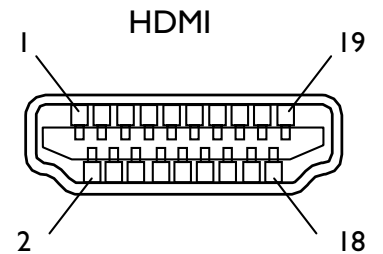

## 4. RS-232C input/output

Pin No	Name
1	NC
2	RXD
3	TXD
4	NC
5	GND
6	NC
7	RTS
8	CTS
9	NC

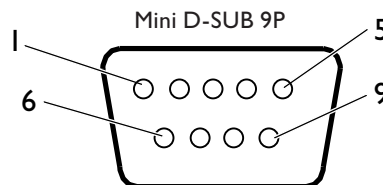



**2010 © Koninklijke Philips Electronics N.V. All rights reserved.  
Philips and the Philips Shield Emblem are registered trademarks  
of Koninklijke Philips Electronics N.V and are used under license  
from Koninklijke Philips Electronics N.V.  
Specifications are subject to change without notice.**

**[www.philips.com](http://www.philips.com)**