

***95Ce Upright Exercise Bike***  
operation manual



*LifeFitness*

## **CORPORATE HEADQUARTERS**

5100 North River Road  
Schiller Park, Illinois 60176 • U.S.A.  
847.288.3300 • FAX: 847.288.3703  
800.735.3867 (Toll-free within U.S.A., Canada)

[www.lifefitness.com](http://www.lifefitness.com)

## **INTERNATIONAL OFFICES**

### **LIFE FITNESS ASIA PACIFIC LTD**

Room 2610, Miramar Tower  
132 Nathan Road  
Tsimshatsui, Kowloon  
HONG KONG  
Telephone: (+852) 2891.6677  
FAX: (+852) 2575.6001

### **LIFE FITNESS ATLANTIC BV**

**LIFE FITNESS BENELUX**  
Bijdorpplein 25-31  
2992 LB Barendrecht  
THE NETHERLANDS  
Telephone: (+31) 180.646.666  
FAX: (+31) 180.646.699  
Telephone: (+32) 87.300.942  
FAX: (+32) 87.300.943

### **LIFE FITNESS DO BRAZIL**

Av. Dr. Dib Sauaia Neto 1478  
Alphaville, Barueri, SP  
06465-140  
BRAZIL  
Telephone (+55) 11.4193.8282  
FAX: (+55) 11.4193.8283

### **LIFE FITNESS VERTRIEBS GMBH**

Dückerstraße 7-9/3/36  
1220 Vienna  
AUSTRIA  
Telephone: (+43) 1.61 57 198  
FAX: (+43) 1.61 57 198.20

### **LIFE FITNESS IBERIA**

Pol. Ind. Molí dels Frares. c/C, nº 12  
08620 Sant Vicenç dels Horts (Barcelona)  
SPAIN  
Telephone: (+34) 93.672.4660  
FAX: (+34) 93.672.4670

### **LIFE FITNESS EUROPE GMBH**

Siemensstraße 3  
85716 Unterschleißheim  
GERMANY  
Telephone: (+49) 89.31 77 51.0  
FAX: (+49) 89.31 77 51.99

### **LIFE FITNESS ITALIA S.R.L.**

Via Vittorio Veneto, 57/A  
39042 Bressanone (Bolzano)  
ITALY  
Telephone: (+39) 0472.835 470  
FAX: (+39) 0472.833 150

### **LIFE FITNESS LATIN AMERICA and CARIBBEAN**

5100 North River Road  
Schiller Park, Illinois 60176  
U.S.A.  
Telephone: (+1) 847.288.3300  
FAX: (+1) 847.288.3886

### **LIFE FITNESS UK LTD**

Queen Adelaide  
Ely, Cambs CB7 4UB  
UNITED KINGDOM  
Telephone: (+44) 1353.666017  
FAX: (+44) 1353.666018

### **LIFE FITNESS JAPAN**

Nippon Brunswick Bldg., #8F  
5-27-7 Sendagaya  
Shibuya-Ku, Tokyo  
JAPAN 151-0051  
Telephone: (+81) 3.3359.4309  
FAX: (+81) 3.3359.4307

M051-00K63-B124

05/05

Before using this product, it is essential to read this ENTIRE operation manual and ALL installation instructions.

This will help in setting up the equipment quickly and in instructing others on how to use it correctly and safely.

Avant toute utilisation de ce produit, il est indispensable de lire ce manuel d'utilisation dans son INTÉGRALITÉ, ainsi que TOUTES les instructions d'installations.

Ce manuel explique comment installer l'équipement et comment l'utiliser correctement et sans danger.

#### FCC Warning - Possible Radio / Television Interference

**NOTE:** This equipment has been tested and found to comply with the limits for a Class A digital device, pursuant to part 15 of the FCC rules. These limits are designed to provide reasonable protection against harmful interference when the equipment is operated in a commercial environment. This equipment generates, uses and can radiate radio frequency energy, and if not installed and used in accordance with the operation manual, may cause harmful interference to radio communications. Operation of this equipment in a residential area is likely to cause harmful interference in which case the user will be required to correct the interference at his own expense.

Class SA (Studio): Professional and / or commercial use.



**CAUTION: Any changes or modifications to this equipment could void the product warranty.**



**MISE EN GARDE: Tout changement et toute modification de ce matériel peut annuler la garantie du produit.**

Any service, other than cleaning or user maintenance, must be performed by an authorized service representative. There are no user-serviceable parts.

# TABLE OF CONTENTS

<b>Section</b>	<b>Description</b>	<b>Page</b>
1.	Getting Started	5
1.1	Important Safety Instructions	5
1.2	New Features	7
1.3	Setup	8
	Electrical Power Requirements // How to Position and Stabilize the Lifecycle® Upright Bike // How to Adjust the Seat // How to Adjust the Pedal Straps // Getting Started on the Bike Console // Fitness Networking // Cable TV Hook-up	
2.	The Display Console	12
2.1	The Display Console Overview	12
2.2	Display Console Descriptions	13
2.3	The Accessory Trays and Reading Rack	20
3.	Heart Rate Zone Training Exercise	21
3.1	Why Heart Rate Zone Training Exercise?	21
3.2	Heart Rate Monitoring	21
	The Lifepulse™ Digital Heart Rate Monitoring System // The Polar® Telemetry Heart Rate Monitoring Chest Strap	
4.	The Workouts	23
4.1	Workout Overviews	23
4.2	Using the Workouts	24
	Beginning a Workout // Selecting a Workout // Entering Workout Goals // Entering Workout Values // Selecting a Workout Mode // Changing/Ending Workouts	
4.3	Workout Descriptions	29
	Quick Start // Manual // Random // Fat Burn // Cardio // Hill // Around the World // Kilimanjaro // Interval // Cascades // Speed Training // Foothills // Heart Rate Hill™ // Heart Rate Interval™ // Extreme Heart Rate™ // Watts // METs // Aerobics Trainer // Life Fitness Fit Test // Air Force PRT	
5.	System Options Menu	41
5.1	Using the System Options Menu	41
5.2	Configuration Menu	42
	Manager's Configuration	
	Workout Duration Configuration // Language // User Language // Program Timeout // Units // System Beeps // Pause Time // Marathon Mode // Custom Message // Standby Configuration	
	TV / FM Radio	
	TV Setup // TV Channel Favorites // TV Channel Name/Sort // Secure Channel // Promo Channel Setup // FM Radio Setup	
	Custom Workouts	
	Export / Import Settings	
6.	Service and Technical Data	47
6.1	Preventive Maintenance Tips	47
6.2	Preventive Maintenance Schedule	48
6.3	Troubleshooting the Lifepulse™ System Sensors	48
6.4	Troubleshooting the Optional Polar Heart Rate Chest Strap	49
6.5	How to Obtain Product Service	50
7.	Specifications	51
7.1	Life Fitness 95Ce Lifecycle Upright Exercise Bike Specifications	51

This Operation Manual describes the functions of the  
Life Fitness Lifecycle® Upright Exercise Bike:

### 95Ce

See Section 7, titled *Specifications*, in this manual  
for product-specific features.

**Statement of Purpose:** The Life Fitness Lifecycle Upright Exercise Bike is a machine that simulates the movements of riding a bicycle at various speeds and levels of resistance.



Health-related injuries may result from incorrect or excessive use of exercise equipment. Life Fitness **STRONGLY** recommends seeing a physician for a complete medical exam before undertaking an exercise program, particularly if the user has a family history of high blood pressure or heart disease; or is over the age of 45; or smokes, has high cholesterol, is obese, or has not exercised regularly in the past year. Life Fitness also recommends consulting a fitness professional on the correct use of this product.

If, at any time while exercising, the user experiences faintness, dizziness, pain, or shortness of breath, he or she must stop immediately.



Des problèmes de santé peuvent être causés par une utilisation incorrecte ou excessive de l'équipement. Life Fitness conseille **VIVEMENT** de consulter un médecin pour subir un examen médical complet avant de commencer tout programme d'exercice, et tout particulièrement si l'utilisateur a des antécédents familiaux d'hypertension ou de troubles cardiaques, ou s'il a plus de 45 ans, s'il fume, s'il a du cholestérol, s'il est obèse ou n'a pas fait d'exercice régulièrement depuis un an. Life Fitness recommande également de consulter un professionnel du conditionnement physique pour savoir comment utiliser correctement ce produit.

Si, pendant l'utilisation de l'appareil, l'utilisateur ressent un malaise, des vertiges, des douleurs ou des difficultés à respirer, il doit s'arrêter immédiatement.

# 1 GETTING STARTED

## 1.1 IMPORTANT SAFETY INSTRUCTIONS

- **WARNING:** The safety of the product can be maintained only if it is examined regularly for damage and wear. See Preventive Maintenance section for details.
- **DANGER:** To reduce the risk of electrical shock, always unplug this Life Fitness product before cleaning or attempting any maintenance activity.
- **DANGER:** To reduce the risk of burns, fire, electric shock, or injury, it is imperative to connect each product to a properly grounded electrical outlet.
- Never operate a Life Fitness product if it has a damaged power cord or electrical plug, or if it has been dropped, damaged, or even partially immersed in water. Contact Life Fitness Customer Support Services for assistance.
- Keep the power cord away from heated surfaces. Do not pull the equipment by the power cord or use the cord as a handle. Do not run the power cord on the floor under or along the side of the bike.
- If the electrical supply cord is damaged, it must be replaced by the manufacturer, an authorized service agent, or a similarly qualified person to avoid a hazard.

### LOCATION

- Position this product so that the power cord plug is accessible to the user.
- Use the Life Fitness Lifecycle Upright Bike only as directed in this manual.
- Keep the area around the Lifecycle Upright Bike clear of any obstructions, including walls and furniture. Provide at least three feet of clearance behind the unit.
- Do not use the Lifecycle Upright Bike outdoors, near swimming pools, or in areas of high humidity.
- Do not allow other people to interfere in any way with the user or equipment during a workout.
- Supervise closely any children or disabled persons using the Lifecycle Upright Bike.

### OPERATION

- Always follow the console instructions for proper operation.
- Do not reach into, or underneath, the unit; and do not tip the unit on its side during operation.
- Never insert objects into any opening of the Lifecycle Upright Bike. If an object should drop inside, carefully retrieve it while the unit is not in use. If the object cannot be reached, contact Life Fitness Customer Support Services.
- Never place containers filled with liquids directly on the unit, except in the accessory tray water bottle holder. Containers should be covered with lids.
- Wear shoes with rubber or high-traction soles. Do not use shoes with heels, leather soles, cleats, or spikes. Make sure no stones are embedded in the soles.
- Do not use the Lifecycle Upright Bike with bare feet.
- Keep all loose clothing, shoelaces, and towels away from moving parts.
- Use caution when stepping on or off of the Lifecycle Upright Bike.
- Never face backward while using the Lifecycle Upright Bike.

**SAVE THESE INSTRUCTIONS FOR FUTURE REFERENCE.**

# 1 POINT DE DÉPART

## 1.1 CONSIGNES DE SÉCURITÉ IMPORTANTES

- **AVERTISSEMENT:** Ce produit ne peut demeurer sécuritaire que s'il est régulièrement examiné pour y déceler les dommages éventuels et l'usure. Voir la section sur l'entretien préventif pour avoir de plus amples renseignements.
- **DANGER:** Pour réduire les risques de décharge électrique, toujours débrancher cet appareil Life Fitness avant le nettoyage ou toute mesure d'entretien.
- **DANGER:** Pour réduire les risques de brûlures, d'incendie, de décharges électriques ou de blessures, chaque appareil doit absolument être branché sur une prise électrique correctement mise à la terre.
- Ne jamais faire fonctionner un produit Life Fitness dont la fiche ou le cordon d'alimentation est endommagé, ni aucun appareil qui serait tombé ou aurait été endommagé ou même partiellement plongé dans l'eau. Appeler le service à la clientèle de Life Fitness pour obtenir de l'aide.
- Tenir le cordon d'alimentation à l'écart de toute surface chauffée. Ne pas tirer l'appareil par le cordon d'alimentation; ne pas utiliser le cordon comme poignée. Ne pas faire passer le cordon sur le sol, sous l'appareil ni le long de l'appareil.
- Si le cordon d'alimentation électrique est endommagé, il doit être remplacé par le fabricant, par un réparateur agréé ou par un dossier individuel travailleur qualifié afin d'éviter tout danger.

### ENDROIT

- Placer ce produit de manière à ce que l'utilisateur puisse accéder à la fiche du cordon d'alimentation.
- Utiliser le vélo d'exercice allongé Lifecycle uniquement de la façon indiquée dans le présent manuel.
- Maintenir la zone autour de l'appareil libre de toute obstruction, y compris murs et meubles. Prévoir un dégagement d'au moins un mètre derrière l'appareil.
- Ne pas utiliser le vélo d'exercice Lifecycle à l'extérieur, près d'une piscine ou dans des endroits très humides.
- Ne laisser personne nuire à l'utilisateur ou entraver le fonctionnement de l'équipement pendant une séance d'exercices.
- Surveiller étroitement les enfants ou les personnes handicapées qui utilisent le vélo d'exercice.

### FONCTIONNEMENT

- Les instructions de la console doivent toujours être suivies pour obtenir un fonctionnement correct.
- Ne pas placer les mains dans l'appareil ou sous l'appareil, et ne pas le renverser sur le côté pendant le fonctionnement.
- Ne jamais insérer d'objets dans un orifice du vélo d'exercice Lifecycle. Si un objet tombe à l'intérieur de l'appareil, l'extraire soigneusement pendant que l'appareil n'est pas utilisé. S'il est impossible d'atteindre l'objet, communiquer avec le service à la clientèle de Life Fitness.
- Ne jamais placer de contenants remplis de liquide directement sur l'appareil, sauf dans le plateau pour accessoires ou un support prévu à cet effet. Il est recommandé d'utiliser des contenants munis d'un couvercle.
- Porter des chaussures avec des semelles en caoutchouc ou offrant une très bonne adhérence. Ne pas utiliser de chaussures à talons, à semelles en cuir ou munies de crampons. S'assurer qu'aucun caillou n'est incrusté dans les semelles.
- Ne pas utiliser le vélo d'exercice Lifecycle pieds nus.
- Éloigner les vêtements lâches, les lacets et les serviettes des pièces en mouvement.
- Être prudent pour monter sur le vélo d'exercice Lifecycle ou pour en descendre.
- Ne jamais faire face vers l'arrière pendant l'utilisation du vélo d'exercice Lifecycle.

**CONSERVER CES INSTRUCTIONS POUR TOUT USAGE ULTÉRIEUR.**

## 1.2 NEW FEATURES

The Integrated LCD Console on the Life Fitness Lifecycle Upright Bike brings together the best LCD technology and the best cardio equipment. It combines eye-catching entertainment with an interactive exercise experience.

### NEW FEATURES ON THE LIFECYCLE UPRIGHT BIKE INCLUDE:

- **New Touchscreen Display:** This integrated, intuitive touchscreen features built-in intelligence. This gives exercisers the freedom to watch their favorite TV program and monitor their entire workout progress at the same time, all on one screen.  
See Section 2.2 *Display Console Descriptions, Workout Progress*.
- **Ergonomic Viewing:** The ergonomically-positioned viewing angle provides optimal comfort and reduces glare. Plus the protective layer on the Touchscreen Display eliminates direct contact and preserves the life of the LCD screen.
- **Easy Start-up:** It's no longer necessary to pedal to get started. Instead, choose and set up a workout, and begin pedaling when the workout begins.  
See Section 4.2 *Using the Workouts*
- **Improved Interface:** The sharp screen image, and attractive graphics makes the screen easier to read and to use. There are no complicated steps to setting up a workout—simply choose a workout, enter values and get started.  
See Section 4.2 *Using the Workouts*
- **New Help Files:** Now, choosing a workout can be an informed decision. Simply select the question mark on the workout selection screen to access help files, which give explanations of each of the workouts.  
See Section 2.2 *Display Console Descriptions, Workout Selection, Help*
- **Workout Flexibility:** Choosing a different workout “on the fly” is as simple as selecting a button, and choosing a new workout. And now there are two ways to change a workout parameter mid-workout—either use the keys on the Control Panel, or use the buttons on the Touchscreen Display.  
See Section 4.2 *Using the Workouts, Changing/Ending Workouts, Switching Workouts “On-the-Fly”*
- **Better Monitoring:** The Touchscreen Display shows all relevant workout statistics at one glance.  
See Section 2.2 *Display Console Descriptions, Workout Progress*
- **New Time Views:** Allows the user to choose the most motivating time display for them. Time can be viewed as Elapsed Time, Remaining Time, or Hidden Time. Changing time views is as simple as touching a button.  
See Section 2.2 *Display Console Descriptions, Workout Progress, Elapsed Time*
- **More Options for Managers:** More ways for managers to monitor statistics, track usages, and record personalized messages. Channel setup for the TV and FM Radio allows managers to control which channels are accessible by users. User Language selection allows managers to make multiple languages available for user interaction.  
See Section 5 *System Options Menu*
- **New Zero (0) Resistance Level:** This new resistance level gives more people the opportunity to enjoy a quality workout, regardless of experience level or physical ability. It also gives the bike more flexibility for incorporation into injury rehabilitation.  
See Section 4.2 *Using the Workouts, Entering Workout Goals, Entering and Adjusting the Intensity Level*.



- **Secure Channel:** Lets the manager dedicate and secure a single TV channel. A password can be assigned for access to a secure channel.  
See Section 5.2 *Configuration Menu, Secure Channel*.
- **Promo Channel:** Lets the manager dedicate a single TV channel for promotional use.  
See Section 5.2 *Configuration Menu, Promo Video*.
- **FM Radio:** Managers now have the ability to enable FM radio. Channel setup for FM Radio allows managers to control which channels are available to a user.  
See Section 2.2 *Display Console Descriptions, Workout Progress, Elapsed Time*.
- **Marathon Mode:** The new Marathon Mode option, when enabled, allows users to workout indefinitely.  
See Section 4.2 *Using the Workouts, Using Marathon Mode*.
- **User Language Selection:** Managers can now configure the display to prompt a user for a choice of language by which to interact with a program. Choose any combination of available languages to create a customized user language selection list.  
See Section 5.2 *Configuration Menu, User Language*.

## 1.3 SETUP

Read the entire Operation Manual before setting up the Lifecycle Upright Bike.

### ELECTRICAL POWER REQUIREMENTS

The Lifecycle Upright Bike requires an AC power supply according to the electrical configurations listed in the chart below.

Supply Voltage (VAC)	Frequency (Hz)	Rated Current (Amps)
100	50 / 60	1.6
110	50 / 60	1.6
120	50 / 60	1.6
200	50 / 60	.8
220	50 / 60	.8
230	50 / 60	.8
240	50 / 60	.8

**NOTE:** Do not modify the plug provided with this product. If the plug does not fit into an available electrical outlet, have a proper outlet installed by a qualified electrician.

## HOW TO POSITION AND STABILIZE THE LIFECYCLE® UPRIGHT EXERCISE BIKE

Following all safety instructions in Section 1.1, move the bike to the location in which it will be used. See Section 7, titled *Specifications*, for the dimensions of the product footprint (assembled dimensions). Allow a distance of 8 to 12 inches, or 21 to 30 centimeters, between the bike and other objects or surfaces on either side. Allow a distance of 3 feet, or 1 meter, from the front or rear of the bike to any other object or surface.

After placing the bike in position, check the unit's stability by attempting to rock it from side to side. Any slight rocking indicates that the unit must be leveled. Determine which foot is not resting completely on the floor. Loosen the jam nut (A) with an open-end 9/16-inch wrench, and rotate the stabilizing foot (B) to lower it. Verify that the bike is stable, and repeat the adjustment as necessary until the unit no longer rocks. Lock the adjustment by tightening the jam nut against the stabilizer bar.

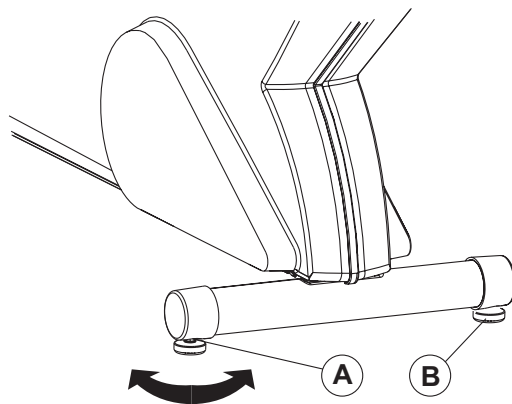

## HOW TO ADJUST THE SEAT

A properly adjusted seat is extremely important in any bike-oriented exercise activity and the Lifecycle Upright Bike is no exception. If the seat is too close, excessive strain will be placed on the knees and quadriceps muscles; if the seat is too far, the resulting reaching action will irritate the feet, ankles, hips and knees.

Sit on the seat and place the balls of the feet on the pedals. An optimum position will allow movement through the bottom of the stroke without locking the knees or shifting in the seat. The knees should have a slight bend at the point of fullest leg extension.

If the seat needs to be adjusted, lift the spring-loaded adjusting handle located on the right, front side of the seat. Slide the seat forward or backward as necessary to the proper position and release the pin to complete engagement. Gently slide the seat forward and backward a small distance to ensure it is locked into place. Check the seat distance again and re-adjust it if necessary.

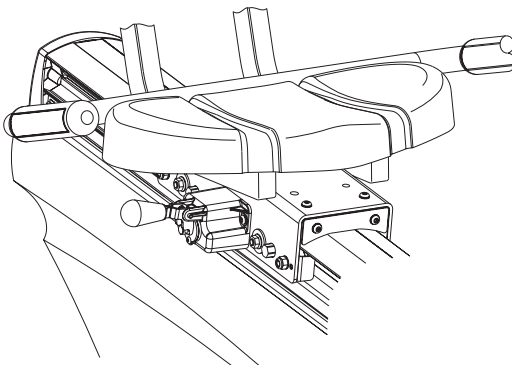

**CAUTION:** Do not attempt to adjust the seat while pedaling the bike. Doing so, or failing to insert the seat pin completely may result in an uncomfortable workout or cause injury.



**MISE EN GARDE :** Ne pas essayer d'ajuster la selle pendant le pédalage. Tout ajustage en cours de fonctionnement ou toute insertion incomplète de la goupille de la selle pourrait nuire à l'exercice ou entraîner des blessures.

## HOW TO ADJUST THE PEDAL STRAPS

The bike pedal straps keep the user's shoes on the pedals during a workout. The straps should fit comfortably, but they also should be tight enough to prevent shoes from slipping at any point in the pedaling rotation. Before working out, a user should test and adjust the tightness of the straps.

The safety straps on the foot pedals of the Lifecycle Upright Bike can be adjusted to fit a variety of shoe sizes. The straps are held in place by two knobs that extend from either side of each pedal. The "inner" knob extends sideways, that is, toward the bike. The "outer" knob extends downward. The ends of each strap are perforated with slots that fit tightly over the knobs. The "inner" end of each strap is perforated with two slots, and the "outer" segment of the strap is perforated with a row of slots.

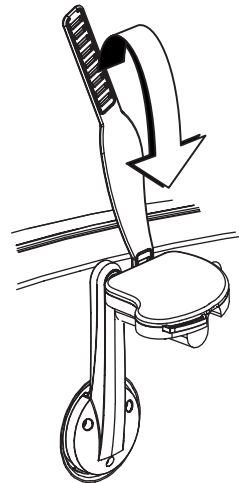

To tighten or loosen a strap, grasp the outer end, and pull it back, away from the knob, until the strap slides off. Pull the strap out through the outer loop on the pedal. Rest the foot on the pedal, and wrap the strap over the foot to determine the desired length. Thread the strap through the outer loop on the pedal, tuck it under the pedal, select the appropriate slot, and pull that slot down over the knob, until the top of the knob pops through the slot. A click indicates that the strap is locked into place.

## GETTING STARTED ON THE BIKE CONSOLE

Simply touch the Touchscreen Display to get started and access the Workout Selection screen. If the user simply starts pedaling and does not select a workout, the console automatically starts the Manual Program. But if the screen is touched, and there is no activity (either pedaling or selecting a workout) the console will return to the Welcome Screen. For information on setting up a workout, see Section 4.2, titled *Using the Workouts*.

## FITNESS NETWORKING

One type RJ45 networking port (A) allows the Lifecycle Upright Bike to be connected to a network, such as FitLinxx® interactive fitness network.

The network connection enables the console to upload user workout statistics to a fitness network database or to download remotely stored information, such as a pre-set workout program.

See Section 4.2, titled *Using the Workouts*, for information on logging onto a network.

This port is located on the back of the bike console and is enclosed by a removable cover. Any use of the port for other than its intended purpose could void the product warranty.



## CABLE TV HOOK-UP

### **Note to the CATV Installer:**

*This reminder is provided to call the CATV system installer's attention to Article 820-40 of the NEC that provides guidelines for proper grounding and, in particular, specifies that the cable ground shall be connected to the grounding system of the building as close to the point of cable entry as practical.*

### **Antenna Grounding According to the NEC**

Antenna Grounding According to the National Electrical Code, ANSI/NFPA 70.

1. Antenna lead in wire
2. Antenna discharge unit (nec section 810-20)
3. Grounding conductors (nec section 810-21)
4. Ground clamp
5. Power service grounding electrode system (nec article 250, part h)
6. Ground clamp
7. Electric service equipment

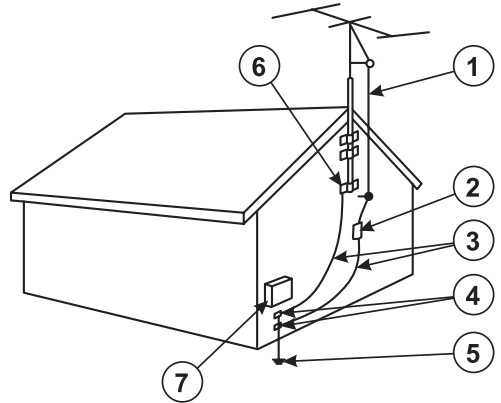

**NOTE:** The TV aspect of the LCD Console can only receive a analog signal. Digital cable must be externally converted to an analog signal. A 75-ohm external antenna terminal for VHF/UHF (>43dBuV (@75ohm) or > 65.8dBm) TV signal input must be present before TV setup can occur.

Life Fitness is not responsible for the installation of CATV service or components required for the delivery of CATV service.

# 2 THE DISPLAY CONSOLE

## 2.1 DISPLAY CONSOLE OVERVIEW

The computerized console on the Lifecycle Upright Bike allows the user to tailor a workout to personal fitness abilities and goals and to monitor progress. With this easy-to-use console, the user can track fitness improvement from one workout to the next.

The console consists of two parts:

**The Touchscreen Display:** The Touchscreen Display (the LCD screen) allows the user to easily choose a workout, set it up, and monitor it.

**The Control Panel:** The Control Panel consists of the keys on the bottom part of the console housing. These keys allow quick changes to workouts “on the fly,” provide easy access to TV controls, and allow for screen cleaning without activating the Touchscreen Display.



## 2.2 DISPLAY CONSOLE DESCRIPTIONS

This section lists and describes the functions for the buttons on the Touchscreen Display and the keys on the Control Panel on the Lifecycle Upright Bike. See Section 4, titled *The Workouts*, for detailed information on using the console to set up workouts.

### TOUCHSCREEN DISPLAY

The Touchscreen Display allows the user to move from screen to screen by simply selecting buttons to access other screens. The Touchscreen Display enables users to access:

- 1) **WORKOUT SELECTION** — choose a workout.
- 2) **WORKOUT SETUP** — enter workout values and goals.
- 3) **WORKOUT PROGRESS** — monitor progress, edit workout goals, and access TV viewing.

### 1) WORKOUT SELECTION

Touch the Welcome Screen anywhere to start and enter the Workout Selection screen. Use the Workout Selection screen to choose a workout, access QUICK START, or to access the Help Screens.

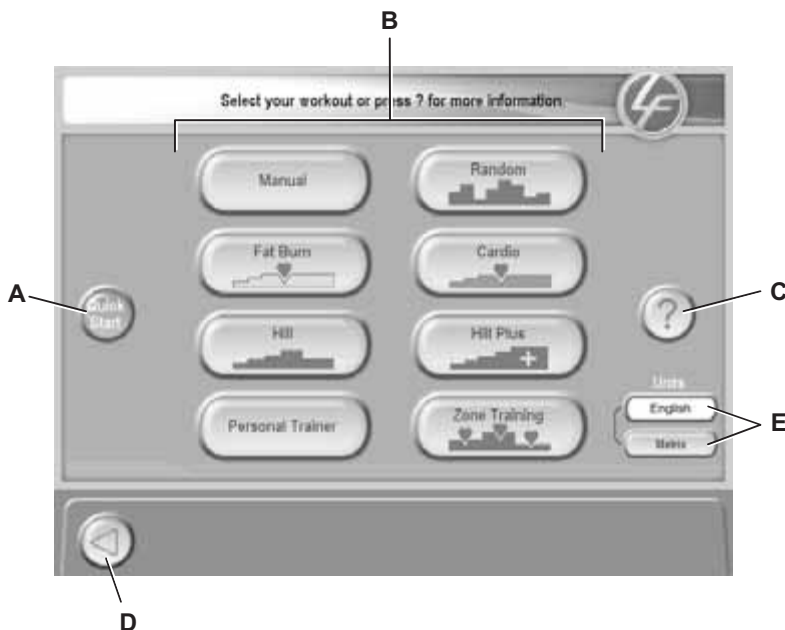

- A. QUICK START:** Select this button to enter directly into a workout, bypassing any setup or goal setting. Once started, the user can then make adjustments to the workout. Choose **LEVEL** to determine the level of intensity, **ENTER WEIGHT** to see METs, and **BIKE** and **CONSTANT CALS/HR** to determine how calories are computed. (See the end of this section for more information on **BIKE** and **CONSTANT CALS/HR. MODES**) Select the **COOLDOWN** button on the Control Panel to enter a Cooldown Phase.
- B. WORKOUT SELECTIONS:** Allows the user to choose from eight different programs. **MANUAL, RANDOM, FAT BURN, CARDIO, AND HILL** lead straight into workout setup screens. **HILL PLUS, ZONE TRAINING, AND PERSONAL TRAINER** give additional workout selections.

Choose **HILL PLUS** for **AROUND THE WORLD, KILAMANJARO, INTERVAL, CASCADES, SPEED TRAINING,** and **FOOTHILLS.**

Choose **ZONE TRAINING** for **HR Hill, HR INTERVAL,** and **EXTREME HR.**

Choose **PERSONAL TRAINER** for **WATTS, METs, AEROBICS TRAINER, LIFE FITNESS FIT TEST** and **AIR FORCE PRT.**

See Section 4.1 *Workout Overviews* for a description of each workout.

Buttons with a heart symbol access workouts that require heart rate monitoring. For more information, see *Workout Profile Window* under *Workout Progress.*

- C. **HELP (?)**: Select the HELP button to access help buttons for each of the workouts. Use these buttons to get a detailed explanation of each of the workouts.
- D. **BACK (<)**: Select BACK to move backward one screen.
- E. **UNITS**: (if enabled) Select the unit format for display. Choose from English or Metric.

## 2) WORKOUT SETUP

WORKOUT SETUP screens are accessed automatically upon selection of a workout program. They allow the user to enter values or to choose a goal for the workout selected. These depend on the workout, but might include goal type (time, distance or calories), level, age, weight, target heart rate\* (for heart rate programs), and for more advanced users, Watts and METs.

- F. **MESSAGE AREA**: Shows the user what workout is currently being set up. It also prompts the user for needed information or gives explanations.

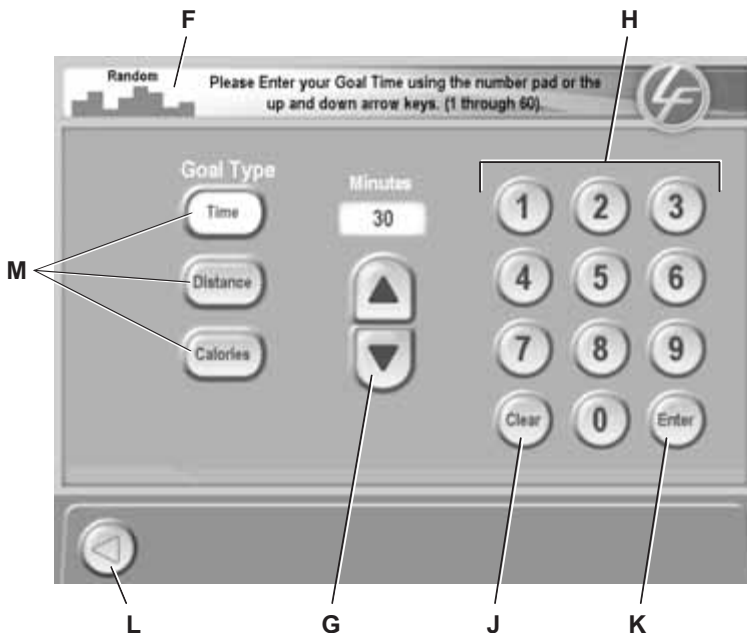

- G. **ARROW BUTTONS**: Use the UP and DOWN arrows to adjust workout values/goals such as length of workout, weight, age, target heart rate, and intensity level. Press ENTER to record the selection.
- H. **NUMERICAL KEYPAD**: Another way for the user to enter workout parameters. Key in the desired number on the keypad and press ENTER.

\* Target Heart Rate (THR) is a percentage of the theoretical maximum. For example, a 40-year-old user's THR for the **FAT BURN** workout is 117. This workout targets 65 percent of the maximum, so the equation would be  $(220-40) \cdot 65=117$

- J. CLEAR: Clears any entry and returns the default setting.
- K. ENTER: Press this button after entering a value to register the value and move to the next screen.
- L. BACK: Returns to the previous screen.

## TYPES OF WORKOUT SETUP SCREENS

### GOAL SETUP SCREENS

- **Goal Type:** The default setting of Goal Type is TIME (length of workout). Allows the user to choose a predetermined length of time for the workout.

Users may also choose a more advanced Goal Type such as DISTANCE, CALORIES, or TIME IN ZONE (only available for heart rate programs).

For Distance, Calories, and Time in Zone, the length of the workout depends on how long it takes to reach the goal. The workout continues until the goal is met. To exit early, either choose COOLDOWN from the Control Panel to go immediately into the Cooldown Phase, or choose CHANGE WORKOUT to access a different program. For more information, see Section 4.2 *Using the Workouts, Selecting a Goal Type*.

**NOTE:** Once a goal type is set, it cannot be changed during a workout, without using the RESET button, resetting the workout.

For information on how to set, and get maximum benefit from, these type of workout goals consult a Personal Trainer. For further information on Zone Training see section 3.1 of *Heart Rate Zone Training* titled *Why Heart Rate Zone Training Exercise?*

- **Level:** Choose the programmed intensity level of the workout. Levels range from 0 to 25.
- **Target Heart Rate:** (heart rate workouts only) Gives a recommended heart rate\* according to age. For **Fat Burn**, the target heart rate is computed at 65% of the theoretical maximum<sup>†</sup> heart rate. For **Cardio**, the target heart rate is computed at 80%. For more information on Target Heart Rate, see Section 3, *Heart Rate Zone Training Exercise*.
- **Watts:** The Watt is a unit of power output or the expression of the mechanical rate of work. For the Watts program, the user sets a goal time, and then the program provides the level of exertion needed to keep the Watts equal to the goal during the duration of the workout.
- **METs:** The MET is an expression of the rate of work for the human body at rest, or a metabolic equivalent; one MET is approximately equal to the metabolism of a person at rest. For the METs program, the user sets a goal time, and then the program provides the level of resistance needed to bring METs expended equal to the goal during the duration of the workout.

### VALUE SETUP SCREENS

- **Weight:** Enter an accurate weight so that METs can be calculated. (If weight is entered METs will toggle with WATTS on the Workout Progress Screen.)
- **Age:** Allows heart programs to accurately determine target heart rate.
- **Gender:** For accurate Fitness Testing.

<sup>†</sup> Defined by the American College of Sports Medicine's "Guidelines for Exercise Testing and Prescription" as equal to 220 minus an individual's age.

\* Target Heart Rate (THR) is a percentage of the theoretical maximum. For example, a 40-year-old user's THR for the **FAT BURN** workout is 117. This workout targets 65 percent of the maximum, so the equation would be  $(220-40) \cdot 65 = 117$



### 3) WORKOUT PROGRESS

The Workout Progress screen opens automatically upon completion of the setup, signaling the user to start the workout. The Workout Progress screen allows the user to monitor the progress of the workout. It provides a visual representation of the workout as it proceeds and monitors Distance, Calories, Watts, METs, Time, Level and RPM (depending on which workout is selected). From here TIME, LEVEL, TARGET HEART RATE\*, and MODE (Bike or Constant Cals/Hr.) can be changed at any point during a workout. This screen also allows access to TV viewing.

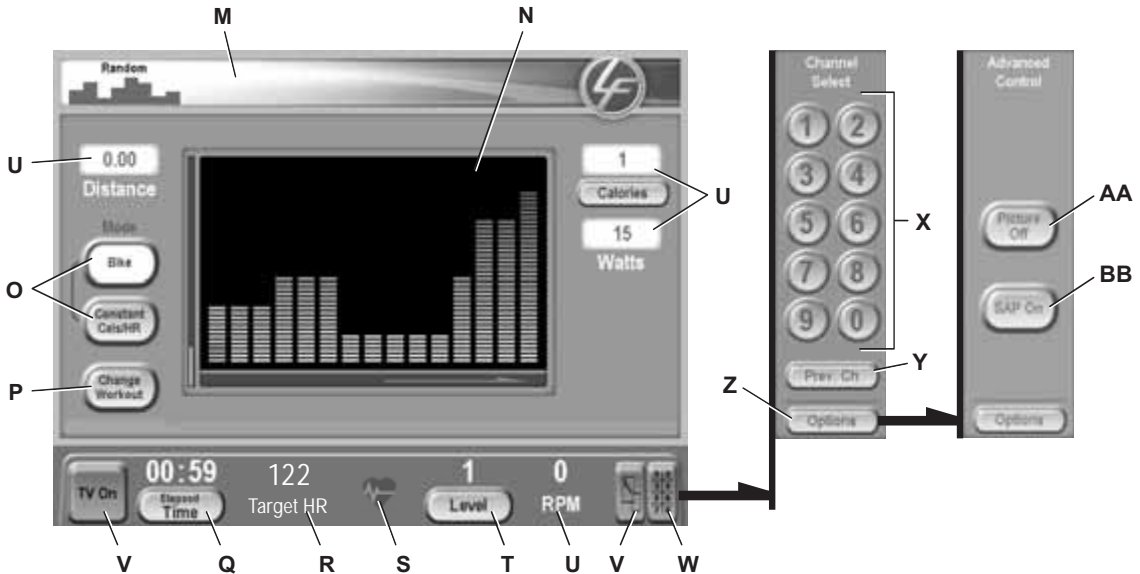

**M. MESSAGE AREA:** Shows the user the workout type, prompts the user for needed information, and explains concepts.

**N. WORKOUT PROFILE WINDOW:** This window displays the levels of intensity in a workout-in-progress as proportional columns. The height of the column furthest to the left is proportional to the current level of intensity. (When the TV is on it covers this window.)

\*During a **FAT BURN, CARDIO, HEART RATE HILL, HEART RATE INTERVAL, or EXTREME HEART RATE** workout, which requires the use of a Polar heart rate chest strap or the Lifepulse™ system sensors, the **WORKOUT PROFILE** window displays a flashing heart shape to request the user's heart rate signal. If the console does not detect a signal, the **MESSAGE AREA** displays the prompt, "NEED HEART RATE- PLACE HANDS ON LIFEPUULSE SENSORS OR USE TELEMETRY STRAP" and beeps three times. If the console does not receive the signal within three minutes, the workout automatically is converted to a **MANUAL** program.

**O. MODE:** Use Mode to choose Bike Mode or Constant Cals/HR. The default setting is Constant Cals/Hr.

- **Bike Mode:** Select this button to activate the Bike Workout Mode in which the rate of calories burned and the total distance travelled increase automatically as the user increases the pedaling speed. (Bike Mode is not available for heart rate workouts.)
- **Constant Cals/HR:** Press this key to maintain a constant rate of calories burned per hour. For more information about Bike Mode and Constant Calories Per Hour Mode, see the topic *Selecting a Workout Mode* in Section 4.2, titled, the *Using the Workouts*.

\* Target Heart Rate (THR) is a percentage of the theoretical maximum. For example, a 40-year-old user's THR for the **FAT BURN** workout is 117. This workout targets 65 percent of the maximum, so the equation would be  $(220-40) \cdot 65 = 117$

- P. CHANGE WORKOUT:** Choose this button to go back to the workout selection screen and choose a new workout, or to change a goal type of value, while retaining workout progress. To change workouts, choose the new program, enter any remaining values, and press ENTER. To return to the current workout without making any changes, choose BACK. Select RESET on the workout selection screen to clear all the stored information about the current workout, before changing to a new program.

To adjust a goal type (Calories, Distance, or if in a heart rate program, Time in Zone) or choose a different goal while retaining workout progress, select Change Workout, and then ADJUST GOAL, which accesses the goal type screen defaulted to the current goal type and value. To change the goal value, use the arrow buttons or the numerical keypad, change the value, and then select ENTER. To change the goal type,

- Q. ELAPSED TIME:** Use this button to change the length of the workout, or to choose a different view for time. ELAPSED TIME is the default view, but time can also be viewed by REMAINING TIME, or HIDDEN TIME. To change the time view select ELAPSED TIME, choose a different time view and press ENTER.

To change the length of a workout midstream, press the ELAPSED TIME button which also accesses Goal Time. Then use the arrow buttons or the numerical keypad, make the adjustment and select ENTER. (Use the arrow keys on the Control Panel directly underneath ELAPSED TIME to change length of workout time without leaving the Workout Progress Screen.)

**NOTE:** Changing the length of a workout by using the TIME ELAPSED button has no effect on the time elapsed, which is an ongoing measurement of the time already spent in a workout.

- R. TARGET HEART RATE:** (for heart rate workouts only) Displays the target heart rate\* the user has specified in the workout setup screens. Can be changed anytime during a workout, by using the arrow keys directly below it, or by touching the TARGET HEART RATE button on the Touchscreen and accessing the Target Heart Rate Workout Setup Screen.
- S. ACTUAL HEART RATE:** Displays the heart rate if the user grasps the Lifepulse sensors or wears a Polar-compatible heart rate chest strap. **NOTE:** Heart rate can be checked on any of the screens, whether before a workout begins, or during a workout.
- T. LEVEL:** Displays the programmed intensity level. Select LEVEL and then use the arrow buttons or the numerical pad to make a new selection. Press ENTER. (Use the arrow keys on the Control Panel directly underneath Level to change the level of exertion without leaving the Workout Progress Screen.)
- U. WORKOUT STATISTICS:** Continually updates the workout progress by showing Distance, Calories Burned (switches between calories burned and calories per hour), Watts, Heart Rate (on any workout if the user is grasping the Lifepulse sensors or wearing a telemetry strap), Target Heart Rate (switches between target heart rate and actual heart rate) and RPM.
- Cal/Hr and METs/Watts have buttons beneath the displays which give added functionality. These buttons can be used to lock the display or to force the display to toggle. To lock the display, (for instance, turn off the toggle so only calories burned is displayed) simple press the button once while the desired setting is displayed. To toggle (for instance, if METs is displayed to change the display immediately to Watts) press the button twice in succession
- V. TV SELECTION:** TV ON/OFF accesses the TV, and enables the Channel and Volume keys on the Surrounding Console. TV ZOOM (far bottom right) toggles between large and small screen TV viewing.

\* Target Heart Rate (THR) is a percentage of the theoretical maximum. For example, a 40-year-old user's THR for the **FAT BURN** workout is 117. This workout targets 65 percent of the maximum, so the equation would be  $(220-40) \cdot 65 = 117$

- W. CHANNEL CONTROLS:** Accesses the Channel Select keypad on the touchscreen.
- X. NUMERICAL KEYPAD:** Use to enter a new channel selection.
- Y. PREVIOUS CHANNEL:** Select this button to change the channel to the immediately previous channel viewed.
- Z. OPTIONS:** Use to access channel interface menu options. Advanced Control is accessible by default. If enabled, Favorites and Channel List channel selection menus are also accessible.  
**ADVANCED CONTROL:** Use to access advanced picture/audio control menu. See Section 5.1 System Options Menu, TV / FM Radio Settings for more information.
- AA. PICTURE OFF:** Use to disable TV video. Allows only the TV audio to be heard. Reset TV video using the picture on button in the upper right of the display. Picture on is not available for channels pre-configured for audio only.
- BB. SAP OFF:** Use to enable Second Audio Program. SAP is used to receive audio in another language or to receive Descriptive Video Service broadcast on multi-channel stereo television sets.

### OPTIONAL CHANNEL SELECTION MENUS

If Favorites and/or Channel List options are enabled, an Options menu will be enabled for selecting a desired channel selection interface.

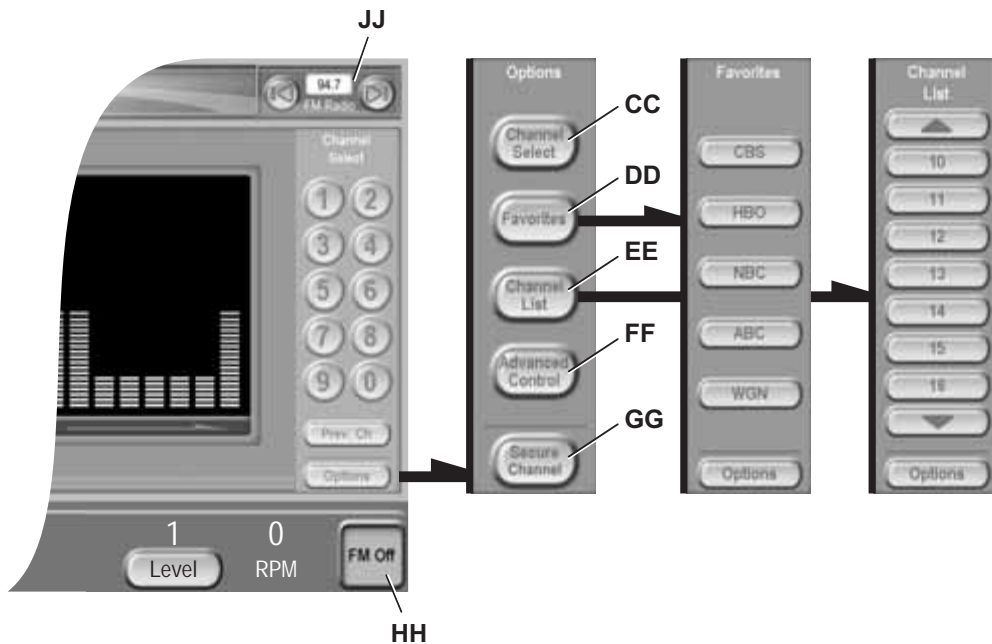

- CC. CHANNEL SELECT:** Accesses the Channel Select keypad.
- DD. FAVORITE:** If enabled, use to toggle to Favorite Channel selection. See Section 5.1 System Options Menu, TV / FM Radio Settings for more information.
- EE. CHANNELS LIST:** If enabled, use to toggle to Channel List selection. See Section 5.1 System Options Menu, TV / FM Radio Settings for more information.
- FF. ADVANCED CONTROL:** Use to access advanced picture/audio control menu. See Section 5.1 System Options Menu, TV / FM Radio Settings for more information.

- GG. SECURE CHANNEL:** If enabled, use to access a dedicated channel for non-broadcast usage. This channel may require a password for viewing. See Section 5.1 System Options Menu, TV / FM Radio Settings for more information.
- HH. FM SELECTION: FM On/OFF:** If enabled, use to access FM Radio. See Section 5.1 System Options Menu, TV / FM Radio Settings for more information.
- JJ. FM CONTROLS:** If enabled, use to access available FM Radio stations. Use the seek forward and back buttons to select the next available station. See Section 5.1 System Options Menu, TV / FM Radio Settings for more information.

Additional buttons appearing in the Workout Progress Screen for different workouts:

**TIME IN ZONE:** Displays the accumulated time that the heart rate stays within the selected target zone for a Heart Rate Zone Training workout. See section 3, titled *Heart Rate Zone Training Exercise*, for more information.

#### 4) CONTROL PANEL

The Control Panel allows the user to control workout and TV parameters without leaving the Workout Progress screen. It also provides a quick and easy way for maintenance staff to clean the Touchscreen Display without activating the screen.

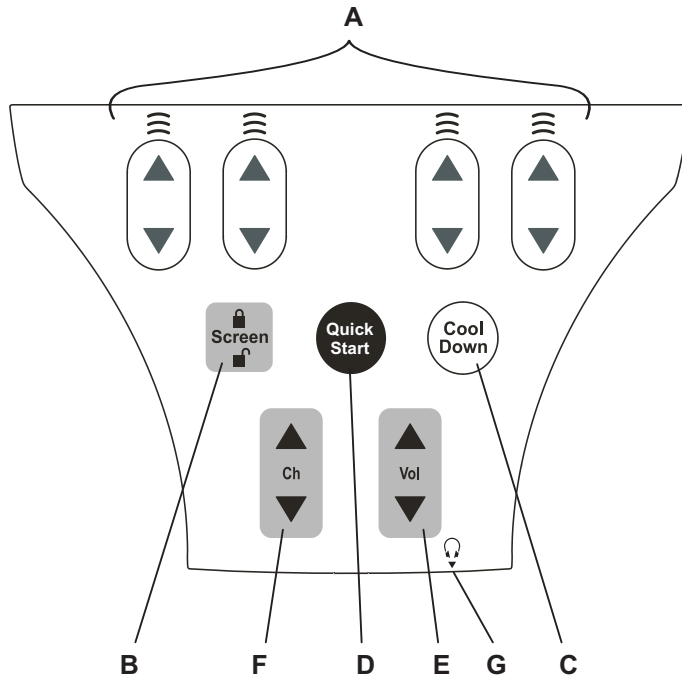

- A. ARROW KEYS:** When in the workout phase, the UP and DOWN arrow keys are used in combination with the Touchscreen Display. These keys allow the user to make changes to a workout goal during the workout. Each set of arrow keys controls the goal located directly above it on the Touchscreen Display.

Changeable information (i.e. a workout goal) either appears as a button (Time, Level, or Target Heart Rate\*) or is accessible through CHANGE WORKOUT, ADJUST GOAL (Calories, Distance, and for heart rate programs, Time in Zone). Workout statistics are not changeable.

\* Target Heart Rate (THR) is a percentage of the theoretical maximum. For example, a 40-year-old user's THR for the **FAT BURN** workout is 117. This workout targets 65 percent of the maximum, so the equation would be  $(220-40) \cdot 0.65 = 117$

For example, use the arrow keys under ELAPSED TIME to change the goal time for the session. Workout statistics, such as RPM (revolutions per minute), cannot be changed. As described above, workout goals may also be changed by touching the corresponding button on the Touchscreen Display and accessing the corresponding Workout Setup screens.

- B. SCREEN LOCK/UNLOCK:** (Cannot be used during a workout.) Freezes the screen for the purpose of routine maintenance/ screen cleaning. The screen automatically unlocks after ten seconds. Pressing SCREEN LOCK a second time will unlock it as well.
- C. COOLDOWN:** Workout programs end automatically in a Cooldown phase, which lowers the intensity level. In this phase of a workout the body begins to remove lactic acid and other accumulated by-products of exercise, which build up in muscles during a workout and contribute to muscle soreness.

Press the COOLDOWN key to enter the Cooldown stage at any point during the workout. Each workout's Cooldown level is automatically adjusted according to the individual user's performance. (Cooldown times are preset in proportion to the duration of a workout.) The Cooldown time can be changed by using the corresponding arrow keys on the Control Panel. At the end of Cooldown, a workout summary box appears.

- D. QUICK START:** Choose this to enter directly into a workout, bypassing setup screens
- E. VOL:** Volume control for the TV.
- F. CH:** Channel control for the TV.
- G.  :** Headphone jack for sound playback.

**NOTE:** Headphones are necessary to access the sound for the TV. The jack is located on the Control Panel on the lower right. The jack is a user-replaceable feature. Contact Life Fitness Customer Support Services for more information. (See Section 6.7 "How to Obtain Product Service" for contact information.)

## 2.3 THE ACCESSORY TRAYS AND READING RACK

The accessory tray (A), which is mounted on the right handlebar the Lifecycle Upright Bike, provides storage space for items such as water bottles, personal stereos, and cell phones.

The ledge (B) on the Touchscreen Display can also be used as a reading rack for books or magazines. Use care when placing reading materials on the rack, and when turning pages, to ensure that buttons aren't accidentally toggled.

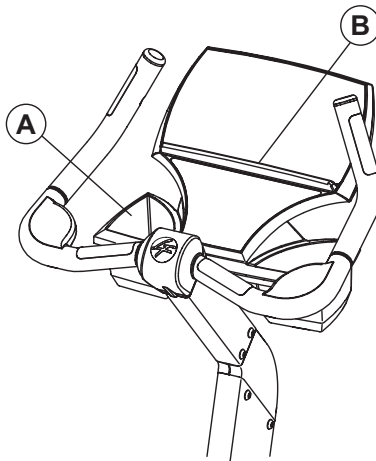

# 3 HEART RATE ZONE TRAINING EXERCISE

## 3.1 WHY HEART RATE ZONE TRAINING EXERCISE?

Research shows that maintaining a specific heart rate while exercising is the optimal way to monitor the intensity of a workout and to achieve maximum results. That is the idea behind the Life Fitness heart rate zone training approach to exercise.

Zone training identifies an exerciser's ideal heart rate range, or zone, for burning fat or increasing cardiovascular fitness. The values within the zone depend on the workout.

**NOTE:** Consulting a fitness trainer is recommended for defining specific fitness goals and designing a workout program.

The Lifecycle Upright Bike features five exclusive workouts designed to take full advantage of the benefits of heart rate zone training exercise: **FAT BURN**, **CARDIO**, **HEART RATE HILL**, **HEART RATE INTERVAL**, and **EXTREME HEART RATE**. The Time in Zone Goal option, another feature of heart rate zone training, enhances these workouts by setting a certain duration within the target zone as a workout goal. For detailed information about the workouts, as well as the Time In Zone Goal option, see Section 4, titled *The Workouts*.

During one of these workouts, grasp the Lifepulse system sensors, or wear the Polar heart rate chest strap to enable the bike's on-board computer to monitor the heart rate. The computer automatically adjusts the resistance level to maintain the target heart rate\* based on the actual heart rate.

To change the target heart rate\* during a workout, use the arrow keys on the Control Panel, or touch the TARGET HR button on the Touchscreen Display, and then enter the new heart rate using the keypad or the arrow keys, and select ENTER.

ZONE TRAINING		
FAT BURN = LOW INTENSITY		
CARDIO = HIGH INTENSITY		
AGE	65%	80%
10	136	168
20	130	160
30	123	152
40	117	144
50	110	136
60	104	128
70	97	120
80	91	112
90	84	104
100	78	96

SUGGESTED TARGET HEART RATE AS % OF MAX ACSM HEART RATE RANGE:  
55% - 90%

\* Target Heart Rate (THR) is a percentage of the theoretical maximum. For example, a 40-year-old user's THR for the **CARDIO** workout is 144. This workout targets 80 percent of the maximum, so the equation would be  $(220-40) \cdot 80 = 144$ .

## 3.2 HEART RATE MONITORING

### THE LIFEPUULSE™ DIGITAL HEART RATE MONITORING SYSTEM

The patented Lifepulse system sensors are the built-in heart rate monitoring system on the Life Fitness Lifecycle Upright Bike. During a workout, grasp the sensors (A) that are set into the handlebars. For an accurate reading, use a comfortable grip. The console displays the heart rate after 10 to 40 seconds.

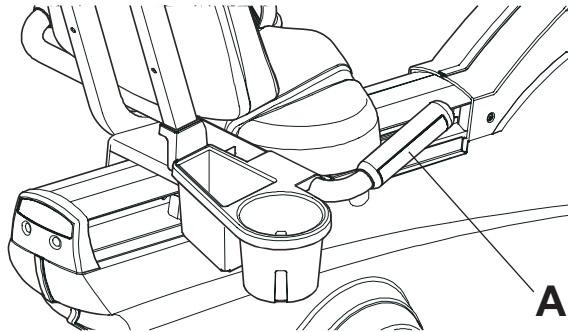

### THE POLAR® TELEMETRY HEART RATE MONITORING CHEST STRAP

The Lifecycle Upright Bike is equipped with Polar telemetry, a heart rate monitoring system in which electrodes, pressed against the skin, transfer heart rate signals to the bike console. These electrodes are attached to a chest strap that the user wears during the workout. The chest strap is optional. To order it, call Life Fitness Customer Support Services. See Section 6.5, titled *How to Obtain Product Service*.

See the diagram below for correct positioning of the strap. The electrodes (A), which are the two grooved surfaces on the underside of the strap, must remain wet to transmit accurately the electrical impulses of the heart back to the receiver. Moisten the electrodes. Then, secure the strap as high under the chest muscles as possible. The strap should be snug, but comfortable enough to allow for normal breathing.

The transmitter strap delivers an optimal heart rate reading when the electrodes are in direct contact with skin. However, it also functions properly through a thin layer of wet clothing.

If it becomes necessary to re-moisten the chest strap electrodes, grasp the center of the strap, pull it away from the chest to expose the two electrodes, and moisten them.

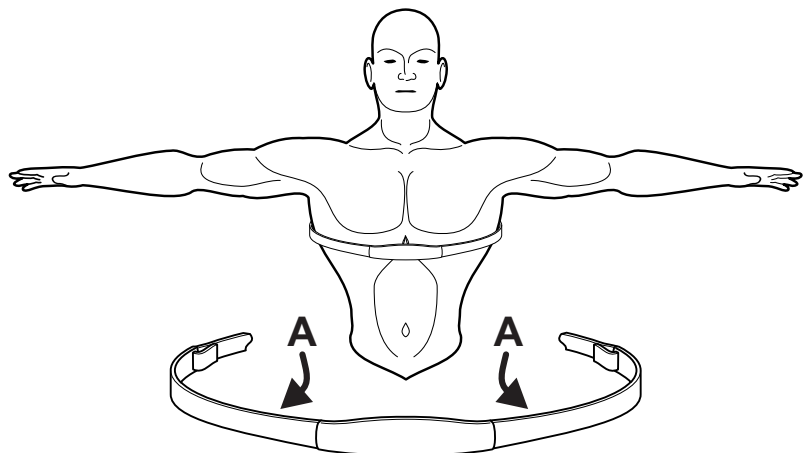

# 4 THE WORKOUTS

## 4.1 WORKOUT OVERVIEWS

This section lists the Lifecycle Upright Bike's pre-programmed workouts. For more detailed information, see Section 4.2, titled *Using the Workouts*.

**QUICK START** is the fastest way to begin exercising, and it bypasses the steps involved in selecting a specific workout program. After the QUICK START key is pressed, a constant-level workout begins. The intensity level does not change automatically.

**MANUAL** is a workout in which the intensity level does not change automatically.

**FAT BURN** is a low-intensity workout for burning the body's fat reserves. The user must wear a Polar heart rate chest strap, or grasp the Lifepulse system sensors continuously. The workout program automatically adjusts the intensity level, based on the actual heart rate, to maintain the rate at 65 percent of the theoretical maximum<sup>†</sup>.

**HILL** is an interval-training workout combining "hills" and "valleys" of different intensity levels, which is proven to provide effective, time-efficient cardiovascular results.

**RANDOM** is an interval training workout of constantly changing intensity levels that occur in no regular pattern or progression.

**CARDIO** is a higher intensity workout for more fit users, emphasizing cardiovascular benefits and maximum fat burning. The user must wear a Polar heart rate chest strap, or grasp the Lifepulse system sensors continuously. The workout program automatically adjusts the intensity level, based on the actual heart rate, to maintain the rate at 80 percent of the theoretical maximum<sup>†</sup>.

**ZONE TRAINING** are workouts that target specific ranges, or zones, for maintaining a heart rate to achieve maximum exercise results. Zone Training workouts include:

**HEART RATE HILL** takes the user through three different hills based on the target heart rate\*. The user must grasp the Lifepulse system sensors continuously or wear a Polar heart rate chest strap.

**HEART RATE INTERVAL** alternates between a hill and a valley based on the target heart rate\*. The user must grasp the Lifepulse system sensors continuously or wear a Polar heart rate chest strap.

**EXTREME HEART RATE** is an intense workout for more experienced users. It is designed to get the heart rate up and down as quickly as possible. The user must grasp the Lifepulse system sensors continuously or wear a Polar heart rate chest strap.

**HILL PLUS** are workouts in which intensity levels increase and decrease in set patterns. The following workouts may be accessed with this button:

**AROUND THE WORLD** is an interval-training workout in which the hills resemble scenes of various geographical areas.

**FOOTHILLS** is a rolling hill workout with low intensity levels.

**KILIMANJARO** is a Hill workout in which the intensity levels gradually incline toward one ultimate peak and then gradually decline.

<sup>†</sup> Defined by the American College of Sports Medicine's "Guidelines for Exercise Testing and Prescription" as equal to 220 minus an individual's age.

\* Target Heart Rate (THR) is a percentage of the theoretical maximum. For example, a 40-year-old user's THR for the **HEART RATE HILL** workout is 144. This workout targets 80 percent of the maximum, so the equation would be  $(220-40) \cdot 80 = 144$ .



**INTERVAL** is a Hill workout in which intensity levels rise and fall. The higher levels gradually incline toward a peak and then gradually decline.

**CASCADES** is a two-peak workout in which intensity levels gradually increase and decrease.

**SPEED TRAINING** is a Hill workout in which the intensity level alternates between high and low levels very quickly to simulate a typical speed-training workout.

**PERSONAL TRAINER** workouts are customized workouts designed either for the advanced user or to be used in connection with a personal trainer. These workouts include:

**WATTS** targets a rate of effort equal to a certain number of Watts.

**METs** targets a rate of effort equal to a certain number of METs.

**AEROBICS TRAINER** is a workout that prompts the user to switch continuously between a high and low pedaling speeds. The speed intervals alternate in a pattern that promotes a build-up in the intensity of the workout, followed by a build-down in intensity.

**LIFE FITNESS FIT TEST** measures cardiovascular fitness compared to other people of the same age and gender.

**AIR FORCE PRT** is similar to the Fit Test workout, except that this program is based upon a specific predefined protocol. The available test is: **AIR FORCE PHYSICAL READINESS TEST (PRT) - (U.S. MILITARY)**

## 4.2 USING THE WORKOUTS

Different bike workouts require different setup steps. This section provides details on the steps themselves. (See the chart, titled *Lifecycle Upright Bike Workout Setup Steps* at the end of this section for a quick glance at the steps for setting up any workout program.)

### 1) BEGINNING A WORKOUT

**Without networking**, touch the screen to START. The Message Area displays the prompt: "Select your workout or press ? for more information." Choose a workout program to begin.

**If equipped with optional networking**, touch the screen to START. The Message area displays the prompt: "SELECT YOUR WORKOUT, ENTER YOUR NETWORK ID, OR PRESS ? FOR MORE INFORMATION" and an "NETWORK ID" button will appear on the Workout Selection Screen. Select a workout, or log on to the networked exercise database and download the preset workout.

To log onto the network, press NETWORK ID and key in the user ID number with the NUMERIC KEYPAD. Press ENTER.

### SELECTING AND USING QUICK START

**QUICK START** is the fastest way to begin exercising, and it bypasses the steps of selecting a specific workout program. On the start screen press the QUICK START button. The workout begins at an intensity level that remains the same unless manually changed. In order for METs to be displayed on the Workout Progress Screen choose ENTER WEIGHT.

## 2) SELECTING A WORKOUT

When prompted to select a workout, select the desired workout button. The touchscreen will then bring up the corresponding Workout Setup Screens which include level, age, weight, target heart rate\*, Watts and METs. Press ENTER after each selection to record it. After values are set, the workout progress screen appears and the workout begins.

For **MANUAL, FAT BURN, HILL, RANDOM,** and **CARDIO** choose the corresponding button to enter directly into the workout setup screens.

For **HEART RATE HILL, HEART RATE INTERVAL,** and **EXTREME HEART RATE** choose **ZONE TRAINING** and then make a selection.

For **WATTS, METS, AEROBICS TRAINER, LIFE FITNESS FIT TEST** and **AIR FORCE PRT** choose **PERSONAL TRAINER** and then make a selection.

For **AROUND THE WORLD, KILIMANJARO, INTERVAL, CASCADES, SPEED TRAINING,** and **FOOTHILLS** select **HILL PLUS** and then make a selection.

## 3) ENTERING WORKOUT GOALS

### SELECTING A GOAL TYPE

Goal Type defaults to TIME (length of workout). When prompted to enter a Goal Time, use the ARROW KEYS to increase or decrease the displayed time to the desired value, or key in the desired value with the NUMERIC KEYPAD, and press ENTER.

Workouts can be programmed to target certain types of goals other than the default time goal:

- Distance
- Calories
- Time in zone (for heart rate workouts only)

The **Distance Goal** feature is designed to build endurance. The user sets a distance goal during the workout setup. Once the goal is met, the workout automatically goes into a Cooldown Phase and ends afterward. To use this feature:

1. Select a workout (the distance goal is available for any of the workouts.)
2. In the Goal Type setup screen, choose DISTANCE, enter the desired distance goal, and select ENTER.
3. Finish the setup steps for the selected workout.
4. Begin the workout.

The **Calories Goal** feature is designed to promote weight loss and weight control. The user sets a calorie goal during the workout setup. Once the goal is met, the workout automatically goes into a Cooldown Phase and ends afterward. To use this feature:

1. Select a workout (the calorie goal is available for any of the workouts.)
2. In the Goal Time setup screen, choose CALORIES, enter the desired calorie goal, and select ENTER.
3. Finish the setup steps for the selected workout.
4. Begin the workout.

The **Time in Zone** goal enhances a heart rate workout by setting a certain duration within the target heart rate\* as a workout goal. The program automatically alters the resistance to maintain a pace that will meet that objective within that duration. Once the objective is met, the workout automatically goes into a Cooldown Phase. To use the Time In Zone Goal feature:

1. Select either **FAT BURN, CARDIO**, or any of the **Zone Training** workouts including **HEART RATE HILL, HEART RATE INTERVAL**, or **EXTREME HEART RATE**.
2. In the Goal Time setup screen, choose TIME IN ZONE, enter the desired amount of time, and select ENTER.
3. Finish the setup steps for the selected workout.
4. Begin the workout.

**NOTE:** Time in Zone is directly correlated to fitness level. Since the program will continue to increase resistance until the goal is met, it may be wise to start low and work towards a higher goal. Choose COOLDOWN at any time, to exit the workout and immediately enter a Cooldown Phase.

For help setting Time in Zone goals, consult a personal trainer. For more information on Heart Rate Zone Training, see Section 3.1 *Why Heart Rate Zone Training?*

### **SELECTING AND ADJUSTING THE INTENSITY LEVEL**

When prompted, use the ARROW keys to increase or decrease the displayed intensity level or target heart rate\* to the desired value, or choose the desired value with the NUMERIC KEYPAD, and press ENTER. Adjust the level as needed or desired during the workout.

- Intensity level: The Lifecycle Exercise Bike provides a selection of 26 intensity levels (0 to 25). The Workout Profile Window displays the levels of intensity in a workout-in-progress as proportional columns. The height of the column furthest to the left is proportional to the current level of intensity. Selecting a low intensity level at first is recommended. As physical conditioning improves, the levels can increase.
- Target heart rate: Programs that calculate a target heart rate\* base this number on the age of the user and the type of workout. The user accepts or adjusts the rate when setting up the workout. During the workout itself, the program reads the heart rate, which is transmitted via the Polar heart rate chest strap or the Lifepulse system sensors; and it uses this data to adjust the resistance. Manually raising the rate increases the intensity of the cardiovascular exercise.

## **4) ENTERING WORKOUT VALUES**

**AGE:** When prompted to enter Age, use the ARROW KEYS to increase or decrease the displayed age to the correct value, or key in the correct value with the NUMERIC KEYPAD, and press ENTER.

Lifecycle Upright Bike workout programs that set a target heart rate\* zone first calculate the user's theoretical maximum heart rate<sup>†</sup> by subtracting the user's age from the number 220. The programs then calculate the target zone as a percentage of the theoretical maximum.

**WEIGHT:** Select weight and press enter. Entering an accurate weight allows the program to display METs. (If weight has been entered, METs toggle with WATTS on the Workout Progress Screen.)

**GENDER:** Select gender and press enter. (Only used for the Fitness Testing workouts)

\* Target Heart Rate (THR) is a percentage of the theoretical maximum. For example, a 40-year-old user's THR for the **FAT BURN** workout is 117. This workout targets 65 percent of the maximum, so the equation would be  $(220-40) \times .65 = 117$ .

## 5) SELECTING A WORKOUT MODE

All workouts on the Lifecycle Upright Bike default to a Constant-Calories-Per-Hour Mode. The Bike Mode provides another option for varying workouts. The Bike Mode is accessed on the Workout Progress Screen under Mode. **NOTE:** Bike Mode is not available on any of the heart workouts.

- **Bike Mode:** This workout mode simulates the experience of riding a real bicycle. The rate of calories burned and total distance travelled increase automatically as the user increases the pedaling speed. To select Bike mode, press BIKE MODE button.
- **Constant-Calories-Per-Hour Mode:** This workout mode enables a user to maintain a consistent rate of calories burned per hour. As the pedaling speed increases, the resistance level automatically decreases. As the pedaling speed decreases, the resistance level automatically increases. This mode can be used with all workouts.

To change modes during a workout:

1. Select any program that does NOT require a heart rate measurement.
2. Set up the program through the setup screens.
3. Begin the workout.
4. On the workout progress screen, beneath Mode, choose BIKE MODE. The message area displays the message, "Bike Mode — Resistance is independent of RPM."
5. Continue the workout.
6. To change back to Constant Calories per hour, choose the Constant Cals/HR button at any point. The message area displays the message, "Constant Cals/Hr — Resistance will vary with RPM."

## 6) CHANGING/ENDING WORKOUTS

### SWITCHING WORKOUTS "ON-THE-FLY"

It is possible during a workout, to switch to another workout program. After a switch, the console retains all the progress information about the workout since its beginning. To change workouts "on the fly," simply press CHANGE WORKOUT and then choose a new workout. To switch to a new workout, and restart the progress information, choose CHANGE WORKOUT and then RESET. **NOTE:** All workouts can be switched "on-the-fly" (retaining progress information) except for Hill Plus workouts. To change from a Hill Plus workout to another workout, the user must select CHANGE WORKOUT and RESET (losing workout progress).

### CHANGING WORKOUT GOALS DURING A WORKOUT

During a workout, it is possible to change a workout goal type (Time, Distance, Calories, and Time in Zone for heart rate programs). To adjust a goal type or choose a different goal, select CHANGE WORKOUT, and then ADJUST GOAL, which accesses the goal type screen defaulted to the current goal type and value. To change the goal value, use the arrow buttons or the numerical keypad, change the value, and then select ENTER. To change the goal type, choose a different goal, enter a value, and select ENTER. After the switch, the console retains all the progress information about the workout since its beginning.

## **PAUSING WORKOUTS**

To pause a workout, simply stop pedaling. An EXIT WORKOUT button appears. Selecting EXIT WORKOUT takes the user out of the workout, back to the Welcome Screen. To continue the workout, resume pedaling. The pause duration defaults to 1 minute (configurable by the manager), after which, the console returns to the Welcome Screen.

## **ENDING WORKOUTS EARLY**

To end a workout early, press COOLDOWN on the Control Panel to go directly into the Cooldown Phase. The program will designate a Cooldown time period in proportion to the amount of time spent in the workout. Upon completion of Cooldown, a workout summary will appear, which includes the distance travelled, the total calories burned, and other statistics. To exit the program without a Cooldown, choose CHANGE WORKOUT, and then RESET.

## **7) USING MARATHON MODE**

If Marathon Mode is enabled, a Marathon Mode button will appear in the time entry screen when configuring a workout. Selecting Marathon Mode sets the workout to an unlimited time workout. The workout can then be ended only by the user.

Within a workout, Marathon Mode can be changed by pressing the Time Key. Pressing the Time Key makes it possible to set a time goal as long as it's not less than the time already spent in the workout. A new time goal must be set and entered to override Marathon Mode.

## 4.3 WORKOUT DESCRIPTIONS

### LIFECYCLE UPRIGHT EXERCISE BIKE WORKOUT SETUP STEPS

**NOTE:** AFTER ENTERING A VALUE (AGE, WEIGHT, HEIGHT, GENDER) OR A GOAL (TIME, LEVEL, THR), PRESS ENTER TO REGISTER THE SELECTION.

SELF-CONTAINED WORKOUTS	PERSONAL TRAINER WORKOUTS	HILL PLUS WORKOUTS	ZONE TRAINING WORKOUTS
<p><b>QUICK START</b>            Select QUICK START            Begin workout            Modify level            Enter weight if desired</p> <p><b>RANDOM</b>            Select RANDOM            Enter goal type and value            Select level            Begin workout</p> <p><b>MANUAL</b>            Select MANUAL            Enter goal type and value            Select level            Begin workout</p> <p><b>FAT BURN*</b>            Select FAT BURN            Enter goal type and value            Enter age            Accept THR**            Begin workout</p> <p><b>HILL</b>            Select HILL            Enter goal type and value            Select level            Begin workout</p> <p><b>CARDIO*</b>            Select CARDIO            Enter goal type and value            Enter age            Accept THR**            Begin workout</p>	<p><b>CHOOSE PERSONAL TRAINER TO ACCESS ANY OF THE FOLLOWING:</b></p> <p><b>WATTS</b>            Select WATTS            Enter goal type and value            Enter Watts goal value            Begin workout</p> <p><b>METS</b>            Select METs            Enter goal type and value            Enter METs goal value            Begin workout</p> <p><b>AEROBICS TRAINER</b>            Select AEROBICS TRAINER            Enter goal type and value            Select level            Begin workout</p> <p><b>LIFE FITNESS FIT TEST**</b>            Select FIT TEST            Enter weight            Enter age            Enter gender            Enter level            Begin workout</p> <p><b>AIR FORCE PRT</b>            Select AIR FORCE PRT            Enter weight            Enter height            Enter age            Enter gender            Answer prompt            Begin workout</p> <p><b>CUSTOM WORKOUTS</b>            Select CUSTOM WORK-OUTS            Choose workout            (If custom workout type is Level)            Begin Workout            (If custom workout type is Target Heart Rate)            Enter Age.            Begin Workout</p>	<p><b>CHOOSE HILL PLUS TO ACCESS ANY OF THE FOLLOWING:</b></p> <p><b>AROUND THE WORLD</b>            Select AROUND THE WORLD            Enter goal type and value            Select level            Begin workout</p> <p><b>KILAMANJARO</b>            Select KILIMANJARO            Enter goal type and value            Select level            Begin workout</p> <p><b>INTERVAL</b>            Select INTERVAL            Enter goal type and value            Select level            Begin workout</p> <p><b>CASCADES</b>            Select CASCADES            Enter goal type and value            Select level            Begin workout</p> <p><b>SPEED TRAINING</b>            Select SPEED TRAINING            Enter goal type and value            Select level            Begin workout</p> <p><b>FOOTHILLS</b>            Press FOOTHILLS            Enter goal type and value            Select level            Begin workout</p>	<p><b>CHOOSE ZONE TRAINING TO ACCESS ANY OF THE FOLLOWING:</b></p> <p><b>HEART RATE HILL*</b>            Select HEART RATE HILL            Enter time            Enter age            Accept THR**            Begin workout</p> <p><b>HEART RATE INTERVAL*</b>            Select HEART RATE INTERVAL            Enter time            Enter age            Accept THR**            Begin workout</p> <p><b>EXTREME HEART RATE*</b>            Select EXTREME HEART RATE            Enter time            Enter age            Accept THR**            Begin workout</p>

\* This workout requires the user to wear the polar heart rate chest strap or the grip the Life pulse sensors.

\*\* Target Heart Rate (THR) is a percentage of the theoretical maximum. A 40-year-old user's THR for the **FAT BURN** workout is 117. This workout targets 65 percent of the maximum, so the equation would be  $(220-40) \cdot .65=117$ .

# WORKOUT DESCRIPTIONS (CON'T)

## QUICK START

**QUICK START** is the fastest way to begin exercising, and it bypasses the steps of selecting a specific workout program. The intensity level for the workout is set automatically and remains the same unless manually changed. To change the level and stay in the Workout Progress screen, press the UP or DOWN ARROW KEYS on the Control Panel, corresponding to the LEVEL button. Level can also be changed by touching the LEVEL button on the Touchscreen Display, and then changing the level using the arrow buttons or the numeric keypad and pressing ENTER.

For METs to be displayed during a workout, select the ENTER WEIGHT button which is required to calculate this value. (If weight is entered METs will toggle with WATTS on the display.) Using the ARROW KEYS, increase or decrease the displayed weight to the correct value, or enter weight using the NUMERIC keypad, and press ENTER to register.

## MANUAL

The **MANUAL** program sets an intensity level that does not change automatically. While the workout is in progress, increase or lower the intensity level as desired, using the arrow keys.

## RANDOM

The **RANDOM** program creates a terrain of hills and valleys that varies with each workout. More than one million different patterns are possible.

## FAT BURN

The **FAT BURN** workout is designed to maintain a user's heart rate at 65 percent of the theoretical maximum<sup>†</sup> for optimal results. Throughout the workout, the user wears a Polar heart rate chest strap or grips the Lifepulse system sensors. If the user is not wearing a chest strap or grasping the sensors, the WORKOUT PROFILE window displays a heart shape, and the display prompts the user to grip the sensors. The console continuously monitors and displays the heart rate, adjusting the intensity level of the Lifecycle Upright Bike to reach and maintain the target\*. This system eliminates over- and under-training, and it maximizes the aerobic benefits of exercise by using the body's fat stores for fuel.

## CARDIO

The **CARDIO** workout is virtually identical to **FAT BURN**; however the target heart rate\*\* is calculated at 80 percent of the theoretical maximum. The user wears a chest strap or grips the Lifepulse system sensors. The higher target promotes cardiovascular improvement by placing a heavier workload on the heart muscle.

<sup>†</sup> Defined by the American College of Sports Medicine's "Guidelines for Exercise Testing and Prescription" as equal to 220 minus an individual's age.

\* Target Heart Rate (THR) is a percentage of the theoretical maximum (HRmax). A 40-year-old user's recommended THR for the FAT BURN workout is 117, or 65 percent of the maximum, so the equation would be  $(220-40) \cdot 65 = 117$ .

\*\* Target Heart Rate (THR) is a percentage of the theoretical maximum (HRmax). A 40-year-old user's recommended THR for the CARDIO workout is 144, or 80 percent of the maximum; so the equation would be  $(220-40) \cdot 80 = 144$ .

# HILL

The Life Fitness-patented **HILL** workout offers a variety of configurations for interval training. Intervals are periods of intense aerobic exercise separated by regular periods of lower-intensity exercise. The **WORKOUT PROFILE** window represents these high and low intervals as columns of light, which together have the appearance of hills and valleys. The computerized interval training workout has been scientifically demonstrated to promote greater cardio-respiratory improvement than steady-pace training.

Each **HILL** workout goes through four phases, each marked by different intensity levels. The **WORKOUT PROFILE** window displays the progress of these phases, as seen in the chart following these descriptions below. As noted in the descriptions, the heart rate should be measured at two stages in the workout to gauge its effectiveness. To do so, wear the Polar heart rate chest strap or continuously grip the Lifepulse system sensors. Note that the **WORKOUT PROFILE** window does not display a request for a heart rate measurement during a **HILL** workout.

- 1 **Warm-up** is a phase of low, gradually rising resistance, which brings the heart rate into the lower end of the target zone and increases respiration and blood flow to working muscles.
- 2 **Plateau** increases the intensity slightly, and keeps it steady, to bring the heart rate to the low end of the target zone. Check the heart rate at the end of this phase.
- 3 **Interval Training** is a series of increasingly steeper hills, alternating with valleys, or stints of recovery. The heart rate should rise to the high end of the target\* zone. Check the heart rate at the end of this phase.
- 4 **Cooldown** is a low-intensity phase that allows the body to begin removing lactic acid, and other exercise by-products, which build up in muscles and contribute to soreness.

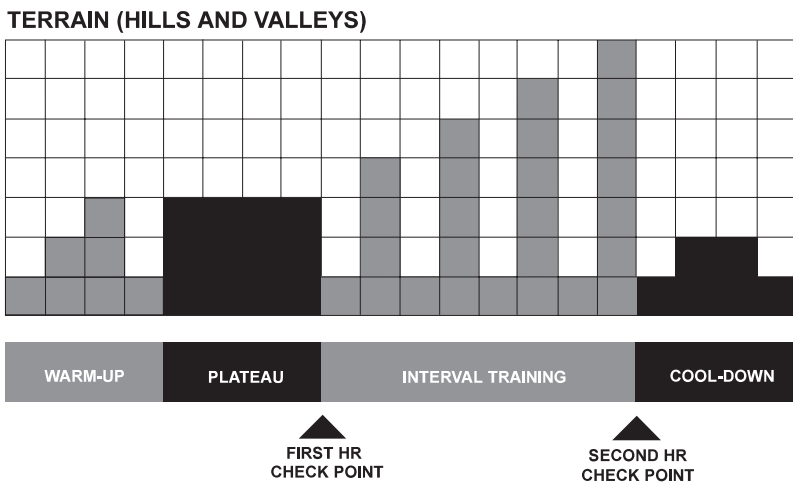

Each column, as seen in the **WORKOUT PROFILE** window and the chart above, represents one interval. The overall duration of the workout determines the length of each interval. Each workout is made up of 20 intervals, so the duration of each interval is equal to the duration of the entire workout divided by 20.



**1 to 9 minutes:** A workout with a duration of less than 10 minutes is insufficient for the Hill program to complete all four phases adequately. The program, therefore, condenses a workout of this duration at various stages.

**10 to 19 minutes:** The interval durations initially are set at 30 seconds for a 10-minute workout. For every minute added by the user “on the fly,” each interval increases by three seconds. A 15-minute workout consists of 20 intervals at 45 seconds each.

**20 to 99 minutes:** All intervals last 60 seconds. If the user adds minutes to the pre-set duration while the workout is in progress, the program adds hills and valleys that are identical to the first eight intervals of the Interval Training phase. This pattern repeats until the workout is completed.

## **HILL PLUS**

The Life Fitness patented **HILL PLUS** workouts give even more ways to vary interval training. Based on the same principles as the HILL workout, Hill Plus workouts are customized to resemble different locations/training scenarios to add variety and challenge to Hill workouts.

### **1) AROUND THE WORLD**

An interval-training workout in which the hills resemble scenes of various geographical areas.

### **2) CASCADES**

A two-peak workout in which intensity levels gradually increase and decrease.

### **3) FOOTHILLS**

A rolling hill workout with low intensity levels.

### **4) INTERVAL**

A Hill workout in which intensity levels rise and fall. The higher levels gradually incline toward a peak and then gradually decline.

### **5) KILIMANJARO**

A Hill workout in which the intensity levels gradually incline toward one ultimate peak and then gradually decline.

### **6) SPEED TRAINING**

A Hill workout in which the intensity level alternates between high and low levels very quickly to simulate a typical speed-training workout.

## ZONE TRAINING

**Zone Training** workouts target specific ranges, or zones, for maintaining a heart rate to achieve maximum exercise results.

### 1) HEART RATE HILL™

This program combines the standard **HILL** workout profile with the concept of Heart Rate Zone Training. The default target heart rate\* is calculated as 80 percent of the theoretical maximum† (HRmax), but the user can adjust the target rate during the workout setup. All hills and valleys are percentages of HRmax. The workout consists of three hills that target three heart rate goals: The first hill brings the heart rate to 70 percent of HRmax. The second hill increases the rate to 75 percent of HRmax. The third hill matches the Target Heart Rate bringing the heart rate to 80 percent of HRmax. The valley always is defined as 65 percent of HRmax.

After a standard three-minute warm-up, the workout progresses toward the first hill and heart rate goal. Once the user reaches 70 percent of HRmax, the hill continues for one minute. When the minute expires, the level decreases into a valley. Once the user's heart rate falls to 65 percent of HRmax, the valley continues for one minute. Then, the next hill begins with its corresponding heart rate goal. After the user completes the third hill/valley pair, the program returns to the first hill and repeats the cycle as long as the duration allows. At the end of the duration, the workout goes into a Cooldown Phase. If the heart rate goes above the theoretical maximum for more than 45 seconds, the exercise bike automatically goes into pause mode. The program does not proceed to a new heart rate goal until the user reaches the current goal.

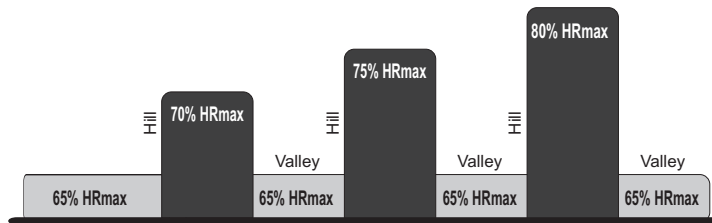

HEART RATE HILL Workout Profile

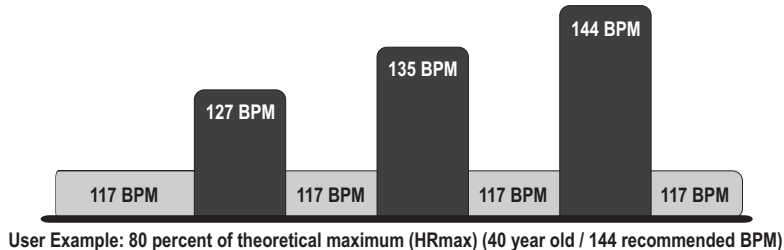

† Defined by the American College of Sports Medicine's "Guidelines for Exercise Testing and Prescription" as equal to 220 minus an individual's age.

\* Target Heart Rate (THR) is a percentage of the theoretical maximum (HRmax). A 40-year-old user's recommended THR for the HEART RATE HILL workout is 144 or 80 percent of the maximum; so the equation would be  $(220-40) \cdot 80 = 144$ .

## 2) HEART RATE INTERVAL™

This program also combines the standard **HILL** workout profile with the concept of Heart Rate Zone Training. The default target heart rate\* is calculated as 80 percent of the theoretical maximum† (HRmax), but the user can adjust the target rate during the workout setup. The workout alternates between a hill, which brings the heart rate up to the target rate of 80 percent of HRmax, and a valley, which brings the heart rate down to 65 percent of HRmax. After a standard three-minute warm-up, the workout progresses toward the first hill and heart rate goal. Once the goal is reached, the hill continues for three minutes. Then, the level decreases into a valley. Once the 65 percent of HRmax goal is reached, the valley continues for three minutes, after which the next hill begins. The user's fitness level determines the number of hills and valleys encountered within the duration. At the end of the duration, the workout goes into a Cooldown Phase. If the heart rate goes above the theoretical maximum† for more than 45 seconds, the exercise bike automatically goes into pause mode. The program does not proceed to a new heart rate goal until the user reaches the current goal.

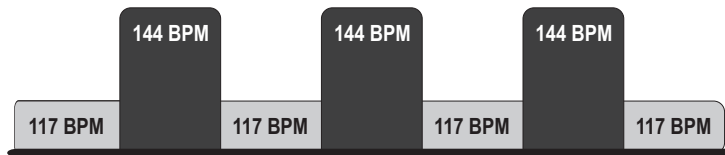
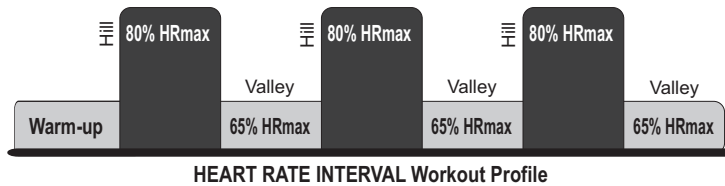

† Defined by the American College of Sports Medicine's "Guidelines for Exercise Testing and Prescription" as equal to 220 minus an individual's age.

\* Target Heart Rate (THR) is a percentage of the theoretical maximum (HRmax). A 40-year-old user's recommended THR for the HEART RATE INTERVAL workout is 144 or 80 percent of the maximum; so the equation would be  $(220-40) \cdot 80 = 144$ .

### 3) EXTREME HEART RATE™

This intense, varied workout is designed to help more experienced users to break through fitness improvement plateaus. The workout alternates between two target heart rates\* as quickly as possible. The effect is similar to that of running sprints. The user must wear a chest strap or grip the Lifepulse™ sensors throughout the workout.

When setting up the workout, the user enters a target heart rate. After a standard three-minute warm-up, the intensity increases, until the user reaches the target heart rate goal of 85 percent of the theoretical maximum† (HRmax). That target rate is maintained for a stabilizing period. Then, the intensity decreases. When the heart rate falls to the 65 percent of HRmax goal, it is maintained there for a stabilizing period. The program repeats the alternating of intensity levels, continuing this pattern throughout the duration. The program does not proceed to a new heart rate goal until the user reaches the current goal.

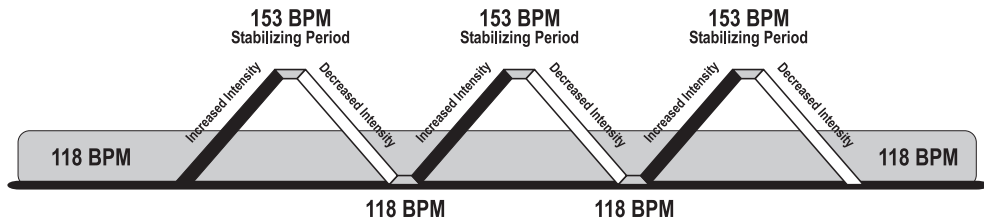
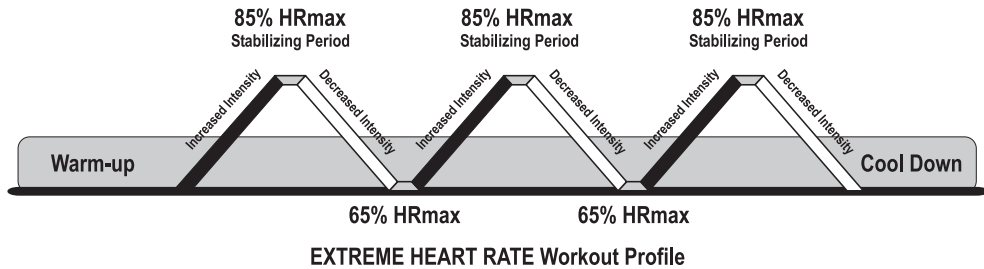

User Example 85 percent of theoretical maximum (HRmax) (40 year old / 153 recommended BPM)

† Defined by the American College of Sports Medicine's "Guidelines for Exercise Testing and Prescription" as equal to 220 minus an individual's age.

\* Target Heart Rate (THR) is a percentage of the theoretical maximum (HRmax). For example, a 40-year-old user's recommended THR for the EXTREME HEART RATE™ WORKOUT is 153. The workout program targets a standard 85 percent of the maximum, so the equation would be  $(220-40) \cdot 0.85 = 153$ .

## 4) PERSONAL TRAINER

Personal Trainer workouts are customized workouts designed either for the advanced user or to be used in connection with a personal trainer.

### 1) WATTS

This workout targets a rate of effort equal to a certain number of Watts. A Watt is a unit of power that measures the amount of mechanical work required to operate a device, such as a Lifecycle Upright Bike. It is roughly equal to .25 calories per hour. The workout program automatically alters the intensity level to maintain the appropriate rate of effort.

### 2) METs

This workout targets a rate of effort equal to a certain number of METs. A MET is a unit of measurement used to express the metabolic rate of work (oxygen consumption per unit of body weight) required to perform a task. One MET is approximately equal to a person's metabolism when seated and relaxed.

### 3) AEROBICS TRAINER

In this workout, the user is prompted to switch between a high pedaling speed and a low pedaling speed. These speed intervals alternate in a pattern that promotes a “build-up” in the intensity of the workout, followed by a “build-down” in intensity.

The workout consists of 32 intervals, which are divided into groups of four. In the first group, the user encounters one fast interval followed by three slow intervals. The second group features two fast intervals followed by two slow intervals. The third group features three fast intervals followed by one slow interval. The fourth group, which is the most intense point of the workout, features four fast intervals. Afterward, the workout decreases in intensity, concluding with a group of four, consecutive, slow intervals. See the chart below:

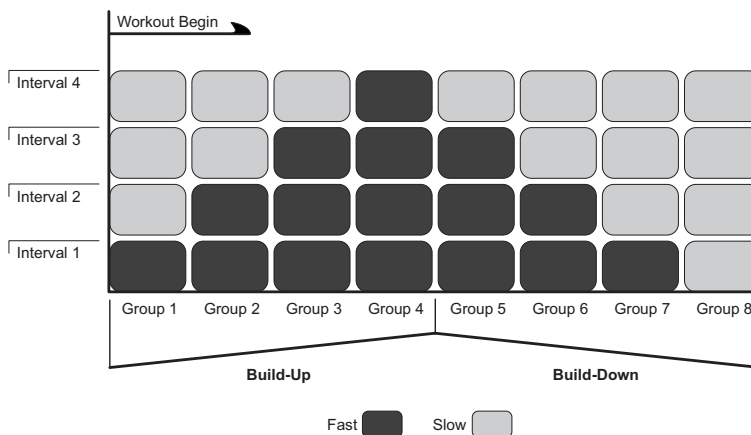

The length of the intervals depends on the workout duration selected by the user.

#### 4) LIFE FITNESS FIT TEST

The Lifecycle Upright Bike Fit Test program is another exclusive feature of this versatile exercise bike. The Life Fitness Fit Test measures cardiovascular fitness and can be used to monitor improvements in endurance every four to six weeks. The user must grasp the hand sensors when prompted or wear a heart rate chest strap, as the test score calculation is based on a heart rate reading. The workout duration will be five minutes at the chosen resistance level. Immediately afterward, the console will take the user's heart rate reading, calculate a fitness score, and display the score in a results window.

The Fit Test is considered to be a submax VO<sub>2</sub> (volume of oxygen) test. It gauges how well the heart supplies oxygenated blood to the exercising muscles, and how efficiently those muscles receive oxygen from the blood. Physicians and exercise physiologists generally regard this test as a good measure of aerobic capacity. Please note that the estimated VO<sub>2</sub> max scores achieved will be 10 percent to 15 percent lower on stationary exercise bikes than those achieved on other Life Fitness cardiovascular equipment. Stationary cycling has a higher rate of isolated muscle fatigue of the quadriceps when compared to walking/running on a treadmill, climbing on a stairclimber, or utilizing a cross-trainer. This higher rate of fatigue corresponds to lower levels of estimated VO<sub>2</sub> max scores.

To set up the Fit Test:

- Choose PERSONAL TRAINER, then LIFE FITNESS FIT TEST.
- Go through the setup screens for the Fit Test, including WEIGHT, AGE, AND GENDER. Press Enter after each selection to record the entry.
- Choose a workout level (ENTER LEVEL). Consult the following recommended fit test level chart for an appropriate effort level based on your age, gender and activity level. Use the NUMERIC BUTTONS or UP/DOWN ARROW BUTTONS to enter the corresponding level.

After the five-minute FIT TEST is completed, a FIT TEST score will be displayed.

#### FIT TEST PROGRAM SUGGESTED EXERTION LEVELS

	Inactive	Active	Very Active
Bike Fit Test Level	L4-6 men	L5-10 men	L8-14 men
	L2-4 women	L3-7 women	L6-10 women

Suggested exertion levels should be used as a guideline for setting up the Fit Test program. The goal is to elevate the user's heart rate to a level that is between 60%-85% of their theoretical maximum heart rate (220-age).

Within each suggested range, these additional guidelines can be used:

Lower Half of Range	Upper Half of Range
higher age	lower age
lower weight	higher weight*
shorter	taller

\* In cases of excessive weight, use lower half of range.

The computer will not accept:

- heart rates less than 52 or greater than 200 beats per minute
- body weights less than 75 pounds (34 kg) or greater than 400 pounds (182 kg)
- ages below 10 or over 99 years
- data input that exceeds human potential

If an error is made when entering any Fit Test data, correct it by pressing CLEAR, inputting the correct information, and pressing ENTER.

It is important to take the Fit Test under similar circumstances each time. Heart rate is dependent on many factors, including:

- amount of sleep the previous night (at least seven hours is recommended)
- time of day
- time of last meal (two to four hours after the last meal is recommended)
- time of last beverage containing caffeine or alcohol, or of a cigarette (at least four hours is recommended)
- time since last exercise (at least six hours is recommended)

For the most accurate Fit Test results, perform the Fit Test on three consecutive days and average the three scores.

**NOTE:** To receive a proper Fit Test score, the work done must be within a training heart rate zone that is 60 percent to 85 percent of the theoretical maximum heart rate. This rate is defined by the American College of Sports Medicine's "Guidelines for Exercise Testing and Prescription" as equal to 220 minus an individual's age.

The tables below list fit test results.

### RELATIVE FITNESS CLASSIFICATION FOR MEN

Men	Estimated VO2 Max (ml/kg/min) Per Age Category				
Rating	20-29	30-39	40-49	50-59	60+
Elite	52+	51+	48+	45+	42+
Excellent	50-51	48-50	46-47	42-44	39-41
Very Good	47-49	45-47	43-45	40-41	36-38
Above Average	44-46	42-44	40-42	37-39	33-35
Average	41-43	39-41	37-39	34-36	30-32
Below Average	38-40	36-38	34-36	31-33	27-29
Low	35-37	33-35	31-33	28-30	24-26
Very Low	<35	<33	<31	<28	<24

### RELATIVE FITNESS CLASSIFICATION FOR WOMEN

Women	Estimated VO2 Max (ml/kg/min) Per Age Category				
Rating	20-29	30-39	40-49	50-59	60+
Elite	44+	42+	39+	35+	34+
Excellent	42-43	40-41	37-38	33-34	32-33
Very Good	39-41	37-39	35-36	31-32	30-31
Above Average	37-38	35-36	32-34	29-30	28-29
Average	34-36	32-34	30-31	27-28	25-27
Below Average	31-33	29-31	27-29	25-26	23-24
Low	28-30	27-28	25-26	22-24	20-22
Very Low	<28	<27	<25	<22	<20

Life Fitness developed this rating scale based on VO2 max percentile distributions referenced in *American College of Sports Medicine's "Guidelines for Exercise Testing and Prescription"* (6th Ed. 2000). It is designed to provide a qualitative description of a user's VO2 max estimation, and a means of assessing initial fitness level and tracking improvement.



## **5) MILITARY FITNESS TEST**

### **AIR FORCE PRT**

The 95Ce exercise bike features an Air Force Physical Readiness Test (PRT). This test is similar to the fit test workout, except that it does not have a preset time goal. The Air Force PRT is located in the Personal Trainer Workouts.

To begin an Air Force PRT:

- Choose PERSONAL TRAINER, AIR FORCE PRT.
- Go through the setup screens for the Fit Test, including WEIGHT, AGE, AND GENDER. Press Enter after each selection to record the entry.
- The message area will next prompt for a user Fitness Level ("Do you participate in Aerobic Activity at least 20 minutes per session 3+ times per week"). Select 'YES' or 'NO'. Press ENTER to accept the selection.

The Air Force PRT begins after the user selects their Fitness Level and presses ENTER. During the PRT the user must maintain 50-80 RPM. If the user pedals outside this range, a warning message is displayed. If the user continues to pedal outside this range for more than 10 seconds, the test is terminated. If the user's heart rate exceeds 85% of their theoretical maximum heart rate, the test is also terminated. The Air Force PRT requires a user's heart rate throughout the test. Heart rate is recorded every minute, and if it is not detected, the test will terminate. The PRT starts with a 2 minute warm-up. After this warm-up, an initial wattage setting is determined from the user's input data. The PRT then monitors a user's heart rate and determines if more resistance is needed. After 6 minutes at a constant wattage, the exercise bike will try to calculate a score.

## **6) CUSTOM WORKOUTS**

These training programs are preset custom workouts created by the facility training professional. The workouts may be Level or Target Heart Rate workouts created for specific results. Each Custom Workout profile may be viewed by pressing the View key and then a Custom Workout button. A screen showing the interval and level profile for that Custom Workout will appear. Select Begin to start a workout using the displayed profile or select the back arrow to return to the Custom Workouts screen. Consult the facility training professional for details on individual Custom Workouts.

# 5 SYSTEM OPTIONS MENU

## 5.1 USING THE SYSTEMS OPTIONS MENU

Fitness club managers and other authorized personnel can use the Systems Options feature to change default settings, or to enable or disable certain programs or displays on the bike console, to run systems checks, and to access compiled statistics.

To enter the System Options, go to the Workout Selection Screen, press and hold the COOLDOWN key, and touch the Life Fitness icon twice consecutively (double-touch).

### SYSTEM TEST

Allows technicians to run systems diagnostics. **NOTE:** These tests should only be used by (or with the express instruction of) a trained Life Fitness service technician.

System Diagnostics	Telemetry Test
Lifepulse Test	CSAFE Network Test
EEPROM Test	

### INFORMATION

System usage statistics on main motor. Allows authorized personnel to access statistics on machine usage (Statistics and Usage Log). All other information is designed for use by trained Life Fitness service technicians.

Statistics	Software Versions
System Errors	Usage Log

### CONFIGURATION

Allows access to all of the configurable settings of the unit. Configurations which should only be changed by qualified technicians are password protected.

Manager	Touch Screen Configuration
Manufacturer (password protected)	TV / FM Radio (if detected)
Export / Import Settings	Clock

## 5.2 CONFIGURATION SETTINGS

### 1) MANAGER'S CONFIGURATION

Manager's Configuration accesses defaults for Workout Duration Configuration, Language, User Language, Program Timeout, Units (English or Metric), System Beeps, Pause Time, Marathon Mode, Custom Message Setup, and Stand By Configuration.

SETTING	DEFAULT	DESCRIPTION
LANGUAGE	ENGLISH	The language of the Message Center display. Choices include English, German, French, Italian, Japanese, Dutch, Spanish, Portuguese, Korean, Russian, Turkish, Traditional Chinese and Simplified Chinese.
USER LANGUAGE	OFF	This option, if enabled, gives users the ability to select a language for use during a workout. See the topic entitled <i>User Language</i> , in this section.
ENGLISH/METRIC UNITS	ENGLISH	The measurement unit type for weight and distance.
WORKOUT DURATION	60 (minutes)	This feature enables fitness club managers to set workout duration limits. See the topic Section 5.1, <i>Workout Duration Configuration</i> .
STANDBY CONFIGURATION	ON, 2(hours)	Inactivity Timer: Enables the LCD screen backlight to be turned off due to inactivity. See Section 5.1, <i>Standby Configuration</i> .
PAUSE TIME	1 (minute)	The amount of time the unit can be inactive before it reverts back to the Welcome Screen.
CUSTOM MESSAGE SETUP	ENABLED	See <i>Using the Custom Message Setup</i> in this section.
PROGRAM TIMEOUT	60 Seconds	The amount of time the user can go without touching the Touchscreen during workout setup, before the unit returns to the Welcome Screen

#### TO SET DEFAULTS

Either select appropriate radio buttons to select toggle settings, or use the arrow keys to modify variable default values. Select DEFAULTS to return all values to original factory settings.

**Maximum Workout Duration:** Allows the manager to set a maximum workout limit between 1 and 99 minutes. The time can be modified using the up or down arrow keys. The unit default is 60 minutes.

**Standby Configuration:** Sets the desired amount of time of inactivity before the system automatically turns the LCD screen backlight off. The LCD screen will illuminate the next time activity is detected. Inactivity Timer can be set from 0 to 24 hours.

**Program Timeout:** Sets the amount of time the user can go without touching the Touchscreen while setting up their workout, before the console resets back to the Welcome Screen. Program Timeout can be set from 20 to 255 seconds. The unit default is 60 seconds.

**Pause Time:** Set the amount of time the unit can be inactive before it reverts back to the Welcome Screen. Pause Time can be set from 1 to 99 minutes. The unit default is 1 minute.

**Units:** Choose between English and Metric.

**Language:** The language of the message area display. Choices include English, Portuguese, Spanish, Dutch, Japanese, Italian, French, and German.

## CUSTOM MESSAGES

**This configuration allows for a custom message to be displayed across the Welcome Screen.**

Creating/Changing a Custom Message — After entering the Manager's Configuration, check to make sure that Custom Message is enabled, then select CUSTOM MESSAGE SETUP. Upon entering the setup screen, a message can be entered using the on-screen keyboard. Use the Shift button to input special characters and capital letters. The message will scroll across the top of the screen as the message is being inputted giving real-time feedback.

Accepting a Custom Message — To accept the Custom Message, simply select the MAIN MENU button.

Erasing a Custom Message — To erase a Custom Message, enter the CUSTOM MESSAGE SETUP screen. Select CLEAR MESSAGE and then MAIN MENU.

## USER LANGUAGE

**To enable the User Language option, select the User Language button to enter the User Language Setup screen. Toggle the mode from disabled to enabled. Choose the languages to be available for user interaction.**

**After touching the Welcome Screen to begin, the User Language Selection screen will appear requesting the user to choose a language or select Quick Start to begin a workout. Selecting a language is not necessary to begin a workout. Simply press the Quick Start key to start a workout. The unit will return to the Welcome Screen if a language or Quick Start is not selected within the default program timeout period.**

The following languages are available:

English, German, French, Italian, Japanese, Dutch, Spanish, Portuguese, Korean, Russian, Turkish, Traditional Chinese, and Simplified Chinese.

## UNITS

**Toggle the default units displayed between English and Metric. Choose “User Selectable” to allow users to choose desired units on-screen during a workout.**

## MARATHON MODE

Marathon Mode has no preset or setable goal. It allows the user to workout indefinitely. If enabled, a workout in Marathon Mode ends only if the user chooses to end it.

## CUSTOM WORKOUTS

### 2) TV / FM RADIO (IF DETECTED)

Brings up TV / FM Radio configuration screen, which is used to set and customize TV and FM radio reception options.

#### TV Setup

Opens the TV Setup screen allowing adjustment of brightness, contrast, saturation, and hue. Also allows choice of TV format, antenna setup, and channel setup.

To Set Up Channels: select Channel Setup; Auto, Start.

Audio Only option: Allows only the TV audio to be heard. TV video is disabled.

To Delete an Unwanted Channel: Choose Channel Setup; Manual, use the Channel Controls to choose the channel to be deleted, select delete, return the Channel Setup to Auto.

To Restore a Channel: Choose Channel Setup, Manual; use the Channel Controls to choose the channel to be restored, select Add, return the Channel Setup to Auto.

To Adjust Picture Setup: Brightness, Contrast, Saturation, and Hue can be adjusted by using the corresponding arrow buttons. To return to the unit defaults, select Default.

Max Volume Setup: Opens the Max Volume controls. (Headphones must be used for this function.) The upper set of arrows adjusts the volume capacity higher or lower, allowing clubs to compensate for average noise levels within. The maximum volume returns to this default after each workout.

The Volume Down, Volume Up arrows control the volume of the unit for the current usage. After each session ends, the unit resets to a mid-range volume corresponding to the maximum volume set up.

**TV Format:** Opens the TV Format window. Choose the appropriate country, TV format (NTSC-M, PAL-I, PAL-B/G, SECAM-L), and Audio format (M-Korea, B/G FM, D/K1, D/K2, D/K Mono HDEV3, D/K3, B/G NICAM, L NICAM-AM, I NICAM, D/K NICAM, D/K NICAM HDEV2, D/K NICAM HDEV3, BTSC-Stereo) from the provided listings. Select OK to accept the settings.

**Frequency Tuning:** Opens the Frequency Tuning window. Allows channel scanning through all available frequencies beginning at 45 MHZ. Begin a scan by selecting Start. Scroll through found channels using the Channel Up and Down arrow keys on the screen.

Channels can be fine tuned using the arrow keys located below the Frequency Tuning Start button. Use the Channel Up and Down arrow keys to select a channel to fine tune. Press the Fine Tuning arrow keys to adjust the frequency for the best possible picture.

Select OK to accept channels.

### **TV CHANNEL FAVORITES**

Opens the Favorite Channel configuration screen. Up to 9 favorite channels can be stored for quick access during a workout. This feature may be enabled or disabled.

Note: Setting channels using the auto channel setup procedure, as instructed in TV Setup, is recommended before attempting to setup favorite channels.

To Set Up a Favorite Channel: Select (touch) the enable radio button, select the radio button next to the input slot desired, select Enter Name, input the channel name using the keyboard display, select OK to accept the channel name, select the desired channel using the Up or Down ARROW Keys. Continue as desired to set up to 9 favorite channels. Select OK to set the channels to memory.

### **TV CHANNEL NAME/SORT**

Opens the Channel Name / Sort configuration screen. Allows the facility manager to customize the TV channel list order. This feature may be enabled or disabled.

Note: Setting channels using the auto channel setup procedure, as instructed in TV Setup, is recommended before attempting to setup favorite channels.

To Set Up a Channel List item: Select (touch) the enable radio button, select the radio button next to the input slot desired, select Enter Name, input the channel name using the keyboard display, select OK to accept the channel name, select the desired channel using the Up or Down ARROW Keys. Continue as desired to set channel list. Select OK to set the channels to memory.

**Validation:** The validation checkbox enables or disables viewing of the channel in the list. Select the checkbox to enable the channel. If Channel Name / Sort and Channel Favorites are both enabled, channels not marked as valid (enabled) in Channel Name / Sort will be removed from Channel Favorites.

**Channel Swap:** To swap channels within the channel listing, select Channel Swap. Select the radio button next to the desired channel. The Channel Swap window will appear showing the channel selected for swapping. Use the Up or Down arrow keys to select the second channel to swap with the previous channel. Select the swap button to preview the channel swap information. Press OK to confirm the channel swap or Cancel to exit without swapping channels.

## **SECURE CHANNEL**

Opens the Secure Channel Setup screen. If enabled, one existing input channel can be selected to be a dedicated channel for non-broadcast use. Select the Channel Change button to scroll up or down to the desired channel. Select the Name Change button to input a name for the secure channel using the keyboard display.

If enabled, a password can be assigned to the channel further securing channel access.

## **PROMO CHANNEL SETUP**

Opens the Promo Channel Setup screen. If enabled, one existing input channel can be selected to be a dedicated channel for internal promotional broadcast use. Select the Channel Change button to scroll up or down to the desired channel.

### **ADVANCED PROMO CHANNEL SETTINGS**

When Promo Channel is enabled, the option becomes available to choose how Promo Channel may be configured when viewed in the attract screen.

If “Promo Channel Only” is selected, only the channel selected as the Promo Channel is available for display in the attract screen.

If “Allow User to Change Channel” is selected, users may change the channel displayed in the attract screen using the CHANNEL UP or DOWN arrow keys.

Within this option, the number of minutes before the TV display returns to the Promo Channel is set. Whether or not the unit starts up with the Promo Channel displayed can also be configured.

If “Start with Promo Channel” is not selected, the unit will startup and display the last channel selected by the user.

## **FM RADIO SETUP (IF TUNER IS DETECTED)**

Opens the FM Radio Setup screen. The FM Radio feature may be enabled or disabled. If enabled, this screen can be used to set up, delete or restore preset FM radio channels. Preset channels may be enabled or disabled. If enabled, the seek forward and back buttons can be used during a workout to select from available preset channels. If disabled, the seek forward and back buttons can be used during a workout to select from all available channels with sufficient signal strength for the tuner to detect.

To Set Up Channels: Select Channel Setup; Auto, Start.

To Delete an Unwanted Channel: Choose Channel Setup; Manual, use the Channel Controls to choose the channel to be deleted, select delete, return the Channel Setup to Auto.

To Restore a Channel: Choose Channel Setup; Manual, use the Channel Controls to choose the channel to be restored, select Add, return the Channel Setup to Auto.

## **3) CUSTOM WORKOUTS**

Brings up the custom workout configuration screen, which is used to edit any of the 6 custom workouts and to name the custom workout. Select the custom workout name to change the name of the custom workout. Select from two types of custom workouts: Level or Target Heart Rate. Level is selected if you want the workout level to change during the custom workout. The Target Heart Rate is selected if you want your Target Heart Rate goal to change during the custom workout. Select the workout time goal (total workout time) for your custom workout. Use the arrow keys at the right-hand side of the screen to change the value of the item (level or target heart rate percentage) for the given segment. The number of intervals is always 30. For Level workouts, the length of each interval equals the selected duration divided by 30. For Target Heart Rate workouts, you can have up to 30 different target heart rate goals. Once you reach the current segment's target heart rate goal the workout will activate the next segment's target heart rate goal.

For Level workouts, each interval is identified by the time at which it occurs during the workout. For target heart rate workouts, each interval is identified by a number (1 - 30). If Level is selected, a graph shows up displaying each interval. For Target Heart Rate workout one graph shows up displaying each interval. To change intervals use the arrow keys under the word Interval.

You can save your custom workout after editing by pressing the OK button. Press the Cancel button if you do not want to save the custom workout. Press the Clear Workout button to erase the custom workout.

#### **4) TOUCH SCREEN CONFIGURATION**

Follow the instructions on the screen to recalibrate the Touchscreen. When finished touch anywhere on the screen to return to the Main Menu.

#### **5) EXPORT / IMPORT SETTINGS**

Brings up the Export / Import Settings screen which is used to import or export manager and manufacturer configurable settings. This can be advantageous when many or all optional features are enabled and configured.

To Export Settings: Turn the unit off at the power switch. Remove the eight screws securing the front console to the rear. Carefully tilt the front console forward exposing the console circuit board.

Carefully insert a Compactflash<sup>TM</sup> card into the available slot. Carefully set the console front onto the rear console. Turn the unit on at the power switch. Enter the Export / Import Settings through the Configuration Menu. Select "Export Settings To Flash Card". Upon notification, turn the unit off at the power switch. Unplug the Compactflash<sup>TM</sup> card. Reposition the front console onto the rear console and secure them together using the eight previously removed screws. Turn the unit on at the power switch.

To Import Settings: Turn the unit off at the power switch. Remove the eight screws securing the front console to the rear. Carefully tilt the front console forward exposing the console circuit board.

Carefully insert a Compactflash<sup>TM</sup> card into the available slot. Carefully set the console front onto the rear console. Turn the unit on at the power switch. Enter the Export / Import Settings through the Configuration Menu. Select "Import Settings From Flash Card". Upon notification, turn the unit off at the power switch. Unplug the Compactflash<sup>TM</sup> card. Reposition the front console onto the rear console and secure them together using the eight previously removed screws. Turn the unit on at the power switch.

**NOTE:** It is important to turn the unit off before inserting or removing the Compactflash<sup>TM</sup> card.

**NOTE:** Exported setting information is product specific. Treadmill settings can only be imported into other, same model treadmills. Treadmill settings cannot be used to update settings of any other product.

**NOTE:** This method is not recommended for the setup of basic TV or FM channels. See TV Setup or FM Radio Setup to set basic channel configuration.

# 6 SERVICE AND TECHNICAL DATA

## 6.1 PREVENTIVE MAINTENANCE TIPS

The Lifecycle Upright Bike is backed by the engineering excellence of Life Fitness and is one of the most rugged and trouble-free pieces of exercise equipment on the market today. Commercial Life Fitness products have proven to be durable in health clubs, colleges, and military facilities the world over. This same technology, engineering expertise, and reliability have gone into the Lifecycle Upright Bike.

**NOTE:** The safety of the equipment can be maintained only if the equipment is examined regularly for damage or wear. Keep the equipment out of use until defective parts are repaired or replaced. Pay special attention to parts that are subject to wear as outlined in the Preventive Maintenance Schedule. See Section 6.2.

**REMARQUE :** pour conserver un matériel sûr, il convient de l'inspecter régulièrement afin de détecter tout signe d'usure ou d'endommagement. N'utilisez pas l'appareil tant que les pièces défectueuses n'ont pas été réparées ou remplacées. Portez une attention toute particulière aux pièces qui s'usent, comme indiqué ci-dessous.

The following preventive maintenance tips will keep the Lifecycle Upright Bike operating at peak performance:

- Locate the bike in a cool, dry place.
- Keep the pedal straps fastened securely when using the bike.
- Keep the display console free of fingerprints and salt build-up caused by sweat.
- Use a **100% cotton cloth**, lightly moistened with water and mild liquid detergent, to clean the bike. Other fabrics, including paper towels, may scratch the surface.  
**Do not use ammonia or acid-based cleaners.**
- Long fingernails may damage or scratch the surface of the console; use the pad of the finger to press the selection buttons on the console and touchscreen.
- Clean the housing thoroughly on a regular basis.

**NOTE:** A non-abrasive cleaner and soft cotton cloth are strongly recommended for cleaning the exterior of the unit. At no time should cleaner be applied directly to any part of the equipment; apply the non-abrasive cleaner on a soft cloth, and then wipe the unit.



## 6.2 PREVENTIVE MAINTENANCE SCHEDULE

Follow the schedule below to ensure proper operation of the product.

ITEM	WEEKLY	MONTHLY	BI-ANNUALLY	ANNUALLY
<i>Display Console</i>	Clean	Inspect		
<i>Console Mounting Bolts</i>			Inspect	
<i>Accessory Tray</i>	Clean	Inspect		
<i>Frame</i>	Clean			Inspect
<i>Plastic Covers</i>	Clean	Inspect		
<i>Pedals and Straps</i>	Clean	Inspect		

## 6.3 TROUBLESHOOTING THE LIFEPULSE SYSTEM SENSORS

If the heart rate reading is erratic or missing, do the following:

- Dry moist hands to prevent slipping.
- Grasp all four sensors, two in each hand.
- Grasp the sensors firmly.
- Apply constant pressure around the sensors.
- Clean the sensors with a damp cloth.

## 6.4 TROUBLESHOOTING THE POLAR HEART RATE CHEST STRAP

### HEART RATE READING IS ERRATIC, ABNORMALLY ELEVATED, OR ABSENT ENTIRELY

Malfunction	Probable Cause	Corrective Action
Heart rate reading is erratic or absent entirely	Belt transmitter electrodes are not wet enough to pick up accurate heart rate readings.	Wet the belt transmitter electrodes (see section 3.2).
	Belt transmitter electrodes are not laying flat against the skin.	Ensure the belt transmitter electrodes are laying flat against the skin (see section 3.2).
	Belt transmitter needs cleaning.	Wash the belt transmitter with mild soap and water.
	Belt transmitter is not within 3 feet (one meter) of the heart rate receiver.	Make sure the chest strap transmitter is within three feet (one meter) of the heart rate receiver.
	Chest strap battery is depleted.	Contact Life Fitness Customer Support Services* for instructions on how to have the chest strap replaced.
Abnormally elevated heart rate readings	Electromagnetic interference from television sets and/or antennas.	Move the treadmill a few inches away from the probable cause, or move the probable cause a few inches away from the treadmill, until the heart rate readings are accurate.
	Electromagnetic interference from cell phones.	
	Electromagnetic interference from computers.	
	Electromagnetic interference from cars.	
	Electromagnetic interference from high voltage power lines.	
	Electromagnetic interference from motor driven exercise equipment.	
	Electromagnetic interference from another heart rate transmitter within three feet (one meter).	

## 6.5 HOW TO OBTAIN PRODUCT SERVICE

1. Verify the symptom and review the operating instructions. The problem may be unfamiliarity with the product and its features and workouts.
2. Locate and document the serial number of the unit. This number consists of three letters followed by six numbers. The serial number label is located on the front stabilizer at the bottom of the unit.
3. Contact Life Fitness Customer Support Services via the Web at: [www.lifefitness.com](http://www.lifefitness.com), or call the nearest Life Fitness Customer Support Services group:

For Product Service within  
the United States and Canada:

Telephone: (+1) 847.451.0036  
FAX: (+1) 847.288.3702  
Toll-free telephone: 800.351.3737

For Product Service Internationally:

*Life Fitness Europe GmbH*  
Telephone: (+49) 089.317.751.66  
FAX: (+49) 089.317.751.38

*Life Fitness (UK) LTD*  
Telephone: (+44) 1353.665.507  
FAX: (+44) 1353.666.719

*Life Fitness Atlantic BV (Europe, Middle  
East & Africa except local Life Fitness  
offices)*

*Life Fitness Benelux*  
Telephone: (+31) 180.646.666  
FAX: (+31) 180.646.699

*Life Fitness Italia S.R.L.*  
Telephone: 800.438.836  
FAX: (+39) 0457.238.197

*Life Fitness Austria Vertriebs GmbH*  
Telephone: (+43) 1615.7198  
FAX: (+43) 1615.7198.20

*Life Fitness Asia Pacific Ltd (Asia &  
Australia, except local Life Fitness offices)*  
Telephone: (+852) 2891.6677  
FAX: (+852) 2575.6001

*Life Fitness Latin America  
and Caribbean*  
Telephone: (+1) 847.288.3964  
FAX: (+1) 847 288.3886

*Life Fitness do Brazil*  
Telephone (+55) 11.4193.8282  
FAX: (+55) 11.4193.8283

*Life Fitness Japan*  
Telephone: (+81) 3.3359.4309  
FAX: (+81) 3.3359.4307

*Life Fitness Iberia (Spain)*  
Telephone : (+34) 93.672.4660  
FAX : (+34) 93.672.4670

# 7 SPECIFICATIONS

## 7.1 95CE LIFECYCLE UPRIGHT EXERCISE BIKE SPECIFICATIONS

Designed use:	Heavy/Commercial
Maximum user weight:	400 pounds / 181 kilograms
Upper Touchscreen:	12.1 in. Diagonal, 800 x 600 TFT LCD
Channel coverage:	VHF: 2-13/UHF: 14-69/CATV: 1-125
Antenna:	75-ohm external antenna terminal for VHF/UHF (>43dBuV (@75ohm) or > 65.8dBm)
Headphone Jack:	300 milliwatt, 3.5mm Stereo
Broadcast Capabilities:	NTSC tuner supports NTSC-Japan, NTSC-HRC, NTSC-M, PAL-M and PAL-N. PAL/SECAM tuner supports PAL B/G, PAL-I, PAL-D/K, SECAM-L and SECAM-D/K.
Control Panel:	Arrow keys, screen lock and unlock, Cooldown, Quick Start, and TV controls.
Screens:	Workout Selection, Workout Setup and Workout Progress Screens
Information Displayed:	Distance, Mode (Bike or Constant Calories, CAL/HR), Calories, CAL/HR, *Watts, METs, Elapsed Time (or Remaining Time, or Hidden Time), Time in Zone, Level, RPM, and Target Heart Rate (for heart workouts), TV (on, zoom).
Summaries:	Total elapsed time of workout, total calories burned, total distance, and time in zone (when applicable.)
Workouts:	Quick Start, Fat Burn, Manual, Random, Cardio, and Hill Zone Training including: Heart Rate Hill, Heart Rate Interval, and Heart Rate Extreme. Hill Plus including: Around the World, Foothills, Kilimanjaro, Interval, Cascades, and Speed Training. Personal Trainer including: Watts, METs, Aerobics Trainer, Life Fitness Fit Test and Air Force PRT.
Heart rate monitor:	Lifepulse system sensors and Polar telemetry heart rate monitoring system. Polar heart rate chest strap (optional)
Intensity levels:	26 (0 to 25)
Pedal size	5 inches x 5.5 inches / 127 millimeters x 140 millimeters
Drive type:	Belt/alternator
Power Requirements:	Refer to Section 1.3 - <i>Setup, Electrical Power Requirements</i>
Accessory Tray:	Standard
Color:	Gray / Silver
Ports (1):	Type RJ45 Network ready connection
CATV (1):	F-type connector

### ASSEMBLED DIMENSIONS:

Length	54 inches / 137 centimeters
Width	26 inches / 66 centimeters
Height	51 inches / 129 centimeters
Weight	134 pounds / 61 kilograms

### SHIPPING DIMENSIONS:

	<b>Base</b>	<b>Console</b>
Length	57 inches / 145 centimeters	Length 19 inches / 48.25 centimeters
Width	29 inches / 74 centimeters	Width 24 inches / 61 centimeters
Height	44 inches / 112 centimeters	Height 8 inches / 20.3 centimeters
Weight	165 pounds / 75 kilograms	Weight 15 pounds / 6.8 kilograms



M051-00K63-B124