

IVB 3-H/5-H/7-H



Operating Instructions
Betriebsanleitung
Notice d'utilisation
Gebruiksaanwijzing
Istruzioni sull'uso
Driftsinstruks
Bruksanvisning

Driftsvejledning
Käyttöohje
Navodilo za uporabo
Uputstvo za rad
Prevádzkový návod
Provozní návod
Instrukcja obsługi

Kezelési utasítás
Руководство по эксплуатации
Instrucciones de manejo
Instruções de operação
Οδηγίες λειτουργίας
İşletme kılavuzu

IVB 3-H

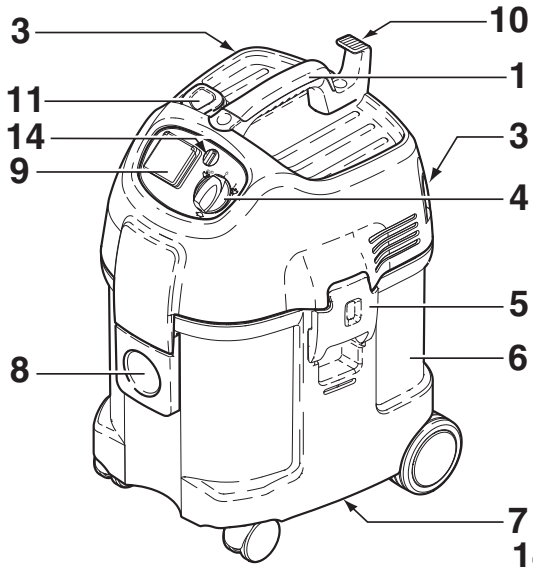

IVB 5-H

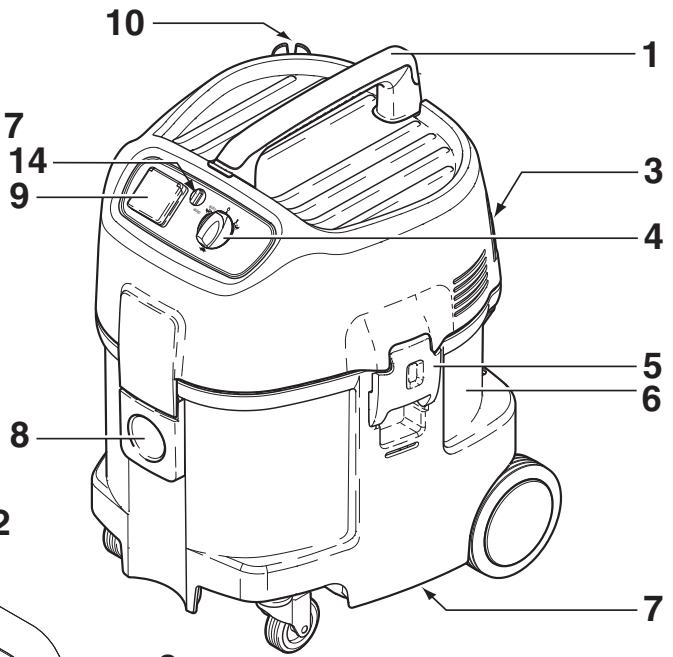

IVB 7-H

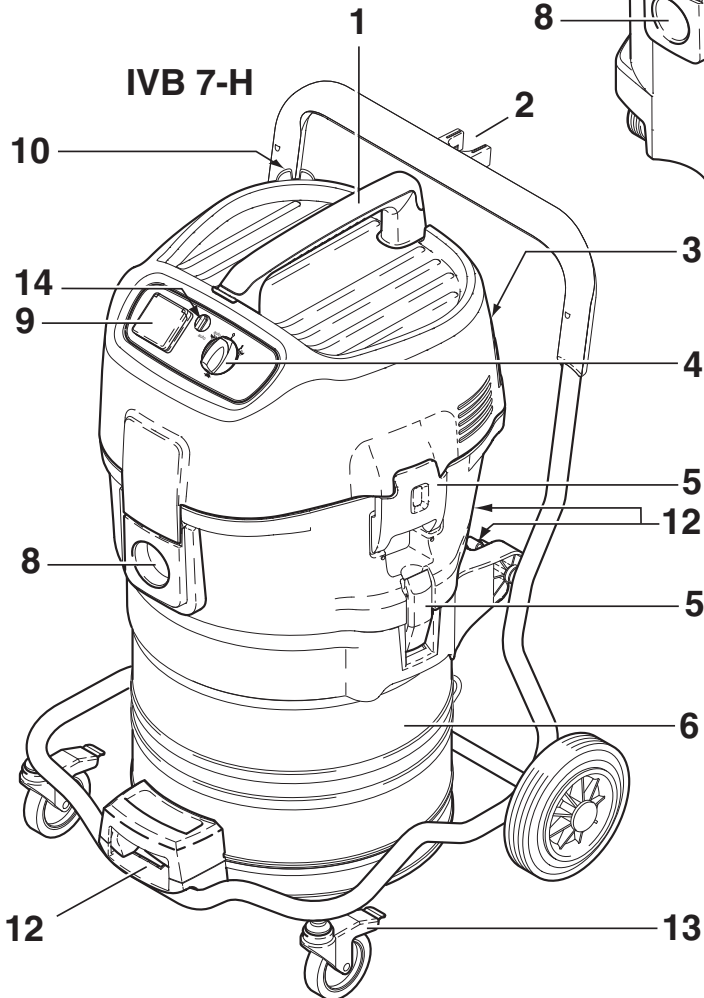

Contents

1 Important safety instructions	2
2 Description	2.1 Purpose.....	5
	2.2 Operating elements.....	5
3 Before start-up	3.1 Assembling the cleaner.....	6
4 Operation	4.1 Connections.....	6
	4.1.1 Connecting the suction hose.....	6
	4.1.2 Electrical connection.....	6
	4.1.3 Connecting electrical appliances.....	7
	4.2 Switching on the vacuum cleaner.....	7
	4.2.1 Switch position "I".....	7
	4.2.2 Switch position „auto“.....	7
	4.2.3 Suction power control.....	7
	4.3 Check volume flow monitor.....	7
	4.4 Acoustic warning.....	8
	4.5 Cleaning the filter element (IVB 3-H).....	8
	4.6 Cleaning the filter element (IVB 5-H/7-H).....	8
5 Applications and techniques	5.1 Techniques.....	9
	5.1.1 Picking up dry substances.....	9
	5.1.2 Picking up liquids.....	9
6 After finishing work	6.1 Switching the vacuum cleaner off and storage.....	10
7 Maintenance	7.1 Maintenance plan.....	10
	7.2 Maintenance work.....	11
	7.2.1 Replacing the waste bag.....	11
	7.2.2 Replacing the filter bag.....	11
	7.2.3 Replacing filter element „H“ (IVB 3-H).....	12
	7.2.4 Replacing filter element „H“ (IVB 5-H/7-H).....	12
	7.2.5 Emptying dirt tank (IVB 3-H/5-H).....	13
	7.2.6 Emptying dirt tank (IVB 7-H).....	13
8 Troubleshooting	14
9 Further information	9.1 Recycling the vacuum cleaner.....	15
	9.2 Guarantee.....	15
	9.3 Tests and approvals.....	15
	9.4 Technical data.....	16
	9.5 Accessories.....	16
	9.6 EC declaration of conformity.....	16

1 Important safety instructions

Symbols used to mark instructions



ily available.

Before using the vacuum cleaner, always read the operating instructions and keep them read-



to the vacuum cleaner and its performance.

This symbol is used to mark safety instructions that must be observed to prevent damage



damage to persons.

This symbol is used to mark safety instructions that must be observed to prevent



operation.

This symbol indicates tips and instructions to

For your own safety

Only allow the vacuum cleaner to be used by persons who have been trained in its use and who have been explicitly authorized to use it.

Despite its simple handling the vacuum cleaner is not suitable for children.

The use of the vacuum cleaner is subject to valid national regu-

lations. Besides the operating instructions and the binding accident prevention regulations valid in the country of use, observe recognized regulations for safety and proper use.

Do not use any unsafe work techniques.

Purpose and intended use

The vacuum cleaners described in this operating manual are suitable for

- commercial use, e.g. in hotels, schools, hospitals, factories, shops, offices and rental businesses.
- for separation of any kind of dust with exposure limits, including carcinogenic dust and hazardous dust (dust class H).

Permanent filters should be replaced by a specialist only in suitable rooms (e.g. contamination stations).

The following materials should not be picked up by the vacuum cleaner:

- hot materials (burning ciga-

rettes, hot ash, etc.)

- flammable, explosive, aggressive liquids (e.g. petrol, solvents, acids, alkalis, etc.)
- flammable, explosive dust (e.g. magnesium or aluminium dust, etc.)

When dust removers are used, the rate at which air is exchanged in the room must be adequate if the exhaust air from the vacuum cleaner is blown into the room (please observe regulations valid in your country).

Before starting work, the operating staff must be informed on

- use of the vacuum cleaner
- risks associated with the material to be picked up
- safe disposal of the picked up material.



Dust Class H (high). The dusts which belong to this class are: dusts with OEL values, all carcinogenic dusts and dusts which are mixed with pathogenic agents. Vacu-

ums for Dust Class H are tested in their entirety and have a maximum degree of permeability of 0.005%. The disposal must be dust free.

Precautions and safety regulations when using the vacuum cleaner

Before start-up

Inspect power cord regularly to detect signs of damage, e.g. cracks or ageing.

If the power cord is damaged, it must be replaced by Nilfisk-Advance-Service or an electrician to avoid danger before use of the vacuum cleaner is continued.

Use only the type of power cord specified in the operating manual.

Do not damage the power cord (e.g. by moving over it or pulling or crushing it).

Disconnect the power cord by pulling the plug only (do not pull or tug the power cord).

Inspect the vacuum cleaners to ensure that they are in proper condition. Plugs and couplings in power cords must at least have splash protection.

Never use the vacuum cleaner if the filter element is damaged.

Picking up liquids

If foam develops or liquid emerges, stop work immediately and empty the dirt tank.

Regularly clean the built in float (IVB 3-H) and level indicator hose (IVB 5-H/7-H) to limit the water level and check that they are not damaged.

See section 5 for information on handling liquids and (hazardous) dust.

Electrical components

Check the rated voltage of the vacuum cleaner before connecting it to the mains supply system. Ensure that the voltage shown on the rating plate corresponds to the voltage of the local mains power supply.

If you are using an extension cord, use only those specified by the manufacturer or higher quality ones (see section 9.4 „Technical data“).

It is recommended that the vacuum cleaner should be connected via a residual current circuit breaker. This stops the supply of electricity if the leakage current to earth exceeds 30 mA for 30 ms or it has an earth tester circuit.

When using an extension lead, check the minimum cross-sections of the cable:

Cable length m	Cross section	
	<16 A	<25 A
up to 20 m	ø1.5mm ²	ø2.5mm ²
20 to 50 m	ø2.5mm ²	ø4.0mm ²

Arrange the electrical parts (sockets, plugs and couplings) and lay down the extension lead so that the protection class is maintained.

Never spray water on to the upper section of the vacuum cleaner. Danger for persons, risk or short-circuiting.

Observe the latest edition of the IEC regulations.

Tool socket

Use the socket on the vacuum cleaner for the purpose defined in the operating instructions only.

Before plugging an appliance into the appliance socket:

1. Switch off the vacuum cleaner

2. Switch off the appliance to be connected.

CAUTION!

Follow the operating instructions and safety instructions for appliances connected to the power tool socket.

Maintenance, cleaning and repair

Only carry out maintenance work described in the operating instructions.

Always pull out the mains plug before cleaning and maintenance of the vacuum cleaner.

During maintenance and cleaning, handle the vacuum cleaner in such a manner that there is no danger for maintenance staff or other persons.

In the maintenance area

- use filtered compulsory ventilation
- wear protective clothing
- clean the maintenance area so that no harmful substances get into the surroundings.

Before removing the vacuum cleaner from the area contaminated with harmful substances:

- clean the outside of the vacuum cleaner, wipe it clean or

- pack the vacuum cleaner in well sealed packaging
- and avoid spreading deposited harmful dust.

During maintenance and repair work all contaminated parts that could not be cleaned satisfactorily must be:

- packed in well sealed bags
- disposed of in a manner that complies with valid regulations for such waste removal.

A dust test must be performed at least once every year by Nilfisk-Advance service or a trained person. This test includes, for example, whether there is damage to the filter, the vacuum cleaner is sealed to the air and the control equipment works properly.

Accessories and spare parts

Use only the brushes supplied with the vacuum cleaner or specified in the operating manual. The use of other brushes can adversely affect safety.

Use only original Nilfisk-Advance accessories and spare parts (see section 9.5). The use of other parts can adversely affect safety.

2 Description

2.1 Purpose

The vacuum cleaners IVB 3-H/IVB 5-H/IVB 7-H are suitable to pick up dry, nonflammable dust, nonflammable liquids, sawdust and hazardous dusts with maximum room concentration values, carcinogenic dusts and other dusts containing germs (dust class H).

To pick up dust with maximum room concentration values use the filter bag.

To pick up harmless dust use the waste bag. See section 9.5 "Accessories" for ordering number.

2.2 Operating elements

See fold-out page at the front of these operating instructions.

- | | |
|---|---|
| 1 Handle | 7 Grip to empty tank ¹⁾ |
| 2 Suction pipe support | 8 Inlet fitting |
| 3 Accessory holder | 9 Appliance socket |
| 4 Appliance switch with suction power control | 10 Cable hook |
| 5 Retaining clamp | 11 Operating knob for filter cleaning ¹⁾ |
| 6 Dirt tank | 12 Tank locks |
| | 13 Castor with brake |
| | 14 Hose diameter setting |

¹⁾ Option depending on model

3 Before start-up

3.1 Assembling the cleaner

CAUTION!

On delivery some of the accessories are lying in the tank and must be removed before the vacuum cleaner is used for the first time. Remove the upper section of the vacuum cleaner: The mains plug should not be inserted into a socket.

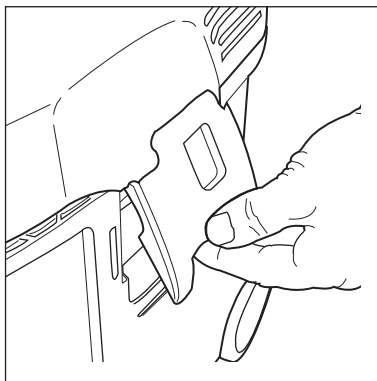

1. Open the retaining clamps and lift off the upper section of the cleaner.
2. Take the accessories out of the dirt tank and the packaging.
3. To pick up dust with maximum room concentration values: Insert the filter bag into the dirt tank according to the instructions (instructions included).
To pick up harmless dust: Insert the disposal bag (instructions included) into the tank.
IMPORTANT: Press the filter bag connection firmly on to the inlet fitting.
4. Fit the upper section of the vacuum cleaner and close the retaining clamps.
NOTE: Ensure that the retaining clamps fit properly.

4 Operation

4.1 Connections

4.1.1 Connecting the suction hose

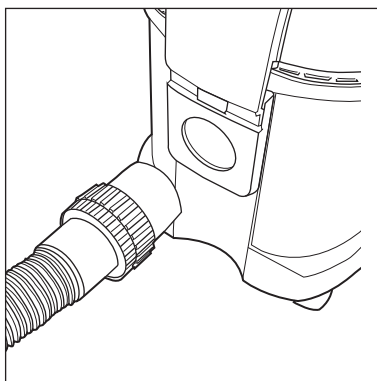

1. Connect the suction hose.

The suction hose diameter must suit the position of the switch in order to pick up dry, nonflammable dust with maximum room concentration values.

4.1.2 Electrical connection

The operating voltage shown on the rating plate must correspond to the voltage of the mains power supply.

1. **Ensure that the vacuum cleaner is switched off.**
2. Insert the power cord into a properly installed and fused socket with an earthing contact.

4.1.3 Connecting electrical appliances

To comply with regulations, only approved dust producing tools should be connected.

The maximum power consumption of the connected power tool is stated in section 9.4 "Technical data".

1. Ensure that the electrical appliance is switched off.
2. Connect the electrical appliance to the appliance socket on the control panel.

4.2 Switching on the vacuum cleaner

4.2.1 Switch position "I"

The hose diameter and the setting for the suction hose diameter must be the same.

Hose \varnothing	Hose diameter setting
$\varnothing 27$	$\varnothing 27$
$\varnothing 32$	$\varnothing 32$
$\varnothing 38$	$\varnothing 38$
$\varnothing 50$	$\varnothing 50$

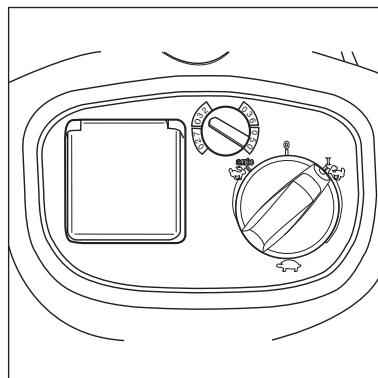

1. Turn the switch to position „I“.
- The vacuum cleaner motor starts.

4.2.2 Switch position „auto“

The hose diameter and the setting for the suction hose diameter must be the same.

Hose \varnothing	Hose diameter setting
$\varnothing 27$	$\varnothing 27$
$\varnothing 32$	$\varnothing 32$
$\varnothing 38$	$\varnothing 38$
$\varnothing 50$	$\varnothing 50$

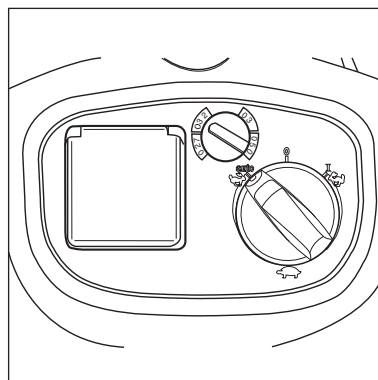

Before switching the switch to position „auto“, ensure that the tool connected to the appliance socket is switched off.

1. Turn the switch to position „auto“. The vacuum cleaner motor starts when the connected appliance is switched on.
2. When the power tool is switched off the vacuum cleaner continues to run for a short moment so that any dust in the suction hose is conveyed to the safety filter bag.

4.2.3 Suction power control

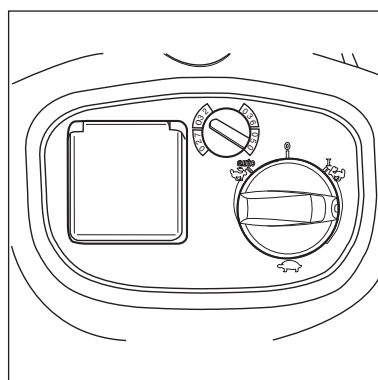

The motor speed and the suction power can be varied with the suction power control. This allows precise adaptation of the suction power for different cleaning tasks.

4.3 Check volume flow monitor

Before picking up dust with maximum room concentration values:

1. Check that all the filters are present and properly fitted.
2. When the motor is running, hold the suction hose shut. An acoustic warning sounds after approx. 1 second.

4.4 Acoustic warning

For safety reasons, an acoustic warning sounds if the air speed in the suction hose drops to below 20 m/s. See section “Troubleshooting”.

4.5 Cleaning the filter element (IVB 3-H)

NOTE:

If the acoustic signal sounds again after repeated cleaning, replace the filter element (see section 7.2.3).

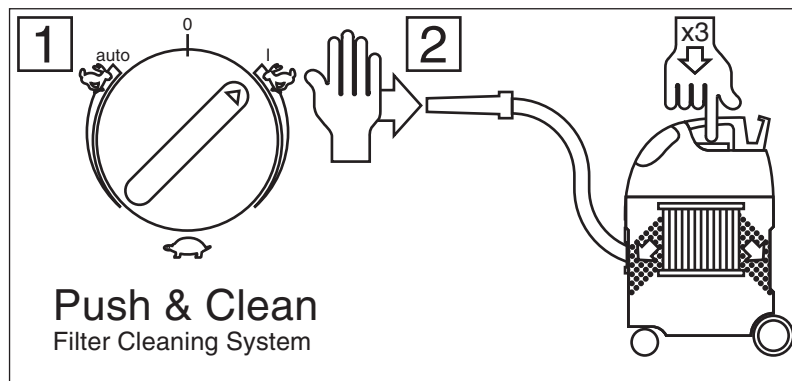

*Only after picking up harmless dust using the waste bag.
 If suction performance drops:*

1. Set the suction power to maximum.
2. Close the nozzles or suction hose opening with the palm of your hand.
3. Press the button to start filter

cleaning three times. The resulting stream of air removes attached dust from the slats of the filter elements.

4.6 Cleaning the filter element (IVB 5-H/ IVB 7-H)

To ensure that suction performance is always at its best, the filter element is automatically cleaned during operation. We recommend complete cleaning if the filter element becomes extremely dirty.

NOTE:

If the acoustic signal sounds again after repeated cleaning, replace the filter element (see section 7.2.4).

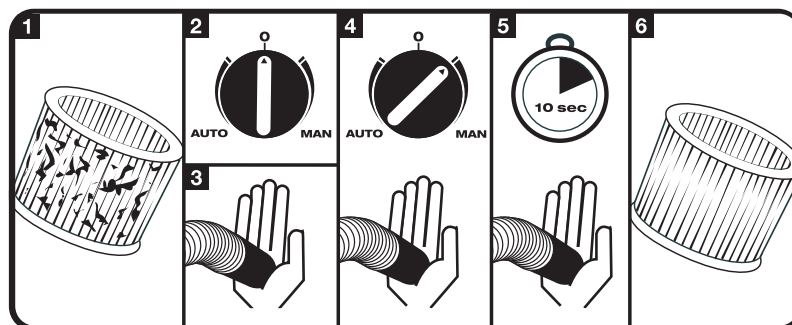

Only after picking up harmless dust using the waste bag.

1. Switch off the vacuum cleaner
2. Close the nozzles or suction hose opening with the palm of your hand.

3. Turn the switch to position „I“ and let the cleaner operate for approx. 10 seconds with the suction hose opening closed.

5 Applications and techniques

5.1 Techniques

If used correctly, additional accessories, suction nozzles and suction hoses can enhance the cleaning action and reduce the cleaning effort.

Effective cleaning is achieved if you follow just a few guidelines in combination with your own practical experience in special fields.

Here are some basic tips.

5.1.1 Picking up dry substances

CAUTION:
Do not pick up flammable substances.

ries” for ordering number. Disposal of the picked up material is then simple and hygienic.

The suction hose diameter must suit the position of the switch in order to pick up dry, nonflammable dust with maximum room concentration values.

After picking up liquids, the filter element is wet. A damp filter element clogs more quickly when dry substances are picked up. For this reason the filter element should be washed and dried or replaced by a dry element before dry substances are picked up.

There must always be a safety filter bag in the tank before dry substances with maximum room concentration values are picked up. See section 9.5 “Accessories” for ordering number.

To pick up harmless dust we recommend the use of a waste bag. See section 9.5 “Accesso-

5.1.2 Picking up liquids

CAUTION:
Do not pick up flammable substances.

The use of a separate filter element or filter screen is recommended.

Before liquids are picked up, always remove the filter bag/waste bag and check that the float (IVB 3-H) or the water level limit (IVB 5-H/7-H) works properly. (See section 7.2.3 and 7.2.4 “Replacing the filter element“.)

If foam appears, stop work immediately and empty the tank.

To reduce the amount of foam, use foam killer Nilfisk-Advance Foam Stop (see section 9.5 „Optional Accessories“ for order number).

6 After finishing work

6.1 Switching the vacuum cleaner off and storage

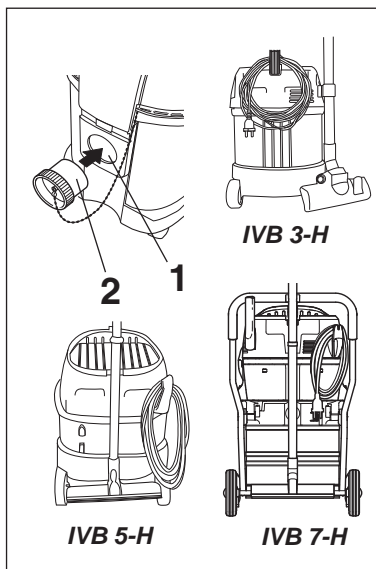

1. After picking up hazardous dust, vacuum clean the outside of the cleaner.
2. Switch off the vacuum cleaner and pull the mains plug out of the socket.
3. Remove the suction hose from the vacuum cleaner and close the inlet fitting (1) with the plug (2).
4. Wind up the power cord and hang it on the handle.
5. Empty the tank and clean the vacuum cleaner.
6. After picking up liquids: Store the upper section of the cleaner separately so that the filter element can dry.
7. Store the vacuum cleaner in a dry room where it is protected from unauthorized use.

7 Maintenance

7.1 Maintenance plan

		After finishing work	As required
7.2.1	Replacing the waste bag		●
7.2.2	Replacing the safety filter bag		●
7.2.3	Replacing filter element „H“ (IVB 3-H)		●
7.2.4	Replacing filter element „H“ (IVB 5-H/7-H)		●
7.2.5	Emptying dirt tank (IVB 3-H/IVB 5-H)	●	
7.2.6	Emptying dirt tank (IVB 7-H)	●	

7.2 Maintenance work

7.2.1 Replacing the waste bag

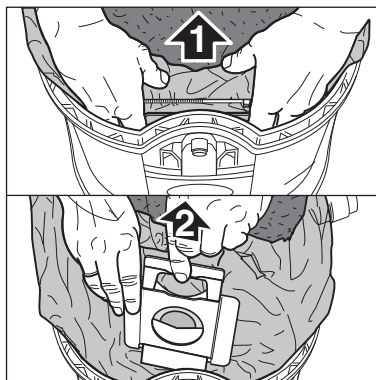

Only after picking up harmless dust.

IVB 3-H/IVB 5-H:

1. Open the retaining clamps and remove the upper section of the cleaner from the dirt tank.
2. Carefully remove the waste bag connection (1) from the inlet fitting.
3. Close the waste bag connection with the slide (2).
4. Close the waste bag using the cable binder (3).

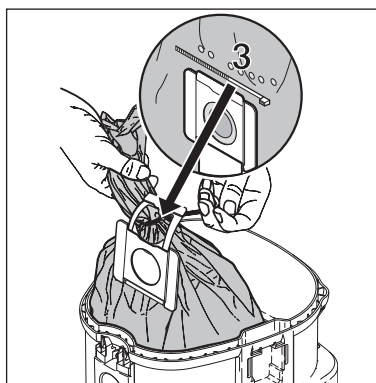

5. Dispose of the dirt in accordance with legal regulations.
6. Insert a new filter bag into the cleaned tank as described in the instructions enclosed.

IMPORTANT:

Press the filter bag connection firmly on to the inlet fitting.

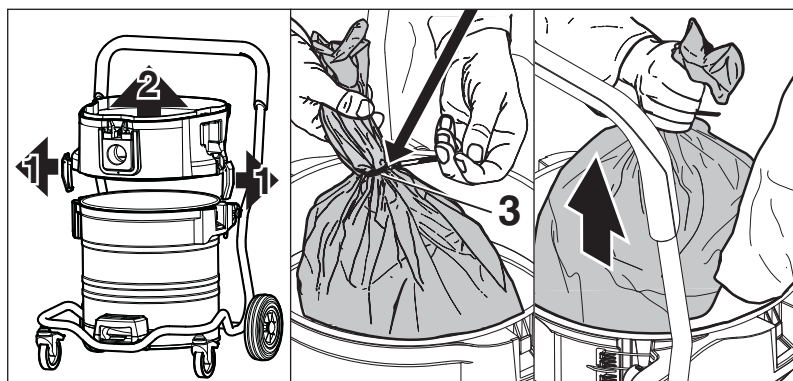

IVB 7-H:

1. Remove the upper section of cleaner from the dirt tank.
2. Open the retaining clamps (1) and remove the intermediate ring (2) from the tank.
3. Close the waste bag using the cable binder (3).
4. Dispose of the dirt in accordance with legal regulations.
5. Insert a new filter bag into the cleaned tank as described in the instructions enclosed.

IMPORTANT: Press the filter bag connection firmly on to the inlet fitting.

7.2.2 Replacing the safety filter bag

During the following work, ensure that dust is not unnecessarily spread around. Wear a P2 breathing mask.

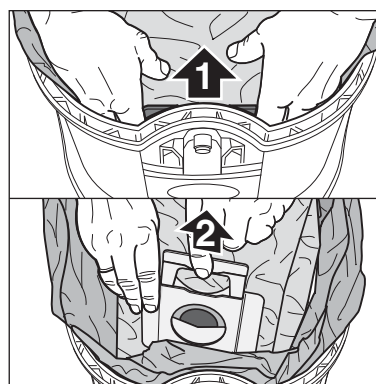

1. Clean the filter element (see 4.5 and 4.6).
2. Switch off the vacuum cleaner and wait approx. 5 minutes so that the dust can settle in the tank.
3. Open the retaining clamps and remove the upper section of the cleaner from the dirt tank.
4. Remove the filter bag connection (1) from the inlet fitting.
5. Close the safety filter bag connection (2) with the slide.
6. Remove the plastic sleeve from the tank rim and close it using a cable binder (3).
7. Remove the safety filter bag from the tank and dispose of it in accordance with legal regulations.
8. Insert a new safety filter bag into the tank according to the instructions (in the filter bag packaging).

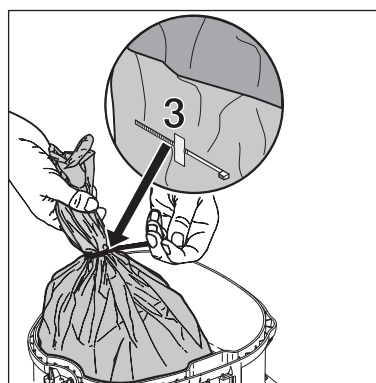

IMPORTANT:

Press the filter bag connection on the inlet fitting as far as possible.

7.2.3 Replacing filter element „H“ (IVB 3-H)



During the following work, ensure that dust is not unnecessarily spread around. Wear a P2 breathing mask.

Never use the vacuum cleaner without a filter.

1. Clean the filter element (see 4.5).
2. Switch off the vacuum cleaner and wait approx. 5 minutes so that the dust can settle in the tank.

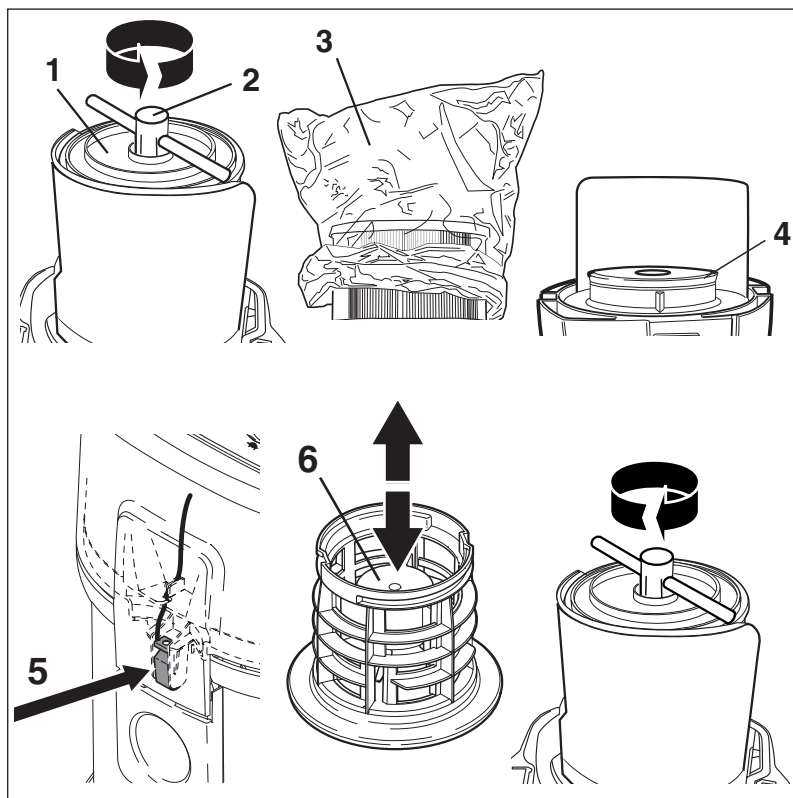

3. Open the retaining clamps and remove the upper section of the cleaner from the dirt tank. Lay the upper section of the cleaner down with the filter element facing upwards.
4. Using the enclosed tool (2), turn the filter holder (1) anticlockwise and remove it.
5. Place the protective filter bag over the filter element (3).
6. Carefully remove the filter element and close the protective filter bag with a knot.
7. Clean the filter seal (4). Check it for damage and replace it if necessary.
8. Check the antistatic clamp (5) for damage and have it replaced by Nilfisk-Advance Service if necessary.
9. Fit a new filter element.
10. Check that the float (6) works properly. When the filter holder is turned, the float inside must move about easily.
11. Using the enclosed tool, attach the filter holder and turn it clockwise to lock it.
12. Dispose of the used filter element in accordance with legal regulations.

7.2.4 Replacing filter element „H“ (IVB 5-H/7-H)



During the following work, ensure that dust is not unnecessarily spread around. Wear a

P2 breathing mask.

Never use the vacuum cleaner without a filter.

1. Remove the upper section of cleaner from the dirt tank. Lay the upper section of the

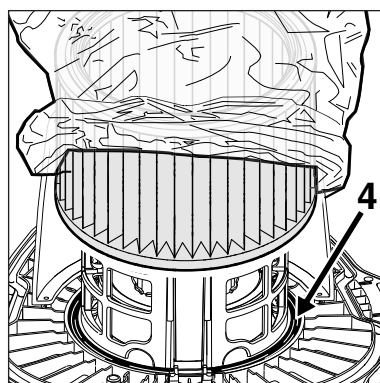
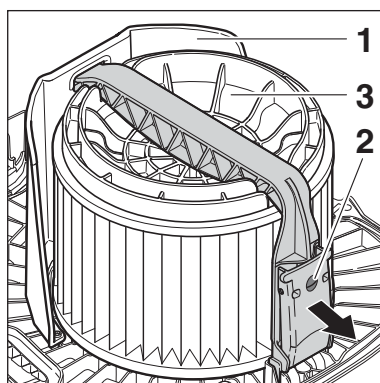

- cleaner down with the filter element facing upwards. Do not place the upper section of the cleaner on the guard (1) and do not damage the filter element.
2. Unscrew the screw (2), open the bar handle and remove it.
3. Remove the filter holder (3).
4. Place the protective filter bag over the filter element.
5. Carefully remove the filter element and close the protective filter bag with a knot.
6. Clean the filter seal (4). Check it for damage and replace it if necessary.
7. Check the antistatic clamp (5) for damage and have it replaced by Nilfisk-Advance Service if necessary.

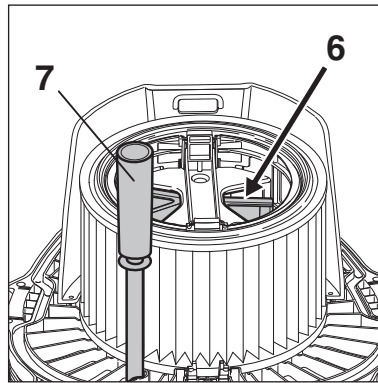
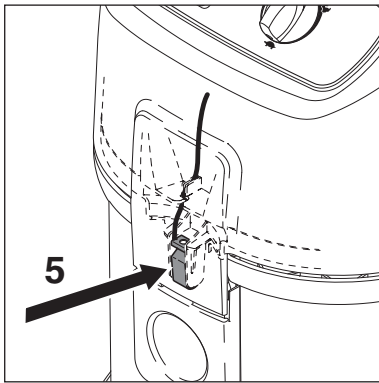

8. Check that the control flap (6) for filter cleaning works properly. The control flap should move back and forwards easily.
9. Clean the level hose (7).
10. Fit a new filter element.
11. Fit the filter holder. Ensure that it is in the correct position.
12. Fit bar and close bar handle.
13. Dispose of the used filter element in accordance with legal regulations.

7.2.5 Emptying dirt tank (IVB 3-H/IVB 5-H)

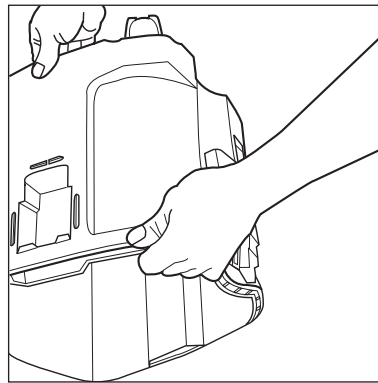

Only after picking up harmless dust without a filter bag.

1. Remove the upper section of cleaner from the dirt tank.
 2. Using one hand, take hold of the dirt tank underneath and tip out the dirt.
 3. Dispose of the dirt in accordance with legal regulations.
 4. Clean the rim of the tank before fitting the upper section of cleaner.
- Before reinserting the suction hose:
5. Clean the inlet fitting and hose collar.

7.2.6 Emptying the dirt tank (IVB 7-H)

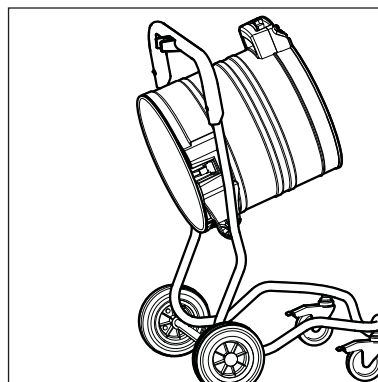
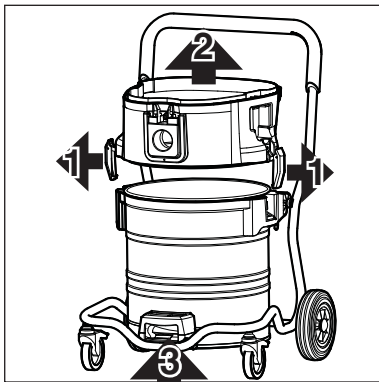

1. Remove the upper section of cleaner from the dirt tank.
2. Open the retaining clamps (1) and remove the intermediate ring (2) from the tank.
3. Pull the lever in the handle (3) upwards and tilt the tank.
4. Tip out the collected dirt.
5. Dispose of the dirt in accordance with legal regulations.

or:

3. Open the tank locks (4).
4. Use the handles (5) to lift the tank out of the frame.
5. Tip out the collected dirt.
6. Place the empty tank in the frame and close the locks (4).
7. Dispose of the dirt in accordance with legal regulations.



Only after picking up harmless dust without a filter bag.



To empty the dirt tank after picking up liquids: remove the intermediate ring as a proper seal is only ensured during suction. After emptying the tank: clean the rim of the tank and the seals in the intermediate ring and the upper section of cleaner before refitting them.

If the seal or groove is dirty or damaged, the suction performance will

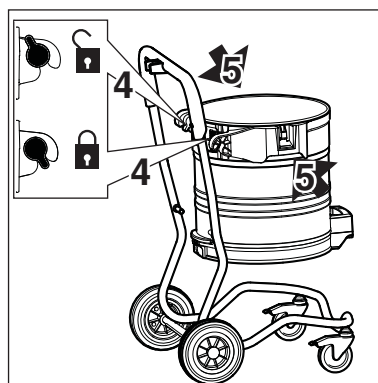

be reduced.

Before reinserting the suction hose: clean the inlet fitting and hose collar.

8 Troubleshooting

Fault	Cause	Remedy
‡ Motor does not start	<ul style="list-style-type: none"> > Fuse of the mains socket has blown. > Overload protection switch has tripped. > Self-acting carbon brush is worn. 	<ul style="list-style-type: none"> • Connect mains fuse. • Switch off the vacuum cleaner and allow it to cool for approx. 5 minutes. If the cleaner cannot be started again, contact the Nilfisk-Advance service department. • Have carbon brushes changed by Nilfisk-Advance Service.
‡ Motor does not run in automatic mode	<ul style="list-style-type: none"> > Power tool is defective or not connected properly. > The power rating of the electrical tool is too low. 	<ul style="list-style-type: none"> • Check that the power tool works or that the plug is inserted correctly. • Note that minimum power rating is P>40W
‡ The acoustic warning sounds. (Reduced suction power)	<ul style="list-style-type: none"> > Suction power selected with suction power control is too low. > Hose diameter is not right for switch position. > Clogged suction hose/nozzle. > The safety filter bag is full. > Filter element is clogged. > Defective cleaning mechanism 	<ul style="list-style-type: none"> • Set suction power in accordance with section 4.2.3. „Setting suction power“. • Set correct switch position for hose diameter. • Clean suction hose/nozzle • See section 7.2.2 „Replacing filter bag“. • See section 4.5 „Cleaning filter element“ and 7.2.3 „Replacing filter element“. • Contact Nilfisk-Advance Service
‡ No suction power during wet cleaning	<ul style="list-style-type: none"> > Tank is full. (Float is blocking the suction opening). 	<ul style="list-style-type: none"> • Switch off the cleaner. Empty the tank.
‡ The vacuum cleaner switches off during wet cleaning	<ul style="list-style-type: none"> > Tank is full. 	<ul style="list-style-type: none"> • Switch off the cleaner. Empty the tank.
‡ Voltage fluctuations	<ul style="list-style-type: none"> > Impedance of power supply is too high. 	<ul style="list-style-type: none"> • Connect the cleaner to another socket closer to the fuse box. Voltage fluctuations over 7% should not occur if the impedance at the transfer point is $\leq 0.15 \Omega$.

9 Further information

9.1 Recycling the vacuum cleaner

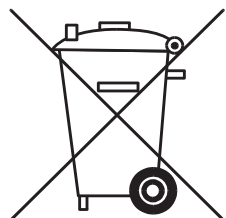

Make the old cleaner unusable immediately.

1. Unplug the cleaner and cut the power cord.

Do not discard of electrical appliances with household waste.

As specified in European Directive 2002/96/EC on old electrical

and electronic appliances, used electrical goods must be collected separately and recycled ecologically.

Contact your local authorities or your nearest dealer for further information.

9.2 Guarantee

Our general conditions of business are applicable with regard to the guarantee. Subject to change as a result of technical advances.

9.3 Tests and approvals

The vacuum cleaners have been tested as specified in IEC/EN 60335-2-69 including appendix AA. All the requirements were fulfilled for equipment in dust class H.

The vacuum cleaners must be inspected regularly in accordance with national accident prevention regulations (in Germany as specified in VBG 4 and DIN VDE 0701 Part 1 and Part 3, at regular intervals and after repairs or modifications).

A dust test must be performed at least once every year by the manufacturer or a trained person. This test covers, for example, whether there is damage to the filter, the vacuum cleaner is sealed to the air and the control equipment works properly.

9.4 Technical data



		IVB								
		3-H			5-H			7-H		
		EU	GB 230/240V	GB 110V	EU	GB 230/240V	GB 110V	EU	GB 230/240V	GB 110V
Voltage	V	230	230/240	110	230	230/240	110	230	230/240	110
Mains frequency	Hz	50/60								
Fuse	A	16	13	16	13	16	13	16	13	16
Power consumption	W	1200								
Connected load for appliance socket	W	2400	1800	560	2400	1800	560	2400	1800	560
Total connected load	W	3600	3000	1760	3600	3000	1760	3600	3000	1760
Air flow rate	l/min	3600								
Vacuum	mbar/kPa	230/23								
Measurement area sound pressure level at a distance of 1 m, EN 60704-1	dB(A)	62			60					
Sound level	dB(A)	59			57					
Power cord: Length	m	7.5								
Power cord: Type		H05RR- F3G1.5	H07BQ- F3G1.5		H05RR- F3G1.5	H07BQ- F3G1.5		H05RR- F3G1.5	H07BQ- F3G1.5	
Protection class		I								
Type of protection (splash water protected)		IP X4								
Radio interference level		EN 55014-1								
Tank volume	l	27			45			70		
Width	mm	380			476			580		
Depth	mm	390			506			605		
Height	mm	570			655			970		
Weight	kg	10			14			27		

Suction hose diameter mm	Minimum air flow volume l/min	Associated negative pressure between suction hose/tool Pa
27	690	16300
32	970	15700
38	1360	13900
50	2360	7800

9.5 Optional accessories

Description	Order No.		
	IVB 3-H	IVB 5-H	IVB 7-H
Safety filter bag (5 pcs.)	302001910	302001143	302001912
Waste bag (5 pcs.)	302001310	302001311	302001480
Filter element „H“	302000462	302001137	
Protective filter bag (10 pcs.)	30082		
Filter screen	15475	-	
Cloth insert filter	302001370	302001371	
Nilfisk-Alto-Foam-Stop (6 x 1 l)	8469		

9.6 EC declaration of conformity

 EC declaration of conformity	
NILFISK-ADVANCE A/S Sognevej 25 DK-2605 Brøndby	
Product:	Vacuum cleaner for wet and dry operation
Model:	IVB 3-H/5-H/7-H
Description:	110/230-240 V-, 50/60 Hz, 1200 W, Dust class H
The design of the appliance corresponds to the following pertinent regulations:	EC Machine Directive 98/37/EC EC Low Voltage Directive 73/23/EC EC EMC Directive 2004/108/EC
Applied harmonized standards:	EN 12100-1, EN 12100-2 EN 60335-1 EN 60335-2-69 EN 55014-1, EN 55014-2, EN 61000-3-2
Applied national standards and technical specifications:	DIN EN 60335-1 DIN EN 60335-2-69
 Jørgen Jensen	Brøndby, 04.07.2005



Nilfisk-Advance A/S
Sognevej 25
DK-2605 Brøndby
Denmark
Tel.: +45 43 23 81 00
Fax: +45 43 43 77 00
www.nilfisk-advance.com