

BRIGGS & STRATTON CORP.
MODEL SERIES 92900 AND 110900

This engine is equipped with a Manual Friction governor control, which may be used to change engine speed and stop the engine. A remote control is not required. A unique automatic choke permits starting when the control lever is placed in any position, except STOP. In most cases, the engine may be used as is, without adding a remote control.

If it is necessary to use a remote control, the following instructions are of importance:

BEFORE INSTALLING REMOTE CONTROL

This automatic choke engine is designed to accept a remote control which is calibrated as shown in Figure 1. The control should have the STOP position at one end of the range and the FAST position at the opposite end of the range. There must be a minimum wire travel of 1-1/16" between STOP and FAST positions. If a new remote control will be used, obtain a control which meets these specifications.

If the old remote control will be used, and if the remote control was designed for use with a Choke-A-Matic carburetor, use only the control range between STOP and FAST. Disregard that portion of the control travel which was previously required to choke the engine.

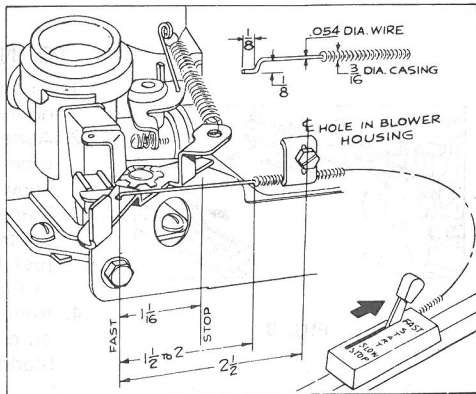

FIG. 1

BEFORE INSTALLING REMOTE CONTROL

1. Remove air cleaner assembly.
2. Move carburetor control lever to a position about midway between SLOW and FAST.
3. Use a screwdriver to pry up the control lever as shown in Figure 2. Bend the lever just enough to eliminate the friction of the detent.
4. Move Manual Friction governor control lever to the STOP position to be sure that it contacts the stop switch blade.
5. Place a few drops of oil at the pivot pin as shown

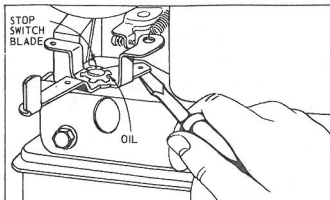

FIG. 2

TO INSTALL AND ADJUST REMOTE CONTROL

1. Mount remote control lever on equipment in its normal position.
2. Assemble the control wire and casing to the engine with the casing clamp and screw "A" as shown in Figure 3. Leave screw "A" loose.
3. Place remote control lever in FAST position. Slide control casing "B" in clamp until lever "C" is just touching the boss on the carburetor as shown in Figure 3. Tighten screw "A".
4. Move remote control lever to STOP position to be sure carburetor lever contacts the stop switch blade.

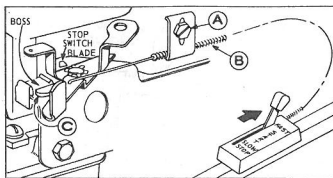

FIG. 3

BRIGGS & STRATTON CORP.
Milwaukee, Wisconsin 53201