

Color Monitor

The IBM logo is rendered in its classic eight-stripe font, with each letter composed of horizontal bars.

T541A

User's Guide

English

First Edition (Feb/2002)

Note: For important information, refer to the Monitor Safety and Warranty manual that comes with this monitor.

Contents

Safety(Read first)	2
Setting up the monitor	3
Product Description	3
Handling Instructions	3
Workplace Preparation	4
Adjusting the Monitor Position	4
Working Practices	4
Connecting your Monitor	6
Switching on your Monitor	6
Device driver Installation	7
Windows XP	7
Windows Millennium	7
Windows 2000	8
Windows 98	8
Windows 95	9
Auto Setup	10
Auto Setup for DOS	10
Auto Setup for Windows 3.1, Windows 95, Windows 98, Windows 2000, Windows NT, Windows Me or Windows XP	12
Adjusting Your LCD Monitor	14
User controls	14
On-screen display (OSD) controls	16
Further Information	19
Display modes	19
Power Management	20
Product Disposal	20
Troubleshooting	21
Further Help	23
Specifications	26
Service Information	27
Notices and trademarks	28

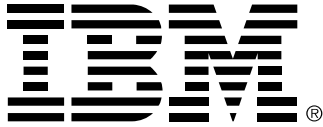

Safety: Read first

Before installing this product, read the Safety Information.

Avant d'installer ce produit, lisez les consignes de sécurité.

Vor der Installation dieses Produkts die Sicherheitshinweise lesen.

Πριν εγκαταστήσετε το προϊόν αυτό, διαβάστε τις πληροφορίες ασφάλειας (safety information).

לפני שתתקינו מוצר זה, קראו את הוראות הבטיחות.

A termék telepítése előtt olvassa el a Biztonsági előírásokat!

Prima di installare questo prodotto, leggere le Informazioni sulla Sicurezza

Antes de instalar este produto, leia as Informações de Segurança.

Läs säkerhetsinformationen innan du installerar den här produkten.

Prije instalacije ovog produkta obavezno pročitajte Sigurnosne Upute.

Les sikkerhetsinformasjonen (Safety Information) før du installerer dette produktet.

Przed zainstalowaniem tego produktu, należy zapoznać się z książką "Informacje dotyczące bezpieczeństwa" (Safety Information).

Пред да се инсталира овој продукт, прочитајте информацијата за безбедност.

Pred inštaláciou tohto zariadenia si peèitajte Bezpeènostné predpisy.

Pred namestitvijo tega proizvoda preberite Varnostne informacije.

Ennen kuin asennat tämän tuotteen, lue turvaohjeet kohdasta Safety Information.

Před instalací tohoto produktu si přečtěte příručku bezpečnostních instrukcí.

在安装本产品之前，请仔细阅读 **Safety Information** (安全信息)。

安裝本產品之前，請先閱讀「安全資訊」。

مج، يجب قراءة دات السلامة

Læs sikkerhedsforskrifterne, før du installerer dette produkt.

製品の設置の前に、安全情報をお読みください。

본 제품을 설치하기 전에 안전 정보를 읽으십시오.

Antes de instalar este producto lea la información de seguridad.

Antes de instalar este produto, leia as Informações de Segurança.

Перед установкой продукта прочтите инструкции по технике безопасности.

Lees voordat u dit product installeert eerst de veiligheidsvoorschriften.

Setting up the monitor

Product Description

The IBM T541A Color Monitor works with a computer with a suitable on-board sub-system or Video Card that supports XGA1024 x 768, SVGA 800 x 600, or VGA 604 x 408 resolutions at 60Hz.

In addition to your monitor, your option package includes the following:

- User's Guide and Installation Files CD
- Monitor Warranty and Safety manual
- T541A Color Monitor Quick Start Guide
- Power Cord
- T541A Color Monitor

Handling Instructions

Do not support the monitor within the screen area. The Liquid Crystal Display is glass and can be damaged by rough handling or excessive pressure.

1. Lift the monitor by placing your hands where indicated below.

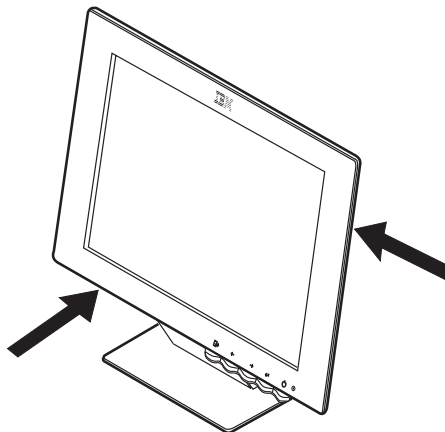

2. Before using your monitor for the first time, remove the clear protective film from the front of the screen.

Workplace Preparation

i This section gives advice on what you should consider before you set up your monitor.

Height

Position the monitor so that the top of the screen is slightly below your eye level when you sit at your workstation.

Orientation

Choose a position that gives the least reflection from lights and windows, usually at a right angle to any windows. Position the monitor directly in front of you so that you do not have to twist your body to use it. Tilt the monitor to a comfortable viewing angle.

Adjusting the Monitor Position

Viewing Angle

You can tilt the screen backward and forward as shown below.

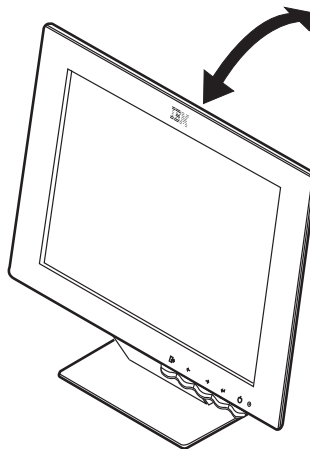

Working Practices

i This section gives advice on how you can work comfortably and reduce fatigue.

Rest

Take regular breaks. Vary your posture, stand up and stretch occasionally as prolonged use of computer workstations can be tiring.

Back

Sit back in your chair and use the backrest.

Hands

Adjust the seat height so that your forearms are approximately horizontal and your wrists are straight when using the keyboard. Your upper arms should be relaxed with your elbows near your body.

Use a light touch on the keyboard, keeping your hands and fingers relaxed. Allow a space in front of the keyboard to rest your wrists when not typing. Consider using a wristpad.

Eyesight

Working with monitors, in common with any prolonged close work, can be visually demanding. Look away from the screen periodically and have your eyesight checked regularly.

Screen settings

Set the screen brightness and contrast to a comfortable level. You may have to adjust this as the lighting changes during the day. Many application programs let you select color combinations which can help you to view in comfort. See the ***User controls*** section (page 10) for more information.

Connecting your Monitor

Be sure to read the **Monitor Safety and Warranty** manual that comes with your monitor before carrying out this procedure.

1. Turn off your computer and all attached devices.
2. Connect the signal cable to the video port on the back of your computer. This port might be directly attached to your computer (figure A), or it might be part of a video adapter card (figure B). The video port on your computer or video adapter card may be colored blue to match the blue connector on your monitor's video cable.

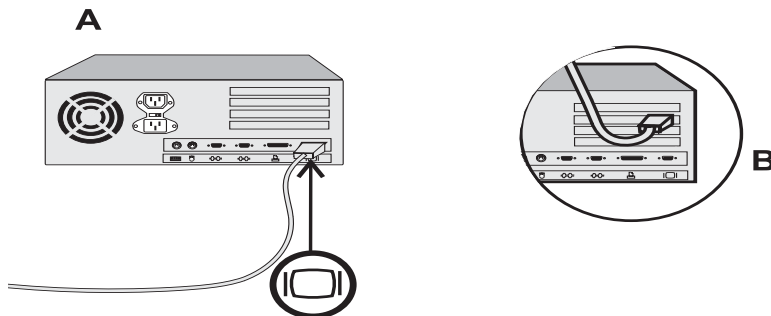

i The ac adapter and signal cable are connected to your monitor. If you wish to change these or to fit a different stand, see the **Further help** section (page 19).

3. Connect the power cord to the power adapter and then plug the power cord into a properly grounded outlet.

Switching on your Monitor

1. Switch on the power source and your computer.
2. Switch on your monitor by pushing and releasing the power switch marked . To switch off your monitor, push and release the power switch again.
3. Turn on the monitor and then the computer.

Device driver installation

Use the *User's Guide* and *Installation Files CD* that comes with your monitor to install the appropriate device driver for your operating system.

Installing the Windows XP device driver

To manually install or update the device driver for the Microsoft[®] Windows[®] XP operating system, perform the following steps:

1. Insert the *User's Guide* and *Installation Files CD* into the computer CD-ROM drive.
2. Click **Start** → **Control Panel** → **Appearance & Themes** and then click the **Display** icon.
3. In the Display Properties window, click the **Settings** tab, and then click **Advanced**.
4. Click the **Monitor** tab, and then click **Properties** → **Driver** tab → **Update Driver**.
5. When the Hardware Update Wizard window opens, select "Install the software automatically," click **Next>** and then **Finish** to complete the installation.
6. Close the Display Properties window.
7. Remove the *User's Guide* and *Installation Files CD* from the computer CD-ROM drive.

Installing the Windows Me device driver

To manually install or update the device driver for the Microsoft Windows Millennium Edition operating system, perform the following steps:

1. Click **Start** → **Settings** → **Control Panel** and then double-click **Display**.
2. In the Display Properties window, click the **Settings** tab, and then click **Advanced**.
3. Click the **Monitor** tab, and then click **Change** → **Specify the location of the driver** → **Next**.
4. When the Update Device Driver Wizard window opens, select "Display a list of all the drivers in a specific location, so you can select the driver you want," and click **Next>**.
5. Insert the the *User's Guide* and *Installation Files CD* into the computer CD-ROM drive, then click **Have Disk**.
6. Type d:\ (change the drive letter to match your CD-ROM drive if it is not drive D) in the **Copy manufacturer's files from:** box, then click **OK**.
7. Click **Next>**, **Next>**, and then **Finish** to complete the installation.
8. Close the Display Properties window.
9. Remove the *User's Guide* and *Installation Files CD* from the computer CD-ROM drive.

Installing the Windows 2000 device driver

To manually install or update the device driver for the Microsoft Windows 2000 Professional operating system, perform the following steps:

1. Click **Start** → **Settings** → **Control Panel** and then double-click **Display**.
2. In the Display Properties window, click the **Settings** tab, and then click **Advanced**.
3. Click the **Monitor** tab, and then click **Properties** → **Driver** → **Update Driver**.
4. When the Update Device Driver Wizard window opens, select "Search for a suitable driver for my device," and click **Next>**.
5. Insert the *User's Guide* and *Installation Files CD* into the computer CD-ROM drive, type d:\ (change the drive letter to match your CD-ROM drive if it is not drive D) in the **Copy manufacturer's files from:** box, click **Next>** and then **Finish** to complete the installation.
6. Close the Display Properties window.
7. Remove the *User's Guide* and *Installation Files CD* from the computer CD-ROM drive.

Installing the Windows 98 device driver

Windows 98 automatically detects the new monitor and displays the Add New Hardware Wizard window if the device driver is not already installed.

1. Insert the Device Driver and *User's Guide* CD into the computer CD-ROM drive, and click **Next>** twice when the Add New Hardware Wizard window opens.
2. Click the **CD-ROM drive** box to install the device drivers from the CD and then click **Next>**.
3. Confirm that the device driver was found on the CD, and click **Next>** twice to install the device driver.
4. Click **Finish** to exit the Add New Hardware Wizard window.

To manually install or update the device driver for the Microsoft Windows 98 operating system, perform the following steps:

1. Click **Start** → **Settings** → **Control Panel** and then double-click **Display**.
2. In the Display Properties window, click the **Settings** tab, and then click **Advanced**.
3. Click the **Monitor** tab, and then click **Change**.
4. When the Update Device Driver Wizard window opens, follow the steps in the previous paragraph.
5. Remove the *User's Guide* and *Installation Files CD* from the computer CD-ROM drive.

Installing the Windows 95 device driver

Right-click the My Computer icon on the computer desktop and then select **Properties** -> **System** to view the version number listed in the System window. Perform the steps below for the appropriate version.

If you have Windows 95 Version 4.00.950A, use the following steps to manually install or update the device driver:

1. Click **Start** → **Settings** → **Control Panel** and then double-click **Display**.
2. In the Display Properties window, click the **Settings** tab and then click **Change Display Type**.
3. In the **Change Display Type** window, click **Change** and then click **Have Disk**.
4. Insert the *User's Guide* and *Installation Files CD* into the computer CD-ROM drive, type d:\ (change the drive letter to match your CD-ROM drive if it is not drive D) in the **Copy manufacturer's files from:** box, and click **OK**.
5. In the Select Device window, click the appropriate monitor model and then click **OK**.
6. In the Change Display Type window, click **Close**.
7. In the Display Properties window, click **OK**.
8. Remove the *User's Guide* and *Installation Files CD* from the computer CD-ROM drive.

If you have Windows 95 Version 4.00.950B, use the following steps to manually install or update the device driver:

1. Click **Start** → **Settings** → **Control Panel** and then double-click **Display**.
2. In the Display Properties window, click the **Settings** tab and then click **Advanced Properties**.
3. In the Advanced Display Properties window, click the **Monitor** tab and then click **Change**.
4. In the Select Device window, click **Have Disk**.
5. Insert the *User's Guide* and *Installation Files CD* into the computer CD-ROM drive, type d:\ (change the drive letter to match your CD-ROM drive if it is not drive D) in the **Copy manufacturer's files from:** box, and click **OK**.
6. In the Select Device window, click the appropriate monitor model and then click **OK**.
7. In the Advanced Display Properties window, click **Close**.
8. In the Display Properties window, click **OK**.
9. Remove the *User's Guide* and *Installation Files CD* from the computer CD-ROM drive.

Auto Setup

Auto Setup

i The Setup Utility included on the setup diskette is for displaying do patterns. They do not replace or modify the display driver.

The Auto Setup instructions require the monitor to be warmed up for 15 minutes. This is not required for normal operation.

By pressing the ← and → keys simultaneously allows direct access to the auto **set-up** controls.

When you first use your monitor you must perform Auto Setup. This procedure sets up your monitor to process the video signals from your computer without image discoloration or smearing. After you perform Auto Setup, the settings are stored and used each time you turn on the monitor.

In order to optimise the displayed image a set-up utility is provided on the CD. Operation of the utility is dependent on the operating system on your PC. For correct operation locate the operating system on your PC from the table below and follow the appropriate instructions. You may choose to run AUTO SETUP for each operating system that you use. This means that if you sometimes use your monitor while running any version of Windows and sometimes also use it from within DOS (not a DOS window), you must run AUTO SETUP for both Windows and DOS. You may run versions of AUTO SETUP in any order.

Operating System	Corresponding Auto Setup procedure
DOS	Auto Setup for DOS
Windows 3.1, Windows 95, Windows 98, Windows 2000, Windows NT, Windows Me or Windows XP	Auto Setup for Windows 3.1, Windows 95, Windows 98, Windows 2000, Windows NT, Windows Me or Windows XP

Before you begin AUTO SETUP for your PC:

1. Make sure the PC's video mode is set in the range of the supported screen resolution shown in the table.

You should perform AUTO SETUP for each screen mode you use.

The AUTO SETUP process only applies to the current screen mode. When a new mode is selected, repeat this section to reset the monitor









Auto Setup for DOS

i If the monitor is in standby mode (STANDBY ON), it may automatically turn off while you are waiting for it to warm up. If this happens, switch off the monitor and switch it on again after a few seconds.

i If you are using PC-DOS/ V, change to U.S. mode by typing 'CHEV US' and pressing ENTER at the command prompt.

You must use DOS when you run DOS Auto Setup.

i The size and diversity of the dot pattern varies with the screen resolution.

1. Turn on the monitor first; then the PC.
If the message CHECK SIGNAL CABLE is displayed, or if nothing is displayed check:
 - that the video interface cable is connected properly.
 - the correct video adapter card is installed.
 - the correct supported display mode is selected for your PC.
2. Wait approximately 15 minutes, until the monitor warms up.
3. Insert the *User's Guide* and *Installation Files CD* into the computer CD-ROM drive.
4. Display the command prompt screen of the DOS full-screen display.
5. Type d:\ (change the drive letter to match your CD-ROM drive if it is not drive D).
6. Type 'TESTPAT' and press ENTER.
7. Select from the screen the number for the color or text mode you want to setup.
8. Select from the screen the number for the video mode you want to setup.
You may repeat this process for as many of the color and video modes as you need.
9. When the dot pattern appears, press the OSD Enter button  at the bottom of the monitor to display the initial OSD menu.
10. Use an Arrow button ( or ) to select the IMAGE LOCK icon  then press the OSD Enter  button to access the function.
11. Using an Arrow button ( or ), select AUTOMATIC and press the OSD Enter button . This activates the AUTO SETUP procedure, which will optimize the display settings with the provided dot-patterns.
The screen will blink off several times and you may notice small changes to the test pattern.
12. When finished, the OSD main menu returns. Press the Exit button  to exit from the OSD.
13. Press the ESCAPE key to exit the test pattern program.
14. Type 'Exit' at the command prompt to return to Windows.

If you use other operating systems, perform the appropriate AUTO SETUP for those systems, also: see

Auto Setup for Windows 3.1, Windows 95, Windows 98, Windows NT or Windows 2000, Windows Me or Windows XP.

Auto Setup for Windows 3.1, Windows 95, Windows 98, Windows NT or Windows 2000, Windows Me or Windows XP

i If the monitor is in standby mode (STANDBY ON), it may automatically turn off while you are waiting for it to warm up.

1. Turn on the monitor first; then the PC.









If the message CHECK SIGNAL CABLE is displayed, or if nothing is displayed check:

- that the video interface cable is connected properly.
- the correct video adapter card is installed.
- the correct supported display mode is selected for your PC.

2. Wait approximately 15 minutes, until the monitor warms up.
3. Drag the icon bar and tool bar, if they are displayed, to the bottom of the screen.
4. Insert the *User's Guide and Installation Files CD* into the computer CD-ROM drive.
5. Check the operating system installed on your PC and follow the instructions from the table below.

i The size and diversity of the dot pattern varies with the screen resolution.

Operating System	Step1	Step2	Step3	Step4
Windows 3.1	Open PROGRAM MANGER	Select FILE	Select RUN	Type 'd:\TESTPAT' (change the drive letter to match your CD-ROM drive if it is not drive D) and press ENTER
Windows NT 3.5				
Windows 95, Windows 98, Windows 2000, Windows NT, Windows Me or Windows XP	Select START	Select RUN		

6. When the test pattern appears, press the OSD Enter button  at the bottom of the monitor to display the initial OSD menu.
7. Use an Arrow button ( or ) to select the IMAGE LOCK icon  and press the OSD Enter button  to access the function.
8. Using an Arrow button ( or ), select AUTOMATIC and press the OSD Enter button . This activates the AUTO SETUP procedure, which will optimize the display settings with the provided test pattern.

The screen will dim, blink on and off several times, and you may notice small changes to the test pattern.

To abort the AUTO SETUP function, press the Esc key.

i Position the mouse pointer at the bottom center of the screen. This allows AUTO SETUP to run properly

9. When finished, the OSD main menu returns. Press the Exit button  once to exit from the OSD.
10. Press the Esc key to return to Windows.

You have completed the monitor setup for Windows. If you use other operating systems, perform the appropriate AUTO SETUP for those systems, also: see **Auto Setup for DOS**.

Adjusting Your LCD Monitor

User controls



User control features

Icon	Control	Description
	Exit	Displays the OSD main menu Exits from menus and sub-menus Exits the OSD
	Left Arrow	Displays the OSD main menu Moves the cursor to highlight icons and other options
	Right Arrow	Displays the OSD main menu Moves the cursor to highlight icons and other options
	OSD Enter	Displays the OSD main menu Enters menus and sub-menus and selects the highlighted option
	Power Switch	Switches the monitor on and off

Operation

- Press any of the OSD control buttons to display the main OSD menu.
- Use the Arrow buttons to move among the icons. Select an icon and press OSD Enter to access that function. If there is a sub-menu, you can move between options using the Arrow buttons, then press OSD Enter to select that function. Use the Arrow buttons to make adjustments.

i The image is already optimized for many display modes; however, the user controls can be used to adjust the image to your liking.

i The settings are saved after adjustment and when exiting the OSD and will be effective thereafter.

- Press the Exit button to move backwards through the sub-menus and exit from the OSD.

Note: After making adjustments, the Power indicator LED will briefly turn amber to indicate that the new value has been saved.

OSD Lock / Unlock

This feature allows you to secure the current control settings, while allowing the user to adjust Brightness and Contrast, so that they cannot be inadvertently changed. You can unlock the OSD controls at any time by using the same procedure.

Push and hold the OSD Enter button for 10 seconds to Lock or to Unlock. When locked, a “LOCKED” message will be displayed.

On-screen display (OSD) controls







The settings adjustable with the user controls are viewed through the On-Screen Display (OSD). Press any of the OSD buttons to activate the OSD.







***i** The LCD monitor needs time to become thermally stable the first time you turn it on each day. Thus, to achieve more accurate adjustments for parameters, allow the LCD monitor to warm up (be On) for at least 15 minutes before making any screen adjustments.*







Initial appearance of OSD



OSD functions

OSD Icon	Description	Sub-menu(s)	Controls and Adjustments	
 BRIGHTNESS	Adjusts brightness		 ←	 →
 CONTRAST	Adjusts contrast		 ←	 →
 IMAGE LOCK	The image lock function is used to adjust the level of noise in the video signal which causes horizontal lines or areas on the screen where the image appears to be unstable and jitters or shimmers. This can be done automatically or manually.	Automatic	Automatic adjustment	

OSD Icon	Description	Sub-menu(s)	Controls and Adjustments	
 <p>IMAGE LOCK (continued)</p>		Manual - <ul style="list-style-type: none"> • Fine • Coarse 	Use the Arrow buttons to adjust away the interference. If satisfactory results are not obtained using the Fine adjustment, use the Coarse adjustment and then use Fine again. This function may change the width of the display image. Use the H-Position function on the Image Position menu to center the display image on the screen.	
 <p>IMAGE POSITION</p>	Moves the screen left and right or up and down.	H-Position		
		V-Position		
 <p>COLOR</p>	Select the Color Mode you find most comfortable and then fine tune the colors using the User Color Mode menu, if necessary.	Color Mode	Mode 1 (Cool White) Mode 2 (Normal White) Mode 3 (Warm White)	
		User Mode - <ul style="list-style-type: none"> • Red 	Increases or decreases redness	
		<ul style="list-style-type: none"> • Green 	Increases or decreases greenness	
		<ul style="list-style-type: none"> • Blue 	Increases or decreases blueness	

OSD Icon	Description	Sub-menu(s)	Controls and Adjustments
 RESET	Resets the Brightness, Contrast and Color settings.	Color Reset	NO - Does not make the adjustment YES - Resets the color
	Resets the Image position settings	Geometry Reset	NO - Does not make the adjustment YES - Resets the geometry
 INFORMATION	Shows information about the addressability and the horizontal and vertical frequencies of the images received from the computer or video board.		
 LANGUAGE	The language chosen affects only the language of the OSD. It has no effect on any software running on the computer.		Select one of the five languages to use for the OSD.
 OSD MENU POSITION	Changes the position of the OSD on the screen.	H-Position	
		V-Position	

Further Information

Display modes

The display mode the monitor uses is controlled by the computer. Therefore, you should refer to your computer documentation for details on how to change display modes.

The image size, position and shape may change when the display mode changes. This is normal and the image can be readjusted using AUTO SETUP and the monitor controls.

Unlike CRT monitors, which require a high refresh rate to minimize flicker, TFT technology is inherently flicker-free. If possible, configure your computer for 1024 × 768 addressability at 60Hz vertical refresh rate.

For the display modes listed below, the screen image has been optimized during manufacture.

Factory Set Display Modes

Addressability	Refresh Rate	Horizontal Frequency
640 × 350	70 Hz	31.5 kHz
640 × 480	60 Hz	31.5 kHz
640 × 480	72 Hz	37.9 kHz
640 × 480	75 Hz	37.5 kHz
720 × 400	70 Hz	31.5 kHz
800 × 600	75 Hz	46.9 kHz
800 × 600	72 Hz	48.1 kHz
800 × 600	60 Hz	37.9 kHz
800 × 600	56 Hz	35.2 kHz
832 × 624	75 Hz	49.7 kHz
1024 × 768†	60 Hz	48.4 kHz
1024 × 768	70 Hz	56.5 kHz
1024 × 768	75 Hz	60.0 kHz

† Recommended

Note: VESA timings are as detailed in the VESA “Display Monitor Timing Specification”. Version 1.0, Revision 0.8, dated 09/17/98.

Power Management

***i** If your computer has previously been used with a CRT monitor and is currently configured to a display mode outside the range that the Flat Panel monitor can display, you may need to re-attach the CRT monitor temporarily until you have re-configured the computer, preferably to 1024 x 768 at 60Hz.*

To benefit from power management, the monitor must be used in conjunction with a computer that implements the Video Electronics Standards Association (VESA) Display Power Management Signalling (DPMS) Standard.

The power management feature is invoked when the computer recognizes that you have not used your mouse or keyboard for a user-definable period. There are several states as described in the table below.

As an ENERGY STAR[®] Partner, IBM has determined that this product meets the ENERGY STAR[®] guidelines for energy efficiency.

For optimal performance, you switch off your monitor at the end of each working day, or whenever you expect to leave it unused for long periods during the day.

State	Power Indicator	Screen	Restoring Operation	Compliance
On	Steady green	Normal		
Active Off	Steady amber	Blank	Press a key or move the mouse.	ENERGY STAR [®] and NUTEK
Off	Steady amber	Blank	Press a key or move the mouse. ‡	ENERGY STAR [®] and NUTEK

‡ There may be a slight delay before the picture reappears.

Product Disposal

The fluorescent lamp in the liquid crystal display contains a small amount of mercury. Dispose of it as required by local ordinances and regulations.

Troubleshooting

If you have a problem setting up or using your monitor, you may be able to solve it yourself. Before calling your retailer or IBM, try the suggested actions that are appropriate to your problem.

Problem	Possible Cause	Suggested Action	Reference
Screen is blank and power indicator is off	No power to monitor	<ul style="list-style-type: none">◆ Ensure that the electrical outlet and the monitor are both switched on.◆ Check that the power cord is firmly plugged into the electrical outlet and the power supply unit.◆ If the power cord plug has a removable fuse, replace it.◆ Try another power cord.◆ Try another electrical outlet.	Connecting your Monitor section (page 6)
Screen is blank and power indicator is steady green	Brightness and Contrast may be too low	<ul style="list-style-type: none">◆ Adjust brightness and contrast.	User controls section (page 10)
Screen is blank and power indicator is steady amber	The monitor is in the Power Management Standby state	<ul style="list-style-type: none">◆ Press any key on the keyboard or move the mouse to restore operation.◆ Check the Power Management software on your computer	Power management section (page 16)

Problem	Possible Cause	Suggested Action	Reference
Screen is blank and power indicator is flashing green every 0.5 second	The monitor is not receiving a video signal	<ul style="list-style-type: none"> ◆ Check that the signal cable is firmly connected to the computer. ◆ Check that no pins are bent in the signal cable connector. 	Connecting your Monitor section (page 6)
	Display mode of the computer is outside the range of the monitor	<ul style="list-style-type: none"> ◆ Reconfigure the computer to use a supported display mode. 	Further information section (page 15)
Screen is blank and power indicator is amber every 0.5 or 1 second	The monitor is in the Power Management Suspend or Off state	<ul style="list-style-type: none"> ◆ Press any key on the keyboard or move the mouse to restore operation. ◆ Check the Power Management software on your computer. 	Power management section (page 16)
Image appears to be smeared	There is noise in the video signal	<ul style="list-style-type: none"> ◆ Select IMAGE LOCK menu in the OSD. Then select MANUAL to adjust FINE/COARSE settings. 	User controls section (page 10)
Image appears to be discolored	The Color setting may be incorrect	<ul style="list-style-type: none"> ◆ Adjust the Color settings. 	User controls section (page 10)
A few dots are missing, discolored, or inappropriately lighted.		<ul style="list-style-type: none"> ◆ The LCD contains over 2,300,000 thin-film transistors (TFTs). A small number of missing, discolored, or lighted dots may be present on the screen, which is an intrinsic characteristic of the TFT LCD technology and is not an LCD defect. 	

Further Help

Product warranty and support information

The following information describes the technical support that is available for your product, during the warranty period or throughout the life of the product. Refer to your IBM Statement of Limited Warranty for a full explanation of IBM warranty terms.

Warranty information on the World Wide Web

The IBM Machine Warranties Web site at http://www.ibm.com/servers/support/machine_warranties/ contains a worldwide overview of the IBM Limited Warranty for IBM Machines, a glossary of terms used in the Statement of Limited Warranty, Frequently Asked Questions (FAQ), and links to Product Support Web pages. The IBM Statement of Limited Warranty is available from this Web site in 29 languages in Portable Document Format (PDF).

Online technical support

Online technical support is available during the life of your product. Online assistance can be obtained through the Personal Computing Support Web site and the IBM Automated Fax System.

Online technical support

IBM Personal Computing Support Web site	http://www.ibm.com/pc/support
IBM Automated Fax System	1-800-426-3395 (U.S. and Canada)

During the warranty period, assistance for replacement or exchange of defective components is available. In addition, if your IBM option is installed in an IBM computer, you might be entitled to service at your location. Your technical support representative can help you determine the best alternative.

Telephone technical support

Installation and configuration support through the IBM HelpCenter« will be withdrawn or made available for a fee, at IBM's discretion, 90 days after the option has been withdrawn from marketing. Additional support offerings, including step-by-step installation assistance, are available for a nominal fee.

To assist the technical support representative, have available as much of the following information as possible:

- Option name
- Option number
- Proof of purchase
- Computer manufacturer, model, serial number (if IBM), and manual
- Exact wording of the error message (if any)

- Description of the problem
- Hardware and software configuration information for your system

If possible, be at your computer. Your technical support representative might want to walk you through the problem during the call.

For the support telephone number and support hours by country, refer to the following table. If the number for your country or region is not listed, contact your IBM reseller or IBM marketing representative. Response time may vary depending on the number and nature of the calls received.

Support 24 hours a day, 7 days a week	
Canada (Toronto only)	416-383-3344
Canada (all others)	1-800-565-3344
U.S.A. and Puerto Rico	1-800-772-2227
All other countries and regions	Go to http://www.ibm.com/pc/support ,and click Support Phone List .

***i** More help, late-breaking news and details of the latest accessories for these products may be found on the worldwide web at:*

<http://www.ibm.com/pc/us/accessories>

Information about the Video Electronics Standards Association can be found on the worldwide web at:

<http://www.vesa.org>

Changing cables

This product is shipped with the signal cable and the power cord attached to the monitor. If you want to use other cables, follow the instructions below:

1. Disconnect the power cord from the wall outlet.
2. Carefully insert the head of a flathead (–) screwdriver into the slot visible along either side of the cable cover (a) and pry it off.

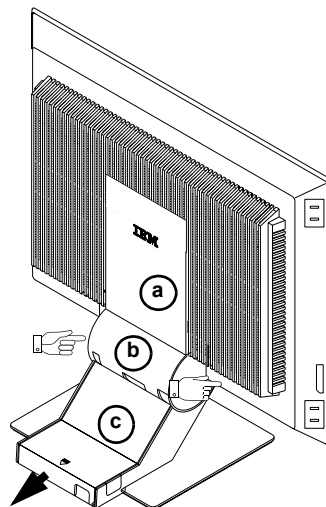

3. Squeeze the sides of the hinge cover (b) and pull it off.
4. Gently lift the stand cover (c) along the top and then slide it backwards and off the stand.
5. Remove the signal cable from the monitor and connect the new cable.
6. Slide the stand cover back on the stand.
7. Put the hinge cover back on, making sure that the straight side is at the top.
8. Insert the three tabs at the top of the cable cover into the slots in the back of the monitor and push the cover into place.

To obtain the correct cables and/or to get further instructions on installing them, call the IBM HELPCENTER at the above numbers or contact your dealer, retailer, or other IBM authorized Servicer.

Specifications

This color monitor (Type-model 9512-Ax0) uses a 15-inch TFT LCD

Dimensions	Width: Depth: Height:	365.2 mm (14.38 in.) 202.1 mm (7.96 in.) 344.8 mm (13.57 in.)
Weight	Unpackaged: Packaged:	4.1 Kg (9.03 lb) 5.3 Kg (11.68 lb)
Tilt	Forward Tilt: Backward tilt:	- 4° + 41°
Image	Viewable Image Size: Maximum Height: Maximum Width: Pixel Pitch:	381 mm (15 in.) 228.1 mm (8.98 in.) 304.1 mm (11.97 in.) 0.297 mm (H) × 0.297 mm (V) (0.012 in.(H) x 0.012 in.(V))
Power Input	Supply Voltage: Max Supply Current:	100 - 240 V ac 60/50 ± 3 Hz 1.0 A at 120 V ac
Power Consumption	Normal Operation: Active Off: Off:	< 30 W < 2 W < 2 W at 220 V ac & < 1 W at 100 V ac
Video Input	Input Signal: Horizontal Addressability: Vertical Addressability: Clock Frequency:	Analog Direct Drive 75 ohm 0.7 V 1024 pixels (maximum) 768 lines (maximum) 78 MHz
Communications	VESA DDC:	EDDC
Supported Display Modes	VESA Standard 12 modes Macintosh 1 mode	See Further Information
Environment	Temperature: Operating: Storage: Shipping: Humidity: Operating: Storage: Shipping:	10 to 35° C (50 to 95° F) - 20 to 60° C (-4 to 140° F) - 20 to 60° C (-4 to 140° F) 10 to 80% 5 to 95% 5 to 95%

Service Information

The following parts are for use by IBM service, or IBM authorized dealers, to support the customer warranty. Parts are for service use only.

Flat Panel Monitor, Type 9512

31P7164	9512-AB0	Monitor - Stealth Black
31P7165	9512-AW0	Monitor - Pearl White
31P7166	9512-DB0	Monitor - Stealth Black
31P7167	9512-DW0	Monitor - Pearl White
31P7168	9512-AB0/9512-DB0	Tilt/Swivel Base - Stealth Black
31P7169	9512-AW0/9512-DW0	Tilt/Swivel Base - Pearl White
31P7170	9512-AB0	Power Supply - Stealth Black
31P7171	9512-AW0	Power Supply - Pearl White

Notices and trademarks

This section contains information on notices and trademarks.

Notices

IBM may not offer the products, services, or features discussed in this document in all countries. Consult your local IBM representative for information on the products and services currently available in your area. Any reference to an IBM product, program, or service is not intended to state or imply that only that IBM product, program, or service may be used. Any functionally equivalent product, program, or service that does not infringe any IBM intellectual property right may be used instead. However, it is the user's responsibility to evaluate and verify the operation of any non-IBM product, program, or service.

IBM may have patents or pending patent applications covering subject matter described in this document. The furnishing of this document does not give you any license to these patents. You can send license inquiries, in writing, to:

*IBM Director of Licensing
IBM Corporation
North Castle Drive
Armonk, NY 10504-1785
U.S.A.*

The following paragraph does not apply to the United Kingdom or any country where such provisions are inconsistent with local law: INTERNATIONAL BUSINESS MACHINES CORPORATION PROVIDES THIS PUBLICATION "AS IS" WITHOUT WARRANTY OF ANY KIND, EITHER EXPRESS OR IMPLIED, INCLUDING, BUT NOT LIMITED TO, THE IMPLIED WARRANTIES OF NON-INFRINGEMENT, MERCHANTABILITY OR FITNESS FOR A PARTICULAR PURPOSE. Some states do not allow disclaimer of express or implied warranties in certain transactions, therefore, this statement may not apply to you.

This information could include technical inaccuracies or typographical errors. Changes are periodically made to the information herein; these changes will be incorporated in new editions of the publication. IBM may make improvements and/or changes in the product(s) and/or the program(s) described in this publication at any time without notice.

IBM may use or distribute any of the information you supply in any way it believes appropriate without incurring any obligation to you.

Any references in this publication to non-IBM Web sites are provided for convenience only and do not in any manner serve as an endorsement of those Web sites. The materials at those Web sites are not part of the materials for this IBM product, and use of those Web sites is at your own risk.

Compliances

Federal Communications Commission (FCC) Declaration of Conformity

IBM T541A or T541D Color Monitor 9512-Ax0 and 9512-Dx0

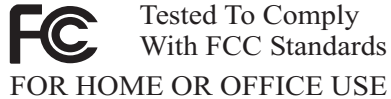

This equipment has been tested and found to comply with the limits for a Class B digital device, pursuant to Part 15 of the FCC Rules. These limits are designed to provide reasonable protection against harmful interference in a residential installation. This equipment generates, uses, and can radiate radio frequency energy and, if not installed and used in accordance with the instructions, may cause harmful interference to radio communications. However, there is no guarantee that interference will not occur in a particular installation. If this equipment does cause harmful interference to radio or television reception, which can be determined by turning the equipment off and on, the user is encouraged to try to correct the interference by one or more of the following measures:

- Reorient or relocate the receiving antenna.
- Increase the separation between the equipment and receiver.
- Connect the equipment into an outlet on a circuit different from that to which the receiver is connected.
- Consult an IBM authorized dealer or service representative for help.

Properly shielded and grounded cables and connectors must be used in order to meet FCC emission limits. Proper cables and connectors are available from IBM authorized dealers. IBM is not responsible for any radio or television interference caused by using other than recommended cables and connectors or by unauthorized changes or modifications to this equipment. Unauthorized changes or modifications could void the user's authority to operate the equipment.

Declaration of Conformity

Trade name: IBM Corporation

Model Nos.: 9512-Ax0 & 9512-Dx0

Responsible Party: Samsung Electronics Co.,Ltd.

Address: QA Lab of Samsung America

Telephone No.: 408-554-5124

This Device complies with Part 15 of the FCC Rules.

Operation is subject to the following two conditions: (1) This device may not cause harmful interference, and (2) this device must accept any interference received, including interference that may cause undesired operation.

Power Cords

For your safety, IBM provides a power cord with a grounded attachment plug to use with this IBM product. To avoid electrical shock, always use the power cord and plug with a properly grounded power outlet.

IBM power cords used in the United States and Canada are listed by the Underwriter's Laboratories (UL) and certified by the Canadian Standards Association (CSA).

For units intended to be operated at 115 volts: Use a UL-listed and CSA-certified cord set consisting of a minimum 18 AWG, Type SVT or SJT, three-conductor cord, a maximum of 15 feet in length and a parallel blade, grounding-type attachment plug rated 15 amperes, 125 volts.

For units intended to be operated at 230 volts (U.S. use): Use a UL-listed and CSA-certified cord set consisting of a minimum 18 AWG, type SVT or SJT, three-conductor cord, a maximum of 15 feet in length and a tandem blade, grounding-type attachment plug rated 15 amperes, 250 volts.

For units intended to be operated at 230 volts (outside the U.S.): Use a cord set with a grounding-type attachment plug. The cord set should have the appropriate safety approvals for the country in which the equipment will be installed.

IBM power cords for a specific country or region are usually available only in that country or region.

IBM power cord part number	Used in these countries or regions
13F9959	Antigua, Aruba, Bahamas, Barbados, Belize, Bermuda, Bolivia, Brazil, Caicos Island, Canada, Cayman Islands, Costa Rica, Columbia, Dominican Republic, Guam, Ecuador, El Salvador, Guatemala, Haiti, Honduras, Jamaica, Japan, Mexico, Netherlands Antilliles, Nicaragua, Panama, Peru, Phillipines, Saudi Arabia, Thailand, Taiwan, United States, Venezuela
1838576	Antigua, Aruba, Bahamas, Barbados, Belize, Bermuda, Bolivia, Brazil, Caicos Island, Canada, Cayman Islands, Costa Rica, Columbia, Dominican Republic, Guam, Ecuador, El Salvador, Guatemala, Haiti, Honduras, Jamaica, Japan, Mexico, Netherlands Antilliles, Nicaragua, Panama, Peru, Phillipines, Taiwan, United States, Venezuela
13F9978	Afghanistan, Albania, Algeria, Andorra, Angola, Armenia, Austria, Azerbaidjan, Belarus, Benin, Belgium, Bosnia, Burkina Faso, Burundi, Cameroon, Cambodia, Cape Verde, Central African Republic, Chad, Congo (Republic of), Comoros, Congo (Democratic Republic of), Cote D'Ivoire (Ivory Coast), Croatia, Czech Rep, Dahomey, Djibouti, Equatorial Guinea, Eqypt, Eritrea, Estonia, Ethiopia, Finland, France, French Guyana, French Polynesia, Gabon, Georgia, Germany, Greece, Guadeloupe, Guinea, Guinea Bissau, Hungary, Iceland, Indonesia, Iran, Kazakhstan, Korea (South), Kyrgyzstan, Laos, Latvia, Lebanaon, Lithuania, Luxemborg, Macedonia, Madagascar, Mali, Martinique, Mauritania, Maurit, Mayotte, Moldavia, Monaco, Mongolia, Morocco, Mozambique, Netherlands, New Caledonia, Niger, Nigeria, Norway, Poland, Portugal, Reunion, Romania, Russia, Rwanda, Sao Tome, Saudi Arabia, Senegal, Serbia, Slovakia, Solvenia, Somalia, Spain, Suriname, Sweden, Syria, Tajikistan, Togo, Tunisia, Turkey, Turkmenistan, Ukraine, Upper Volta, USSR (C.I.S.), Uzbekistan, Vanuatu, Vietnam, Wallia and Futuna, Yugoslavia, Zaire
13F9996	Denmark
14F0050	Lichtenstein, Switzerland
14F0086	Israel
14F0068	Chile, Italy, Libya
14F0014	Bangladesh, India, Lesotho, Maldives, Nambia, Nepal, Pakistan, Samoa, South Africa, Sri Lanka, Swaziland, Uganda
14F0032	Bahrain, Brunei, Botswana, Channel Islands, Cyprus, Dominica, Gambia, Ghana, Grenada, Guyana, Hong Kong, Iraq, Ireland, Jordan, Kenya, Kuwait, Liberia, Malawi, Malaysia, Malta, Myanmar (Burma), Nigeria, Oman, Qatar, Seychelles, Saint Kitts & Nevis, Saint Lucia, Saint Vincent and the Grenadines, Sierra Leone, Singapore, Sudan, Tanzania, Trinidad & Tobago, United Arab Emirate (Dubai), United Kingdom, Yemen, Zambia, Zimbabwe
13F9939	Australia, Fiji, New Zealand, Papua New Guinea
02K0545	China
36L8879	Argentina, Paraguay, Uruguay

Industry Canada Class B emission compliance statement



This Class B digital apparatus complies with Canadian ICES-003.

Cet appareil numérique de la classe B respecte toutes les exigences du Règlement sur le matériel brouilleur du Canada.

Avis de conformité à la réglementation d'Industrie Canada

Cet appareil numérique de classe B est conforme à la norme NMB-003 du Canada.

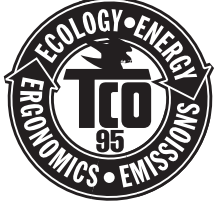
TCO Compliances Section

	Models 9512-Ax0 and 9512-Dx0 comply with TCO '95 guidelines.
	Model 9512-Ax0 and 9512-Dx0 comply with TCO '99 guidelines

Congratulations!

You have just purchased a TCO'95 or TCO'99 approved and labeled product! Your choice has provided you with a product developed for professional use. Your purchase has also contributed to reducing the burden on the environment and also to the further development of environmentally adapted electronics products.

Why do we have environmentally labeled computers?

In many countries, environmental labeling has become an established method for encouraging the adaptation of goods and services to the environment. With the growing manufacture and usage of electronic equipment throughout the world, there is a recognized concern for the materials and substances used by electronic products with regards to their eventual recycling and disposal. By proper selection of these materials and substances, the impact on the environment can be minimized.

There are also other characteristics of a computer, such as energy consumption levels, that are important from the viewpoints of both the work (internal) and natural (external) environments. Electronic equipment in offices is often left running continuously, resulting in unnecessary consumption of large amounts of energy and additional power generation. From the standpoint of carbon emissions alone, it is vital to save energy.

What does labeling involve?

This product meets the requirements for the TCO'95 or TCO'99 scheme which provides for international and environmental labeling of personal computers. The labeling scheme was developed as a joint effort by the TCO (The Swedish Confederation of Professional Employees), Svenska Naturskyddsforeningen (The Swedish Society for Nature Conservation) and Statens Energimyndighet (The Swedish National Energy Administration)

Approval requirements cover a wide range of issues: environment, ergonomics, emission of electric and magnetic fields, energy consumption and electrical safety.

Environmental criteria impose restrictions on the presence and use of heavy metals, brominated and chlorinated flame retardants, CFCs (freons) and chlorinated solvents, and other materials . The product must be prepared for recycling and the manufacturer is obliged to have an environmental policy which must be adhered to in each country where the company implements its operational policy.

Energy requirements include a demand that the computer and/or display, after a certain period of inactivity, shall reduce its power consumption to a lower level in one or more stages. The length of time to reactivate the computer shall be reasonable for the user. Labeled products must meet strict environmental demands, for example, in respect of the reduction of electric and magnetic fields as well as physical and visual ergonomics.

Below you will find a brief summary of the environmental requirements met by this product. The complete environmental criteria document may be ordered from:

TCO Development

SE-114 94 STOCKHOLM, Sweden

Fax: +46 8 782 92 07

E-mail (Internet): development@tco.se

Current information regarding TCO'99 approved and labeled products may also be obtained via the Internet, using the address: <http://www.tcodevelopment.com/>

Environmental requirements

Flame retardants

Flame retardants are present in printed circuit boards, cables, wires, casings and housings. Their purpose is to prevent, or at least to delay the spread of fire. Up to 30% of the plastic in a computer casing can consist of flame retardant substances. Most flame retardants contain bromine or chlorine, and those flame retardants are chemically related to PCBs. Both the flame retardants containing bromine or chlorine and the PCBs are suspected of giving rise to health effects, including reproductive damage in fish-eating birds and mammals, due to the bio-accumulative* processes when not disposed of in accordance with strict standards for disposal.

*Bio-accumulative is defined as substances which accumulate within living organisms.

The relevant TCO'99 demand requires that plastic components weighing more than 25 grams must not contain flame retardants with organically bound bromine or chlorine. Flame retardants are allowed in the printed circuit boards since no substitutes are available.

*Cadmium***

Cadmium is present in rechargeable batteries and in the colour-generating layers of certain computer displays.

The relevant TCO'99 requirement states that batteries, the colour-generating layers of display screens and the electrical or electronics components must not contain any cadmium.

*Mercury***

Mercury is sometimes found in batteries, relays and switches. The relevant TCO'99 requirement states that batteries may not contain any mercury. It also demands that mercury is not present in any of the electrical or electronics components associated with the labeled unit. There is however one exception. Mercury is, for the time being, permitted in the back light system of flat panel monitors as there today is no commercially available alternative. TCO aims on removing this exception when a mercury free alternative is available.

CFCs (freons)

The relevant TCO'99 requirement states that neither CFCs nor HCFCs may be used during the manufacture and assembly of the product or in its packaging. CFCs (freons) are sometimes used for washing printed circuit boards. CFCs break down ozone and thereby damage the ozone layer in the stratosphere, causing increased reception on earth of ultraviolet light. This restriction assures that further damage to the ozone layer from this type of equipment will be eliminated.

**Lead, Cadmium and Mercury are heavy metals which are bio-accumulative.

*Lead***

Lead can be found in picture tubes, display screens, solders and capacitors. The relevant TCO'99 requirement permits the inclusion of lead since no replacement has yet been developed.

**Lead, Cadmium and Mercury are heavy metals which are bio-accumulative.

ENERGY STAR® Compliances Section

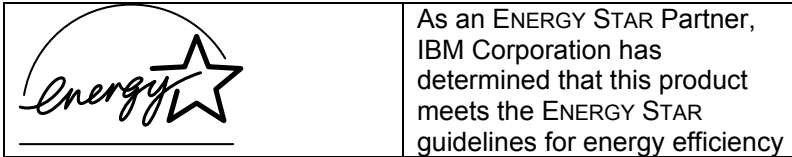

Congratulations!

You have just purchased an ENERGY STAR qualified product

What is an ENERGY STAR qualified product?

The ENERGY STAR program is a voluntary partnership between the U.S. Environmental Protection Agency / Dept. of Energy and Partners to reduce pollution and save energy. An ENERGY STAR qualified product meets or exceeds the energy criteria defined in an MOU (Memorandum of Understanding) for that product category. As an ENERGY STAR Partner, IBM offers ENERGY STAR qualified computers, monitors and printers that meet the growing performance and networking needs of customers while reducing energy use, saving you money and improving the environment.

IBM is a recognized leader in providing energy efficient office products. In 1998 and 1999, IBM received the ENERGY STAR Computer Partner of the Year award in the office equipment category and in 2001, IBM received the first ENERGY STAR Excellence in Corporate Commitment award. ENERGY STAR products save you more -- look for the ENERGY STAR label and program information on IBM products, product literature, Web sites, packaging and promotional material.

ENERGY STAR

Current criteria and information regarding the ENERGY STAR program can be found at <http://www.energystar.gov>

ENERGY STAR and the ENERGY STAR logo are registered US marks.

This product complies with Swedish National Council for Metrology (MPR) standards issued in December 1999 (MPRII) for very low frequency (VLF) and Extremely low frequency (ELF) emissions.

Electronic emission notices

Hinweise

Gemäß der Amtsblätter des BMPT Nm. 61Ú1991 und 6Ú1992 wird der Betreiber darauf aufmerksam gemacht, daß die von ihm mit diesem Gerät zusammengestellte Anlage auch den technischen Bestimmungen dieser Amtsblätter genügen muß.

Aus ergonomischen Gründen wird empfohlen, die Grundfarbe Blau nicht auf dunklem Untergrund zu verwenden (schlechte Erkennbarkeit, Augenbelastung bei zu geringem Zeichenkontrast).

Aus ergonomischen Gründen sollten nur Darstellungen auf dunklem Hintergrund bei Vertikalfrequenzen ab 60 Hz (ohne Zeilensprung) benutzt werden.

Die Konvergenz des Bildes kann sich auf Grund des Magnetfeldes am Ort der Aufstellung aus der Korrekten Grundeinstellung verändern. Zur Korrektur empfiehlt es sich deshalb, die Regler an der Frontseite für H STAT und V STAT so einzustellen, daß die getrennt sichtbaren Farblinien für Rot, Grün und Blau bei z.B. der Darstellung eines Buchstabens zur Deckung (Konvergenz) gelangen. Siehe hierzu auch die Erklärungen zu H STAT und V STAT.

European Union (EU) Statement

This product is in conformity with the protection requirements of the EU Council Directive 89/366/ECC on the approximation of the laws of the Member States relating to electromagnetic compatibility

IBM can not accept responsibility for any failure to satisfy the protection requirements resulting from a non-recommended modification of the product, including the fitting of non-IBM option cards.

This product has been tested and found to comply with the limits for Class B Information Technology Equipment according to CISPR 22 Ú European Standard EN55024:1998. The limits for Class B equipment were derived for typical residential environments to provide reasonable protection against interference with licensed communication devices.

Properly shielded and grounded cables and connectors must be used in order to reduce the potential for causing interference to radio and TV communications and to other electrical or electronic equipment. Such cables and connectors are available from IBM authorised dealers.

In accordance with EN 55024:1998 1992, Performance Criterion A:, it should be noted that in the presence of certain electromagnetic fields, some screen jitter may be observed.

Spécifications de la CEE

Ce produit est conforme aux exigences de protection de la directive 89/ 336/ EEC du Conseil de l'UE sur le rapprochement des lois des États membres en matière de compatibilité électromagnétique.

IBM ne peut accepter aucune responsabilité pour le manquement aux exigences de protection résultant d'une modification non recommandée du produit, y compris l'installation de cartes autres que les cartes IBM.

Ce produit a été testé et il satisfait les conditions de l'équipement informatique de Classe B en vertu de CISPR22 / Standard européen EN55024:1998. Les conditions pour l'équipement de Classe B ont été définies en fonction d'un contexte résidentiel ordinaire afin de fournir une protection raisonnable contre l'interférence d'appareils de communication autorisés.

Des câbles blindés et correctement reliés à la terre doivent être utilisés pour réduire les risques d'interférence avec des communications radio et télévisées, ainsi qu'avec des équipements électriques ou électroniques. Ces câbles et connecteurs sont disponibles auprès de vos revendeurs IBM agréés.

Conformément à la norme EN 55024:1998 (Critère de Performance A), l'utilisateur doit être conscient du fait qu'en présence de certains champs électromagnétiques, l'image peut être instable.

Erklärung für die Europäische Union (EU)

Zulassungsbeseinigung laut dem Deutschen Gesetz über die elektromagnetische Verträglichkeit von Geräten (EMVG) vom 30. August 1995 (bzw. der EMC EG Richtlinie 89/336):

Dieses Gerät ist berechtigt in Übereinstimmung mit dem Deutschen EMVG das EG-Konformitätszeichen - CE - zu führen.

Verantwortlich für die Konformitätserklärung nach Paragraph 5 des EMVG ist die: IBM Deutschland Informationssysteme GmbH, 70548 Stuttgart.

Informationen in Hinsicht EMVG Paragraph 3 Abs. (2) 2:

Das Gerät erfüllt die Schutzanforderungen nach EN 55024:1998 und EN55024:1998 Klasse B.

EN 55082 Hinweis:

“Wird dieses Gerät in einer industriellen Umgebung betrieben (wie in EN 55082:B festgelegt), dann kann es dabei eventuell gestört werden. In solch einem Fall ist der Abstand bzw. die Abschirmung zu der industriellen Störquelle zu vergrößern.”

Anmerkung:

Um die Einhaltung des EMVG sicherzustellen sind die Geräte, wie in den IBM Handbüchern angegeben, zu installieren und zu betreiben.

Declaración de la Unión Europea (UE)

Este producto satisface los requisitos de protección del Consejo de la UE, Directiva 89/ 336/ CEE en lo que a la legislación de los Estados Miembros sobre compatibilidad electromagnética se refiere.

IBM no puede aceptar responsabilidad alguna si este producto deja de satisfacer dichos requisitos de protección como resultado de una modificación no recomendada del producto, incluyendo el ajuste de tarjetas de opción que no sean IBM.

Este producto ha sido probado y satisface los límites para Equipos Informáticos Clase B de conformidad con el Estándar CISPR22 y el Estándar Europeo EN55024:1998. Los límites para los equipos de Clase B se han establecido para entornos residenciales típicos a fin de proporcionar una protección razonable contra las interferencias con dispositivos de comunicación licenciados.

Se deben utilizar conectores y cables debidamente protegidos y conectados a tierra a fin de reducir las posibilidades de que se produzcan interferencias con comunicaciones por radio o televisión y otros equipos eléctricos o electrónicos. Este tipo de cables y conectores pueden adquirirse en concesionarios autorizados de IBM.

De acuerdo con la norma EN 55024:1998, Performance Criterion A, habría que destacar que en presencia de determinados campos electromagnéticos, podría observarse una marcada inestabilidad e la imagen.

Dichiarazione di conformità dell'Unione Europea (EU)

Questo prodotto è conforme alle normative di protezione ai sensi della Direttiva del Consiglio dell'Unione Europea 89/ 336/ CEE sull'armonizzazione legislativa degli stati membri in materia di compatibilità elettromagnetica.

IBM non accetta responsabilità alcuna per la mancata conformità alle normative di protezione dovuta a modifiche non consigliate al prodotto, compresa l'installazione di schede e componenti di marca diversa da IBM.

Le prove effettuate sul presente prodotto hanno accertato che esso rientra nei limiti stabiliti per le apparecchiature di informatica Classe B ai sensi del CISPR 22 / Norma Europea EN55024:1998. I limiti delle apparecchiature della Classe B sono stati stabiliti al fine di fornire ra

gionevole protezione da interferenze mediante dispositivi di comunicazione in concessione in ambienti residenziali tipici.

Utilizzare cavi e connettori colle gati a terra per ridurre il rischio potenziale di interferenza delle comunicazioni radiotelevisive e di a; tri apparecchi elettrici o elettronici. I cavi sono disponibili presso i rivenditori IBM.

In accordo con quando previsto nel documento EN 55024:1998, Performance Criterion A, é importante sottolineare che in presenza di determinati campi elettroma gnetici é possibile che si verifichi un certo tremolio delle immagini.

Europeiska unionen (EU)

Denna produkt har testats och följer gränsvärdena för Klass B Information Technology Equipment enligt CISPR 22 Ú Europeisk standard EN55024:1998. Gränsvärden för Klass B-utrustning utgår från vanliga bostadsområden för att ge ett rimligt skydd mot störningar i kommunikationsenheter.

Korrekt avskärmade och jordade kablar och kontakter måste användas för att minska risken för störningar i radio- och TV-kommunikationer och annan elektrisk utrustning. Sådana kablar och kontakter finns tillgängliga hos auktoriserade IBM-återförsäljare.

I enlighet med EN 55024:1998 1992, Performance Criterion A påpekas följande: I närheten av en del elektromagnetiska fält kan vissa bildstörningar uppstår på skärmen.

Deutsche EMV-Direktive (electromagnetische Verträglichkeit)

Dieses Gerät ist berechtigt in Übereinstimmung mit dem deutschen EMVG vom 9.Nov.92 das EG-Konformitätszeichen zu führen.

Der Aussteller der Konformitätserklärung ist die IBM UK, Greenock.

Dieses Gerät erfüllt die Bedingungen der EN55024:1998 Klasse B.

이 기기는 가정용으로 전자파 적합등록을 한 기기로서
주거지역에서는 물론 모든 지역에서 사용할 수 있습니다.

VCCI Class B Notice (Japan Only)

This equipment complies with the limits for a Class B digital device (devices used in or adjacent to a residential environment) and conforms to the standards for information technology equipment that are set by the Voluntary Control Council for Interference for preventing radio frequency interference in residential areas.

この装置は、情報処理装置等電波障害自主規制協議会（VCCI）の基準に基づきクラスB情報技術装置です。この装置は、家庭環境で使用することを目的としていますが、この装置がラジオやテレビジョン受信機に近接して使用されると、受信障害を引き起こすことがあります。
取扱説明書に従って正しい取り扱いをして下さい。

Japanese statement of compliance for products less than or equal to 20 A per phase:

高調波ガイドライン適合品

Trademarks

The following terms, used in this publication, are trademarks or service marks of the IBM Corporation in the United States, other countries, or both:

HelpCenter IBM

ENERGY STAR is a U.S. Govt. registered trademark.

Microsoft, Windows, and Windows NT are trademarks of Microsoft Corporation in the United States, other countries, or both.

Other company, product, and service names may be trademarks or service marks of others.

© Copyright International Business Machines Corporation 2002. All rights reserved.