

Overview

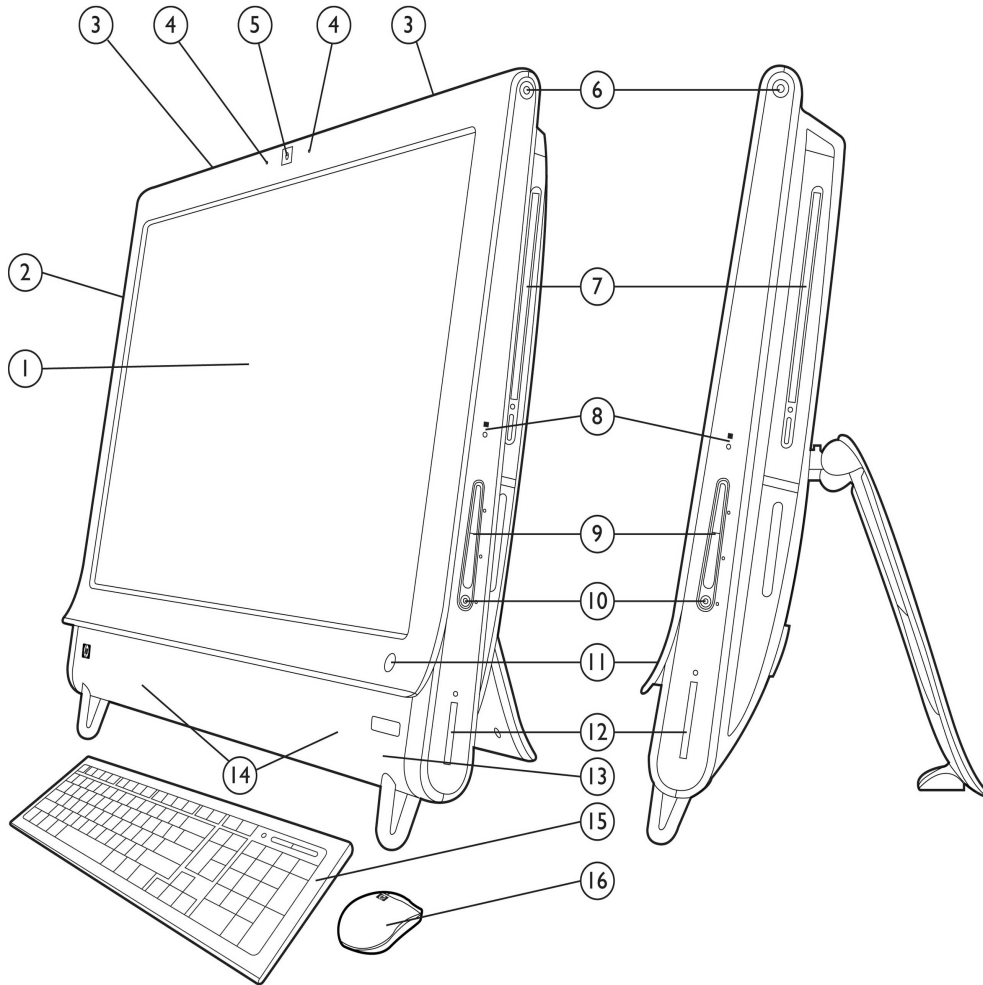

- | | |
|--|---|
| 1. Touch-enabled 23-inch diagonal widescreen BrightView LCD with tilt adjustment | 9. Volume buttons |
| 2. Bluetooth module (optional) | 10. Mute button |
| 3. Dual wireless antennas | 11. HP TouchSmart button |
| 4. Dual microphone array | 12. Memory card reader |
| 5. Webcam | 13. IR Receiver and LED (select models only) |
| 6. Power button and LED | 14. High-performance 2.0 speakers |
| 7. Slot-load optical drive (optional) | 15. HP low-profile keyboard with numeric keypad |
| 8. Drive activity LED | 16. HP optical mouse |



Overview

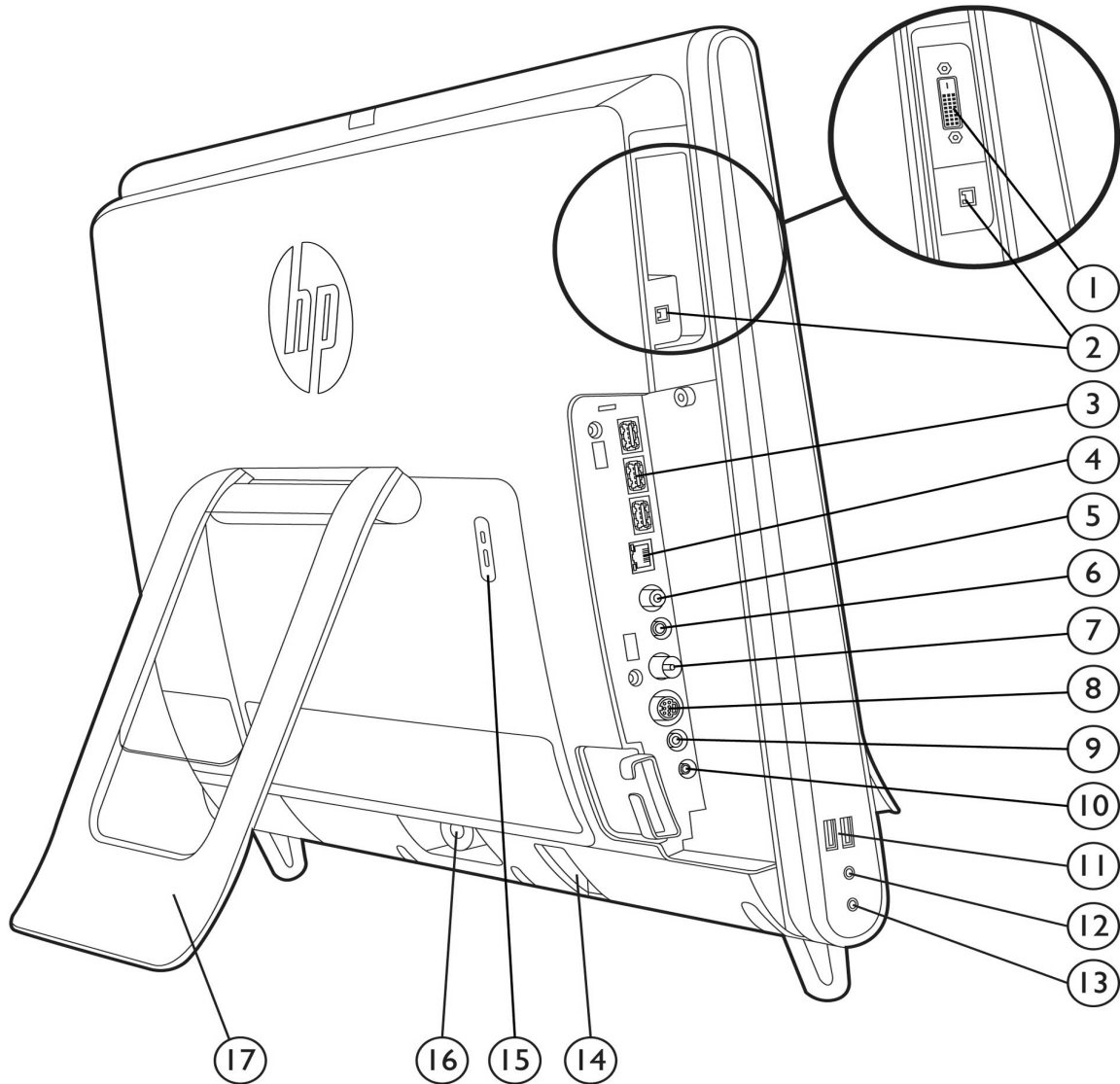

- | | |
|--------------------------------|---|
| 1. DVI-D video out | 10. IR Emitter (Blaster) output (optional) |
| 2. IEEE 1394 port | 11. (2) USB ports |
| 3. (3) USB ports | 12. Line in |
| 4. RJ-45 Gigabit Ethernet port | 13. Headphone jack |
| 5. Digital audio out (SPDIF) | 14. Optional wireless keyboard/mouse receiver |
| 6. Audio line out | 15. Kensington Lock slot |
| 7. TV coax in (optional) | 16. Power connector |
| 8. S-video input (optional) | 17. Adjustable tilt stand |
| 9. Stereo audio in (optional) | |

Overview

At A Glance

- Genuine Windows 7 Professional Edition
- Touch-enabled 23-inch diagonal widescreen BrightView LCD with glass covering
- Integrated all-in-one form factor
- Intel® Core™ 2 Duo processor, NVIDIA MCP7A-J chipset, and NVIDIA integrated or discrete graphics
- Integrated Gigabit Network Connection (10/100/1000 NIC)
- Wireless connectivity:
 - Integrated 802.11 b/g/n draft 2.0 wireless LAN module
 - Bluetooth® 2.1
- Integrated webcam, dual microphone array, and premium stereo speakers
- Optional TV Tuner
- Up to 8 GB of DDR3 SDRAM supported, dual channel memory support
- Up to 500 GB hard drive, or 64 GB Solid State Drive
- Slot-load Blu-ray Combo Drive (Blu-ray Reader/DVD Burner) or SuperMulti DVD Burner
- 6-in-1 Media Card Reader
- HP TouchSmart software suite for instant access to calendar, internet, notes, and multimedia content



Standard Features

Processors Intel Core 2 Duo Processor P7570 (2.26 GHz, 3 MB L2 cache, 1066 MHz FSB)*
Intel Core 2 Duo Processor T6570 (2.10 GHz, 2 MB L2 cache, 800 MHz FSB)*
* Intel's numbering is not a measurement of higher performance.

Operating System **Preinstalled** Genuine Windows 7 Professional Edition 64*
Genuine Windows 7 Professional Edition 32*
* System may require upgraded and/or separately purchased hardware and/or a DVD drive to install the Windows 7 software and take full advantage of Windows 7 functionality.
See <http://www.microsoft.com/windows/windows-7/> for details.

Chipset NVIDIA MCP7A-J chipset

Graphics Integrated NVIDIA GeForce G200
or
Discrete NVIDIA GeForce GT230, 1 GB

Display Touch-enabled 23-inch diagonal widescreen BrightView LCD with glass covering, tilt adjustment between 10° and 40° from vertical

Resolution	1920 x 1080 resolution (16:9)
Contrast ratio	1000:1
Image brightness	300 nits typical
Vertical viewing angle	160 degrees
Horizontal viewing angle	160 degrees

Memory **Standard** PC3-10600 DDR3 non-ECC SDRAM (runs at 1333 MHz)
Two 200-pin SODIMM slots supporting dual channel memory
2 GB (1 GB x 2)
4 GB (2GB x 2)
8 GB (4GB x 2)

Dual-channel Maximized dual-channel performance requires SODIMMs of the same size and speed in both memory slots.

NOTE: Full availability of 4 GB or more of memory requires a 64-bit operating system. With Windows 32-bit operating systems, the amount of usable memory is dependent upon your configuration, so that above 3 GB all memory may not be available due to system resource requirements.



Standard Features

Communications	Realtek 8111DL Ethernet Connection	Integrated 10/100/1000 NIC*
	802.11 PCIe Mini Wireless Module	Support for 802.11 b, g, and n Up to 300 mbps data rate Built-in dual antennas
	Bluetooth Wireless Technology (optional)	Bluetooth Specification v2.1 compliant Works with a wide range of Bluetooth devices

* The term "10/100/1000" or "Gigabit" Ethernet indicates compliance with IEEE standard 802.3ab for Gigabit Ethernet, and does not connote actual operating speed of 1 Gb/s. For high-speed transmission, connection to a Gigabit Ethernet server and network infrastructure is required.

Keyboard	Standard HP USB Keyboard	104 keys plus special keys for Mute, Volume Up, Volume Down. Separate numeric keypad. Cable length 51 in (130 cm)
	Optional HP Wireless Keyboard	104 keys plus special keys for Mute, Volume Up, Volume Down Separate numeric keypad. Operates at ~ 2.4 GHz and supports a working distance of up to 32 ft (10 m).

Pointing Device	Standard HP USB Optical Scroll Mouse	Two buttons with scroll wheel acting as third button. Cable length 69 in (175 cm)
	Optional HP Wireless Optical Scroll Mouse	Two buttons with scroll wheel acting as third button. Operates at ~ 2.4 GHz and supports a working distance of up to 32 ft (10m).

Storage	Hard Drive	3.5-inch, 7200 rpm, 3.0 Gb/s SATA Hard Drive: 250 GB 500 GB or 3.5-inch SATA Solid State Drive: 64 GB
	Optical Drive	Slot-load Blu-ray Combo Drive Read: 4x max BD-ROM, 8x max DVD-ROM, 24x max CD-ROM Write: 8x max DVD±R, 4x max DVD±R DL, 4x max DVD±RW, 5x max DVD-RAM, 16x max CD-R, 10x max CD-RW Slot-load SuperMulti DVD Burner Read: 8x max DVD-ROM, 24x max CD-ROM Write: 8x max DVD±R, 6x max DVD±R DL, 8x max DVD+RW, 6x max DVD-RW, 5x max DVD-RAM, 24x max CD-R, 24x max CD-RW Option for no optical drive



Standard Features

Interfaces	6-in-1 Media Card Reader	Supports Secure Digital (SD, SDHC), MultiMedia Card (MMC), xD-Picture Card, Memory Stick, Memory Stick Pro
	DVI-D Video out	One
	IEEE 1394 port	One
	USB 2.0	Five (2 front, 3 rear)
	Line in	One
	Audio headphone jack	One
	Audio line out	One
	Audio digital out (SPDIF)	One
	Power connector	One
	RJ-45/Ethernet	One
	IR Emitter (Blaster) out	One (with TV tuner option only)
	S-Video in	One (with TV tuner option only)
	Stereo audio in	One (with TV tuner option only)
	TV Coax connector	One (with TV tuner option only)

Audio/Visual

High Definition Audio support
Integrated high-performance 2.0 speakers
Integrated dual-microphone array
Volume control and mute buttons
Stereo headphone jack
Stereo line in
Stereo line out
Audio digital out (SPDIF)

Integrated VGA webcam
Up to 30 frames/sec
640x480 resolution
Designed for low light conditions

Optional TV Entertainment Experience (configurable)
Hybrid ATSC/NTSC, Clear QAM, Over the Air TV Tuner, HW encoded
Hybrid PAL/DVB-T, Over the Air TV Tuner, HW encoded
Hybrid PAL/DMB-T, Over the Air TV Tuner, HW encoded, Hong Kong/China
Dual channel ISDB-T/ISDB-S, Over the Air TV Tuner, HW encoded, Japan



Standard Features

Software	Preinstalled software (varies by country)	HP Power Manager HP TouchSmart Browser HP TouchSmart Calendar HP TouchSmart Canvas HP TouchSmart Clock HP TouchSmart DVD HP TouchSmart Hulu HP TouchSmart Live TV HP TouchSmart Music HP TouchSmart Video HP Touch Smart Photo HP TouchSmart Netflix HP TouchSmart RSS Reader HP TouchSmart Twitter HP TouchSmart Weather HP TouchSmart Webcam HP Total Care Advisor PDF Complete McAfee Total Protection* Microsoft Office Ready with 60-day Office Professional 2007 Trial Edition
-----------------	--	---

* 60 day trial period for McAfee Total Protection for Small Business software. Internet access required to receive updates. First update included. Subscription required for updates thereafter.

HP Power Manager	Provides real-time reporting of how system settings impact the energy consumed by the PC and the potential savings over time.
-------------------------	---

SMBIOS	System Management BIOS, previously known as DMI BIOS, is used to store system management information.
---------------	---

Security	Kensington lock
-----------------	-----------------

Power Supply	Integrated graphics: external 120-watt power supply, 87% efficiency, active PFC Discrete graphics: external 150-watt power supply, 87% efficiency, active PFC
---------------------	--



Standard Features

Service and Support

On-site Warranty^{Note 1}: One-year (1-1-1) limited warranty delivers one year of on-site, next business-day^{Note 2} service for parts and labor and includes free telephone support^{Note 3} 24 x 7. Global coverage^{Note 2} ensures that any product purchased in one country and transferred to another non-restricted country will remain fully covered under the original warranty and service offering. One-year onsite and labor are not available in all countries. To choose the right level of service for your HP product, use the HP Care Pack Services Lookup Tool at: <http://www.hp.com/go/lookuptool>. Additional HP Care Pack Services information by product is available at: <http://www.hp.com/hps/carepack>.

NOTE 1: Terms and conditions may vary by country. Certain restrictions and exclusions apply. Other warranty variations may be offered in your region.

NOTE 2: On-site service may be provided pursuant to a service contract between HP and an authorized HP third-party provider, and is not available in certain countries. Global service response times are based on commercially reasonable best effort and may vary by country.

NOTE 3: Technical telephone support applies only to HP-configured Compaq and third-party HP-qualified hardware and software. Toll-free calling and 24 x 7 support may not be available in some countries.



Options

Memory	HP 2GB DDR3-1333 (PC3-10600) SODIMM	VH640AA
	HP 4GB DDR3-1333 (PC3-10600) SODIMM	VH641AA
<hr/>		
Internal Storage	64 GB Solid State Drive	VG679AA
<hr/>		
Security	Kensington Security Lock	PC766A
<hr/>		
Miscellaneous	Belkin Promo 7-Outlet Surge Protector	AG290AA#ABA
	Belkin Network Cable	AH122AA
	Belkin Firewire (1394) Cable	AH123AA
	Belkin Starter Kit: Surge Protector, Patch Cable, Printer Cable	RT174AA
	Belkin USB to Serial Adapter	EM449AA
	Vesa Wall Mount Adapter	VK554AA



Technical Specifications

System Unit	Dimensions (HxWxD)	17.6 in x 22.8 in x 2.8 in 447 mm x 579 mm x 72 mm	
	Weight	Approx. 25.4 lb (11.5 kg)	
	Stand-Alone Power Requirements	Electrical Ratings	100–240 V, 50/60 Hz, 2.0 A
		Average Operating Power	35 W Idle
		Max Operating Power	< 150 W
	Temperature	Operating	41° to 95° F (5° to 35° C)
		Non-operating	–22° to 149° F (–30° to 65° C)
	Relative Humidity	Operating	15% to 80% @ 26° C
	Altitude (unpressurized)	Operating	0 to 6,562 ft (0 to 2000 m)
		Non-operating	0 to 15,000 ft (0 to 4,572 m)
Industry Standard Certifications	UL	Yes	
	CSA	Yes	
	FCC Compliance	Yes	
	ENERGY STAR®	Yes	
	EPEAT	Silver	

For accessibility information on HP products, please visit: <http://www.hp.com/accessibility>.

Eco-Label Certifications This product has received or is in the process of being certified to the following approvals and may be labeled with one or more of these marks:

- US Energy Star
- IT ECO declaration
- EPEAT – Silver

System Configuration The configuration used for the Energy Consumption and Declared Noise Emissions data for this desktop model is based on a typically configured product

Energy Consumption	115 VAC	230 VAC	100 VAC
Normal Operation	51.66 W	50.32 W	52.11 W
Sleep (Energy Star low power mode)	3.392 W	3.456 W	3.37 W
Off	0.557 W	0.628 W	0.555 W

Heat Dissipation*	115 VAC	230 VAC	100 VAC
Normal Operation	177 BTU/hr	172 BTU/hr	178 BTU/hr
Sleep	12 BTU/hr	12 BTU/hr	12 BTU/hr
Off	2 BTU/hr	2 BTU/hr	2 BTU/hr

* Heat dissipation is calculated based on the measured watts, assuming the service level is attained for one hour.

This product is in compliance with US executive order 13221, WOL (wake on LAN) disabled.

Declared Noise Emissions
(in accordance with
ISO 7779 and ISO 9296)



Technical Specifications

System Fan Off	Sound Power (LWAd, bels)	Sound Pressure (LpAm, decibels)
Idle	2.07	23.1
Fixed Disk (random writes)	2.41	26.0

System fan is usually off except when charging the battery

Batteries This battery(s) in this product comply with EU Directive 2006/66/EC

Batteries used in the product do not contain:

- Mercury greater the 5ppm by weight
- Cadmium greater than 10ppm by weight

Battery size: CR2032 (coin cell)

Battery type: Lithium

Additional information

- This product is in compliance with the Restrictions of Hazardous Substances (RoHS) directive - 2002/95/EC.
- This HP product is designed to comply with the Waste Electrical and Electronic Equipment (WEEE) Directive - 2002/96/EC.
- This product is in compliance with California Proposition 65 (State of California; Safe Drinking Water and Toxic Enforcement Act of 1986).
- This product is in compliance with the IEEE 1680 (EPEAT) standard at the Silver level, see www.epeat.net
- Plastics parts weighing over 25 grams used in the product are marked per ISO 11469 and ISO1043.
- This product contains 0% post consumer recycled plastic (by wt.)
- This product is 94.1% recyclable when properly disposed of at end of life.

Packaging Materials

- External:
 - Corrugated – 2292 g
- Internal:
 - Polyethylene low density foam – 39 g
 - Molded Pulp – 963 g
- The corrugated packaging material is made from 50% recycled content.
- The Molded Pulp packaging material is made from 50% recycled content.

RoHS Compliance

Hewlett-Packard is committed to compliance with all applicable environmental laws and regulations, including the European Union Restriction of Hazardous Substances (RoHS) Directive. HP's goal is to exceed compliance obligations by meeting the requirements of the RoHS Directive on a worldwide basis. By July 1, 2006, RoHS substances will be virtually eliminated (virtually = to levels below legal limits) for all HP electronic products subject to the RoHS Directive, except where it is widely recognized that there is no technically feasible alternative (as indicated by an exemption under the EU RoHS Directive).

Material Usage

This product does not contain any of the following substances in excess of regulatory limits (for reference of these limits please refer to the HP General Specification of the Environment

(http://www.hp.com/hpinfo/globalcitizenship/environment/supplychain/gen_specifications.html):

- Asbestos



Technical Specifications

- Certain Azo Colorants
- Certain Brominated Flame Retardants – may not be used as flame retardants in plastics
- Cadmium
- Chlorinated Hydrocarbons
- Chlorinated Paraffins
- Formaldehyde
- Halogenated Diphenyl Methanes
- Lead carbonates and sulfates
- Lead and Lead compounds
- Mercuric Oxide Batteries
- Nickel – finishes must not be used on the external surface designed to be frequently handled or carried by the user.
- Ozone Depleting Substances
- Polybrominated Biphenyls (PBBs)
- Polybrominated Biphenyl Ethers (PBBEs)
- Polybrominated Biphenyl Oxides (PBBOs)
- Polychlorinated Biphenyl (PCB)
- Polychlorinated Terphenyls (PCT)
- Polyvinyl Chloride (PVC) – except for wires and cables, and certain retail packaging has been voluntarily removed from most applications.
- Radioactive Substances
- Tributyl Tin (TBT), Triphenyl Tin (TPT), Tributyl Tin Oxide (TBTO)

Packaging

HP follows these guidelines to decrease the environmental impact of product packaging:

- Eliminate the use of heavy metals such as lead, chromium, mercury and cadmium in packaging materials.
- Eliminate the use of ozone-depleting substances (ODS) in packaging materials.
- Design packaging materials for ease of disassembly.
- Maximize the use of post-consumer recycled content materials in packaging materials.
- Use readily recyclable packaging materials such as paper and corrugated materials.
- Reduce size and weight of packages to improve transportation fuel efficiency.
- Plastic packaging materials are marked according to ISO 11469 and DIN 6120 standards.

End-of-life Management and Recycling

Hewlett-Packard offers end-of-life HP product return and recycling programs in many geographic areas. To recycle your product, please go to: <http://www.hp.com/go/reuse-recycle> or contact your nearest HP sales office. Products returned to HP will be recycled, recovered or disposed of in a responsible manner.

The EU WEEE directive (2002/95/EC) requires manufacturers to provide treatment information for each product type for use by treatment facilities. This information (product disassembly instructions) is posted on the Hewlett Packard web site at: <http://www.hp.com/go/recyclers>. These instructions may be used by recyclers and other WEEE treatment facilities as well as HP OEM customers who integrate and re-sell HP equipment.

Hewlett-Packard Corporate Environmental Information

For more information about HP's commitment to the environment:

Global Citizenship Report

<http://www.hp.com/hpinfo/globalcitizenship/gcreport/index.html>

Environment website

<http://www.hp.com/environment>

Eco-label certifications

<http://www.hp.com/hpinfo/globalcitizenship/environment/productdesign/ecolabels.html>

ISO 14001 certificates:

<http://www.hp.com/hpinfo/globalcitizenship/environment/>



Technical Specifications

[operations/envmanagement.html](#)

Copyright © 2011 Hewlett-Packard Development Company, L.P.

All rights reserved. Microsoft, Windows and Windows 7 are registered trademarks or trademarks of Microsoft Corporation in the U.S. and/or other countries. Core 2 Duo is a trademark of Intel Corporation in the U.S. and/or other countries. Bluetooth is a registered trademark of Bluetooth SIG, Inc., in the U.S. and other countries. All other product names mentioned herein may be trademarks of their respective companies.

The information contained herein is subject to change without notice and is provided "as is" without warranty of any kind. The warranties for HP products are set forth in the express limited warranty statements accompanying such products. Nothing herein should be construed as constituting an additional warranty. HP shall not be liable for technical or editorial errors or omissions contained herein.

