

B9

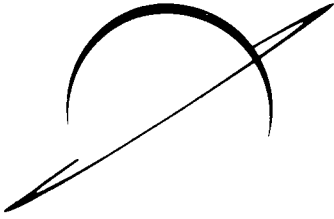

INSTRUCTION BOOK DEPT.
LIBRARY
MASTER COPY

ZANUSSI

Instructions for the use and care of GC 17 cooker

B9

It is most important that this instruction book should be retained with the appliance for future reference. Should the appliance be sold or transferred to another owner, or should you move house and leave the appliance, always ensure that the book is supplied with the appliance in order that the new owner can be acquainted with the functioning of the appliance and the relevant warnings.

Warnings – Gas cookers

THESE WARNINGS ARE PROVIDED IN THE INTEREST OF SAFETY. YOU MUST READ THEM CAREFULLY BEFORE INSTALLING OR USING THE APPLIANCE.

- This appliance is designed to be operated by adults. Children should not be allowed to tamper with the controls or play with the product.
- Any installation work must be undertaken by a competent, qualified installer in accordance with the Gas Safety (Installation and Use) Regulations 1984 and the relevant codes of practice. In the U.K. C.O.R.G.I. registered installers (including regions of British Gas) undertake the work to safe and satisfactory standards.
- Any electrical work required to install this appliance should be carried out by a qualified electrician.
- It is dangerous to alter the specifications or modify the product in any way.
- Under no circumstances should any maintenance work be carried out by any other than a qualified person.
- This product should be serviced by an authorised Zanussi Network Service Centre, and only genuine Zanussi spare parts should be used.
- Unstable or misshapen pans should not be used on the burner as unstable pans can cause an accident by tipping or spillage.
- Cookers and hobs become very hot with use, and retain their heat for a long period of time after use. Children should be supervised at all times and should not be allowed to touch the hot surfaces or be in the vicinity when in use or until the appliance has cooled after use.
- If the appliance is fitted with a lid, this is designed as a dust cover when closed, and as a splash-back when open. Do not use for any other purposes.
- It is always necessary to remove any spillage from the surface of the cover before removal or opening (if applicable), and the appliance should be allowed to cool before replacing or closing the cover.
- This product should only be used with natural gas.
- Always ensure that the control knobs are in the «off» position when not in use.
- All gas appliances require adequate ventilation. Failure to provide this could result in a lack of oxygen. Your installer will advise if in doubt.
- For hygiene and safety reasons, this appliance should be kept clean at all times. A build-up of fats or other foodstuffs could result in a fire.
- This product has been designed for cooking edible foodstuffs only, and must not be used for any other purposes.
- Always ensure that the oven vent which is located at the centre back of the hob is left unobstructed to ensure ventilation of the oven cavity.
- A gas oven relies on the movement of air for heating. Under no circumstances should the vents in the base of the oven be obstructed. Never line any part of the oven with aluminium foil.
- Do not allow the oven cavity to fill with unlighted gas.
- This appliance is heavy and care must be taken when moving it.
- Before any maintenance or cleaning always unplug the appliance from the electrical supply, and allow to cool.
- Before igniting the oven or grill, open the oven door.
- Ensure that oven anti-tip shelves are put in place in the correct way. (See instructions).
- Under no circumstances should gas cookers and hobs be left unattended when in use.
- Easy clean liners should never be cleaned with anything other than soapy water. (See instructions regarding cleaning).
- When operating a burner, the grill or oven, make sure that the gas is fully ignited.
- Only oven-proof dishes are to be stored in the drawer beneath the oven. Do not store combustible materials.
- Under no circumstances should you attempt to repair the appliance yourself. Repairs carried out by unauthorised or inexperienced persons may cause injury or more serious malfunctioning. Refer to your local Zanussi Network Service Centre. Always insist on genuine Zanussi spare parts.

Contents

Instructions for the owner

Installation	Page 3
Technical data	Page 3
Use	Page 4
Gas oven.	Page 6
Cooking procedure	Page 9
Maintenance & cleaning	Page 10

Instructions for the installer

Installation	Page 12
Electrical connection	Page 14
Gas connection	Page 15
Replacing the nozzles	Page 15
Adjusting the air	Page 17
Adjusting the minimum	Page 17
Maintenance.	Page 18

Caution:

Before you start operating the appliance, be sure to remove the plastic films protecting the stainless steel or anodized aluminium parts.

Important: During normal cooking operations the appliance will get very hot. Therefore, do not let children play near the appliance.

Instructions for the owner of the appliance

Installation

It is mandatory that all operations required for the installation, the adjustments, the conversion to the type of gas available etc. be carried out by **QUALIFIED PERSONNEL** in accordance with existing rules and regulations.

The relevant instructions are to be found in the special chapter for the installer.

This appliance meets the requirements laid down in EEC Directive No 82/499 dated 7/6/1982 relating to the suppression of radio and TV interference.

Technical data

Model		GC 17
Dimensions: height	mm	900
depth	mm	598
width	mm	597
Oven volume	dm ³	53
Automatic lighting: worktop		YES
Safety (Thermocouple): oven and grill		YES
Oven lamp		YES
Supply voltage (240V - 50Hz)		YES

Care and use

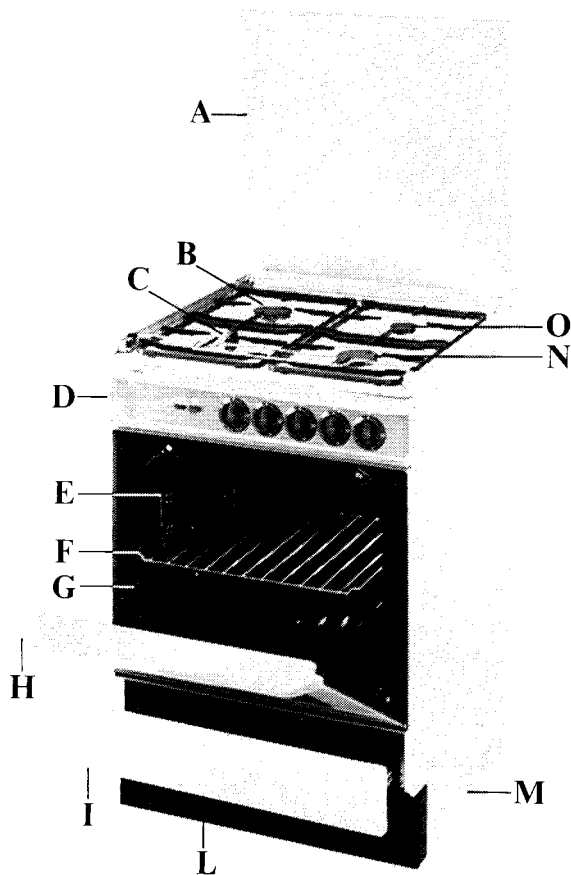

Cooker

- A - Cover
- B - Rapid burner
- C - Auxiliary burner
- D - Control panel
- E - Side grilles
- F - Grilles
- G - Dripping pan
- H - Oven door
- I - Removable drawer
- L - Front panel
- M - Removable base
- N - Rapid burner
- O - Semi-rapid burner

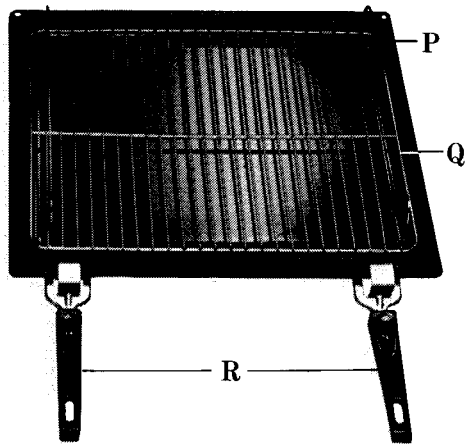

- P - Grill or roasting pan
- Q - Reversible grill pan insert
- R - Removable handles (2 Off.)

Control panel

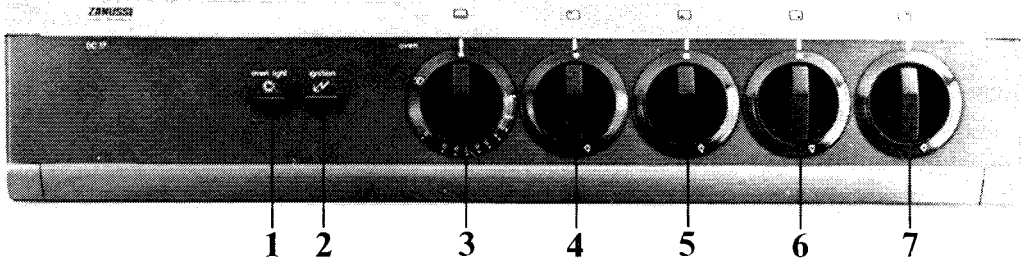

1. Oven light switch
2. Lighting button
3. Oven knob
4. Rapid burner knob
5. Auxiliary burner knob
6. Rapid burner knob
7. Semi-rapid burner knob

Operation

Worktop burners

To light a worktop burner, turn the relevant knob anticlockwise to maximum (Fig. 1).

After opening the tap to maximum, push button marked by a small electric spark. As soon as the burner is lit, adjust the flame as required.

To ensure maximum burner efficiency, it is strongly recommended that you use only pots and pans with a bottom fitting the size of the burner used, so that the flame will not spread beyond the bottom of the vessel.

It is also advisable, as soon as a liquid starts boiling, to turn down the flame so that it will barely keep the liquid simmering.

Important: Be very careful when frying food in hot oil or fat as the overheated splashes could easily flare up.

Gas oven

The oven features an enamelled dripping-pan to collect the gravy when grilling or spit-roasting meat, and a shelf to grill food or to cook it in baking-tin.

Furthermore this oven fits a device which makes the ignition of the burner easier. The instructions are the following:

1.

Open the door, strike a match and hold it close to the hole at the right side of the small lid which is in the front part of the oven bottom (fig. 2).

2.

Firmly depress the oven control knob and turn it anticlockwise to the maximum setting. Keep the oven control knob depressed for 10-15 secs.

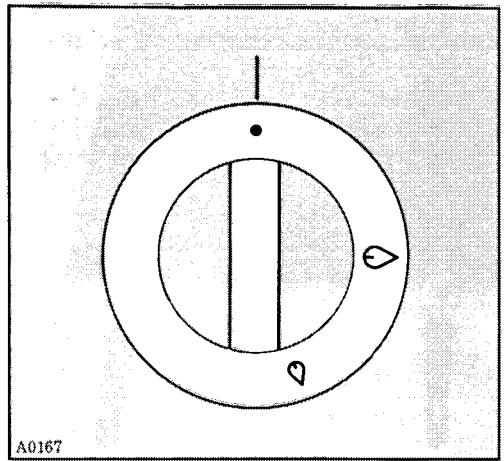

A0167

Fig. 1

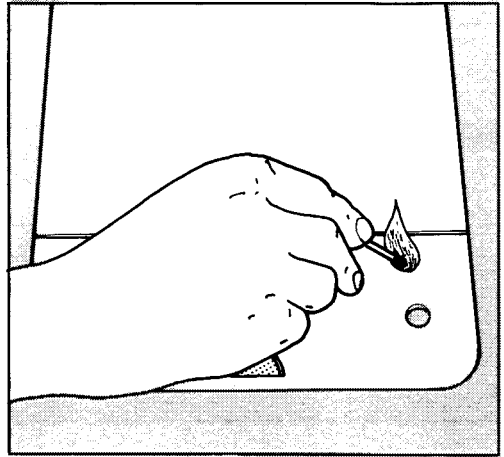

Fig. 2

Oven temperature chart

Position	Temperatures	
	°F	°C
1	275	135
2	300	149
3	325	163
4	350	177
5	375	191
6	400	204
7	425	218
8	450	232
9	475	246
h	527-536	275-280

3.

Release the control knob and then gently close the oven door.

To adjust the temperature, after a few minutes turn the knob to the required temperature setting (Fig. 3).

Gas grill

To light the grill, strike a match and hold it close to the grill burner then firmly depress the oven control knob and turn it clockwise to symbol .

Keep the control knob depressed for 10-15 secs.

Oven safety device

The cooker features a thermocouple; if for any reason the flame should extinguish the device will interrupt the gas flow.

Important:

Oven and grill burner lighting is possible only if the oven door is opened.

Pot safeguard (Fig. 4)

A particular joint system allows to fix the pot guard in its vertical working position and in the horizontal (resting) position as well.

To lift the pot guard: push forwards and rotate it at the same time.

To lower it: lift upwards and rotate it reversely.

Oven light switch

This switch will turn on the oven light.

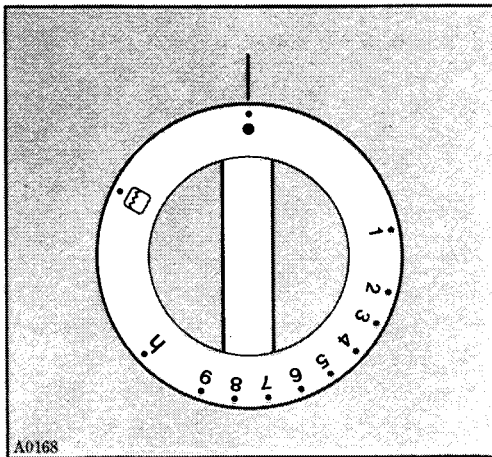

A0168

Fig. 3

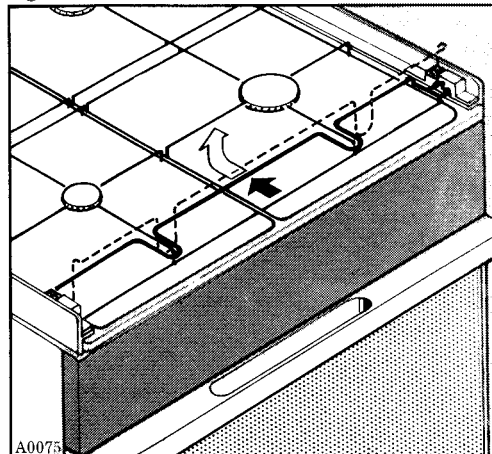

A0075

Fig. 4

Using the grill

Foods to be grilled are to be placed on the wire grid in the grill pan which can be curved either upwards or downwards to give the required distance from the grill burner.

The pan is then placed in the required runner position.

Important: Because the grill is in the top of the oven, the door must be left ajar when grilling. This means that the escaping heat from the grill could overheat the control panel, so to prevent this happening it is essential that the heat deflector provided to protect the appliance is in place before the grill is turned on.

The deflector is put in place as shown in Fig. 5.

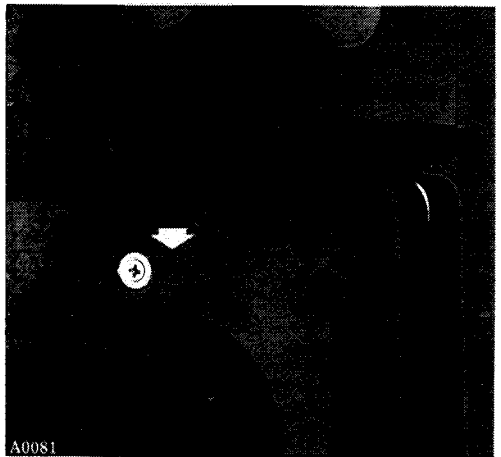

A0981

Fig. 5

Hints for a correct use of the oven and the grill

After turning on the oven and prior to introducing the food, it is advisable to wait for about 10 to 15 minutes to allow the oven to reach the required temperature. In the case of dishes requiring a high initial temperature or a stabilized temperature at the centre of the oven, the above preheating time will have to be increased

The food to be cooked should be placed on the oven shelf, dripping-pan (roast meat) or in a baking-tin placed on the shelf. To obtain a uniform cooking, it is advisable to use the oven lower or middle runner.

Experience will tell which is the most suitable position in each case depending on the cooking requirements.

Whipped up kneadings have the required firmness when they tend to stick to the spoon as, otherwise, an excessive fluidity would uselessly stretch the cooking time. Shortbread kneadings should first be baked in the mould on the baking-tin for about two-thirds of the total baking time, and then be garnished (trimmed) before you complete the baking.

This final baking time depends on the type and quantity of the garniture (trimmings). Gourmets greatly appreciate grilled food as it usually remains very tender and savoury. All meats are suitable for grilling, with the exception of some lean game meats and meat-loaves.

The meat must be thoroughly drained, i.e. kept until it becomes high (tender).

The pieces of meat to be cooked should not weigh less than 1 Kg. boneless.

If bones are removed beforehand, this will shorten the cooking time and it will be easier to cut the meat. Meat needs to be turned over only if cooking is done at higher temperatures.

Ingredients for the gravy should be placed in the baking-tin straightaway if cooking is to be short. If cooking is to last long, instead, these ingredients are to be added during the last half-hour.

To find out if the meat is done, press it down with a spoon.

If it is well done the meat should not give in (yield). When the meat is done to a turn, the gravy is grayish in colour. Cooking time for roast-beef and fillet, the inside of which should remain of a pink colour, is reduced.

Wait for at least 15 minutes before cutting the meat, so that the dish gravy (meat juice) may settle down instead of dripping out profusely.

The dish can be kept warm in the oven with the thermostat turned off.

Maintenance

For a long service life of the appliance we strongly recommend that you frequently carry out a thorough cleaning operation.

Cleaning the oven

(without panels)

Always wait until the oven is cool before cleaning.

It is advisable to release the oven side rails.

All enamelled parts should be washed with lukewarm water and detergent without using abrasive products which might damage them.

The oven should be cleaned inside with the greatest care, after each use, with hot water and detergent (or one of the special products available on the market).

When cleaning the oven, be careful to protect the aluminium parts of the control panel from chemical compounds contained in the products used to clean the enamelled parts.

Removing the panels (optional)

Unscrew the ring nuts securing the side grilles (Fig. 6), remove the grilles and then remove the side panels (Fig. 7).

Cleaning the worktop

Burner caps should be frequently washed in hot water and detergent, being careful to remove all incrustations.

Thoroughly clean the terminal part to prevent a difficult lighting and, furthermore, make sure that the flame spreader gas openings are unobstructed. Stainless steel parts should be carefully rinsed with water, after each use, and then dried with a clean soft cloth or with a buckskin.

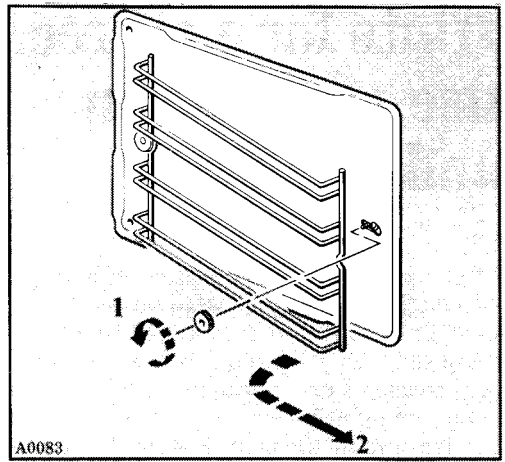

A0083

Fig. 6

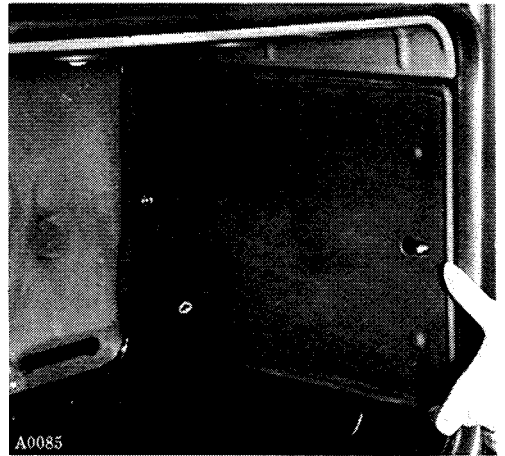

A0085

Fig. 7

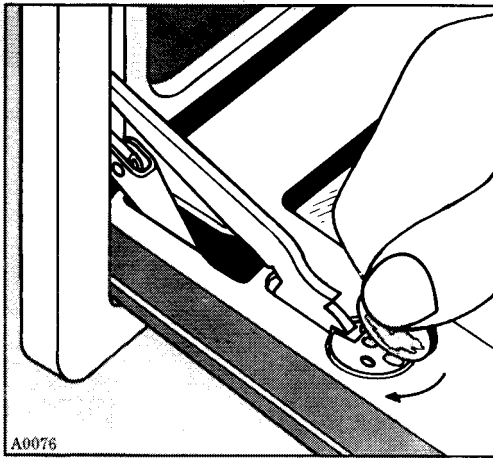

A0076

Fig. 8/A

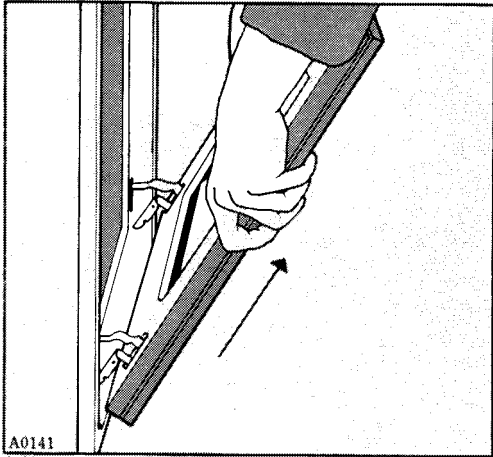

A0141

Fig. 8/B

In the case of persistent spots you may use normal non-abrasive detergents, currently available on the market, or some hot vinegar.

Never use steel-wool pads, chlorine or similar products which might scratch, grind or etch the metal.

Also, never close the cover while the burners are still warm.

Replacing the oven lightbulb

Disconnect the appliance from the electric supply.

Unscrew the lightbulb glass protection from the oven. Unscrew the lightbulb and replace it with a new bulb suitable for high temperature (300 °C) and having the following technical features:

Operating voltage: 240V - 50Hz

Power absorbed: 15 W

Removing the oven door

(Fig. 8 A-B)

To thoroughly clean the oven you should remove the door by proceeding as follows:

1.

With the aid of a coin, turn the oven door stops (catches) 45° to the right.

See Fig. 8/A.

2.

Raise the door to the limit stop and pull it out in a forward direction.

Grasp the door on the two sides- don't pull it by the handle. See Fig. 8/B.

Instructions for the installer

Installation

The following instructions are meant for a qualified installer and should assist him in carrying out all installation, adjustment and maintenance operations in the most correct way and in accordance with existing laws and regulations.

Important:

Before servicing the appliance or undertaking any maintenance work on it, be sure to disconnect it from the electric supply. Should it be absolutely necessary to keep the appliance 'live' take all possible precautions to prevent accidents.

Positioning

To ensure a troublefree operation of the appliance, it is a must that it be set up in a well ventilated kitchen (in this connection, the installer needs only comply with existing rules and regulations). The cooker may be positioned in such a way as to come into touch with the sides of the kitchen furniture. However, the latter must be able to withstand a temperature increase of 60 °C.

The appliance incorporates a removable base (A - Fig. 9-10) which permits the alignment with kitchen furniture having a height of 85 cms, plus levelling feet (B - Fig. 9-10).

To remove the metal base rest the appliance on a side, slide out the front plastic panel (C - Fig. 9) which is push-fitted and then unscrew the six screws (D - Fig. 9) that secure the base to the cabinet.

Remove the levelling feet from the base (B - Fig. 9-10), screw them onto the cabinet and then fit the new front panel (optional) (E - Fig. 10).

Position the appliance.

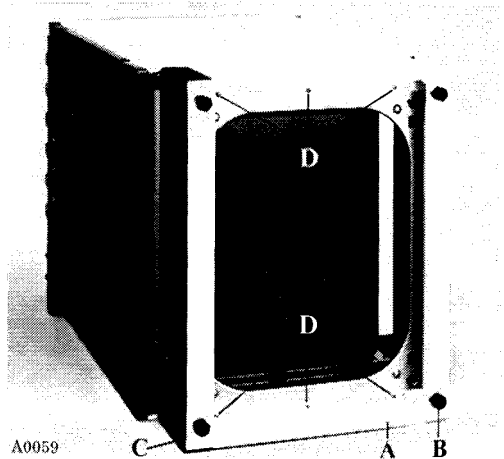

A0059
Fig. 9

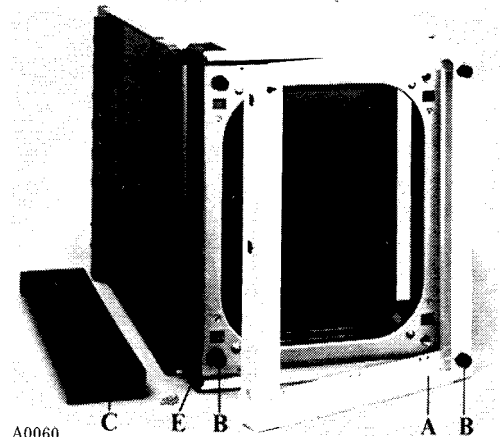

A0060
Fig. 10

The appliance incorporates a set of adjustable feet.

By properly adjusting the feet, the appliance can be set up at the required height and correctly aligned with the kitchen furniture or any other surface, thus ensuring an even spreading out of liquids in pans and pots.

These adjustable feet are easily accessible after removing the dish-warming drawer. To remove this drawer, proceed as follows:

- pull out the drawer to the limit stop in order to slide out completely the side runners;
 - shift the front rollers up to the "buttonholes" of the side runners;
 - lift up the drawer and slide out the front rollers;
 - pull out the drawer and shift the rear roller up to the "buttonholes" of the side runners;
 - lift up the drawer and slide out the rear rollers;
- To replace the drawer, reverse the above procedure.

Alignment of the worktop

To allow the alignment with the kitchen unit, the worktop frames are removable: Remove the two screws (A - Fig. 11) fixing the gasket (E - Fig. 11) placed on the back of the worktop and then slide out the gasket;

Remove the two cover shock absorbers (B - Fig. 12);
Loosen the four screws (C - Fig. 12) fixing the side frames (D - Fig. 12) to the worktop; Slide forward the two side frames (D - Fig. 12);

Block the side frames (D - Fig. 12) by means of the four screws (C - Fig. 12) to the worktop;
Refit the cover shock absorbers (B - Fig. 12);
Fit the gasket (E - Fig. 13) on the front side of the worktop and fix it by means of the two screws (A - Fig. 13).

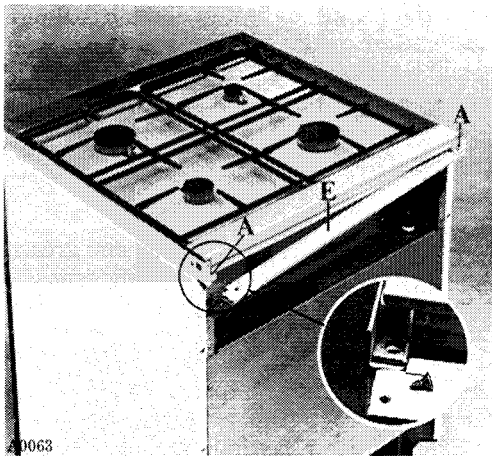

A0063
Fig. 11

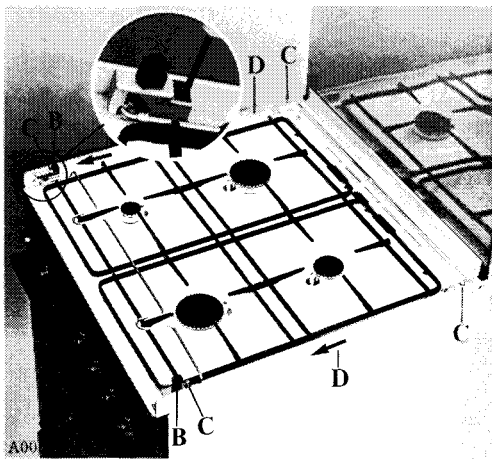

A000
Fig. 12

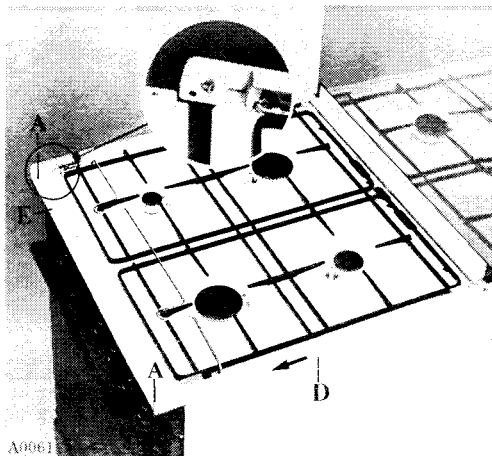

A0061
Fig. 13

Electrical connection

The appliance features a three-pole electric supply cable, having a plug with fuse, and is designed to operate on alternating current, with a single phase voltage of 240 V - 50 Hz.

The ground wire is green & yellow coloured.

The oven features an easily accessible terminal board with the following markings:

L = Live N = Neutral \perp = Earth

Connecting the supply cable to the mains

Insert the plug into a standard wall socket suitable for the load shown on the rating plate.

If you require a direct connection to the electric network (mains), it will be necessary to fit between the cooker and the mains an omnipole switch, with a minimum aperture between contacts of 3 mm, suitable to carry the required load and conforming to the ruling specifications.

The green & yellow ground wire must not be interrupted by the switch.

The supply cable must at any rate be placed in such a way as to ensure that it does not reach at any given point a temperature 50 °C higher than the ambient temperature.

Prior to connecting the cooker to the electricity supply make sure that:

the protection fuse and the domestic wiring are suitable to carry the total electric load of the cooker (see rating plate):

the electricity supply network (mains) has an efficient earth connection according to the established rules and existing regulations;

with the cooker definitely installed, the wall socket or the omnipole switch can easily be reached.

The Manufacturer disclaims any liability in case these accident-preventing rules are not observed.

Important

The heat insulation of the oven and grease residues from the manufacturing process produce smoke and an unpleasant smell during the first minutes of operation.

It is therefore advisable, the first time the appliance is used, to pre-heat the oven for about 30 mins. at peak temperature without putting any food into it.

Gas connection

Connect the cooker to the gas bottle or gas mains, in accordance with existing rules and regulations, only after making sure that the appliance has been duly adapted to the type of gas available. Otherwise, carry out all operations according to the directions to be found under the paragraph "Conversion to other types of gas".

Important: To ensure a safe operation, a lower consumption and a longer service life of the appliance, make sure that the feed pressure is in accordance with the specifications given in the "burner and nozzle features" chart.

Stiff connection

In case of connection to the gas mains by means of a metal pipe & fittings, make sure that this does not put any strain on the appliance.

The cooker has a 1/2" threaded gas inlet.

Burner and Nozzle Features Chart

Burner	Nominal Power		Liquid gas		Natural gas (Methane)	
	Kc	kW	Nozzle	g/h	Nozzle	l/h 15°C
Small (dia. 35 mm)	700	0,8	47	59	65	77
Medium (dia. 50 mm)	1400	1,6	63	118	86	155
Big (dia. 75 mm)	2600	3,0	85	219	117	288
Oven	2600	3,0	85	219	125	288
Grill	2500	2,9	85	211	125	277
Feed Pressure	nom. (mbar)*		28		20	
	min. (mbar)*		20		18	
	max. (mbar)*		35		25	

*1 mbar = 10 mm water column

Conversion to other types of gas

Attention: The cooker is adjusted for NATURAL GAS (METHANE).

To adapt the cooker to a type of gas different from the one for which it is adjusted, perform the following operations in the order.

Replacing the nozzles (see chart)

Remove the pot-rests and the burners; undo the screws securing the worktop, lift it up (to keep it raised, use the special supporting rod located on the mounting of the left-hand burners), unscrew the nozzles and replace them with the corresponding nozzles (supplied with the cooker) suitable for the new type of gas.

Refit the parts reversing the above procedure.

Taps

Burner	Dia. Tap By-Pass	Tap colour
Small	30	Red
Medium	32	Yellow
Big	42	Black

Oven Thermostat

By-pass Pin Dia.	Liquid gas	Natural gas
	0,47	0,70

Oven burner

Undo the securing screw and remove the oven bottom; from inside the dish-warming drawer unscrew the wing nut securing the bracket carrying the spark plug and the thermocouple as well as the one to be found in the front part of the burner; then push the burner itself forwards. Unscrew the nozzle and replace it with the corresponding new nozzle. Refit the parts reversing the above procedure.

Grill burner

Unscrew the two screws locking the burner to the bracket (Fig. 14), then remove the burner by lowering it and pulling it forward. Unscrew the nozzle and replace it with the corresponding new nozzle. Refit the burner reversing the above procedure.

Oven Thermostat

Remove the control knob and replace the by-pass pin fitted on the top of the knob shaft with the corresponding one suitable for the new type of gas.

Adjustments

Adjusting the primary air

Light the burners and check the flame. If the primary air needs to be adjusted, set the sliding sheet-iron ring to be found at the entrance of the burner's Venturi tube. By adjusting this ring it is possible to obtain a steady flame with a correct air-gas mixture (see Fig. 15 a/b/c).

Adjusting the minimum flame setting

Worktop burners

Turn the gas tap to minimum, remove the control knob and with a screwdriver turn the adjusting screw, which is inside the gas tap shaft, until a small and steady flame is obtained. Check stability of flame by quickly turning the tap from max. to min., re-adjusting the flame if necessary.

Attention: If the cooker is adjusted for Methane gas, to convert it to Liquid gas it will suffice to screw completely in the minimum adjustment screw, after changing the main jets.

Oven burner

After keeping the oven in operation for about 10 minutes on the max. setting with the oven door closed, turn the thermostat to position 1, remove the control knob and then adjust the screw on top of the control knob shaft until a steady flame of the right size is obtained.

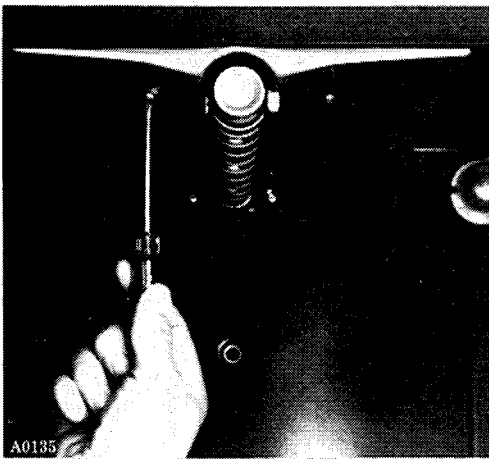

A0135

Fig. 14

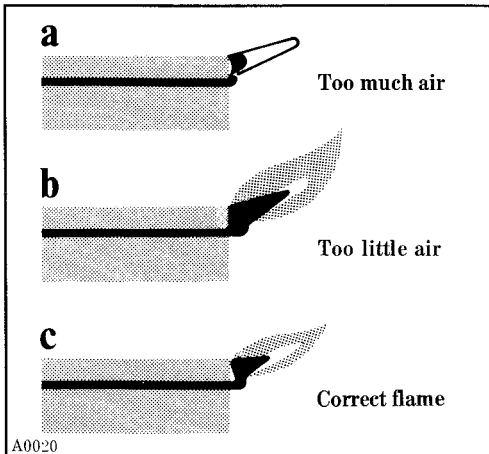

A0020

Fig. 15

Maintenance

Check at regular intervals the condition and serviceability of the gas connection hose and pressure regulator, if any; in case of malfunction, do not repair but replace the whole faulty part.

To ensure a smooth and safe operation, it is necessary to periodically grease the gas taps.

Servicing should be carried out as follows: remove the knobs and slide out the front panel after removing the securing screws. Unscrew the two screws to be found next to the gas tap shaft.

Slide out the cone and clean it thoroughly; finally, apply a thin layer of grease of a type non-soluble to hydrocarbons and suitable for gas taps.

Make sure that no excess grease obstructs the gas tap holes.

Refit everything very carefully reversing the above procedure.



ZANUSSI STANDARD GUARANTEE CONDITIONS

This guarantee is in addition to your statutory and other legal rights which will not be excluded or in any way diminished by the return of the guarantee card.

We, Zanussi Limited, undertake that if, within twelve months (24 months for TV sets) of the date of the purchase, this ZANUSSI appliance or any part thereof is proved to be defective by reason only of faulty workmanship or materials, we will, at our option, repair or replace the same **FREE OF ANY CHARGE** for labour, materials or carriage on condition that:

—The appliance has been correctly installed and used only on the electricity supply stated on the rating plate.

—The appliance has been used for normal domestic purposes only, and in accordance with the manufacturer's operating and maintenance instructions.

—The appliance has not been serviced, maintained, repaired, taken apart or tampered with by any person not authorised by us.

—The appliance is still in the possession of the original purchaser.

All service work under this guarantee must be undertaken by a Zanussi Network Service Centre (or the Zanussi Authorised TV Service Dealer).

Any appliance or defective part replaced shall become our property.

Exclusions

This guarantee does not cover:

—Damage or calls resulting from transportation, improper use or neglect, the replacement of any light bulbs or removable parts of glass or plastic.

—Costs incurred for calls to put right machines improperly installed or calls to machines outside the UK and the Republic of Ireland.

—Appliances found to be in use within a commercial environment, plus those which are the subject of rental agreements.

—Television receivers - routine adjustment, or poor reception resulting from a source outside of the receiver.



ZANUSSI 5 YEAR COVER CONDITIONS

For a once-only payment you can extend your Standard Guarantee to 5 years. All the conditions and exclusions of the Standard Guarantee apply.

Notes

1. Products supplied as "seconds", refurbished, damaged or shop-soiled are not eligible for Zanussi 5 year cover.
2. The issue of a cover does NOT by virtue of our having done so, nullify the exclusions.
3. The Engineer will need to check the details of your Cover card and may make a charge for his services if it is not presented to him at the time of his call.
4. The date of purchase, or the date of initial payment (deposit) of the appliance will be deemed the date of commencement of cover.
5. Covers issued are not refundable or transferable.

ZANUSSI
The appliance of science