



# Air Conditioner

## Owner's Manual

### Standard and Easy Mount

**Cool Only:** AJCS 06 LZ

AJCS 08, 10 AZ

**Heat/Cool:** AJES 06 LS

AJES 08 AS

AJES 10 DS

**Heat Pump:** AJHS 08 AS

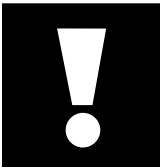

## Important Safety Information

3

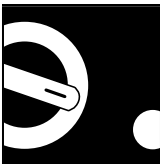

## Operating Instructions

*The Controls on Your Air Conditioner  
Care of Product*

4



## Installation Instructions

*Important Electrical Safety  
Window Installation  
Through-the-Wall Installation*

8

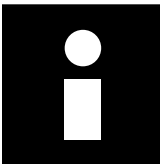

## Helpful Information

*Things That Are Normal*

24



## If Something Goes Wrong

*Before You Call for Service  
GE Service Numbers  
Warranty*

25

**GE Answer Center®**

**800.626.2000**

*GE Appliances*

## Welcome

Welcome to the GE family. We're proud of our quality products and we believe in dependable service. You'll see it in this easy-to-use manual and you'll hear it in the friendly voices of our customer service department.

Best of all, you'll experience these values each time you enjoy the comfort of your air conditioner. That's important, because your new air conditioner will be part of your family for a long time.

## Start Here!...Before using your air conditioner

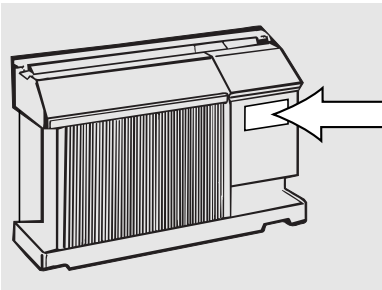

**Write down the model and serial numbers here.** They are on a label on the front of the control box behind the front grille.

---

**Model number**

---

**Serial number**

---

**Date of purchase**

**Staple your receipt to the inside back cover of this manual. You will need it to obtain service under warranty.**

## Need Help?

*Help us  
help you*

**800.626.2000**

Before you call for service, there are a few things you can do to help us serve you better.

**Read this manual.** It contains instructions to help you use and maintain your air conditioner properly.

**Save time and money.** Check the section titled "If Something Goes Wrong" before calling. This section helps you to solve common problems that might occur.

If you do need service, you can relax knowing help is only a phone call away. A list of toll-free customer service numbers is included in the back of this book. Or call the GE Answer Center<sup>®</sup> at 800.626.2000, 24 hours a day, 7 days a week.

## IMPORTANT SAFETY INFORMATION

### READ ALL SAFETY INFORMATION BEFORE USING



- This air conditioner must be properly installed in accordance with the Installation Instructions before it is used.
  - Repair or replace immediately all electric service cords that have become frayed or otherwise damaged.
  - Turn the mode control to **OFF** and unplug your air conditioner before making any repairs.
- NOTE:** We strongly recommend that any servicing be performed by a qualified individual.

#### Extension Cord

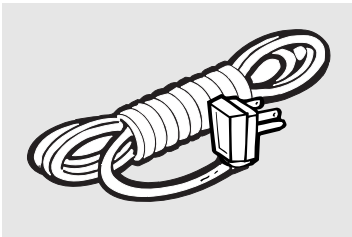

The use of an extension cord is not recommended. However, if an extension cord is required to reach the nearest wall receptacle, use only a UL-listed, 3-wire, grounded, 14 gauge, 15A, 125V appliance extension cord.

#### **CAUTION:**

**DO NOT use an extension cord with any of the 208/230-volt models.**

#### Adapter Plug

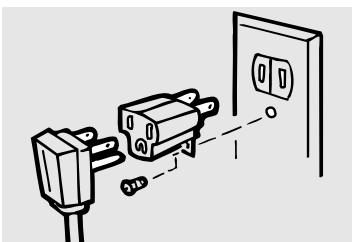

This is a temporary method. UL-listed adapters are available at most hardware stores.

Because most 2-prong outlets are not grounded, we strongly advise against using an adapter plug. However, a temporary connection may be made where local codes permit and if the 2-prong wall outlet is properly grounded.

When you plug the adapter in, make sure the larger prong goes into the larger slot to provide the proper polarity for the power cord.

#### **FOR PROPER GROUNDING:**

- 1 Screw the adapter to the outlet, using the outlet cover screw.**
- 2 Ground the outlet through the house wiring.**

When disconnecting the power cord from the adapter, hold the adapter close to the outlet while pulling the plug out. If this is not done, the grounding connector is likely to break with repeated use.

If the grounding connector breaks, **DO NOT USE** the air conditioner until a proper ground has again been made.

## SAVE THESE INSTRUCTIONS

# Operating Instructions

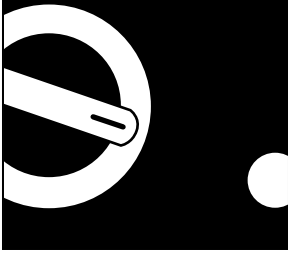

The controls on your air conditioner

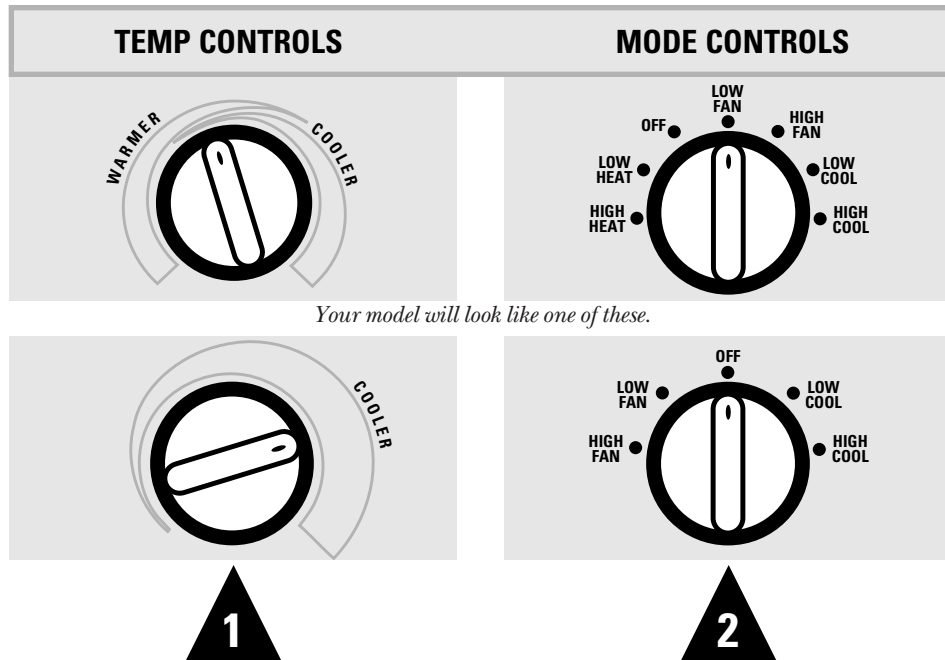

## 1 Temp Control

The temp control is used to maintain the room temperature. The compressor will cycle on and off to keep the room at the same level of comfort. When you turn the knob to **COOLER** (blue) the indoor air will become cooler. Turn the knob to **WARMER** (red) and the indoor air will become warmer.

### HEAT PUMP MODELS

When the outdoor temperature is lower than 25°F., heat is provided by the electric heater in the air conditioner instead of by the heat pump.

### NOTE:

The electric resistance heater in the 115-volt heat pump model operates during defrost when the outdoor coil temperature is below 36°F. It is not intended to provide full heat capability.

## 2 Mode Control

**HIGH COOL** and **LOW COOL** provide cooling with different fan speeds.

**HIGH HEAT** and **LOW HEAT** provide heating with different fan speeds.

**LOW FAN** or **HIGH FAN** provides air circulation and filtering without cooling or heating.

### NOTE:

**If you move the switch from a cool or heat setting to OFF or to a fan setting, wait at least 3 minutes before switching back to a cool or heat setting. A 3-minute delay is automatically provided on the Heat/Cool and Heat Pump models.**

# Cooling/Heating Descriptions



## FOR NORMAL COOLING OR HEATING

Select **HIGH COOL** or **HIGH HEAT** with the thermostat at mid point.

## FOR MAXIMUM COOLING

Select **HIGH COOL** with the thermostat at maximum cool.

## FOR MAXIMUM HEATING

Select **HIGH HEAT** with the thermostat at maximum heat.

## FOR QUIETER & NIGHTTIME COOLING

Select **LOW COOL** or **LOW HEAT** with the thermostat at mid point.

*Features and appearance may vary.*

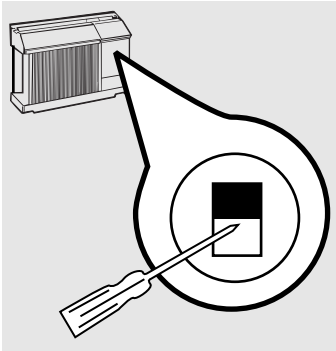

3

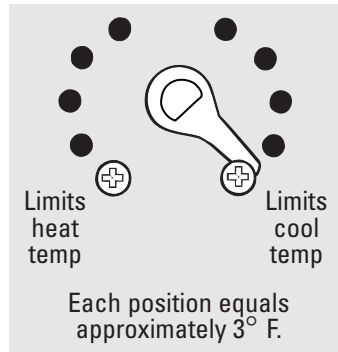

4

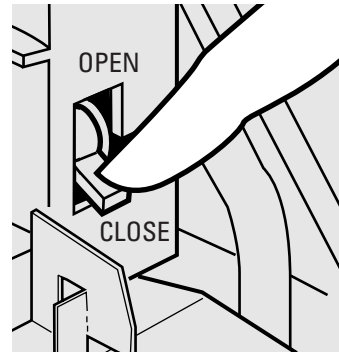

5

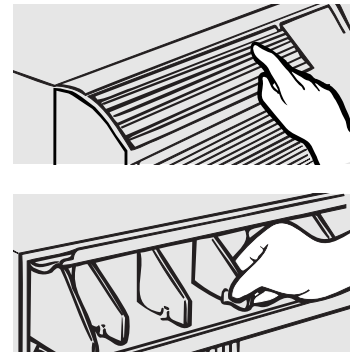

6

## 3 Fan Switch

On Heat/Cool models, the fan switch lever is located in a hole through the control panel. To reach it, you need to remove the front grille. Use a small screwdriver to change the setting. Cool only models have a rocker switch on the front of the control box.

When set at **CYCLE** (down) the fan cycles on and off when cooling or heating. When set at **CONT** (continuous, up) the fan runs all the time. The unit is shipped in the **CONT** setting.

## 4 Temperature Limiting

Limiting the maximum and minimum settings prevents users from turning the control to the extreme heat or cool positions.

The normal range of the temp control is approximately 60° F to 85° F. The control range may be narrowed by the use of the temperature limiting screws located behind the control panel.

## 5 Vent Control

The vent control is located behind the front grille. When set at **CLOSE**, only the air inside the room will be circulated and conditioned. You may adjust it by removing the front grille. When set at **OPEN**, some inside air is exhausted outside.

**NOTE:** The vent lever is taped in the **CLOSE** position when it leaves the factory. Remove the tape before using.

## 6 Air Direction

Horizontal louvers on the front grille let you control the air direction up and down.

Remove the front grille to adjust the vertical louvers side-to-side to direct the air left or right.



## ***Operating Instructions***

### *Care & Cleaning*

#### ***Grille and Case***

Turn the air conditioner off and remove the plug from the wall outlet before cleaning.

To clean, use water and a mild detergent. Do not use bleach or abrasives.

The coils on the outdoor side of the air conditioner should be checked regularly. It is necessary to remove the chassis from the wall case to inspect them. Dirt build-up occurs on the surface which is not visible from the outside. If they are clogged with dirt or soot they may be professionally steam cleaned, a service available through your GE service outlet.

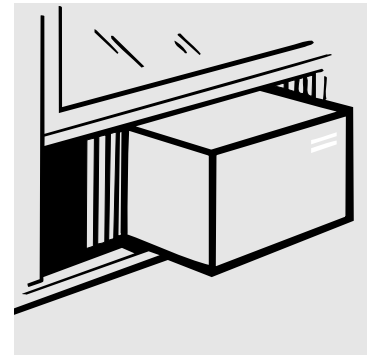

***Turn the air conditioner off before cleaning.***

The most important thing you can do to maintain the air conditioner is to clean the filter at least every 30 days. Clogged filters reduce cooling, heating and airflow.

***Keeping the filter clean will:***

- Decrease cost of operation.
- Save energy.
- Prevent clogged heat exchanger coils.
- Reduce the risk of premature component failure.

***To clean the air filter:***

- Vacuum off the heavy soil.
- Run water through the filter from the back side.
- Dry thoroughly before replacing.

Carefully pull the tab forward, up and out.

Replace the clean filter by pushing it back into place.

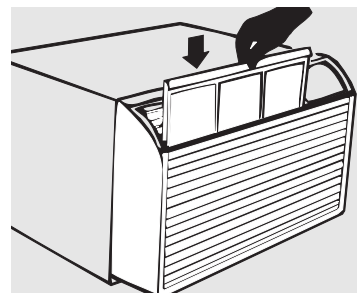

***⚠ CAUTION:***

***DO NOT operate the air conditioner without the filter in place. If a filter becomes torn or damaged it should be replaced immediately.***

Operating without the filter in place or with a damaged filter will allow dirt and dust to reach the indoor coil and reduce the cooling, heating, airflow and efficiency of the unit.

Replacement filters are available from your salesperson, GE dealer, GE Service and Parts Center or authorized Customer Care<sup>®</sup> servicers.



## Installation Instructions

### *Important Electrical Safety—Read Carefully*

**Installer:** Leave these instructions with the appliance.

**Owner:** Keep these instructions for future use.

#### Important Notes

- For personal safety, this air conditioner must be properly grounded.
- It is important to have the wall outlet and circuit checked by a qualified electrician if there is any doubt as to whether a proper ground exists.
- Follow National Electrical Code (NEC) or local codes and ordinances.

#### **⚠ CAUTION:**

- **Do not, under any circumstances, cut or remove the third (ground) prong from the power cord.**
- **Do not change the plug on the power cord of this air conditioner.**
- **Aluminum house wiring may present special problems—consult a qualified electrician.**

#### Electrical Requirements

We recommend that **the 230/208-volt, 60 Hz models** be installed on their own single branch circuit supplying 230/208-volt a.c., protected with a time delay fuse or circuit breaker.



**Parallel**  
115V.  
15 Amp.



**Perpendicular**  
230/208V.  
20 Amp.



**Tandem**  
230/208V.  
15Amp.

This is recommended for best performance and to prevent overloading house or apartment wiring circuits, which could cause a possible fire hazard from overheating wires.

**The 115-volt models** require a 115/120-volt a.c., 60 Hz grounded outlet protected with a 15-amp time delay fuse or circuit breaker.

The 3-prong grounding plug minimizes the possibility of electric shock hazard. If the wall outlet you plan to use is only a 2-prong outlet, it is your responsibility to have it replaced with a properly grounded 3-prong wall outlet.





# Before you begin

AJES and AJHS models have filler panels. Directions begin below. The installation instructions for AJCS models with accordion curtains begin on page 17.

**IMPORTANT:** Be sure to remove the shipping pad inside the air conditioner next to the compressor.

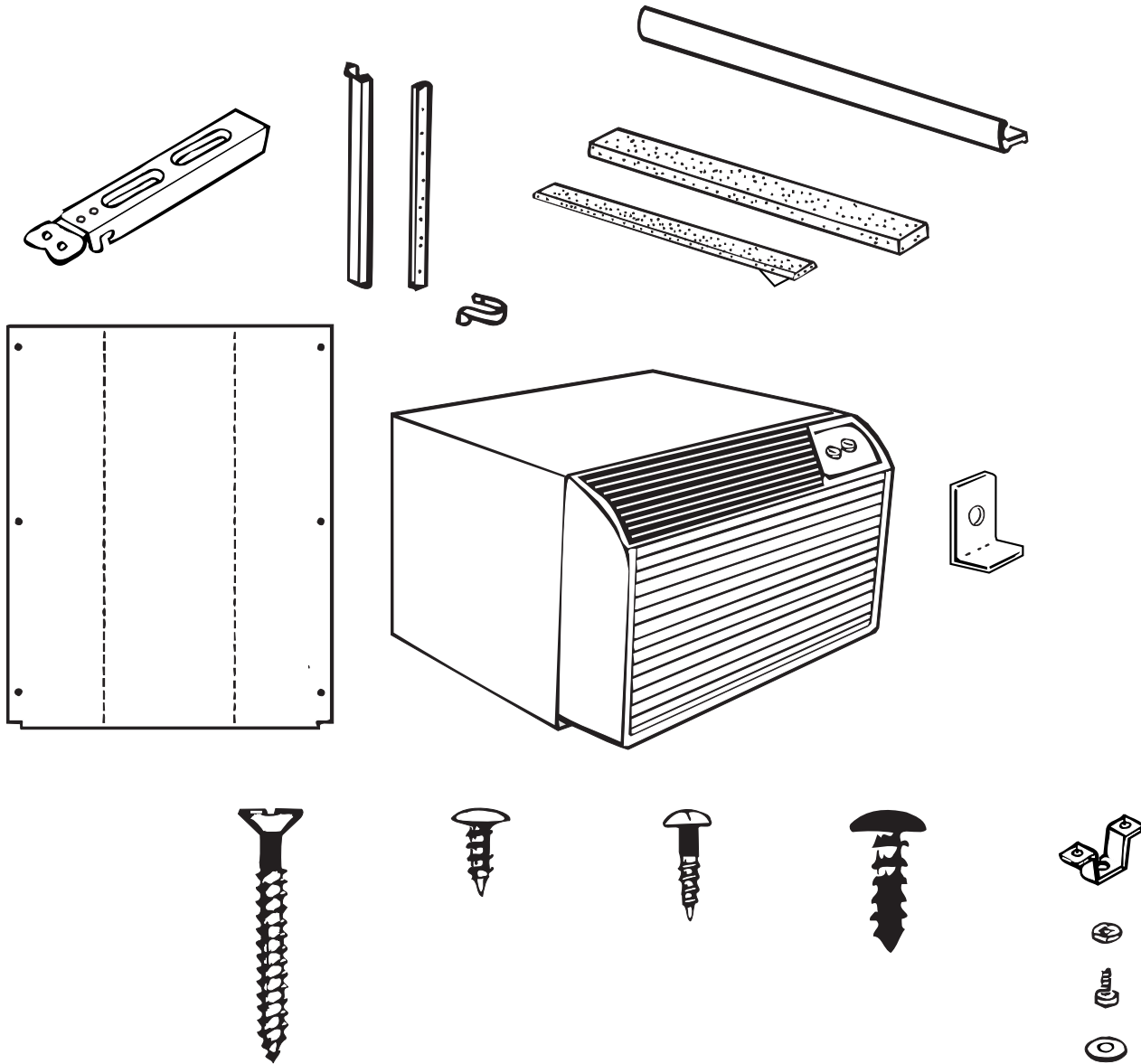

- Phillips-head screwdriver
- Wood saw

- Adjustable wrench
- Ruler or tape measure

- Scissors or knife
- Pencil

- Level
- Drill



# Installation Instructions

Read completely, then follow step-by-step

## 1

### Window Requirements

- These instructions are for a standard double-hung window. You will need to modify them for other types of windows.
- The air conditioner can be installed without the filler panels if needed to fit in a narrow window. See the window opening dimensions to the right.
- All supporting parts must be secured to firm wood, masonry or metal.
- The electrical outlet must be within reach of the power cord.

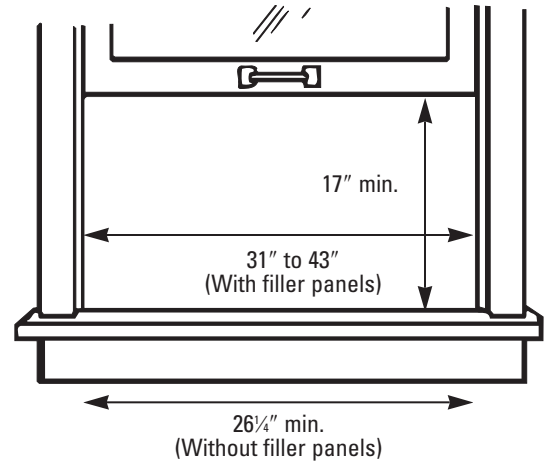

Window opening dimensions are for a standard double-hung window.

## 2

### Storm Window Requirements

A storm window frame will not allow the air conditioner to tilt towards the outside and will keep it from draining properly. To adjust for this, attach a piece of wood to the sill and the stool.

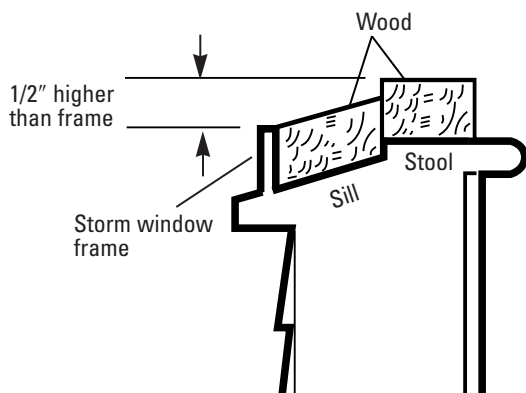

#### WOOD PIECES:

**WIDTH:** 2"

**LENGTH:** Long enough to fit inside the window frame.

**THICKNESS:** To determine the thickness, place a piece of wood on the stool to make it 1/2" higher than the top of the storm window frame.

Attach securely with nails or screws provided by the installer.



### 3 Remove the Air Conditioner From the Case

- 1 Remove the front grille. See the Care and Cleaning section.
- 2 Find the locking plate located on the front left side.
- 3 Remove the screw and the locking plate to unlock the air conditioner.

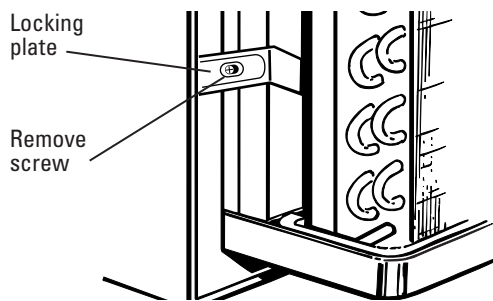

- 4 Remove and discard the shipping screw on the back of the air conditioner to allow removal of the air conditioner from the case.

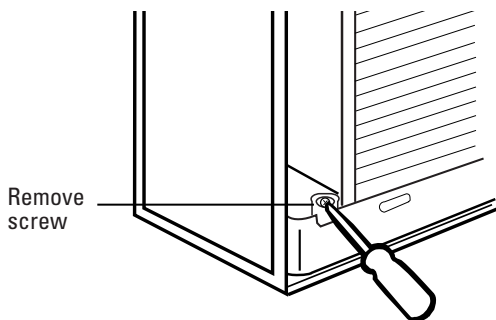

- 5 Pull the bottom corners of the air conditioner and slide it out of the case.
- 6 Remove the shipping pad inside the air conditioner next to the compressor.

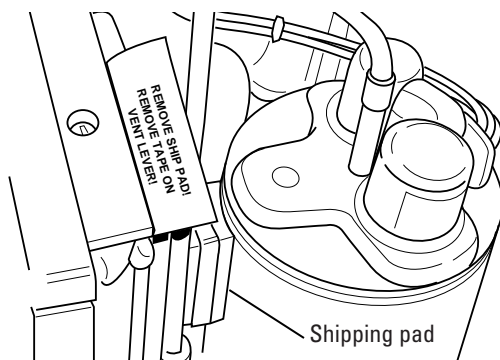

- 7 Remove the rear grille that is taped to the back of the case. Remove the packet of screws taped to the back of the grille. While holding the grille at a 45° angle, insert it into the clips at the top of the case and push the bottom in. Keep slight upward pressure on the grille until it fits flush with the bottom of the case.

If attaching the grille from the outside of the case use the 2 long screws.

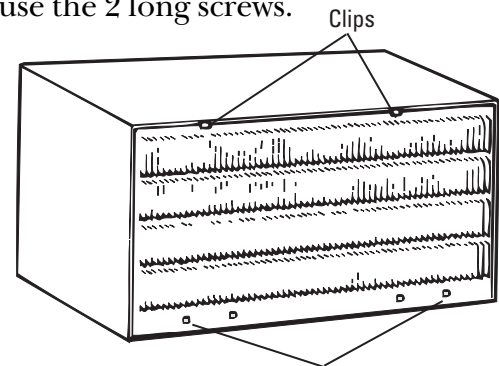

Insert the 2 long screws on the outside

If attaching the grille on the inside of the case use the 2 short screws.

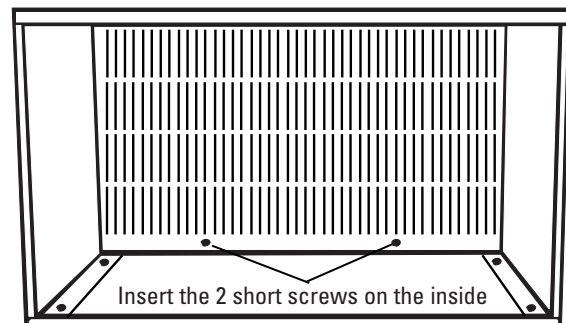



# Installation Instructions

## 4 Prepare the Window

1 Mark the centerline of the stool. Measure from the centerline  $13\frac{3}{8}$ " on both sides for the panel cuts.

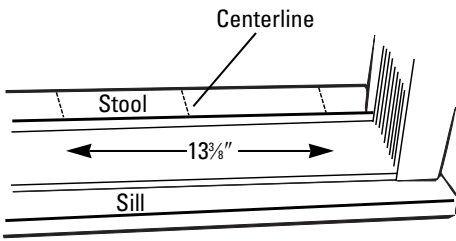

2 Measure  $12\frac{3}{8}$ " from the centerline on both sides for the sill support brackets.

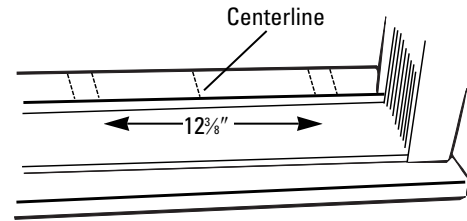

## 5 Install the Sill Supports

1 Assemble the sill supports. Do not fully tighten the spacer mounting screws at this time.

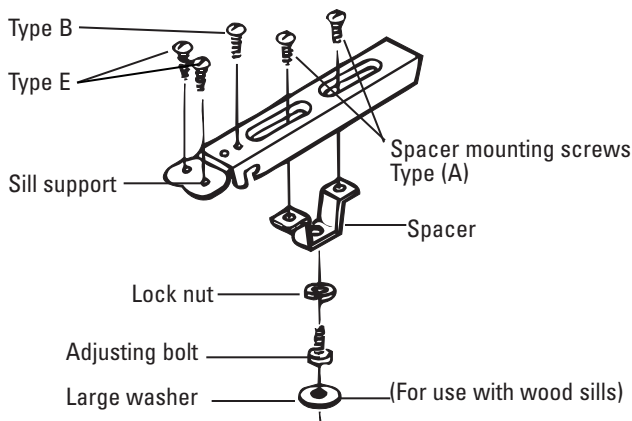

2 Before attaching the sill supports, place them on the window stool. Select the spacer position that will place the spacer near the outermost point on the sill. Tighten the spacer mounting screws.

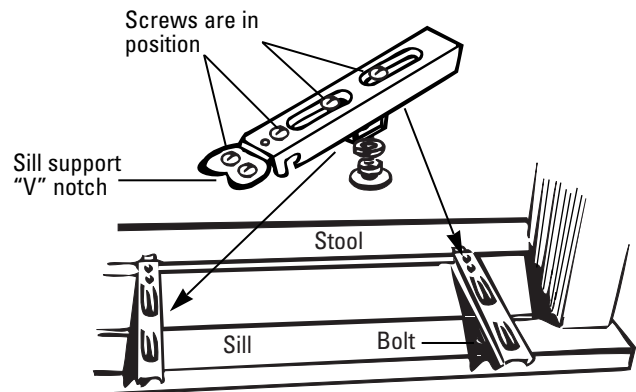

3 Turn the bolts and tighten the lock nuts to make the sill supports level or tilt down  $1/8$ " to the outside. Line up the "V" notch with  $12\frac{3}{8}$ " marks. Drill pilot holes and attach the sill supports.



**NOTES:**

- On narrow sills, there may not be enough room to use the lock nut.
- A deep offset sill may require a longer adjusting bolt than the standard hex head bolt provided.
- On wood sills use the large washer between the bolt head and the sill. This prevents the bolt from digging into the wood.



***Measure, Cut and Install the Filler Panels***



## 7 Install the Case in the Window

- 1 Peel off the backing from the bottom window gasket.
- 2 Place the gasket on the stool and over the brackets, even with the rear edge, sticky side down.

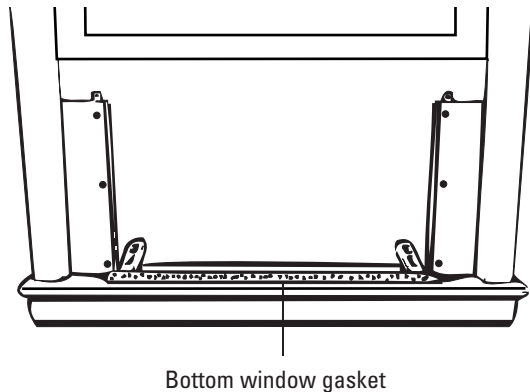

- 3 Carefully slide the empty case into the window until the holes in the case line up with the holes in the panel angles.

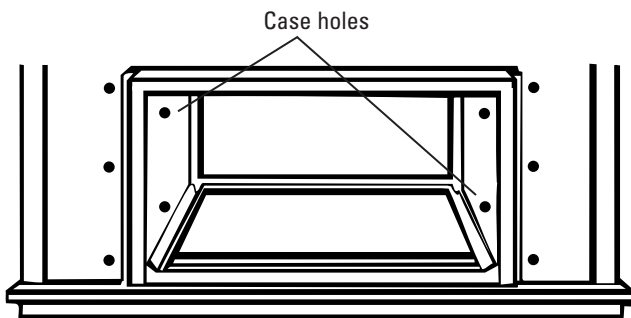

### NOTES:

- The case should have a 1/8" minimum tilt toward the outside.
- Be sure the seal gasket and panel gaskets remain in position and do not roll with the case.

- 4 Lower the window so it fits behind the panel tabs. Insert the 4 type A screws through the holes in the case and into the panel angles, 2 on each side.

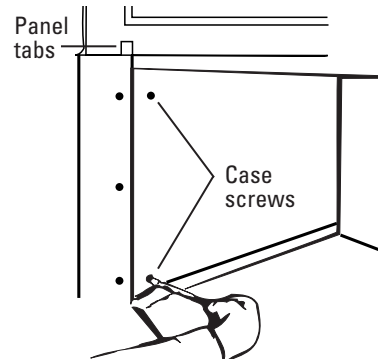

- 5 With the window closed, mark where the window sash meets the case.
- 6 Peel off the backing from the case top gasket.
- 7 Hold on to the case, open the window, and place the gasket along the mark on the case.

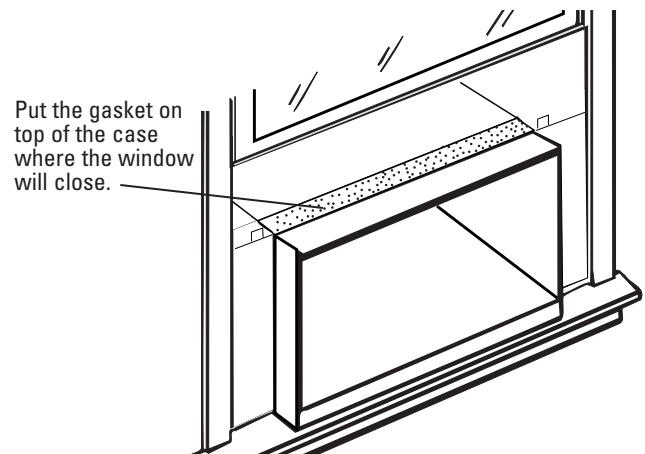



**7** Place the vinyl window gasket over the case top gasket. Insert the panel tabs through the slits in the gasket. Cut the gasket on each side to the width of the window.

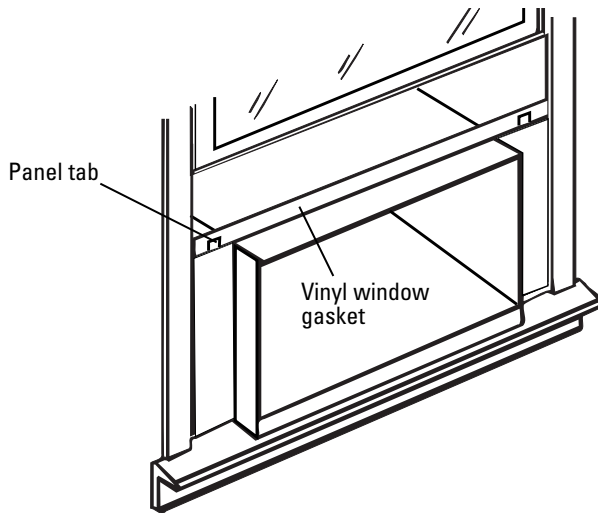

**8** Close the window tightly on the vinyl gasket. Bend the gasket forward to expose the panel tabs. Drill pilot holes into the window sash.

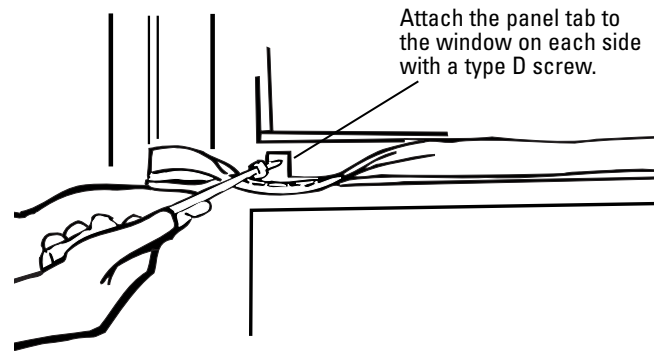

## 8

### *Install the Window Gasket and the Locking Bracket*

- 1** Cut the foam top window gasket to the window width.
- 2** Stuff the foam between the glass and the window to prevent air and insects from getting into the room.

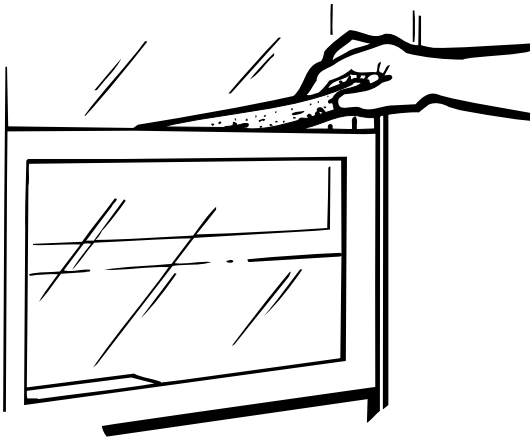

- 3** Attach the window locking bracket with 1 type E screw.

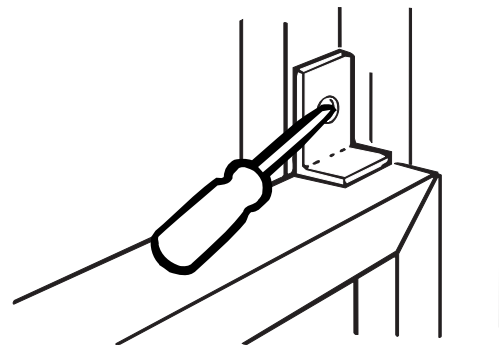



## ***Installation Instructions***

### ***Replace the Air Conditioner in the Case***

**1** Carefully slide the air conditioner back into the case.

**2** Attach the power cord to the base pan with the clamp.

**3** When the wall outlet is to the left, extend the cord under the unit and hold it in place with the clamp.

**4** Reinstall the locking plate with the tab behind the wall case flange. Tighten the screw.

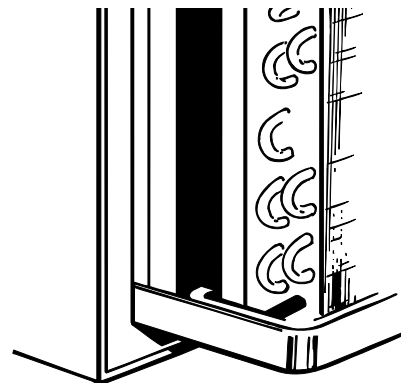

**5** Reattach the front grille. An opening for the power cord is on the bottom of the front grille.

**6** Fill holes and cracks with caulking provided by the installer.





# For models with accordion curtains

## Parts Included

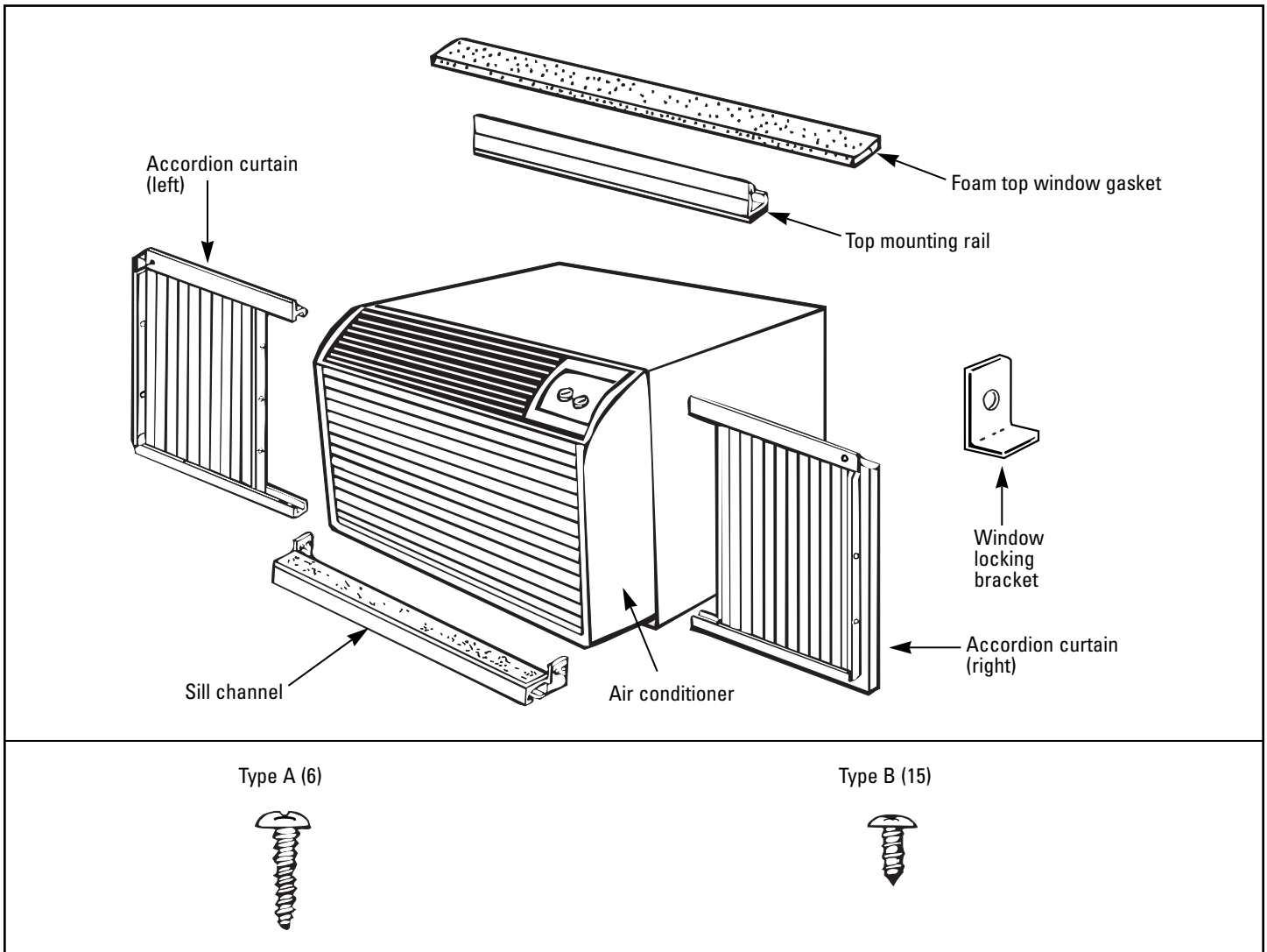

## Tools Needed

- Phillips-head screwdriver
- Ruler or tape measure
- Level
- Scissors or knife
- Pencil
- Drill



# Installation Instructions

Read carefully, then follow step-by-step

## 1

### Window Requirements

- These instructions are for a standard double-hung window. You will need to modify them for other types of windows.
- The air conditioner can be installed without the accordion curtains if needed to fit in a narrow window. See the window opening dimensions to the right.
- All supporting parts must be secured to firm wood, masonry or metal.
- The electrical outlet must be within reach of the power cord.

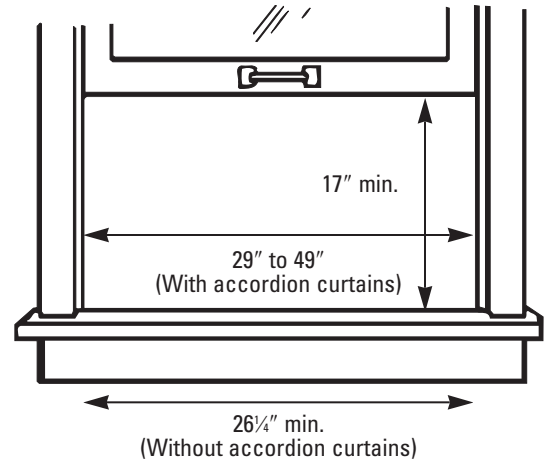

Window opening dimensions are for a standard double-hung window.

## 2

### Storm Window Requirements

A storm window frame will not allow the air conditioner to tilt towards the outside and will keep it from draining properly. To adjust for this, attach a piece of wood to the sill and the stool.

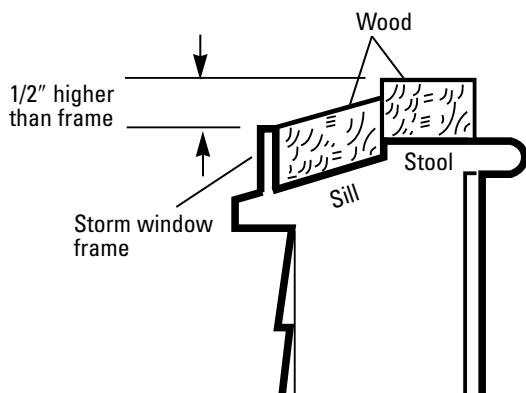

**WOOD PIECES:**

**WIDTH:** 2"

**LENGTH:** Long enough to fit inside the window frame.

**THICKNESS:** To determine the thickness, place a piece of wood on the stool to make it 1/2" higher than the top of the storm window frame.

Attach securely with nails or screws provided by the installer.



- 1** Remove the front grille. See the Care and Cleaning section.
- 2** Find the locking plate located on the front left side.
- 3** Remove the screw and the locking plate to unlock the air conditioner.

- 6** Remove the rear grille that is taped to the back of the case. Remove the packet of screws taped to the back of the grille. While holding the grille at a 45° angle, insert it into the clips at the top of the case and push the bottom in. Keep slight upward pressure on the grille until it fits flush with the bottom of the case.

If attaching the grille from the outside of the case use the 2 long screws.

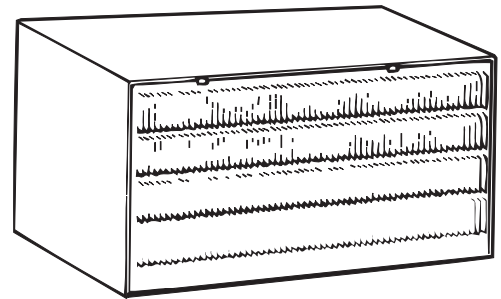

- 4** Remove and discard the shipping screw on the back of the air conditioner to allow removal of the air conditioner from the case.

If attaching the grille on the inside of the case use the 2 short screws.

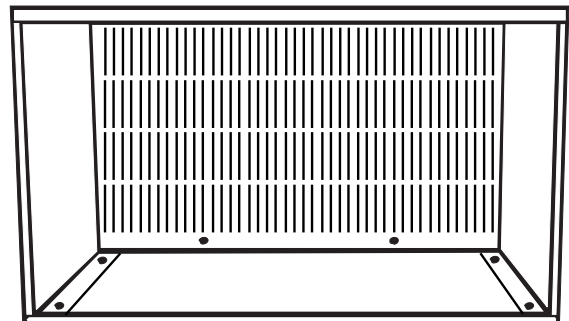

- 5** Pull the bottom corners of the air conditioner and slide it out of the case.



# Installation Instructions

*Read carefully, then follow step-by-step*

## 4 Prepare the Case

- 1 Install the top mounting rail with type B screws.
- 2 Attach the sill channel with type B screws. Align the holes on the bracket of the sill channel with the holes in the case.
- 3 Slide the right and left accordion curtains into the top mounting rail and sill channel. Secure with type B screws.

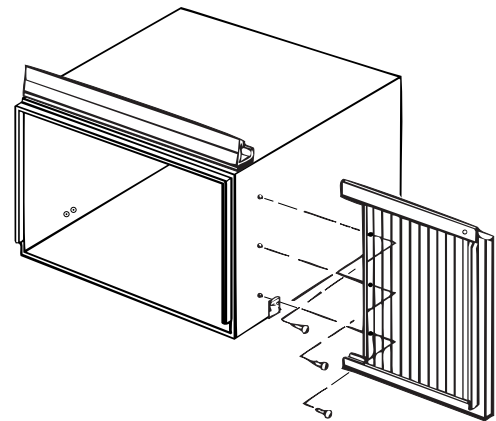
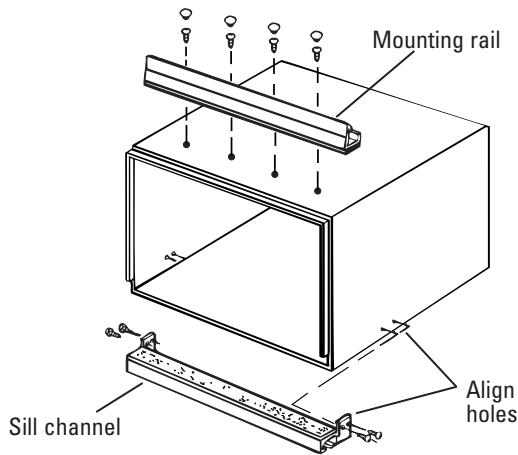

## 5 Install the Case in the Window

- 1 Open the window and center the case in the window. Lower the window behind the top mounting rail. This should provide a 1/8" tilt toward the outside.
- 2 Extend curtains and drill pilot holes in the side of the window and the window sash. Attach the curtains with 3 screws on each side.

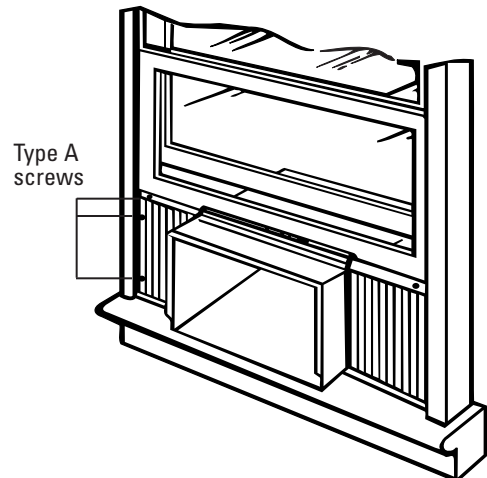
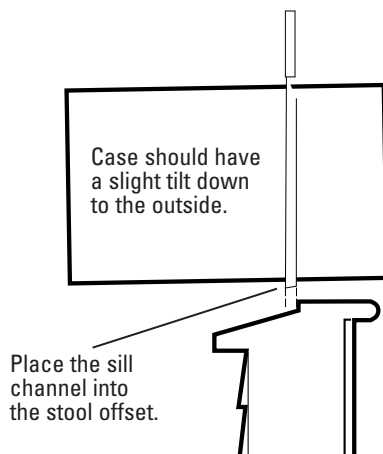



## **6** *Install the Window Gasket and the Locking Bracket*

**1** Cut the foam top window gasket to the window width.

**2**



## Installation Instructions

- 3** When the wall outlet is to the left, extend the cord under the unit and hold it in place with the clamp.

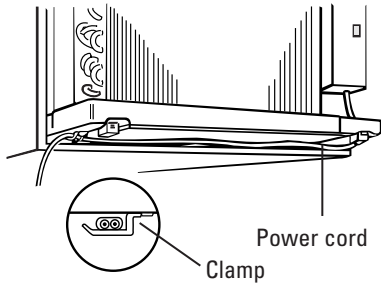

- 4** Reinstall the locking plate with the tab behind the wall case flange. Tighten the screw.

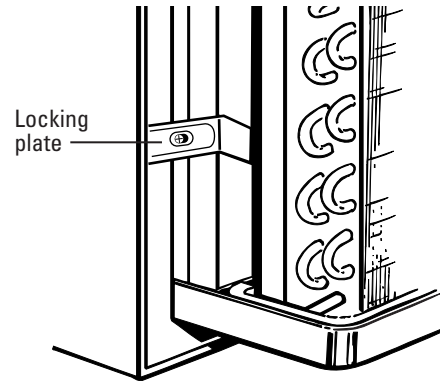

- 5** Reattach the front grille. An opening for the power cord is on the bottom of the front grille.
- 6** Fill holes and cracks with caulking provided by the installer.



# Through-the-Wall Installation

## 1

### Preparation of the Opening in the Wall

Make certain a wall receptacle is available close to the hole location or make arrangements to install a receptacle.

The cord length for the 115-volt models is 72" to the right and 47" to the left. For the 230/208-volt models the cord length is 65" to the right and 39" to the left.

## 2

### Support Requirements for the Air Conditioner

The air conditioner wall case may be installed flush with the inside wall or flush with the outside wall.

The finished sides of the opening should be structural wall members.

**Lintel**—Use a lintel in brick veneer and brick and block types of wall to support the bricks or blocks above the opening. Do not allow the wall case to be used in lieu of a lintel.

**Flashing**—Install flashing (drip rail) as shown to prevent water from dripping inside the wall and down the outside of the building.

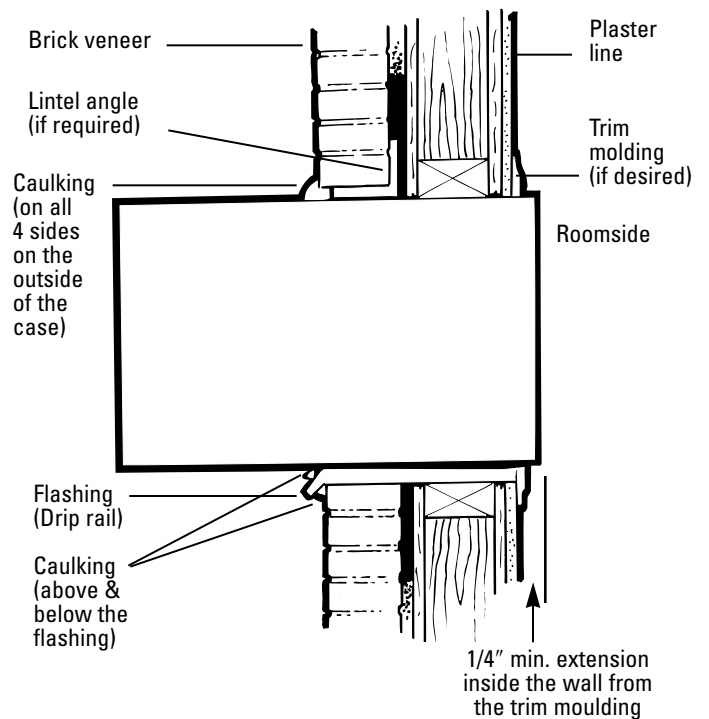

## 3

### Mortar and Caulking



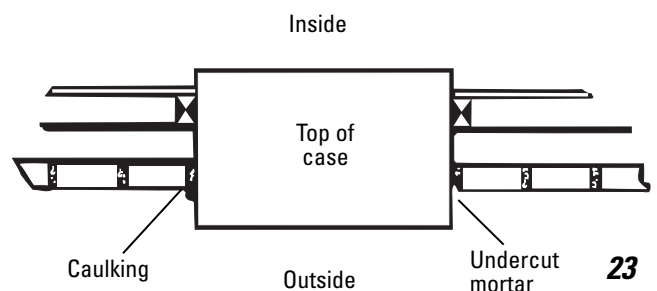

Mortar between the case and the brick all around the case may be undercut at about 45° for improved caulking.





## *Helpful Information*

### *Things That Are Normal*

<i>Noise</i>	<i>Explanation</i>
<b>PING!</b> 	You may hear a pinging noise caused by water being picked up and thrown against the condenser on rainy days or when the humidity is high. This design feature helps remove moisture and improve efficiency.
<b>"CLICK"</b> 	You may hear the thermostat click when the compressor cycles on and off.
<b>DRIP</b> 	Water will collect in the base pan during high humidity or on rainy days. The water may overflow and drip from the outdoor side of the unit.
<b>WHIR!</b> 	The fan may run even when the compressor is not.



## If Something Goes Wrong

### Before You Call for Service



<b>Problem</b>	<b>Possible Causes</b>	<b>What to Do</b>
<b>Air Conditioner Doesn't Start</b>	The air conditioner is unplugged	<ul style="list-style-type: none"><li>• Make sure the air conditioner plug is pushed completely into the outlet.</li></ul>
	The fuse is blown/circuit breaker is tripped	<ul style="list-style-type: none"><li>• Check the house fuse/circuit breaker box and replace fuse or reset the breaker.</li></ul>
	Power failure	<ul style="list-style-type: none"><li>• If power failure occurs, turn the mode control to <b>OFF</b>. When power is restored, wait 3 minutes to restart the air conditioner to prevent tripping of the compressor overload.</li><li>• There is a protective time delay (up to 3 minutes) in the heat/cool and heat pump models. Wait 3 minutes for the air conditioner to resume heating or cooling.</li></ul>
<b>Air Conditioner Does Not Cool or Heat as it Should</b>	Airflow is restricted	<ul style="list-style-type: none"><li>• Make sure there are no curtains, blinds or furniture blocking the front of the air conditioner.</li></ul>
	The temperature control may not be set high or low enough	<ul style="list-style-type: none"><li>• Turn the knob to a warmer or cooler setting. The coolest setting provides maximum cooling. The warmest setting provides maximum heating on models with heat.</li></ul>
	The air filter is dirty	<ul style="list-style-type: none"><li>• Clean the filter at least every 30 days. See the Care and Cleaning section.</li></ul>
	The room may have been hot or cold	<ul style="list-style-type: none"><li>• When the air conditioner is first turned on you need to allow time for the room to cool down or warm up.</li></ul>
	Cold air is escaping	<ul style="list-style-type: none"><li>• Check for open furnace floor registers and cold air returns.</li><li>• Set the exhaust vent in the closed position.</li></ul>
	Cooling coils have iced up	<ul style="list-style-type: none"><li>• See freezing up below.</li></ul>
<b>Air Conditioner Freezing Up</b>	Ice blocks the airflow and stops the air conditioner from cooling the room	<ul style="list-style-type: none"><li>• Set the mode control at <b>HIGH FAN</b> or <b>HIGH COOL</b> with the temperature at a warmer setting.</li></ul>

---

## *Notes*

---

---

---

---

---

---

---

---

---

---

---

---

---

---

---

---

---

---

---

---

---

---

---

---

---

---

---

---

---

---





## GE Service Protection Plus™

GE, a name recognized worldwide for quality and dependability, offers you Service Protection Plus™—comprehensive protection on all your appliances—**No Matter What Brand!**

**Benefits Include:**

- Backed by GE
- All brands covered
- Unlimited service calls
- All parts and labor costs included
- No out-of-pocket expenses
- No hidden deductibles
- One 800 number to call

***We'll Cover Any Appliance.  
Anywhere. Anytime.\****

You will be completely satisfied with our service protection or you may request your money back on the remaining value of your contract. No questions asked. It's that simple.

Protect your refrigerator, dishwasher, washer and dryer, range, TV, VCR and much more—**any brand!** Plus there's no extra charge for emergency service and low monthly financing is available. Even icemaker coverage and food spoilage protection is offered. You can rest easy knowing that all your valuable household products are protected against expensive repairs.

Place your confidence in GE and call us in the U.S. toll-free at **800-626-2224** for more information.

\*All brands covered, up to 20 years old, in the continental U.S.

 Cut here

Please place in envelope and mail to:

***General Electric Company***  
**Warranty Registration Department**  
**P.O. Box 34070**  
**Louisville, KY 40232-4070**

# Consumer Product Ownership Registration

Dear Customer:

Thank you for purchasing our product and thank you for placing your confidence in us. We are proud to have you as a customer!

## Follow these three steps to protect your new appliance investment:

**1** Complete and mail your Consumer Product Ownership Registration today. Have the peace of mind of knowing we can contact you in the unlikely event of a safety modification.

**2** After mailing the registration below, store this document in a safe place. It contains information you will need should you require service. Our service number is 800-GE-CARES (800-452-2737).

**3** Read your Owner's Manual carefully. It will help you operate your new appliance properly. If you have questions, or need more information call the GE Answer Center® 800.626.2000.

Model Number

Serial Number

--	--

**Important: If you did not get a registration card with your product, detach and return the form below to ensure that your product is registered.**

 Cut here

# Consumer Product Ownership Registration



Model Number

Serial Number

--	--

Mr.  Ms.  Mrs.  Miss

First Name

Last Name

Street Address

Apt. #

City

State  Zip Code

Date Placed In Use  
 Month  Day  Year

Phone Number  -  -



GE Appliances

**HOTPOINT**

**RCA**

# GE Service Numbers

*We'll be there!*



## GE Answer Center®

**800.626.2000**

**TDD  
800-833-4322**

Open 24 hours a day,  
7 days a week.

## In-Home Repair Service

**800-GE-CARES  
(800-432-2737)**

We provide expert repair service,  
scheduled at a time that's  
convenient for you.

Our factory-trained technicians  
know your appliance inside and out—  
so most repairs can be handled in  
just one visit.

## Service Contracts

**800-626-2224**

With a service contract GE  
Consumer Service will still be there  
after your warranty expires.

With a multiple-year contract,  
you're assured of future service at  
today's prices.

## Parts and Accessories

**800-626-2002**

Individuals qualified to service  
their own appliances can have  
parts or accessories sent directly  
to their home.

VISA, MasterCard and Discover  
cards are accepted.

**Care and cleaning instructions con-  
tained in this manual cover proce-  
dures to be performed by any user.  
Other servicing generally should be  
referred to qualified service per-  
sonnel. Caution must be exercised,  
since improper servicing may cause  
unsafe operation.**

## Further Service

If for some reason you  
are not happy with the  
service you receive, here  
are three steps to follow  
for further help.

**First**, contact the people who ser-  
viced your appliance. Explain why  
you are not pleased.

**Next**, if you are still not pleased,  
write all the details—including  
your phone number—to:

Consumer Relations  
GE Appliances  
Louisville, KY 40225

**Finally**, if your problem is still  
not resolved, write:

Major Appliance  
Consumer Action Program  
20 North Wacker Drive  
Chicago, IL 60606

# AIR CONDITIONER WARRANTY

*Staple sales slip or cancelled check here. Proof of original purchase date is needed to obtain service under warranty.  
For service, call 800-GE-CARES.*

## What Is Covered

### FULL ONE-YEAR WARRANTY

For one year from date of original purchase, we will provide, free of charge, parts and service labor in your home to repair or replace *any part of the room air conditioner* that fails because of a manufacturing defect.

### FULL FIVE-YEAR WARRANTY

For five years from the date of original purchase, we will provide, free of charge, parts and service labor in your home to repair or replace *any part of the sealed refrigerating system* (the compressor, condenser, evaporator and all connecting tubing) that fails because of a manufacturing defect.

## What Is Not Covered

- Service trips to your home to teach you how to use the product.
- Improper installation.  
If you have an installation problem, or if the air conditioner is of improper cooling capacity for the intended use, contact your dealer or installer. You are responsible for providing adequate electrical connecting facilities.
- Replacement of house fuses or resetting of circuit breakers.
- In commercial locations labor necessary to move the unit to a location where it is accessible for service by an individual technician.
- Failure of the product resulting from modifications to the product or due to unreasonable use including failure to provide reasonable and necessary maintenance.
- Failure due to corrosion on models not corrosion-protected.
- Damage to product caused by improper power supply voltage, accident, fire, floods or acts of God.
- Incidental or consequential damage to personal property caused by possible

This warranty is extended to the original purchaser and any succeeding owner for products purchased for home use within the USA. In Alaska, the warranty excludes the cost of shipping or service calls to your home.

Some states do not allow the exclusion or limitation of incidental or consequential damages. This warranty gives you specific legal rights, and you may also have other rights which vary from state to state. To know what your legal rights are in your state, consult your local or state consumer affairs office or your state's Attorney General.