

Air-Cooled Condensing Units

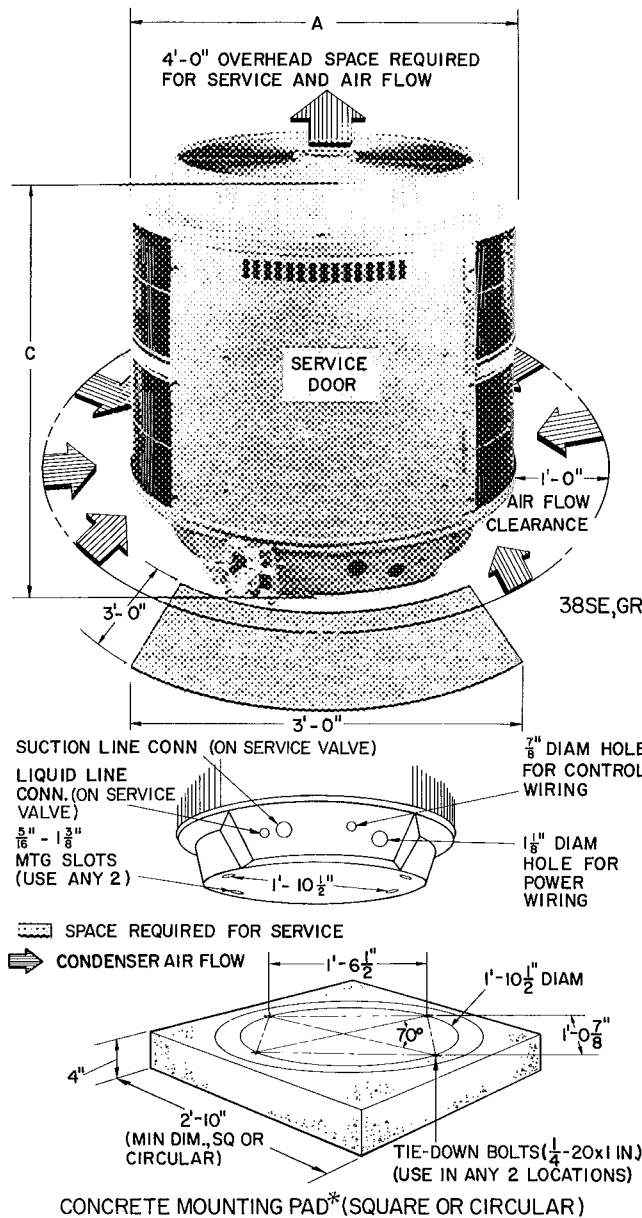

CONCRETE MOUNTING PAD*(SQUARE OR CIRCULAR)

*CONCRETE PAD SHOULD WEIGH 1 1/2 TO 2 TIMES WEIGHT OF UNIT

Fig. 1 — Dimensions, Connections and Mounting Pad

TRANSPORTATION DAMAGE

File claim with shipping company if shipment is damaged or incomplete.

PRELIMINARY SURVEY

Consult local building codes and National Electrical Code (NEC) for special installation requirements.

When installing unit, allow sufficient space for airflow clearance, wiring, refrigerant piping and servicing unit. Recommended minimum requirement is 3 ft (Fig. 1). Position unit so water from roof or eaves will not pour directly on top of unit.

Install unit on a solid, level mounting pad. Position tie-down bolts in pad. Any 2 holes in unit base may be used to fasten unit to pad.

38GR Condensing Units Connected to Carrier-Approved Evaporators with Carrier Accessory Tubing — 38GR units contain correct refrigerant charge when evaporator is same size, or one size larger than condensing unit and are connected with Carrier accessory tubing. Check refrigerant charge when tubing lengths are above 50 feet. See Refrigerant Charging for details.

38SE Condensing Units Connected to Carrier-Approved Evaporators — 38SE units contain correct system refrigerant charge when evaporator is same size as condensing unit, and they are connected with 25 ft or less of field-supplied tubing of recommended size (see Piping Connections) or 50 ft or less of Carrier accessory tubing. Check refrigerant charge for maximum system efficiency. See Refrigerant Charging for details.

38GR,SE Condensing Units Connected to Non-Carrier Evaporators — Check refrigerant charge when the 38GR,SE is added to a system in which other than a Carrier approved evaporator is being used or where the evaporator has been previously installed. Field-supplied refrigerant piping must be in accordance with Refrigerant Piping Data table.

Use an evaporator coil with a bleed-type expansion device. If coil does not have a bleed-type expansion device it may be necessary to add an accessory start capacitor and relay to condensing unit. This would require removing compressor start thermistor (PTC device) on units so equipped.

PIPING CONNECTIONS

The 38GR,SE condensing units can be connected to evaporator sections using Carrier accessory tubing package or field-supplied tubing of refrigerant grade (Accessory

Table 1 — Installation Data

CONDENSING UNIT	38GR						38SE					
	002	003	004	045	005	006	002	003	004	045	055	
OPERATING WT (lb)	151	170	182	194	234	260	176	180	192	248	255	
DIMENSIONS (ft-in.)	Diam A						2-5 1/4					
	Height B						2-4	2-4	2-4	2-4	2-8	3-8
REFRIG CONN.	Suct ODF						5/8	3/4	3/4	3/4*	3/4*	3/4*
	Liq ODF						3/8					

*38GR005,006 and 38SE004,045,055 supplied with 3/4-in to 1 1/8-in suction valve connection adapter (field installed) for 1 1/8-in suction line (field supplied)

tubing not available for 38GR006.) See Table 2 for accessory tubing sizes and Table 3 for recommended field-supplied tubing sizes. (Where evaporator is 20 ft or more below condensing unit, reduce liquid line size one diameter – min 1/4-in. OD.)

A capacity reduction results if accessory tubing is used in 38SE004,045,055 systems. For example, when a 25 ft accessory tubing package is used, there is a capacity reduction of 2 1/2% on 38SE004, 3 3/4% on 38SE045 and 5% on 38SE055 systems. For maximum capacity from these systems, use tubing sizes shown in Table 3.

Connection Recommendations – Do not use damaged or contaminated tubing. Do not use less than 10 ft of liquid line. Do not cut 5/16-in or 1/4-in. liquid line. Bend or coil to fit.

If accessory tubing package or evaporator section has been open for more than 15 seconds per connection, evacuate or purge evaporator coil and tubing system (use field-supplied refrigerant, not unit refrigerant) Always evacuate or purge if field-supplied tubing is used.

When making piping connections, be sure to provide clearance at unit for electrical connections.

Connect refrigerant liquid and suction lines to condensing unit (Fig 1). Unit compatible fittings permit mechanical (quick-connect) or sweat connections.

38GR005,006; 38SE004,045,055 Units – When using 1 1/8-in. field-supplied suction line, remove suction line adapter taped to compressor suction line. Connect 3/4-in. end of adapter to unit suction line compatible fitting. Sweat connect refrigerant suction line to 1 1/8-in. end of adapter. Connect liquid refrigerant line to unit. When a 7/8-in. field-supplied suction line is used on 38SE003 or 38GR045, a field-supplied 3/4-in. to 7/8-in. suction line adapter must be provided.

MECHANICAL CONNECTION (Mate one set of connections at a time.)

1. Loosen nut on compatible fitting one turn. Do not remove.
2. Remove plug and be sure O-ring is in the groove inside the compatible fitting.
3. Cut tubing to correct length.
4. Use gage on tag attached to service valve to mark tube end for correct insertion depth. Insert tube into compatible fitting until it bottoms. (Tube should be inserted at least as far as mark on tubing.)
5. Tighten nut until it *bottoms* on back coupling flange

SWEAT CONNECTION (Use refrigerant grade tubing.)

1. Remove locking nut, rubber O-ring and Schrader core from valve.
2. Cut tubing to correct length.

Table 2 – Accessories

PART NO.	DESCRIPTION							
HH01AD040 HH93AZ040 HH51AR001	Low-Voltage Control – Honeywell Deluxe Thermostat Thermostat Subbase Comfort Control Center (Use with HH01AD040.)							
HH07AT070, HH07AT074 HH93AZ076	Low-Voltage Control – Honeywell Thermostat Thermostat Subbase (with Automatic Changeover)							
HH01AD042 HH93AZ042	Low-Voltage Control – Honeywell Thermostat Thermostat Subbase							
HH01YA092 HH93YZ094	Low-Voltage Control – Grayson Thermostat Thermostat Subbase							
32LT900301	Solid State Head Pressure Control. Special field-installed fan and/or motor required.							
	UNIT	38SE002,003			38SE004			
	Motor No. Fan No.	HC38VE851 LA01AA020			HC40VL701 LA01AA023			
	UNIT	38GR002,003,004,045			38GR005,006			
	Motor No.	HC38VE851			HC40VL701			
38GC900-152	Indoor Fan Relay (Six – 38BA400693)							
38GB900021	Thermal Expansion Valve (Six – EA61DC100)							
	TUBING PACKAGES						UNIT	
	Length (ft)	Liquid		Suction*				
		OD (in.)	Tube End OD (in.)	OD (in.)	Tube End OD (in.)			
					Evap			Cond
38GC900031 38GC900041 38GS900221 38GC900061 38GC900191	10 18 25 35 50	3/8 3/8 3/8 5/16 1/4	3/8 3/8 3/8 3/8 3/8	5/8 5/8 5/8 5/8 5/8	3/4† 3/4† 3/4† 3/4† 3/4†	5/8 5/8 5/8 5/8 5/8	38SE002, 38GR002	
38GC900071 38GC900081 38GC900091 38GC900101 38GC900111	10 18 25 35 50	3/8 3/8 3/8 3/8 3/8	3/8 3/8 3/8 3/8 3/8	3/4 3/4 3/4 3/4 3/4	3/4 3/4 3/4 3/4 3/4	3/4 3/4 3/4 3/4 3/4	38SE003,004,045,055 38GR003,004,045,005	

*Suction line is insulated and has a 90° bend at one end

†For 5/8-in evaporator connection, cut off 3/4-in. end.

NOTE: Do not cut 3/8-in OD liquid line to a length shorter than 10 feet Do not cut 5/16- or 1/4-in liquid line.

Table 3 – Field-Supplied Piping Data

COND UNIT	REFRIG CONTROL	MAX COND UNIT HT (ft)		REFRIGERANT LINE LENGTH (ft)									
				25-50		51-75		76-100		101-125		126-150	
		Above Evap	Below Evap	Line Diameter (in. OD)									
				Suct	Liq	Suct	Liq	Suct	Liq	Suct	Liq	Suct	Liq
38GR002	TXV	90	90										
	Cap. Tube or AccuRater™	150	50	3/4	3/8	3/4	3/8	3/4	3/8	3/4	3/8	3/4	3/8
38GR003	TXV	90	90										
	Cap. Tube or AccuRater	150	50	3/4	3/8	3/4	3/8	3/4	3/8	3/4	3/8	7/8	3/8
38GR004	TXV	90	90										
	Cap. Tube or AccuRater	150	50	3/4	3/8	3/4	3/8	7/8	3/8	7/8	1/2	7/8	1/2
38GR045	TXV	90	90										
	Cap. Tube or AccuRater	150	50	7/8	3/8	7/8	1/2	7/8	1/2	7/8	1/2	7/8	1/2
38GR005	TXV	90	90										
	Cap. Tube or AccuRater	150	50	1 1/8	3/8	1 1/8	1/2	1 1/8	1/2	1 1/8	1/2	1 1/8	5/8
38GR006	TXV	90	90										
	Cap. Tube or AccuRater	150	50	1 1/8	3/8	1 1/8	5/8	1 1/8	5/8	1 1/8	5/8	1 1/8	5/8
38SE002	TXV	90	90										
	Cap. Tube or AccuRater	150	50	3/4	3/8	3/4	3/8	7/8	3/8	7/8	3/8	7/8	3/8
38SE003	TXV	90	90										
	Cap. Tube or AccuRater	150	50	7/8	3/8	7/8	3/8	7/8	3/8	7/8	3/8	7/8	3/8
38SE004	TXV	90	90										
	Cap. Tube or AccuRater	150	50	1 1/8	3/8	1 1/8	3/8	1 1/8	3/8	1 1/8	3/8	1 1/8	3/8
38SE045	TXV	90	90										
	Cap. Tube or AccuRater	150	50	1 1/8	3/8	1 1/8	1/2	1 1/8	1/2	1 1/8	1/2	1 1/8	1/2
38SE055	TXV	90	90										
	Cap. Tube or AccuRater	150	50	1 1/8	3/8	1 1/8	1/2	1 1/8	1/2	1 1/8	1/2	1 1/8	5/8

Cap. Tube – Capillary Tube
 TXV – Thermal Expansion Valve

NOTES:
 1 Systems with over 50 ft separation between condensing unit and evaporator require refrigerant charge adjustment to ensure the proper superheat at compressor. See Refrigerant Charging, page 5. Oil charge adjustment may also be required.
 2 Reduce liquid line diameter by 1/8-in. OD (minimum 1/4-in. OD) when evaporator is 20 ft or more below condensing unit.

3. Insert tube into compatible fitting. Wrap top and bottom of service valves in wet cloth to prevent damage by heat. Solder with low-temperature (450 F) silver alloy solder.
4. Replace Schrader core.
5. Evacuate or purge system with field-supplied refrigerant.

SERVICE DOOR

Service door can be opened or removed for wiring or servicing unit

Remove 3 screws from left side of service door (Fig. 1) to swing door open.

Door Removal – Turn power off. Disconnect wiring from

control panel mounted on door. Refer to Fig. 7 and 8. After wiring is disconnected, lift door from roll pin hinges.

ELECTRICAL DATA AND WIRING

Field wiring must comply with local and national fire, safety and electrical codes. Voltage to unit must be within ± 10% of voltage indicated on nameplate. On 3-phase units, phases must be balanced within 2%. Contact local power company for correction of improper line voltage.

Operation of unit on improper line voltage constitutes abuse and is not covered by Carrier Warranty.

See Table 4 for recommended wire and fuse sizes. When making electric connections, provide clearance at unit for refrigerant piping connections.

Table 4 – Electrical Data

COND UNIT	V/PH	OPER VOLTS*		COMPR		FAN	BRANCH CIRCUIT				
				LRA	FLA	FLA	Wire Size† (AWG)		Max F†† Wire	Fuse Amp‡	
		Max	Min								
38GR002---	230/1	253	207	72.0	14.8	1.0	12	10	32.0	50.0	30
38GR002310				72.0	14.8	1.0	12	10	32.0	50.0	30
38GR003---				90.0	19.2	1.1	10	8	39.0	62.0	40
38GR003310				90.0	19.2	1.1	10	8	39.0	62.0	40
38GR004---				100.0	22.9	1.3	10	6	33.0	51.0	50
38GR004310				100.0	22.9	1.3	10	6	33.0	51.0	50
38GR045---				94.0	23.9	1.3	8	6	49.0	76.0	50
38GR005---				106.0	27.9	2.0	8	6	42.0	64.0	60
38GR006---	135.0	39.0	2.0	6	4	47.0	72.0	80			
38GR003---	200/3	220	180	60.0	13.0	1.1	12	10	42.0	67.0	30
38GR003410				70.0	13.0	1.1	12	10	42.0	67.0	30
38GR004---				69.0	14.0	1.3	12	10	39.0	63.0	30
38GR004410				80.0	14.0	1.3	12	10	39.0	63.0	30
38GR045---				79.0	16.7	1.3	12	10	33.0	52.0	35
38GR005---				87.0	18.3	2.0	10	8	46.0	82.0	40
38GR006---				113.0	24.0	2.0	8	6	64.0	85.0	50
38GR003---				230/3	253	207	50.0	11.5	1.1	12	10
38GR003510	60.0	11.5	1.1				12	10	52.0	82.0	25
38GR004---	60.0	12.6	1.3				12	10	47.0	75.0	25
38GR004510	70.0	12.6	1.3				12	10	47.0	75.0	25
38GR045---	67.0	14.3	1.3				12	10	42.0	66.0	30
38GR005---	70.0	16.4	2.0				10	8	56.0	100.0	35
38GR006---	98.0	19.9	2.0				10	8	47.0	84.0	45
38GR004---	460/3	506	414				30.0	6.5	5	14	12
38GR004610				35.0	6.5	5	14	12	110.0	160.0	15
38GR045---				35.0	7.2	.5	14	12	100.0	140.0	15
38GR005---				35.0	8.8	1.3	14	12	81.0	131.0	20
38GR006---				49.0	10.4	1.3	14	12	70.0	112.0	20
38SE002---				230/1	253	207	65.0	10.3	.8	14	12
38SE003---	72.0	14.8	.8				12	10	32.0	51.0	30
38SE004---	90.0	19.2	.8				10	8	40.0	62.0	40
38SE045---	94.0	23.9	1.3				10	8	32.0	50.0	50
38SE055---	106.0	28.0	2.2				10	8	27.0	43.0	60

Corresponding wire sizes and wire lengths

FLA – Full Load Amps

LRA – Locked Rotor Amps

--- Electrical data shown applicable to all units for which complete model numbers are not shown. Example: 38GR003--- applies to all 003 models except 38GR003510.

*Permissible limits of the voltage range at which the unit will operate satisfactorily

†Copper wire sizes and lengths. Use latest National Electrical Code (NEC) for aluminum wire sizing

‡Maximum dual element fuse size

NOTE: Control circuit voltage is 24 volts on all units. On 3-phase units, phases must be balanced within 2%

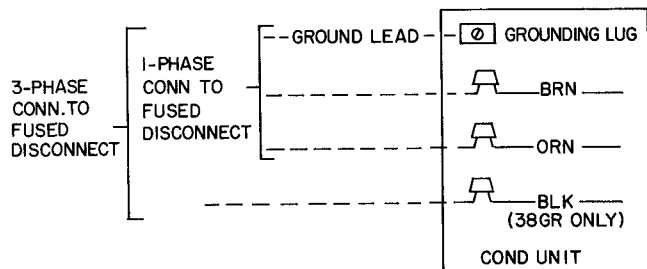

Splice Connections
 --- Field Wiring
 ——— Factory Wiring

Fig. 2 – Line Power Connections

Install a Branch Circuit Fused Disconnect of adequate size to handle unit starting current. Locate disconnect within sight of and readily accessible to the unit, per section 440-14 of National Electrical Code (NEC).

Bring Line Power Leads Into Unit – Extend leads from fused disconnect thru hole provided in base pan (Fig. 1) and into unit junction box.

CONNECT GROUND LEAD TO GROUND LUG OR SCREW IN JUNCTION BOX for safety. Connect power wiring. See Fig. 2. Splice line power leads to brown and orange pigtails on 1-phase units or brown, orange and black pigtails on 3-phase units. Use wire nuts supplied with unit. Tape each connection. When aluminum field wire is used, lubricate splices with splice compound (also supplied) before using wire nuts.

Control Power (24 v) wiring is brought thru hole provided in unit base pan (Fig. 1) and into low-voltage section of unit junction box. Splice control leads to yellow pigtails on control relay. See Fig. 3. For aluminum wire splices use factory supplied and lubricated wire nuts. Furnace or fan coil transformer must be used as 24-v supply for system as shown in Fig. 3. All 38SE units are equipped with transformer used to power contactor thru unit control circuit only, and must not be used to power thermostat circuit.

THERMOSTAT SUBBASE
HH93AZ042 OR
HH93AZ040

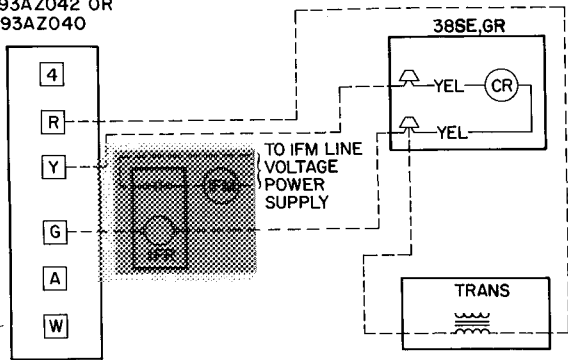

ARRANGEMENT A-(COOLING ONLY)

THERMOSTAT SUBBASE
HH93AZ042 OR
HH93AZ040

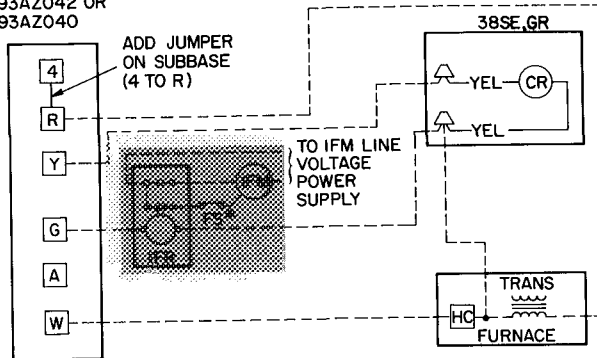

ARRANGEMENT B-ONE TRANSFORMER
(COOLING AND ONE-STAGE HEATING)

* CONNECT FS TO LOW-SPEED INDOOR FAN TERMINAL
WHEN TWO-SPEED FAN IS USED

THERMOSTAT SUBBASE
HH93AZ076

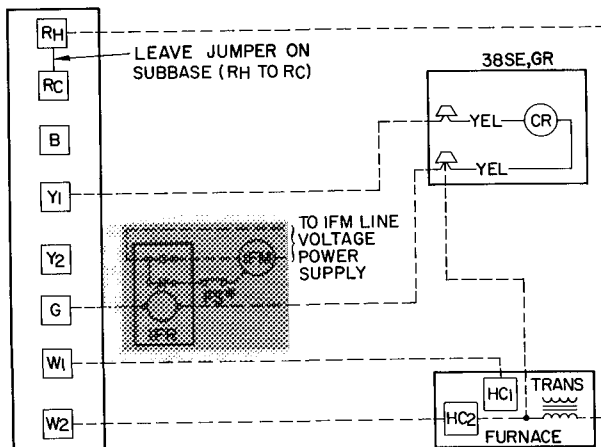

ARRANGEMENT C-ONE TRANSFORMER
(COOLING AND TWO-STAGE HEATING)

* CONNECT FS TO LOW-SPEED INDOOR FAN TERMINAL
WHEN TWO-SPEED FAN IS USED

IFR, FS and IFM are located in furnace on heating-cooling applications. If accessory IFR is required for cooling only applications, locate (IFR) in fan coil

LEGEND

- CR — Control Relay (10 va)
- FS — Fan Switch
- HC — Heating Control
- IFM — Indoor Fan Motor
- IFR — Indoor Fan Relay
- Trans — Transformer
- Field Splice
- Field Wiring
- Factory Wiring

Fig. 3 – Control Circuit Connections

START-UP INSTRUCTIONS

Energize crankcase heater a minimum of 24 hours before starting unit. To energize heater only, turn the thermostat to "Off" position and close electrical disconnect to condensing unit.

Start Procedure

1. Backseat (open) liquid and suction line service valves.
2. Set thermostat selector switch at "Off."
3. Set room thermostat to desired temperature.
4. Close electrical disconnects energizing entire system.
5. Set room thermostat at "Cool" and fan switch as desired ("Fan") ("Auto."). Unit will start in 4 to 6 minutes. Operate unit for 15 minutes, then check system refrigerant charge. See Refrigerant Charging.

Motors and controls operate satisfactorily in a range from 10% above to 10% below nominal unit voltage (Table 4).

Do not connect charging hoses during initial start procedure. (Loss of charge from this procedure may result in capacity reduction.) If necessary to add manifold gages for servicing, refer to Carrier Standard Service Techniques Manual, Chapter 1, page 1-5, Fig. 8, for bypass method of returning charge to system.

SERVICE

Table 5 – Service Data

COND UNIT	R-22 CHG* (lb-oz)	CONDENSER FAN				
		Rpm		Diam (in.)	Cfm	
		Hi	Lo		Hi	Lo
38GR002	5-10	1050	850	20	2800	2300
38GR003	5- 6	1050	850	20	2800	2300
38GR004	6- 5	1050	850	20	3100	2600
38GR045	6- 5	1050	850	20	3100	2600
38GR005	6-10	1070	870	20	3700	3200
38GR006	6-10	1070	870	20	3700	3200
38SE002	5- 8	850		20	2400	
38SE003	5-13	850		20	2400	
38SE004	7-14	850		20	2700	
38SE045	9- 8	925		20	3200	
38SE055	9- 8	1025	825	20	3900	3400

*38GR: Factory refrigerant charge adequate when condensing units are connected to Carrier approved evaporators that are the same size as (or one size larger than) condensing unit with Carrier accessory tubing

38SE: Factory refrigerant charge adequate when condensing units are connected to Carrier approved evaporators that are the same size as condensing unit. See Refrigerant Charging for details

REFRIGERANT CHARGING

38GR,SE condensing units contain correct operating charge for complete system when connected to Carrier approved evaporators. Evaporators must be same size (or one size larger than 38GR) as condensing unit with 50 ft or less of Carrier accessory tubing or 25 ft or less of field-supplied tubing of recommended size. For every 10 ft of liquid line of recommended size over 50 ft, add refrigerant charge as follows: .7 lb for 1/2-in. line, .4 lb for 3/8-in. line, 1.1 lb for 5/8-in. line. Charge adjustment may be required on other systems.

To Check, Adjust or Replace Refrigerant Charge on all Carrier approved systems, use method recommended in Table 5. Details of charging methods are listed below.

Before recharging Carrier approved systems, evacuate system to 500 microns and then weigh in refrigerant charge specified in Table 5. Check or adjust charge as required. If

necessary, refer to Carrier Standard Service Techniques Manual, Chapter 1, for system evacuation-dehydration instructions.

When 38GR,SE condensing units are connected to other than a Carrier evaporator, evacuate system and weigh in charge shown in Table 5 or use sight glass method of recharging.

CAUTION: Do not overcharge these systems. An overcharge may result in compressor damage due to refrigerant flooding.

Weight Method – Refer to Table 5 or unit nameplate for correct system refrigerant charge. Blow any refrigerant remaining in system before recharging.

When system is not evacuated, subtract the following amount from total charge:

- 38GR,SE002 – .10 lb (1.6 oz)
- 38GR,SE003,004,045,005,055,006 – .20 lb (3.2 oz)

Keep refrigerant recharge within one oz of specified charge on 002 systems and within 2 oz on 003,004,045, 005,055,006 systems.

Dial-a-charge charging cylinder is an accurate device used to recharge systems by weight. These cylinders are available at refrigeration supply firms.

Charging Chart Method

38GR THERMAL EXPANSION VALVE SYSTEMS – Use Charging Chart, Fig 4 or Fig. 5. See Carrier Standard Service Techniques Manual, Chapter 1, for procedure.

38SE CAPILLARY TUBE OR ACCURATER™ SYSTEMS – Use Charging Chart, Fig. 6, and the following procedure:

1. Operate unit a minimum of 10 minutes before checking charge.
2. Measure suction pressure by attaching a gage to suction valve service port.
3. Measure suction line temperature by attaching a service thermometer to unit suction line near compressor. (Insulate thermometer for accurate readings.)
4. Measure outdoor (condenser inlet) air dry-bulb temperature with second thermometer.
5. Refer to Charging Chart (Fig. 6). Find condenser air temperature and project horizontally to curve showing suction pressure.
6. From intersect point, project vertically downward to chart suction line temperature.
7. If unit has a higher suction line temperature than chart, add refrigerant until chart temperature is reached.
8. If unit has a lower suction line temperature than chart, bleed refrigerant until chart temperature is reached.
9. If condenser inlet air temperature or unit suction pressure changes, change to new suction line temperature on chart.

Chargemaster® Operation – Operate unit 10 minutes before using Chargemaster (Carrier Part No. 38GC680004).

1. Tape Chargemaster feeler bulb to suction line close to condensing unit. Insulate bulb. Ensure suction line is clean for good contact with bulb.
2. Connect refrigerant drum to Chargemaster inlet port with drum in position for vapor charging.
3. Connect Chargemaster outlet port to unit suction valve service port.
4. Crack valves on refrigerant drum and Chargemaster to purge lines from drum to suction valve. After purging lines, close valve on Chargemaster only.
5. Measure outdoor air dry-bulb temperature.

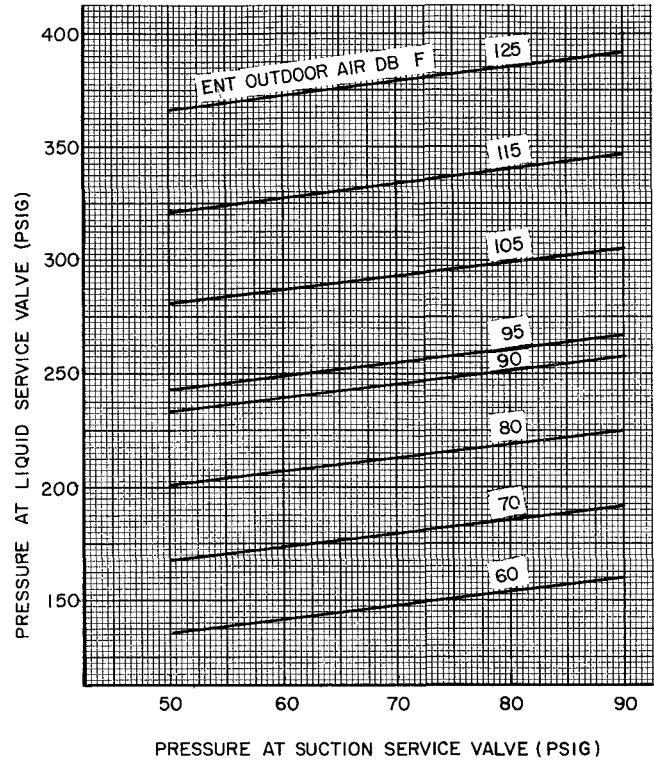

Fig. 4 – 38GR002,003,004,045,005 Charging Chart – TXV Systems

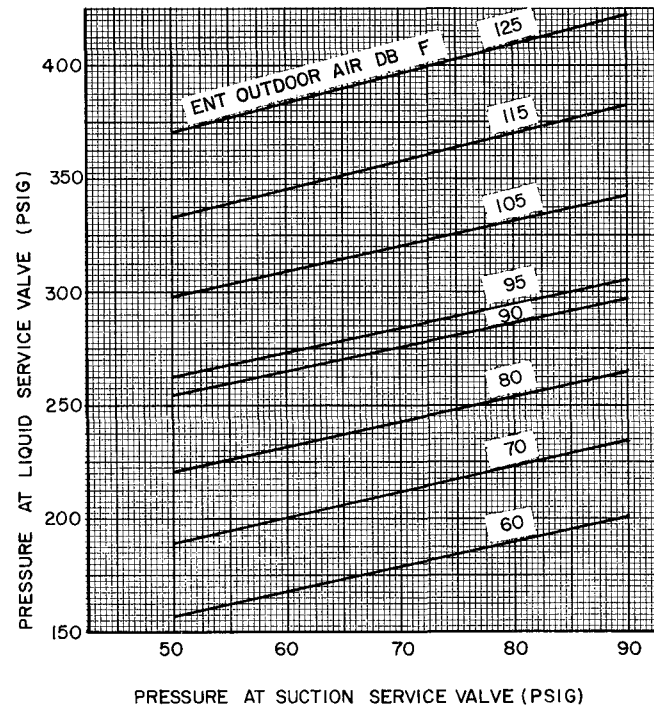

Fig. 5 – 38GR006 Charging Chart – TXV Systems

6. Crack unit suction valve and read evaporator temperature at red needle position on Chargemaster temperature gage and suction line temperature at black needle position.

CAUTION: Do not read evaporator temperature with Chargemaster valve open.

Table 6 – Refrigerant Charging Methods (Carrier Approved Systems)

COND UNIT	METHODS OF CHECKING OR ADJUSTING CHARGE			METHODS FOR COMPLETE RECHARGING		
	System Refrigerant Control			System Refrigerant Control		
	AccuRater™	Capillary Tube	TXV	AccuRater	Capillary Tube	TXV
38GR	Chargemaster®		Charging Chart or Sight Glass	Weight Method Plus Chargemaster		Weight Method Plus Charging Chart or Sight Glass
38SE	Chargemaster or Charging Chart		Sight Glass	Weight Method Plus Chargemaster or Charging Chart		Weight Method Plus Sight Glass

NOTE: 38SE operates at lower head pressure than comparable units. Do not expect as high pressure when charging or adding charge.

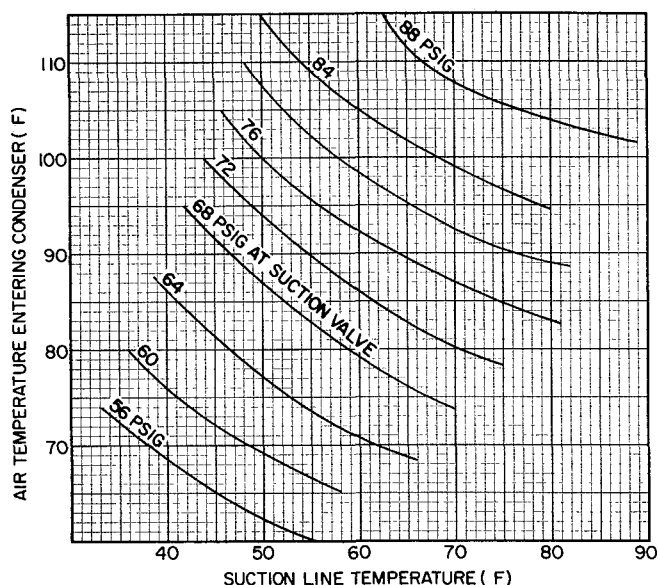

Fig. 6 – 38SE Charging Chart
(Capillary Tube or AccuRater Systems with or without Suction-Liquid Line Heat Interchange)

- Enter Chargemaster Charging Chart, Table 7 or 8, at outdoor air temperature (step 5) and evaporator temperature (step 6). Find the suction line temperature required for correct system charge. If actual suction line temperature (step 6) is higher than table value, the system is undercharged. If suction line temperature is lower than table value, the system is overcharged.

Example: At outdoor air temperature of 85 F and evaporator temperature of 44 F, the system will be correctly charged at 71 F ± 2 F suction line temperature. See Table 8.

- Add charge by slowly opening Chargemaster valve. If necessary, reduce charge by bleeding at liquid line service valve. Check outdoor air and evaporator temperature during procedure. If they change, refer back to Suction Line Temperature table for new value.

Correct use of Chargemaster ensures an optimum refrigerant charge will be in system when conditions and system components are normal. However, the Chargemaster does not solve or fix system abnormalities. It indicates correct charge for condition of system. It will not make corrections for dirty filters, slow fans, excessively long or short suction lines or other abnormal conditions. This charging device ensures that a correct relationship exists between outdoor temperature, evaporator temperature, and suction line temperature on a specific system.

Table 7 – Chargemaster Charging Chart
(38GR Capillary Tube or AccuRater Systems)

OUTDOOR TEMP (F)	EVAPORATOR TEMP (F)										
	21	25	28	31	34	37	40	43	45	48	
	Suction Line Temperatures										
60	32	40	51								
62	30	38	49								
64	28	37	47	60							
66	27	35	45	57							
68		34	43	54	67						
70		32	41	52	64						
72		31	39	50	61	72					
74		30	37	48	58	69					
76		29	36	46	56	66					
78		27	35	44	54	63	75				
80		26	33	42	52	61	72				
82			32	40	50	59	68	80			
84			31	38	48	57	66	76			
86			29	37	46	55	63	73	85		
88				35	44	53	61	70	81		
90				34	42	51	59	68	78	90	
92				33	41	49	57	65	75	86	
94					39	47	55	63	72	83	
96					38	45	53	61	70	80	
98					36	44	51	59	67	77	
100						42	49	57	65	75	
102							41	48	55	63	73
104							39	46	53	61	70
106								45	51	59	68
108								43	49	57	65
110								41	47	55	63
112									46	53	61
114										50	59

Example

*Saturated evaporator temperature which is the equivalent temperature of pressure taken at the condensing unit suction service valve

Sight Glass Method – A satisfactory operating charge can be obtained on thermal expansion valve systems by charging to a clear sight glass. For optimum charge, elevate high-side pressure to 380 ± 10 psig by blocking condenser fan discharge or condenser entering air. Charge to a clear sight glass while holding high-side pressure constant. For peak efficiency, adjust charge to yield a liquid refrigerant temperature at the evaporator that is approximately the same as outdoor dry-bulb temperature.

Table 8 – Chargemaster[®] Charging Chart
(38SE Capillary Tube or AccuRater[™] Systems)

OUTDOOR TEMP (F)	EVAPORATOR TEMP (F)											
	32	34	36	38	40	42	44	46	48	50	52	54
	Suction Line Temperature (F)											
60	60											
65	49	58	65									
70	41	48	58	68	70							
75	35	41	48	58	68	75						
80	31	36	42	50	59	69	80					
85			38	44	52	62	72	82				
90				40	47	53	61	69	78			
95					42	48	53	59	67	79		
100						43	47	52	58	68	88	
105							44	48	53	60	75	104
110									49	54	65	80
115										50	62	69

Example

UNIT PROTECTION

High-Pressure Relief Valve is located in compressor when so equipped. Relief valve opens at a pressure differential of approximately 450 – 550 psi between suction and discharge. Valve permits pressure equalization at running condition described above and during unit shutdown. A hissing sound during pressure equalization does not indicate bad valves.

High Pressurestat is located on unit liquid line. High pressurestat settings are: cutout, 425 ± 5 psig; cut-in, 320 ± 20 psig.

Low Pressurestat is located on unit suction line. Low pressurestat settings are: cutout, 31 ± 4 psig, cut-in, 60 (+15, -0) psig.

Internal Temperature And/Or Current Sensitive Overloads reset automatically when internal motor temperatures drop to a safe level (overload may require up to 30 minutes to reset). When internal overload is suspected of being open, check by using an ohmmeter or continuity tester. If necessary, refer to Carrier Standard Service Techniques Manual, Chapter 2, for complete instructions.

Outdoor Fan Thermostat (38SE055 and 38GR units) switches fan to high speed (Table 5) when outdoor temperature reaches 90 F – maintains proper condensing temperature at high outdoor air temperatures. Thermostat is located on Control Panel, Fig. 7.

Filter-Drier is installed in liquid line.

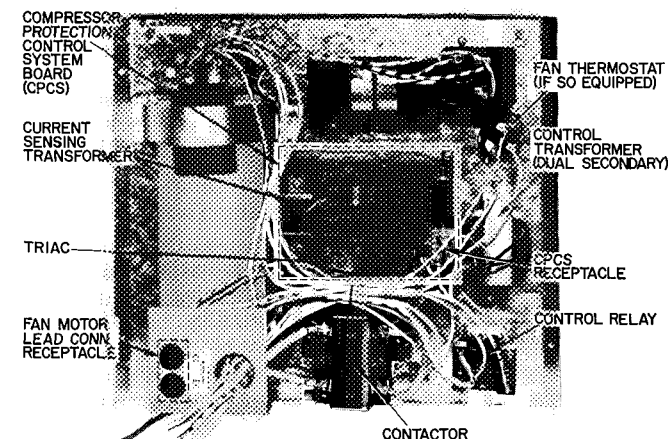

Fig. 7 – Control Panel (Cover Removed)

Compressor Protection Control System (CPCS – Solid State, Fig. 7) provides: compressor motor locked rotor protection; compressor start winding protection; compressor motor running overload protection; compressor over-temperature protection; contactor anti-chatter protection.

The CPCS also provides for a 4- to 6-minute delay before restarting compressor after shutdown for any reason. If compressor loading was light at the moment compressor was shut off, the delay will be approximately 4 minutes. If loading was heavy, the delay will be approximately 6 minutes. The CPCS board is located on control panel beneath a sheet metal protective cover. To troubleshoot the CPCS, remove protective sheet metal cover, and use unit label diagram or wiring booklet with Control Circuit Troubleshooting Chart, page 9.

TROUBLESHOOTING CHART NOTES (Page 9):

CAUTION: Do not operate unit with CPCS receptacle disconnected from board and compressor current transformer connected. This will burn up CPCS board.

1. Ensure thermostat calls for cooling before troubleshooting unit.
2. To disconnect plug from receptacle on CPCS board – press in tabs located on the receptacle and pull plug gently while holding tabs. Do not pull on wiring.
3. When performing troubleshooting checks, CPCS receptacle must be plugged into CPCS board.
4. Receptacle female connections, which do not grip the male pin tightly, may be repaired with a small pen knife.
5. When taking meter readings at CPCS receptacle, bottom meter probe into terminal hole to ensure good electrical contact.
6. Replace CPCS board if electrical short circuit causes compressor failure. An electrical short in compressor can short the triac (electronic switch located on CPCS board). Triac may fail in a closed (conducting) position and not open the control circuit.

PUMPDOWN PROCEDURE

The 38GR,SE units may be pumped down in order to make repairs on low side of system without losing complete refrigerant charge.

1. Attach pressure gage to suction service valve gage port.
2. Frontseat the liquid line valve.
3. Jumper low-pressure switch.
4. Start unit and run until suction pressure reaches 5 psig (see Caution).
5. Shut unit off and frontseat suction valve.
6. Vent remaining pressure to atmosphere.

CAUTION: The 38GR condensers will hold only factory supplied amount of refrigerant. Additional refrigerant may cause units to cycle on high pressurestat (indicated by a high discharge pressure or a sudden rise of suction pressure) before suction pressure reaches 5 psig. If this occurs, shut unit off immediately, frontseat suction valve and vent remaining pressure to atmosphere.

COMPRESSOR SERVICE

Unit Single-Phase Compressors of the split capacitor (PSC) type require an equalized system pressure to start. When supply voltage is within 10% limit and compressor does not start, give compressor a temporary capacitance boost. See

CONTROL CIRCUIT TROUBLESHOOTING CHART

CAUTION: Compressor current sensing transformer is located on compressor protection control system (CPCS) board. Shut line power off before attempting any service operations (because of presence of high voltage).

Before attempting any corrective action, wait 8 minutes after power is supplied to permit CPCS time delay period to end. If control circuit is broken and unit has no time delay (or if time delay is over 8 minutes), replace CPCS board.

IMPROPER UNIT OPERATION

STEP 1

Check contactor operation

CONTACTS CLOSE IMMEDIATELY, UNIT DOES NOT RUN → CPCS Board and control circuit function. Check compressor, run capacitor, start gear and internal compressor protection

CONTACTS WON'T STAY CLOSED. OR, CONTACTS OPEN BEFORE ROOM THERMOSTAT IS SATISFIED → Check system pressures and current draw

CONTACTS NEVER CLOSE

STEP 2

Check unit voltage at terminals 21 and 23 on contactor

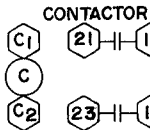

VOLTAGE LOW OR NO VOLTAGE → Obtain correct voltage

VOLTAGE CORRECT

STEP 3

Check control circuit and current transformer wiring and connections

LOOSE CONNECTIONS OR IMPROPER WIRING → Repair connection or correct wiring

WIRING AND CONNECTIONS GOOD

STEP 4

Check output at 5 va secondary of unit voltage transformer (at terminals 2 and 10 on CPCS receptacle) Should be 23-30 volts

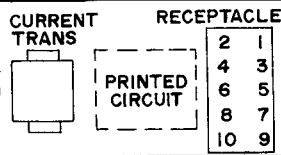

VOLTAGE LOW OR NO VOLTAGE → Replace transformer

BOARD VOLTAGE CORRECT

STEP 5*

Check output at 25 va secondary of unit voltage transformer (at CPCS receptacle terminal 3 and C2 on contactor) Should be 23-30 volts

VOLTAGE LOW OR NO VOLTAGE → Replace transformer

VOLTAGE CORRECT

STEP 6*

Check contactor voltage at C1 and C2 terminals on contactor (C) Should be 23-30 volts

VOLTAGE CORRECT → Replace contactor

NO VOLTAGE

STEP 7*

Check control circuit voltage from contactor (C) terminal C2 to terminal 1 on control relay. Should be 20-29 volts

VOLTAGE IS LOWER THAN 20 VOLTS† → Check indoor unit power, indoor transformer, thermostat or control relay

VOLTAGE CORRECT

STEP 8*

Check control circuit voltage from contactor (C) terminal C2 to junction of high-pressure switch (HPS) and low-pressure switch (LPS) Should be 20-29 volts

VOLTAGE IS LOWER THAN 20 VOLTS† → System pressure too high or bad high-pressure switch

VOLTAGE CORRECT

STEP 9*

Check control circuit voltage from contactor (C) terminal C2 to terminal 8 on CPCS receptacle. Should be 20-29 volts

VOLTAGE IS LOWER THAN 20 VOLTS† → System pressure too low, bad low-pressure switch or open internal protector (IP)

VOLTAGE CORRECT

STEP 10

Replace CPCS board

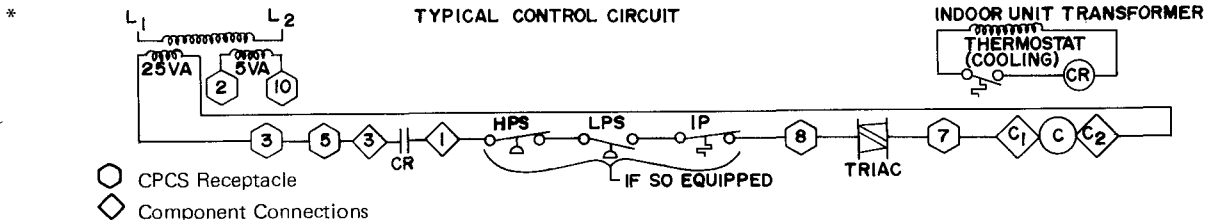

† Voltage reading less than 20 volts may result from feedback circuit.

Carrier Standard Service Techniques Manual, Chapter 2, for details. Use a 130 mfd start capacitor. Connect wires with insulated probes to each capacitor terminal. Touch probes to each side of run capacitor or to compressor motor terminals R and S. Start compressor; *pull probes away after 3 seconds. Discharge start capacitor.* Run compressor for 10 minutes, then shut off and allow system pressure to equalize. Try restarting without boost capacitor. If after 2 attempts (without boost capacitor) the compressor does not start, add an accessory start capacitor relay package.

Unit Single-Phase Compressors that are equipped with a compressor *start thermistor (PTC device)*. If compressor will not start, check the thermistor with an ohmmeter as follows:

1. Shut off all power to unit and wait 5 minutes for thermistor to cool to outdoor temperature.
2. Measure resistance of thermistor with ohmmeter. Normal resistance readings are 50 to 90 ohms at 75 F outdoor temperature.
3. If ohmmeter resistance reading is 0 or much higher than 90 ohms, the thermistor is defective and must be replaced.

If start thermistor (PTC device) is good and compressor will not start, disconnect the thermistor from starting circuit and give compressor a temporary capacitance boost as described above. Run compressor for 10 minutes, then shut off and allow system pressure to equalize. Reconnect start thermistor and try restarting compressor without boost capacitor. If after 2 attempts the compressor does not start, remove thermistor and add an accessory start capacitor relay package.

→ Compressor Removal

38GR; 38SE002,003,004 UNITS — See Table 9 for compressor information and Fig. 8 for component location. Shut off power to unit. Vent refrigerant to atmosphere or use refrigerant removal methods shown in Carrier Standard Service Techniques Manual, Chapter 1.

1. Remove unit top cover (grille). Open or remove service door.
2. Disconnect fan motor leads from control panel located on service door. See Fig. 7 and refer to Service Door on page 3. Remove 6 screws holding fan motor orifice assembly in place and lift assembly from unit.
3. Compressor outer sound shield is fastened to tube sheets and to base pan. Loosen screws and remove sound shield by sliding it straight up using tube sheets as guides.
4. (38SE only) — Warp top cover of inner compressor sound shield upward to clear compressor process tube. Carefully slide cover over the tubing.

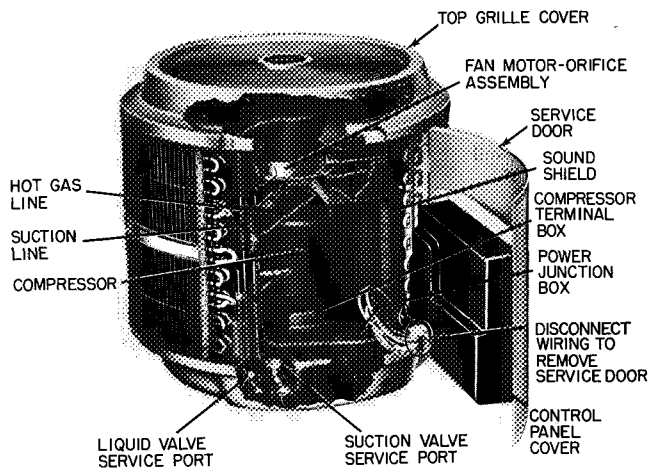

Fig. 8 — 38GR Condensing Unit with Service Door Open

5. (38SE only) — Slide inner compressor sound shield terminal box cover upward and out.
6. Remove compressor terminal box cover, disconnect and remove compressor power leads.
7. (38SE only) — Lift off inner compressor sound shield.
8. Unsweat suction and hot-gas lines.
9. Remove compressor hold-down bolts. Lift compressor out thru top of unit.

Table 9 — Compressor Data

COND UNIT	V/PH	PRODUCTION COMPRESSOR*	OIL RECHARGE (oz)
38GR002---	230/1*	38GL400324	40.5
38GR002310		MD2723CB	43.2
38GR003---		38GR400234	31.5
38GR003310		MC3423CB	43.2
38GR004---		38GC401564	45.0
38GR004310		MC4023CB	43.2
38GR045---		PC4626AD	76.0
38GR005---		PC5326AD	76.0
38GR006---		PC6725AB	76.0
38GR003---		200/3	RF3522CJ
38GR003410	MF3423CB		43.2
38GR004---	RF3922CJ		50.4
38GR004410	MF4023CB		43.2
38GR045---	PF4626AD		76.0
38GR005---	PF5326AD		76.0
38GR006---	PF6725AA	76.0	
38GR003---	230/3	RG3522CJ	50.4
38GR003510		MG3423CB	43.2
38GR004---		RG3922CJ	50.4
38GR004510		MG4023CB	43.2
38GR045---		PG4626AD	76.0
38GR005---		PG5326AD	76.0
38GR006---	PG6725AA	76.0	
38GR004---	460/3	RH3922CJ	50.4
38GR004610		MH4023CB	43.2
38GR045---		PH4626AD	76.0
38GR005---		PH5326AD	76.0
38GR006---	PH6725AA	76.0	
38SE002---	230/1	MD2023CB	43.2
38SE003---		MD2723CB	43.2
38SE004---		MC3423CB	43.2
38SE045---		PC4626AD	76.0
38SE055---		PC5326AD	76.0

--- Tabular data shown applicable to all models except those shown italicized 000.

*Refer to Service Parts catalog for replacement compressor model numbers. The 38GR,SE single-phase compressors include start assist.

38SE045,055 UNITS

1. Open and remove service door. See Fig. 7 and refer to Service Door on page 3.
2. Disconnect fan motor leads and crankcase heater leads from control panel located on service door.
3. Remove cover plate on compressor terminal box and disconnect all leads.
4. Remove 4 screws holding compressor plastic sound shield in place. Slide shield upward 6 to 10 inches.
5. Unsweat suction and hot-gas lines at compressor (disconnect convenient connection at sight glass or filter-drier).
6. Remove 3 screws holding coil to base pan.
7. From front of unit (coil-emblem side) lift complete disconnected coil-fan-top cover assembly off from compressor-base pan assembly.

8. Remove compressor from base pan and replace with new compressor. Install crankcase heater (step 2) on new compressor.
9. Replace coil-fan-top cover assembly on compressor-base pan assembly; reconnect all joints and wiring; recharge unit.

COMPATIBLE FITTING REPAIR

Leaking Mechanical Connection — Frontseat condensing unit service valves and relieve refrigerant pressure in tubing. Back locknut off compatible fitting onto tube. Cut fitting between threads and seal ring head as shown in Fig. 9. Remove tubing section remaining in threaded portion of fitting. Discard locknut.

Clean, flux, and insert new tube end into remaining portion of compatible fitting. *Wrap valve base in wet rag.* Heat and apply low-temperature (450 F) solder.

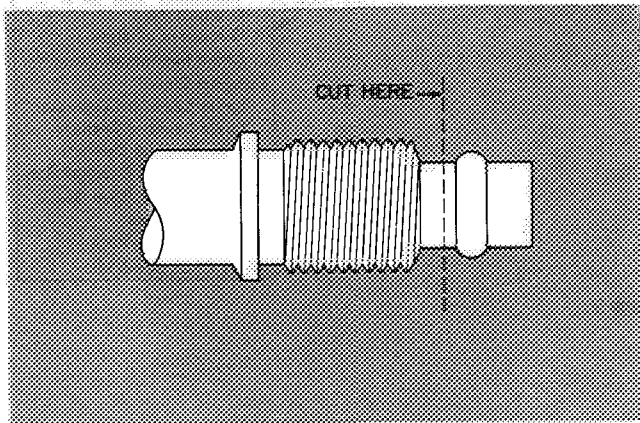

Fig. 9 — Repair of Mechanical Connection

Leaking Sweat Connection — Frontseat service valves and relieve refrigerant pressure in tubing. Clean and flux area around leak and apply low-temperature (450 F) solder.

Evacuate or purge evaporator coil and tubing system. Add refrigerant charge (see charging instructions).

CONDENSER

Coil Cleaning — *Ensure power to unit is shut off.* Clean the condensing unit coil at the beginning of every cooling season or more often if required. Use ordinary garden hose at a pressure high enough to clean efficiently. For best results, unscrew and remove unit top cover (grille). Insert hose nozzle between fan blades and spray coil fins from inside-to-outside the unit. If unit has a double-row coil, loosen screws to separate coils, and flush dirt toward outside of both coils. Flush dirt from base pan by spraying water thru top of unit. Avoid splashing mud on coil or water on the fan motor.

Metal Fan — Required fan position is shown in Fig. 10. Adjust fan by loosening setscrew and moving fan blades up or down.

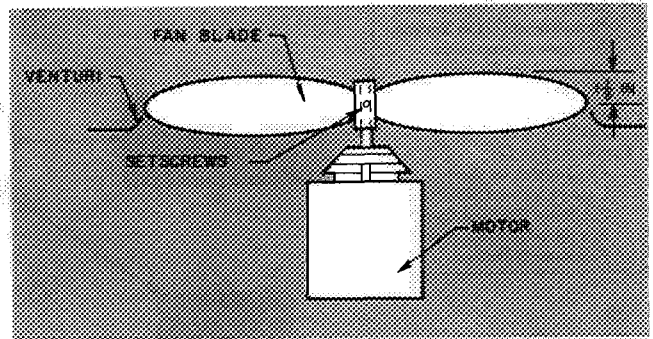

Fig. 10 — Condenser Fan Position

Fan Motor Removal

1. Shut off power to unit.
2. Remove unit top cover (grille). Open or remove service door. With door open, remove control panel cover.
3. Disconnect fan motor leads (3) from control panel located on service door. See Fig. 7.
4. Remove fan from motor shaft by loosening setscrew and pulling upward on fan hub.
5. Remove bolt holding fan motor to motor mounting bracket. Remove motor with wiring thru top of unit. To replace motor, place motor on self-positioning motor mounting bracket and retighten bolt.

Before replacing metal fan, be sure moisture protectors are in place on motor shaft.

LUBRICATION

Fan Motor Bearings — Oiling holes are provided at each end of condenser fan motor. Remove fan motor and lubricate motor with 32 drops (16 drops per hole) of SAE-10 nondetergent oil at intervals described below:

- a. Annually, when environment is very dirty, ambient temperature is higher than 105 F, and average unit operating time exceeds 15 hours a day.
- b. Every 3 years when environment is reasonably clean, ambient temperature is less than 105 F and unit operating time averages 8 to 15 hours a day.
- c. Every 5 years when environment is clean, ambient temperature is less than 105 F and unit operating time averages less than 8 hours a day.

Compressor contains factory oil charge. When oil is lost, see Table 9 for oil recharge and Carrier Standard Service Techniques Manual, Chapter 1, page 1-21, for instructions. Use Carrier PP33-1, Texaco Capella B or Suniso 3G oil.

TROUBLESHOOTING CHART*

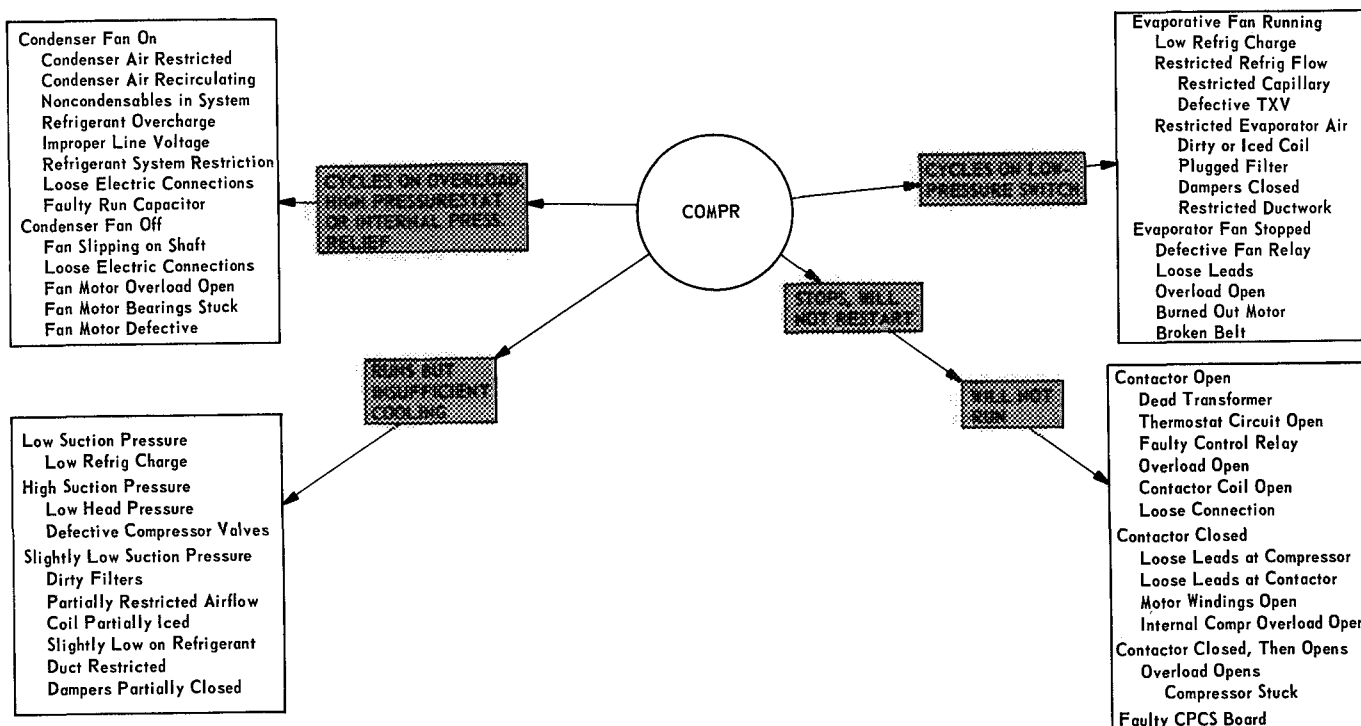

*To troubleshoot control circuit, see Control Circuit Troubleshooting Chart, page 9.

For replacement items use Carrier Specified Parts.

Manufacturer reserves the right to discontinue, or change at any time, specifications or designs without notice and without incurring obligations.

Tab 4 Form 38SE-3SI Supersedes 38GR-3SI, 38SE-2SI Printed in U.S.A. 1076 3-75 PC 101 Catalog No. 533-827

Book	1
Tab	3a