

# **3M**

## **Dynapro™**

### **ET 350 Monitor**

*User's Installation Guide*

**Read and understand all safety information  
before installing and using this product.**

## Copyright

This manual is © 3M 2002. All rights reserved.

Reproduction of the contents of this copyrighted manual in whole or in part, by any means, electronic or mechanical, for any purpose, without written permission of 3M Touch Systems, a subsidiary of 3M, is prohibited.

## Notice

Given the variety of factors that can affect the use and performance of a 3M Touch Systems Product, including that solid state equipment has operation characteristics different from electromechanical equipment, some of which factors are uniquely within User's knowledge and control, it is essential that User evaluate the 3M Touch Systems product to determine whether it is suitable for User's particular purpose and suitable for User's method of application. 3M Touch Systems' statements, engineering/technical information, and recommendations are provided for User's convenience, but their accuracy or completeness is not warranted. 3M Touch Systems products are not specifically designed for use in medical devices as defined by United States federal law. 3M Touch Systems products should not be used in such applications without 3M Touch Systems' express written consent. User should contact its sales representative if User's opportunity involves a medical device application.

## Important notice to purchaser

Specifications are subject to change without notice. 3M Touch Systems' Products are warranted to meet their published specifications from the date of shipment and for the period stated in the specification. **3M Touch Systems makes no additional warranties, express or implied, including but not limited to any implied warranties of merchantability or fitness for a particular purpose.** User is responsible for determining whether the 3M Touch Systems Products are fit for User's particular purpose and suitable for its method of production, including intellectual property liability for User's application. If a Product is proven not to have met 3M Touch Systems' warranty, then 3M Touch Systems' sole obligation and User's and Purchaser's **exclusive remedy**, will be, at 3M Touch Systems' option, to repair or replace that Product quantity or to refund its purchase price. 3M Touch Systems has no obligation under 3M Touch Systems' warranty for any Product that has been modified or damaged through misuse, accident, neglect, or subsequent manufacturing operations or assemblies by anyone other than 3M Touch Systems. **3M Touch Systems shall not be liable in any action against it in any way related to the Products for any loss or damages, whether non-specified direct, indirect, special, incidental or consequential (including downtime, loss of profits or goodwill) regardless of the legal theory asserted.** (11/01)

## Edition

December 2002

Document Number: 19153 (Rev. 1.5)

## Trademarks

3M Dynapro, MicroTouch, TouchSurround, and Near Field Imaging are trademarks of 3M. Windows and Microsoft are trademarks of Microsoft Corporation.

# Product safety information

## Intended Use

The 3M Dynapro™ ET 350 monitor (specifically, monitor models ET 350R, ET 350L2, and ET 350L3) is intended to provide touch screen functions when connected to a host computer in an industrial setting. The ET 350 monitor is not intended for use in hazardous locations.

## Warning

### **To reduce the risk of fire or explosion which could result in serious personal injury or death:**

- Do not install or use this product in a hazardous location.
- When using a flammable or combustible cleaning solution or fluid on or near the ET 350 monitor, refer to the cleaner manufacturer's material safety data sheet and follow all instructions and recommendations.

### **To reduce the risk of fire or electric shock which could result in serious personal injury or death:**

- Follow all product and accessory installation instructions.
- Any servicing or other procedures not described in this manual are to be performed only by 3M Touch Systems service personnel.
- For the ET 350R monitor in a Pollution Degree 3 environment, install the unit in an enclosure that is sealed to a NEMA 4X/IP66 standard.
- Install the ET 350 monitor close to the power source so the unit can be easily and quickly disconnected. For permanently connected equipment, a readily accessible disconnect device must be incorporated in the fixed wiring.
- Engineer the installation of the ET 350 monitor to take into account the operating environment (e.g., thermal, shock/vibration factors).
- Provide a clean, reliable grounding.
- When connecting power with fixed field wiring, the power cable must be double insulated. A clear, flexible insulator (supplied) must cover the portion of the cable that is not double insulated when connecting to a terminal strip connector.
- Wiring installation should be done by a licensed journeyman electrician and must comply with federal and local electrical codes.
- When replacing a fuse or other part, use a part of the type and rating specified by 3M Touch Systems.
- Properly install the ET 350R monitor so that it is environmentally sealed to NEMA 4X/IP66 standard.
- Properly install the ET 350R monitor with a NEMA 4X/IP66 gasket that is undamaged and effective.
- Do not use an ET 350 monitor that is not rated to NEMA 4X/IP66 in environments that require a NEMA 4X/IP66 seal.
- Do not damage any ET 350 monitor gaskets.

 **Warning**

**To reduce the risk of electric shock which could result in serious personal injury or death:**

- Do not open the power supply in the ET 350 monitor. It contains hazardous voltages. The power supply has no user-serviceable parts or adjustments inside.
- Make sure that the ground potential difference between the ET 350 monitor and the host computer is less than 2V.
- Provide adequate strain relief for all communications and power cables.
- Before removing the ET 350 monitor from its mounting, disconnect power to the unit.

**To reduce the risk of electric shock or mechanical impact which could result in serious personal injury or death:**

- Apply a "safe touch" setting, especially if the monitor is running an application or is in a setting where safety is a concern.
- Do not use a non-Windows operating system screen saver that may affect the "safe touch" setting and could in turn cause connected peripheral equipment to start or stop inadvertently.
- Set the safe touch setting correctly, with the number of minutes entered for the Windows operating system's energy saver being at least one minute greater than the time entered for the Windows operating system screen saver.
- If your ET unit has a display power management system (DPMS) that is configurable from the display's on-screen utility menu, do not turn off the DPMS.

 **Caution**

**To reduce the risk of minor or moderate injury from contact with cleaning solutions or fluids, through means such as ingestion and skin contact:**

- Refer to the cleaner manufacturer's material safety data sheet and follow all instructions and recommendations.

**To reduce the risk of electric shock or fire which may result in minor or moderate injury or cause property damage:**

- If the ET 350 monitor will be used in corrosive environments, it is the responsibility of the user to test and evaluate the monitor in those environments. The monitor, as shipped, has not been evaluated for use in corrosive environments and using it in such environments, without evaluation and testing, may lead to unsafe conditions.

**To reduce the risk of muscle strain which may result in minor or moderate injury or cause property damage:**

- Avoid using the ET 350 monitor for long periods of time without breaks.

**To reduce the risk of eye strain which may result in minor or moderate injury or cause property damage:**

- Use the monitor where there is neither too much ambient light nor glare on the screen.

**To reduce the risk of environmental contamination which may result in minor or moderate injury or cause property damage:**

- Dispose of the monitor according to applicable governmental regulations.

 **Warning**

**To reduce the risks associated with electric shock and/or burn-related injury that could result in death or serious injury and/or property damage:**

- Do not open the power supply in the ET unit. It contains hazardous voltage/hazardous energy. The power supply has no user-serviceable parts or adjustments inside.
- Avoid contact with connectors on power terminal strip unless the power has been disconnected.
- Avoid exposed electrical contacts inside the ET unit.

**To reduce the risks associated with electrical shock or fire which, if not avoided, could result in death or serious injury and/or property damage:**

- If the ET unit is mounted using a NEMA 4X panel gasket, install the unit in a Listed (UL) enclosure.

**To reduce the risks associated with mechanical function which, if not avoided, could result in property damage:**



- Do not operate the ET unit in conditions outside of the operational specifications.

**To reduce the risks associated with fire and explosion which, if not avoided, could result in death or serious injury and/or property damage:**

- Do not use flammable or combustible cleaners on or near the monitor.

## Explanation of safety labels

The following safety symbols are used on the exterior and interior of the ET 350 monitor:

Symbol	Meaning
	<b>Attention:</b> Refer to accompanying documents
	<b>Caution:</b> Risk of electric shock



# Renseignements sur la sécurité du produit

## Utilisation

Le moniteur 3M Dynapro™ ET 350 (modèles ET 350R, ET 350L2 et ET 350L3) sert à fournir des fonctions pour écran tactile lorsqu'il est branché à un ordinateur hôte dans un environnement industriel. Le moniteur ET 350 n'est pas destiné à être utilisé dans des endroits dangereux.



## Avertissement

### **Afin de réduire les risques d'incendie ou d'explosion causant des blessures corporelles sérieuses ou mortelles :**

- N'installez pas ou n'utilisez pas ce produit dans un lieu dangereux.
- Lorsque vous utilisez une solution ou un fluide nettoyant inflammable ou combustible sur ou près du moniteur ET 350, veuillez vous référer à la fiche technique du fabricant du matériel de nettoyage et suivez toutes les instructions et recommandations.

### **Afin de réduire les risques d'incendie ou de choc électrique causant des blessures corporelles sérieuses ou mortelles :**

- Suivez toutes les instructions d'installation du produit et des accessoires.
- Tout entretien ou autre procédure qui n'est pas décrite dans ce manuel doit être réalisé seulement par le personnel du service de 3M Touch Systems.
- Pour le moniteur ET 350R dans un environnement à pollution de type 3, installez l'unité dans une enveloppe scellée selon le standard NEMA 4X/IP66.
- Installez le moniteur ET 350 à proximité de la source d'alimentation afin que l'unité puisse être débranchée facilement et rapidement. Pour l'équipement branché en permanence, un dispositif de débranchement facile d'accès doit être incorporé au filage fixe.
- Supervisez l'installation du moniteur ET 350 et prenez en considération l'environnement d'opération (comme par exemple les facteurs thermiques et l'exposition aux chocs et aux vibrations).
- Fournissez une mise à terre fiable et propre.
- Au moment du branchement de l'alimentation avec câblage d'excitation fixe, le câble d'alimentation doit avoir une double isolation. Un isolant clair et flexible (fourni) doit couvrir la portion du câble qui n'a pas de double isolement lors du branchement à un connecteur de plaque à bornes.
- L'installation du câblage devrait être effectuée par un maître électricien autorisé et doit respecter les codes du bâtiment fédéraux et provinciaux.
- Lors du remplacement d'un fusible ou d'une autre pièce, utilisez une pièce du type et du régime nominal indiqué par 3M Touch Systems.
- Installez solidement le moniteur ET 350R pour qu'il soit dans un environnement scellé selon les standards NEMA 4X/IP66.
- Installez solidement le moniteur ET 350R avec un joint statique NEMA 4X/IP66 intact et fonctionnel.
- N'utilisez pas le moniteur ET 350 qui n'est pas du régime nominal NEMA 4X/IP66 dans des environnements qui exigent le sceau NEMA 4X/IP66.
- N'endommagez pas les joints statiques du moniteur ET 350.



### Avertissement (suite)

**Afin de réduire le risque d'électrocution qui peuvent causer des blessures corporelles sérieuses ou mortelles :**

- N'ouvrez pas l'alimentation électrique du moniteur ET 350. Il contient des voltages dangereux. L'alimentation électrique n'a pas de pièces à remplacer par l'utilisateur ou de dispositifs de réglage à l'intérieur.
- Assurez-vous que la différence potentielle de mise à terre entre le moniteur ET 350 et l'ordinateur hôte est de moins de 2V.
- Installez un réducteur de tension adéquat pour toutes les communications et les câbles d'alimentation.
- Débranchez l'alimentation de l'unité avant de sortir le moniteur ET 350 de son support.

**Afin de réduire les risques d'électrocution ou de collision mécanique causant des blessures corporelles sérieuses ou mortelles :**

- Sélectionnez un réglage "safe touch", surtout si le moniteur tourne avec une application ou si le réglage de la sécurité est en question.
- Utilisez seulement un économiseur d'écran pour système d'exploitation Windows sinon cela pourrait affecter le réglage "safe touch" et pourrait démarrer et stopper les périphériques qui y sont branchés par inadvertance
- Réglez correctement les paramètres safe touch où le nombre de minutes entrées pour l'économiseur d'énergie du système d'exploitation Windows doit être au moins une minute de plus que le temps entré pour l'économiseur d'écran du système d'exploitation Windows.
- Ne mettez pas le système de gestion de l'alimentation de l'afficheur (DPMS) hors tension, qui est configurable à partir du menu Utilitaire à l'écran de l'afficheur.



### Avertissement

**Afin de réduire les risques de blessures mineures ou modérées provenant du contact avec des solutions ou de fluides nettoyants, par ingestion et au contact de la peau :**

- Veuillez vous référer à la fiche technique sur la sécurité du fabricant du matériel de nettoyage et suivre toutes les instructions et recommandations.

**Afin de réduire les risques d'électrocution ou d'incendie causant des blessures mineures ou modérées ou des dommages à l'équipement :**

- Si le moniteur ET 350 doit être utilisé dans des environnements corrosifs, il est de la responsabilité de l'utilisateur de tester et d'évaluer le moniteur dans de tels environnements. Le moniteur, tel que livré, n'a pas été évalué pour une utilisation dans des environnements corrosifs et son utilisation dans de tels environnements, sans évaluation et test préalables, peut créer des conditions d'utilisation non-sécuritaires.

**Afin de réduire les risques de fatigue musculaire causant des blessures mineures ou modérées ou des dommages à l'équipement :**

- N'utilisez pas le moniteur ET 350 pour de longues périodes sans pause.

**Afin de réduire les risques de fatigue de l'oeil causant des blessures mineures ou modérées ou des dommages à l'équipement :**

- Utilisez le moniteur dans des endroits qui ne sont pas trop éclairés ou produisant des reflets sur l'écran.

**Afin de réduire les risques de contamination environnementale causant des blessures mineures ou modérées ou des dommages à l'équipement :**

- Disposez du moniteur selon les lois gouvernementales applicables.



 **Avertissement**

**Pour réduire les risques de décharges électriques ou de brûlures susceptibles, faute de précaution, de causer la mort, des blessures graves et/ou des dommages matériels :**

- Ne pas ouvrir le bloc d'alimentation du terminal ET. Il comporte des tensions dangereuses. Le bloc d'alimentation ne renferme aucune pièce ni aucun dispositif de réglage remplaçable par l'utilisateur.
- Éviter tout contact avec les connecteurs du bornier avant d'avoir coupé l'alimentation.
- Ne pas toucher aux fils électriques à découvert à l'intérieur du terminal ET.

**Pour réduire les risques de décharges électriques ou d'incendie susceptibles, faute de précaution, de causer la mort, des blessures graves et/ou des dommages matériels :**

- Si le terminal ET a été assemblé à l'aide d'un joint NEMA 4X, installer le terminal dans un endroit homologué UL.

**Pour réduire les risques de problème mécanique susceptibles, faute de précaution, de causer la mort, des blessures graves et/ou des dommages matériels :**



- Ne pas faire fonctionner le terminal ET 350 dans des conditions différentes de celles qui sont spécifiées.

**Pour réduire les risques d'incendie et d'explosion susceptibles, faute de précaution, de causer la mort, des blessures graves et/ou des dommages matériels :**

- Ne pas utiliser de produits de nettoyage inflammables ou combustibles sur le moniteur ou à proximité de celui-ci.

**Signification des étiquettes de sécurité**

Les symboles de sécurité suivants sont utilisés à l'intérieur et l'extérieur du moniteur ET 350:

Symbole	Signification
	<b>Attention</b> : référez-vous aux documents d'accompagnement
	<b>Mise en garde</b> : risque d'électrocution



# Informatie productveiligheid

## Voorgenomen gebruik

De 3M Dynapro™ ET 350 monitor (met name de modellen ET 350R, ET 350L2, en ET 350L3) dient als aanraakbeeldscherm wanneer deze is aangesloten op een hostcomputer in een industriële omgeving. De ET 350 monitor is niet bedoeld voor gebruik in gevaarlijke omgevingen.



## Waarschuwing

### Om het gevaar van persoonlijk letsel als gevolg van brand of explosies te beperken:

- Plaats dit apparaat niet in een gevaarlijke omgeving.
- Raadpleeg het veiligheidsinformatieblad van de reinigingsfabrikant bij het gebruik van ontvlambare of explosieve schoonmaakvloeistoffen in de nabijheid van de ET 350 monitor.

### Om het gevaar van ernstig of dodelijk persoonlijk letsel als gevolg van brand of elektrische schokken te beperken:

- Volg nauwkeurig de installatie-instructies van dit product en de eventuele accessoires.
- Alle onderhoudswerkzaamheden die niet beschreven worden in deze handleiding, moeten uitsluitend worden uitgevoerd door 3M Touch Systems onderhoudspersoneel.
- Voor de installatie van de ET 350R monitor in een omgeving met vervuilingsgraad 3: plaats de eenheid in een afgesloten gedeelte conform de NEMA 4X/IP66 standaard.
- Plaats de ET 350 monitor dichtbij de stroomtoevoer zodat de eenheid snel en gemakkelijk kan worden uitgezet. Voor permanente installaties moet er een gemakkelijk toegankelijke schakelaar in de vaste bedrading aanwezig zijn.
- Houd bij de installatie van de ET 350 monitor rekening met de omgeving (bijv. thermale en schok/vibratie factoren).
- Zorg voor een schone en betrouwbare aardleiding.
- Bij vaste bedradingsaansluitingen is een dubbele isolatiekabel vereist. Een schone en flexibele isolator (bijgeleverd) moet het gedeelte waar de kabel niet volledig dubbel is geïsoleerd bedekken wanneer deze wordt aangesloten op een verbindingsstrip connector.
- De montage van de bedrading moet worden gedaan door een erkende elektricien en voldoen aan de lokale en nationale voorschriften voor elektrische installaties.
- Gebruik bij het vervangen van een zekering of ander onderdeel de typen en classificaties zoals gespecificeerd door 3M Touch Systems.
- Plaats de ET 350R monitor in een afgesloten gedeelte volgens de NEMA 4X/IP66 standaard.
- Plaats de ET 350R monitor in een onbeschadigde en werkzame NEMA 4X/IP66 pakking.
- Gebruik een ET 350 monitor die niet voldoet aan de NEMA 4X/IP66 standaard niet in omgevingen die een NEMA 4X/IP66 afsluiting vereisen.
- Beschadig de ET 350 monitor pakking niet.



### Waarschuwing (vervolg)

#### **Om het gevaar van ernstig of dodelijk persoonlijk letsel als gevolg van elektrische schokken te beperken:**

- Maak de vermogensvoeding van de ET 350 monitor niet open. Deze bevat een gevaarlijk voltage. De vermogensvoeding bevat geen onderdelen die aanpassing of onderhoud vergen door gebruikers.
- Verzeker u ervan dat het voltage tussen de ET 350 monitor en de hostcomputer minder dan 2 Volt bedraagt.
- Zorg voor voldoende trekontlasting voor alle stroom- en communicatiekabels.
- Sluit de stroom af voordat u de ET 350 monitor van de ophanging loskoppelt.

#### **Om het gevaar van ernstig of dodelijk persoonlijk letsel als gevolg van elektrische of mechanische schokken te beperken:**

- Gebruik een "safe touch" instelling. Zeker wanneer er een applicatie op de monitor draait of in een opstelling waar veiligheid van essentieel belang is.
- Gebruik geen screensavers die niet door Windows wordt ondersteund: deze kunnen de "safe touch" instelling aantasten en het onwillekeurig starten of stoppen randapparatuur veroorzaken.
- Stel de "safe touch" op de juiste manier in: het aantal ingevoerde minuten voor de energiebesparing van het Windows besturingssysteem moet tenminste één minuut langer duren dan de screensaver van het Windows besturingssysteem.
- Zet het display power management system (DPMS) niet uit. Deze is te configureren in de instellingen van de monitor via het Utility menu.



### Voorzichtig

#### **Om het gevaar van klein of middelmatig letsel als gevolg van huidcontact of inslikking van reinigingsproducten te beperken:**

- Raadpleeg het veiligheidsinformatieblad van de reinigingsfabrikant en volg de instructies en adviezen.

#### **Om het gevaar van klein of middelmatig letsel of materiaalschade als gevolg van brand of elektrische schokken te beperken:**

- Wanneer de ET 350 monitor wordt gebruikt in corrosie vormende omgevingen, is het de verantwoordelijkheid van de gebruiker om de uitwerking van dit soort omgevingen op de monitor te testen en te evalueren. De monitor is na productie niet getest voor gebruik in corrosie vormende omgevingen en het gebruik van de monitor in zulke omgevingen kan leiden tot onveilige situaties.

#### **Om het gevaar van klein of middelmatig letsel als gevolg van spierverrekingen te beperken:**

- Vermijd het langdurig gebruik zonder pauze van de ET 350 monitor.

#### **Om het gevaar van klein of middelmatig letsel als gevolg van overbelasting van de ogen te beperken:**

- Vermijd het gebruik van de monitor op plaatsen waar omringend licht of geschitter in het beeldscherm weerkaatsen.

#### **Om het gevaar van klein of middelmatig letsel of materiaalschade als gevolg van milieuvuiling te beperken:**

- Verwerk, na gebruik, monitor conform de wettelijke milieuriichtlijnen.

 **Waarschuwing**

**Neem het volgende in acht om de risico's van elektrische schokken en/of brandwonden te reduceren die ernstig letsel, de dood en/of schade aan eigendommen tot gevolg kunnen hebben:**

- Maak de voedingsbron in de ET-eenheid niet open. Hierin is een gevaarlijke spanning/gevaarlijke energie aanwezig. In de voedingsbron bevinden zich geen onderdelen waaraan door de gebruiker onderhoud mag worden uitgevoerd of die door de gebruiker mogen worden afgesteld.
- Raak de connectors op de voedingsterminalstrip niet aan, tenzij de voeding is losgekoppeld.
- Raak blootliggende elektrische contacten in de ET-eenheid niet aan.

**Neem het volgende in acht om de risico's van elektrische schokken of brand te reduceren die, indien deze niet worden voorkomen, ernstig letsel, de dood en/of schade aan eigendommen tot gevolg kunnen hebben:**

- Als de ET-eenheid wordt gemonteerd en er wordt voor het paneel een NEMA 4X-pakking gebruikt, dient u de eenheid in een aangegeven (UL) behuizing aan te brengen.

**Neem het volgende in acht om de risico's van mechanische werking te reduceren die, indien deze niet worden voorkomen, schade aan eigendommen tot gevolg kunnen hebben:**



- Gebruik de ET 350-eenheid niet onder omstandigheden die buiten de bedrijfsspecificaties vallen.

**Neem het volgende in acht om de risico's van brand en explosies te reduceren die, indien deze niet worden voorkomen, ernstig letsel, de dood en/of schade aan eigendommen tot gevolg kunnen hebben:**

- Gebruik geen ontvlambare of brandbare reinigingsmiddelen voor of in de buurt van de monitor.

**Verklaringen van de veiligheidslabels**

Onderstaande veiligheidssymbolen worden gebruikt aan de buiten- en binnenkant van de ET 350 monitor:

Symbool	Betekenis
	<b>Pas op:</b> Raadpleeg de bijgeleverde documenten
	<b>Waarschuwing:</b> Gevaar op elektrische schokken



# Produktsicherheitshinweise

## Einsatzbereiche

Der Monitor 3M Dynapro™ ET 350 (insbesondere die Monitormodelle ET 350R, ET 350L2, und ET 350L3) bietet im Anschluss an einen Hauptrechner Kontaktbildschirmfunktionen für industrielle Anwendungsgebiete. Der Monitor ET 350 ist nicht für den Einsatz in Gefahrenzonen gedacht.



## Warnhinweise

**Maßnahmen zum Schutz vor Feuer- oder Explosionsgefahren, die zu schweren Verletzungen oder sogar zu Todesfällen führen können:**

- Produkt nicht in Gefahrenzonen installieren.
- Beim Einsatz von entzündlichen oder brennbaren Reinigungslösungen oder Flüssigkeiten in der Nähe oder am Monitor ET 350 die Angaben im Sicherheitsdatenblatt des Herstellers beachten und alle Anweisungen und Empfehlungen befolgen.

**Schutz vor Feuergefahr oder elektrischem Schlag, der zu schweren Körperverletzungen oder Tod führen kann:**

- Alle Montageanweisungen für das Produkt und Zubehör beachten.
- Wartungsarbeiten und andere nicht in diesem Handbuch beschriebene Prozeduren dürfen nur vom Servicepersonal von 3M Touch Systems ausgeführt werden.
- Bei der Montage eines Monitors ET 350R in einer Umgebung mit Verschmutzungsgrad 3 ist das Gerät in einem Schutzgehäuse zu installieren, das den Normvorschriften von NEMA 4X/IP66 entspricht.
- Installieren Sie den Monitor ET 350 in der Nähe eines Netzanschlusses, damit das Gerät einfach und schnell aus dem Netz genommen werden kann. Für Geräte mit dauerhaften elektrischen Anschlüssen ist ein gut zugänglicher Trennschalter in die elektrische Netzleitung einzubauen.
- Planen Sie beim Einbau des Monitors ET 350 die Betriebsumgebung ein (z. B. Wärmeunterschiede, Stoß - und Erschütterungsfaktoren).
- Sorgen Sie für saubere und zuverlässige Erdung.
- Beim Netzanschluss mit dauerhaftem Kabelanschluss der Monitortypen das Netzkabel doppelt isoliert sein. Ein durch-sichtiger und flexibler Isolator (mitgeliefert) muss beim Anschluss an die Klemmenleiste jeweils das nicht doppelt isolierte Kabelteil abdecken.
- Die elektrische Montage sollte nur von staatlich geprüften Elektrikern durchgeführt werden und hat allen Bundes- und Landesbaubestimmungen zu entsprechen.
- Beim Ersetzen von Sicherungen oder anderen Teilen sind grundsätzlich nur Teile einzusetzen, die dem von 3M Touch Systems angegebenen Typ und Nennwert entsprechen.
- Installieren Sie den Monitor ET 350R so, dass er den Umweltversiegelungsbestimmungen der Norm NEMA 4X/IP66 entspricht.
- Installieren Sie den Monitor ET 350R mit einer unbeschädigten und leistungsfähigen Dichtung gem. NEMA 4X/IP66.
- Monitore des Typs ET 350, die nicht für NEMA 4X/IP66 zugelassen sind, sollten nicht in Umfeldern eingesetzt werden, in denen eine Dichtung gemäß NEMA 4X/IP66 erforderlich ist.
- Die Monitordichtungen des ET 350 nicht beschädigen.



### Warnhinweise (Forts.)

#### **Maßnahmen zum Schutz vor elektrischem Schlag, der zu schwerer Körperverletzung oder Tod führen kann:**

- Die Netzteil des Monitors ET 350 nicht öffnen, da es unter gefährlicher Spannung steht. Das Netzteil enthält keine Teile oder Einstellmöglichkeiten, die von Benutzern gewartet werden können.
- Vergewissern Sie sich, dass der Spannungsunterschied zwischen dem Monitor ET 350 und dem Hauptrechner nicht mehr als 2 V beträgt.
- Achten Sie auf geeignete Zugentlastung der Fernmeldekabel und Netzkabel.
- Vor dem Entfernen des Monitors ET 350 vom Gestell Netzstecker ziehen.

#### **Schutz vor elektrischem Schlag oder mechanischem Aufprall, der zu schweren Körperverletzungen oder Tod führen könnte:**

- Stellen Sie eine "Sichere Berührung" ein, besonders wenn der Monitor mit einer Anwendung läuft oder in einer Umgebung aufgestellt ist, bei denen Sicherheitsbedenken bestehen.
- Benutzen Sie keinen Bildschirmschoner, der nicht zu einem Windows-Betriebssystem gehört, da dies die Einstellung "Sichere Berührung" beeinträchtigen könnte und im Gegenzug dazu führen könnte, das angeschlossene Peripheriegeräte ungewollt ein- oder ausgeschaltet werden.
- Stellen Sie die Berührungseinstellungen richtig ein. Die Anzahl der Minuten bis zum Einsetzen der Energiesparoption im Windows-Betriebssystem sollte mindestens eine Minute größer sein als die Zeit bis zum Einschalten des Bildschirmschoners im Windows-Betriebssystem.
- Stellen Sie das Stromzufuhrsystem für die Anzeige (DPMS), das aus dem Dienstprogramm-Menü konfiguriert wird, auf keinen Fall ab.



### Vorsicht

#### **Schutz vor geringfügigen oder leichten Verletzungen durch den Kontakt mit Reinigungslösungen oder -flüssigkeiten durch Einnahme oder Hautberührung:**

- Angaben im Sicherheitsdatenblatt des Herstellers beachten und alle Anweisungen und Empfehlungen befolgen.

#### **Schutz vor elektrischem Schlag oder Feuergefahr, die zu geringfügigen oder leichten Verletzungen oder Sachschäden führen könnte:**

- Sollte der Einsatz des Monitors ET 350 in zersetzenden Umfeldern geplant sein, ist der Benutzer dafür verantwortlich, die Eignung des Monitors für diese Umgebung zu überprüfen. Der Monitor wurde in der gelieferten Version nicht auf die Eignung für den Einsatz in zersetzenden Umfeldern geprüft. Der Einsatz in solchen Umfeldern ohne vorherige Prüfung kann zu mangelhaften Sicherheitsbedingungen führen.

#### **Schutz vor Muskelüberanstrengung, die zu geringfügigen oder leichten Verletzungen oder Sachschäden führen könnte:**

- Den Monitor ET 350 nicht für lange Zeit ohne Pause benutzen.

#### **Schutz vor Überanstrengung der Augen, die zu geringfügigen oder leichten Verletzungen oder Sachschäden führen könnte:**

- Monitor nur in Arbeitsumgebungen mit ausreichender Beleuchtung und mit Schutz vor Bildschirmreflexion einsetzen.

#### **Schutz vor Umweltgefahren, die zu geringfügigen oder leichten Verletzungen oder Sachschäden führen könnten:**

- Monitor gemäß allen einschlägigen behördlichen Bestimmungen entsorgen.





## Warnhinweise

**Maßnahmen zum Schutz vor Elektroschock- bzw. Verbrennungsrisiken, die zu schweren Unfällen mit Todes- oder Verletzungsfolge bzw. Sachschäden führen können:**

- Das Netzteil des ET-Monitors nicht öffnen, da es unter gefährlicher Stromspannung steht. Das Netzteil enthält keine Teile oder Einstellungsmöglichkeiten, die vom Benutzer erwartet werden können.
- Die Verbindungen auf der Klemmleiste nur berühren, wenn die Stromzufuhr unterbrochen ist.
- Vermeiden Sie freiliegende elektrische Kontakte innerhalb des ET-Monitors.

**Maßnahmen zum Schutz vor Elektroschock- und Feuerrisiken, die zu schweren Unfällen mit Todes- oder Verletzungsfolge bzw. Sachschäden führen können:**

- Wenn der ET-Monitor mit Hilfe einer Dichtung gem. NEMA 4X montiert wird, installieren Sie die Einheit in einem eingetragenen (UL) Gehäuse.

**Maßnahmen zum Schutz vor Risiken in Verbindung mit mechanischen Funktionen, die zu Sachschäden führen können:**



- Betreiben Sie den ET-Monitor nicht unter Bedingungen, die außerhalb der Betriebsspezifikationen liegen.

**Maßnahmen zum Schutz vor Feuer- und Explosionsrisiken, die zu schweren Unfällen mit Todes- oder Verletzungsfolge bzw. Sachschäden führen können:**

- Keine entzündlichen oder brennbaren Reinigungsmittel an oder in der Nähe des Monitors verwenden.

## Erklärung der Sicherheits-etiketten

Die folgenden Sicherheitssymbole sind auf der Außen- und Innenseite des Monitors ET 350 angebracht:

Symbol	Bedeutung
	<b>Warnung:</b> Bitte beiliegende Dokumentation beachten
	<b>Vorsicht:</b> Elektrische Schlaggefahr



# Informazioni per la sicurezza

## Applicazioni d'impiego del prodotto

Il monitor 3M Dynapro™ ET 350, in particolare i modelli ET 350R, ET 350L2 e ET 350L3, è destinato all'uso come monitor a schermo tattile in collegamento a un computer host in ambiente industriale. Il monitor ET 350 non è progettato per l'utilizzo in ambienti pericolosi.



## Avvertenza

### **Precauzioni per ridurre il rischio di incendi o esplosioni che potrebbero causare lesioni gravi o fatali:**

- Non installare o utilizzare il prodotto in ambienti pericolosi.
- Se si utilizzano prodotti liquidi infiammabili o combustibili per la pulizia del monitor ET 350 o nelle immediate vicinanze, consultare le istruzioni per la sicurezza e seguire attentamente tutte le istruzioni e raccomandazioni per l'uso di tali prodotti.

### **Precauzioni per ridurre il rischio di incendi o scosse elettriche che potrebbero causare lesioni gravi o fatali:**

- Seguire tutte le istruzioni per l'installazione del prodotto e dei suoi accessori.
- Per operazioni di manutenzione o altre procedure non descritte in questo manuale, rivolgersi solo a personale di assistenza 3M Touch Systems.
- Per il monitor ET 350R in ambiente di inquinamento Classe 3, installare l'unità in un contenitore sigillato secondo lo standard NEMA 4X/IP66.
- Installare il monitor ET 350 nei pressi di una presa di alimentazione elettrica, in modo tale che l'unità possa essere scollegata in modo semplice e rapido. Per i dispositivi collegati in modo permanente, installare un dispositivo di scollegamento di facile accesso e incorporato nei cavi di alimentazione.
- Progettare l'installazione del monitor ET 350 tenendo in considerazione l'ambiente di lavoro (per esempio, temperatura, urti o vibrazioni, ecc.).
- Installare una messa a terra sicura e affidabile.
- Quando si collega l'alimentazione elettrica per mezzo di cavi fissi, i cavi di alimentazione devono essere dotati di doppio isolamento. Il segmento di cavo utilizzato per il collegamento a un terminale a morsettiera deve essere dotato di un isolatore flessibile e trasparente (in dotazione) che deve coprire la porzione di cavo priva di doppio isolamento.
- I collegamenti devono essere effettuati da un elettricista qualificato e nel rispetto dei regolamenti nazionali e locali per la sicurezza elettrica.
- La sostituzione di fusibili o di altre parti deve essere effettuata utilizzando componenti del tipo indicato da 3M Touch Systems.
- Effettuare l'installazione del monitor ET 350R secondo le indicazioni di isolamento ambientale dello standard NEMA 4X/IP66.
- Installare correttamente il monitor ET 350R con una guarnizione NEMA 4X/IP66 integra ed in perfetta efficienza.
- Non utilizzare un monitor ET 350 non approvato NEMA 4X/IP66 in ambienti che richiedono l'isolamento NEMA 4X/IP66.
- Non danneggiare le guarnizioni del monitor ET 350.



### Avvertenza (segue...)

#### **Precauzioni per ridurre il rischio di scosse elettriche che potrebbero causare lesioni gravi o fatali:**

- Non aprire l'alimentatore del monitor ET 350. Esso contiene parti sotto tensione elevata. L'alimentatore non contiene parti che richiedono manutenzione o regolazione da parte degli utenti.
- Assicurare che la differenza di potenziale tra il monitor ET 350 e il computer host sia inferiore a 2V.
- Evitare di sottoporre i cavi per l'alimentazione e per i segnali a sforzi meccanici.
- Prima di rimuovere il monitor ET 350 dalla sua base, scollegare l'alimentazione elettrica.

#### **Precauzioni per ridurre il rischio di scosse elettriche o urti che potrebbero causare lesioni gravi o fatali:**

- Utilizzare l'impostazione "safe touch", in particolare se il monitor viene usato in applicazioni o ambienti in cui la sicurezza assume particolare importanza.
- Non utilizzare uno "screen saver" non Windows per non rischiare di alterare l'impostazione "safe touch" e di conseguenza causare l'avvio o l'arresto indesiderato di periferiche o macchinari collegati.
- Impostare la funzione "safe touch", con il numero di minuti per il risparmio energetico del sistema operativo Windows fissate impostate ad almeno un minuto oltre il tempo stabilito per l'entrata in funzione dello screen saver.
- Non disattivare il DPMS (Display Power Management System), configurabile dal menu Utility del monitor.



### Attenzione

#### **Precauzioni per ridurre il rischio di lesioni minori o non gravi che potrebbero derivare dal contatto con fluidi o soluzioni per la pulizia, tramite ingestione o contatto con la pelle:**

- Consultare le istruzioni per la sicurezza nell'uso dei materiali e seguire attentamente le istruzioni e i consigli del produttore.

#### **Precauzioni per ridurre il rischio di scossa elettrica o incendio con conseguenti lesioni minori o non gravi oppure danni materiali:**

- Se il monitor ET 350 viene utilizzato in ambienti corrosivi, è responsabilità dell'utente la verifica e la valutazione per l'utilizzo in tali ambienti. Il monitor, nelle condizioni standard di fornitura, non è approvato per l'utilizzo in ambienti corrosivi ed il suo utilizzo senza effettuare le necessarie verifiche e valutazioni potrebbe comportare condizioni d'uso non sicure.

#### **Precauzioni per ridurre il rischio di sforzi muscolari con conseguenti lesioni minori o non gravi oppure danni materiali:**

- Evitare l'utilizzo del monitor ET 350 per lunghi periodi di tempo senza pause.

#### **Precauzioni per ridurre il rischio di stanchezza oculare con conseguenti lesioni minori o non gravi oppure danni materiali:**

- Non utilizzare il monitor in ambienti troppo luminosi ed evitare i riflessi sullo schermo.

#### **Precauzioni per ridurre il rischio di inquinamento dell'ambiente che potrebbe causare lesioni minori o non gravi oppure danni materiali:**

- Effettuare lo smaltimento del monitor nel rispetto delle norme di legge.

 **Attenzione**

**Per limitare o prevenire il rischio di scosse elettriche e/o di ustioni che potrebbero provocare incidenti gravi o mortali e/o danni alle attrezzature, attenersi alle istruzioni riportate di seguito:**

- Non aprire l'alimentatore del monitor ET, poiché contiene componenti con una tensione e una potenza pericolose. L'alimentatore non contiene componenti interni la cui manutenzione o regolazione può essere eseguita dagli utenti.
- Toccare i connettori sulla morsettiera solo se il monitor è scollegato dalla rete.
- Non toccare i contatti elettrici non protetti all'interno del monitor ET.

**Per limitare o prevenire il rischio di scosse elettriche o di incendi che potrebbero provocare incidenti gravi o mortali nonché danni alle attrezzature, attenersi alle istruzioni riportate di seguito:**

- Se il monitor ET deve essere montato utilizzando una tenuta per pannelli di tipo NEMA 4X, installare l'unità in un alloggiamento di classe UL.

**Per limitare o prevenire i rischi connessi a funzioni meccaniche che potrebbero danneggiare le attrezzature, attenersi alle istruzioni riportate di seguito:**



- Utilizzare il monitor ET solo entro gli intervalli operativi indicati nelle specifiche.

**Per limitare i rischi di incendi e esplosioni che potrebbero provocare incidenti gravi o mortali e/o danni alle attrezzature, attenersi alle istruzioni riportate di seguito:**

- Non utilizzare detergenti infiammabili o combustibili per pulire il monitor o le aree circostanti.

**Illustrazione del significato dei simboli per la sicurezza**

I seguenti simboli per la sicurezza vengono utilizzati nelle parti esterne ed interne del monitor ET 350:

Simbolo	Significato
	<b>Attenzione:</b> Consultare la documentazione di accompagnamento
	<b>Attenzione:</b> Rischio di scossa elettrica



# Información de seguridad del producto

## Uso deseado

El monitor 3M Dynapro™ ET 350 (en particular, los modelos ET 350R, ET 350L2, y ET 350L3) está diseñado para proveer funciones de pantalla táctil cuando se lo conecte a una computadora central en un ambiente industrial. El monitor ET 350 no fue pensado para operar en ubicaciones peligrosas.



## Advertencia

### **Para reducir el riesgo de incendio o explosión que podría resultar en lesiones personales graves o muerte:**

- No instale o utilice este producto en ubicaciones peligrosas.
- Cuando utilice una solución o líquido de limpieza inflamable o combustible en el monitor ET 350 monitor o cerca del mismo, refiérase a las planillas de datos de seguridad del fabricante y siga todas las instrucciones y recomendaciones.

### **Para reducir el riesgo de incendio o choque eléctrico, que podría resultar en lesiones personales severas o muerte:**

- Siga todas las instrucciones de instalación del producto y sus accesorios.
- Todo procedimiento de mantenimiento no descrito en este manual deberá ser realizado, exclusivamente, por el personal de mantenimiento de 3M Touch Systems.
- Con respecto al monitor ET 350R a ubicar en un ambiente con una contaminación grado 3, instale la unidad en un gabinete aprobado según el estándar NEMA 4X/IP66.
- Instale el monitor ET 350 cerca de la fuente de alimentación, a fin de que la unidad pueda ser fácil y rápidamente desconectada. Para el equipo conectado de manera permanente, habrá que incorporar al cableado fijo un dispositivo de desconexión de rápido acceso.
- Prepare la instalación del monitor ET 350 tomando en cuenta el ambiente operativo (por ejemplo, factores térmicos, choque/vibración, etc.).
- Provea una base limpia y confiable.
- Cuando conecte la alimentación con cables de campo fijo, el cable de alimentación deberá tener aislación doble. El aislante transparente y flexible (que se provee con el equipo) debe cubrir la porción del cable que no tiene aislación doble cuando se lo conecta al conector de regletas terminales.
- La instalación del cableado debe ser realizada por un electricista calificado y cumplir con los códigos eléctricos locales y federales.
- Cuando reemplace un fusible u otro repuesto, use un repuesto del tipo y clasificación especificados por 3M Touch Systems.
- Instale el monitor ET 350 R como corresponda, a fin de que quede sellado desde el punto de vista del ambiente, tal cual lo dispone el estándar NEMA 4X/IP66.
- Instale el monitor ET 350R con una junta NEMA 4X/IP66 que esté intacta y efectiva.
- No utilice un monitor ET 350 que no esté calificado para NEMA 4X/IP66 en ambientes que requieran un sello NEMA 4X/IP66.
- No dañe ninguna de las juntas del monitor ET 350.



### Advertencia (continuación)

**Para reducir el riesgo de choque eléctrico que podría resultar en lesiones personales severas o muerte:**

- No abra la fuente de alimentación del monitor ET 350. Contiene tensiones peligrosas. La fuente de alimentación no cuenta en su interior con partes o ajustes atendibles por el usuario.
- Asegúrese que la diferencia de potencial de masa entre el monitor ET 350 y la computadora central sea menor de 2V.
- Provea un alivio adecuado de la tensión para todos los cables de comunicaciones y alimentación.
- Antes de retirar al monitor ET 350 de su instalación, desconecte la alimentación de la unidad.

**Para reducir el riesgo de choque eléctrico o impacto mecánico que podrían resultar en lesiones personales severas o muerte:**

- Aplique una configuración de "contacto seguro", especialmente si el monitor está ejecutando una aplicación o si se encuentra en una configuración que puede afectar la seguridad.
- No utilice un protector de pantalla que no pertenezca al sistema operativo Windows que pueda afectar la configuración de "contacto seguro" y a su vez, podría provocar el arranque o interrupción inadvertida del equipo periférico conectado.
- Configure el contacto seguro como corresponda, debiendo ser el número de minutos ingresado para el ahorrador de energía del sistema operativo Windows, mayor en un minuto, por lo menos, al tiempo ingresado para el protector de pantalla de Windows.
- No desconecte el sistema de gestión de energía (DPMS) del monitor, configurable desde el menú Utility (Utilitarios) visualizado en la pantalla.



### Precaución

**Para reducir el riesgo de lesiones leves o moderadas por el contacto con soluciones o líquidos de limpieza, por la ingestión o contacto con la piel:**

- Refiérase a los datos de seguridad del fabricante del limpiador y siga todas las instrucciones y recomendaciones.

**Para reducir el riesgo de choque eléctrico o incendio que puede resultar en lesiones leves o moderadas o provocar daño a la propiedad:**

- Si se utilizará al monitor ET 350 en un ambiente propenso a la corrosión, el usuario será responsable de probar y evaluar al monitor en dichos ambientes. El monitor, empaquetado y enviado, no fue evaluado para ser usado en ambientes corrosivos y su uso en dichos ambientes, sin una correcta prueba y evaluación, puede llevara situaciones de riesgo.

**Para reducir el riesgo de tensión muscular que puede resultar en lesiones leves o moderadas o provocar daño a la propiedad:**

- Evite utilizar el monitor ET 350 por períodos prolongados sin interrupción.

**Para reducir el riesgo de tensión ocular que puede resultar en lesiones leves o moderadas o provocar daño a la propiedad:**

- Utilice el monitor en sitios que no impongan demasiada luz natural o reflejo sobre la pantalla.

**Para reducir el riesgo de contaminación ambiental que puede resultar en lesiones leves o moderadas o provocar daño a la propiedad:**

- Disponga del monitor de acuerdo con las regulaciones gubernamentales válidas en su zona.



 **Advertencia**

**Para disminuir los riesgos relacionados con descargas eléctricas y quemaduras, los cuales, si no se evitan, pueden ocasionar la muerte, lesiones graves o daño a la propiedad:**

- No abra la unidad de suministro de energía de la unidad ET, pues contiene energía o voltaje peligroso. La unidad de suministro de energía no contiene piezas a las que pueda dar servicio ni ajustar el usuario.
- Evite el contacto con conectores en las regletas de las terminales de energía a menos que la energía esté desconectada.
- Evite contactos eléctricos expuestos dentro de la unidad ET.

**Para disminuir los riesgos relacionados con descargas eléctricas e incendios, los cuales, si no se evitan, pueden ocasionar la muerte, lesiones graves o daño a la propiedad:**

- Si la unidad ET está montada utilizando un empaque de panel NEMA 4X, instale la unidad en un lugar certificado (UL).

**Para disminuir los riesgos relacionados con el funcionamiento mecánico, los cuales, si no se evitan, pueden ocasionar daño a la propiedad:**



- No haga funcionar la unidad ET en condiciones que se salgan de las especificaciones de uso.

**Para disminuir los riesgos relacionados con incendios y explosiones, los cuales, si no se evitan, pueden ocasionar la muerte, lesiones graves o daño a la propiedad:**

- No utilice limpiadores inflamables o combustibles en el monitor o cerca de éste.

**Explicación de los rótulos de seguridad**

Los siguientes símbolos de seguridad se utilizan en el interior y el exterior del monitor ET 350:

<b>Símbolo</b>	<b>Significado</b>
	<b>Atención:</b> Refiérase a la documentación adjunta.
	<b>Precaución:</b> Peligro de choque eléctrico.



# 产品安全信息

## 设计用途

3M Dynapro™ ET 350 显示器（具体型号为 ET350R、ET 350L2 和 ET350L3）与主机连接，按照工业要求设置后，可用作触摸屏。ET350 显示器不可用于危险场所。



### 为了减少因火灾或爆炸而造成严重的人身伤害或死亡的危险：

- 请勿在危险场所安装或使用本产品。
- 当使用易燃性、可燃性清洗液或液体，擦拭或接近 ET350 显示器时，请参阅制造商的材料安全数据单，并遵从所有的说明和建议。

### 为了减少因火灾或电击而造成严重的人身伤害或死亡的危险：

- 请遵从所有产品和配件的安装说明。
- 任何维修工作或其他在本指南中没有说明的操作只能由 3M Touch Systems（3M 触摸系统）维修人员进行。
- 在污染度 (Pollution Degree) 为 3 的环境下，ET 350R 显示器应安装在达到 NEMA 4X/IP66 标准的密封外壳中。
- ET 350 显示器应安装在接近电源插座的地方，从而可以方便而快速地切断电源。若要将设备与电源永久性地连接，则在配线时必须安装一个便于操作的开关装置。
- 安装 ET 350 显示器时应考虑操作环境（如热、震动 / 摆动因素）。
- 应提供完全、可靠的接地。
- 对于 ET 350L3 显示器和 ET 350R 显示器，如果通过固定的现场连线与电源连接时，则电源线必须是双层绝缘的。对于在连接到接线板插孔时出现的没有双层绝缘的电缆部分，必须用干净、柔韧的绝缘带（已提供）将其缠住。
- 配线装置必须由得到许可的熟练电工来完成，且必须符合联邦和当地的电气法规。
- 替换保险丝或其他零件时，应采用 3M Touch Systems（3M 触摸系统）指定的类型和等级。
- 应按照环境密封的 NEMA4X/ IP66 标准，正确安装 ET 350R 显示器。
- 使用完好而有效的 NEMA 4X/IP66 垫圈，正确安装 ET 350R 显示器。
- 在需要达到 NEMA 4X/IP66 密封标准的环境下，请勿使用未标定为达到 NEMA 4X/IP66 密封标准的 ET 350 显示器。
- 请勿损坏任何 ET 350 显示器的垫圈。

 **警告 (续)**

**为了减少因电击而造成严重的人身伤害或死亡的危险:**

- 请勿打开 ET 350 显示器中的电源。它带有很高的危险电压。电源中没有需要用户维修或调节的零件。
- 确保 ET 350 显示器和主机之间的接地电位差小于 2V。
- 确保所有通信连线和电源线留有适当的长度余量。
- 在将 ET 350 显示器从装配架上移开前，请切断其电源。

**为了减少因电击或机械碰撞而造成严重的人身伤害或死亡的危险:**

- 尤其是该显示器正在运行某个应用程序，或对于某个设置应特别注意安全时，应用“安全触摸”设置。
- 请勿使用非 Windows 操作系统的屏幕保护程序，这样可能会影响“安全触摸”设置，从而导致与其连接的外围设备出现异常打开或关闭现象。
- 正确设定安全触摸设置，使输入 Windows 操作系统节能程序的时间比输入 Windows 操作系统屏幕保护程序的时间至少多 1 分钟。
- 请勿关闭显示器的电源管理系统 (DPMS)，该电源管理系统可从显示器屏幕上的“Utility (实用程序)”菜单中进行配置。

**减小电击和/或灼伤危险，否则可能造成死亡或严重伤害和/或财产损失:**

- 切勿打开 ET 装置中的电源。其中带有危险性电压/危险性能量。电源内部没有使用者可维修的零部件或调节。
- 避免接触电源端子带上的连接器，除非已断开电源。
- 避免接触 ET 装置内部的裸露电气部件。

**减小电击或失火危险，若不加以防范，会造成死亡或严重伤害和/或财产损失:**

- 果是使用 NEMA 4X 面板衬垫安装 ET 装置，则在列出的 (UL) 殼罩內安裝該裝置。

**减小机械功能危险，若不加以防范，可能導致財產損失:**

- 切勿在操作規範之外的條件下操作 ET 裝置。

**减小失火和爆炸的危险，若不加以防范，可能造成死亡或严重伤害和/或财产损失:**

- 在監視器上或附近切勿使用可燃或易燃清潔器。

 **小心**

**为了减少通过诸如吸入和皮肤接触的方式，与清洗液或液体接触而造成轻度或中度伤害的危险:**

- 请参阅清洁剂制造商的材料安全数据单，并遵从所有的说明和建议。

**为了减少因电击或火灾而造成轻度或中度伤害，或财产损失的危险:**

- 如果 ET 350 显示器将用于腐蚀性的环境中，使用者有责任在该环境下对显示器进行测试和评估。该显示器在出厂前没有在腐蚀性的环境中做过评估，在该环境下，如果没有进行评估和测试，可能会导致危险情形。

**为了减少因肌肉损伤而造成轻度或中度伤害，或财产损失的危险:**

- 避免长时间不间断地使用 ET 350 显示器。

**为了减少因眼睛疲劳而造成轻度或中度伤害，或财产损失的危险:**



- 不能在太亮的环境中使用显示器，且屏幕不能太耀眼。

**为了减少因环境污染而造成轻度或中度伤害，或财产损失的危险:**

- 按照适用的政府规章来处理显示器。

## 安全标签说明

ET 350 显示器的内部和外部使用下列安全符号：

符号	含义
	<b>注意：</b> 请参阅随附文档
	<b>小心：</b> 电击危险



# Contents

<b>Before you start</b>	<b>About the User's Installation Guide.....</b>	<b>1</b>
	Topics .....	1
	Warnings and cautions .....	1
	Related documents .....	1
	Terms .....	2
	Product support .....	3
	Contacting 3M Touch Systems .....	3
<b>Chapter 1</b>	<b>Introducing the ET 350 monitor.....</b>	<b>5</b>
	Packing lists.....	5
	Standard features .....	6
	Distinctive features of each model .....	8
	Options .....	10
	Mounting kits .....	11
<b>Chapter 2</b>	<b>Installing the monitor .....</b>	<b>13</b>
	Installation summary .....	13
	Before installing .....	14
	Step 1: Connect video (VGA) signal cable .....	14
	Step 2: Connect serial cable .....	15
	Step 3: Connect to power supply.....	16
	Step 4: Adjust display settings .....	19
	Step 5: Install software and import TouchSurround files .....	22
	Step 6: Set "backlights saver" and "safe touch" .....	25
	Step 7: Close enclosure and hatch.....	28
	Step 8: Mount monitor .....	28
<b>Chapter 3</b>	<b>Maintaining the monitor .....</b>	<b>31</b>
	Cleaning .....	31
	Replacing backlights .....	32
	Replacing the fuse .....	32
	Checking gaskets.....	33
	Maintaining the ET 350 monitor with Moisture Deflector .....	34
<b>Chapter 4</b>	<b>TouchSurround and graphic underlay .....</b>	<b>35</b>
	About the TouchSurround.....	35
	Replacing a TouchSurround graphic underlay .....	37
<b>Chapter 5</b>	<b>Troubleshooting .....</b>	<b>45</b>
	General problems .....	45
	Touch screen driver error messages .....	47
<b>Appendix A</b>	<b>Specifications .....</b>	<b>49</b>
<b>Appendix B</b>	<b>Installing monitor with KVM extender .....</b>	<b>57</b>
<b>Appendix C</b>	<b>Connector pin-outs.....</b>	<b>63</b>





# List of Figures

Figure 1: 3M Dynapro ET 350 monitor .....	6
Figure 2: NEMA 4X panel gasket (comes with ET 350R) .....	8
Figure 3: NEMA 4X hatch and extended cover (comes with ET 350L3) .....	9
Figure 4: Moisture Deflector option.....	11
Figure 5: Connectors: ET 350 monitor (without KVM extender) .....	14
Figure 6: Connecting AC power cable wires to connectors.....	17
Figure 7: Terminal connection for AC power (ET 350R, ET 350L3 monitors) and for DC power.....	18
Figure 8: Connecting DC power cable wires to connectors.....	19
Figure 9: PC menu options.....	20
Figure 10: Auto display setup .....	21
Figure 11: Loosening fuse holder.....	32
Figure 12: Removing fuse from fuse holder .....	33
Figure 13: Location of optional security screws .....	38
Figure 14: Disconnecting touch screen tail connector .....	39
Figure 15: Removing display panel nuts and washers .....	40
Figure 16: Sliding display pan out and lifting it.....	41
Figure 17: Removing original underlay .....	42
Figure 18: Placing new underlay.....	43
Figure 19: Reconnecting touch screen tail .....	44
Figure 20: Enclosure dimensions .....	49
Figure 21: Cutout dimensions .....	50
Figure 22: Enclosure of ET 350 monitor with KVM extender .....	57
Figure 23: Connectors: ET 350 monitor with KVM extender .....	61



## BEFORE YOU START

# About the User's Installation Guide

### Topics

This manual is written for system integrators and day-to-day users of the 3M Dynapro™ ET 350 monitor. The manual covers the following topics:

- Installing communication and power cables
- Installing the touch screen software
- Adjusting display settings
- Mounting the monitor
- Maintaining and cleaning the monitor
- Customizing and replacing a TouchSurround™ graphic underlay

### Warnings and cautions

For a list of all warnings and cautions that appear in this manual, see “Product safety information”, starting on page i.

For information on the safety symbols used on the interior and exterior of the monitor, see “Explanation of safety labels” on page iii.

### Related documents

#### **Mounting instructions for ET 350R and ET 350L3 monitors**

If you ordered either the ET350R monitor or the ET 350L3 monitor, one of these installation instruction documents will ship with this manual and your monitor (and are also available for download from the 3M Touch Systems web site: [www.3Mtouch.com](http://www.3Mtouch.com)):

- *Installing the NEMA 4X Panel Gasket* (comes with ET 350R monitor)
- *Installing the NEMA 4X Hatch* (comes with ET 350L3 monitor)

For more information on ET 350 monitor models, see “Distinctive features of each model” on page 8.

#### **Instructions for optional mounting kits**

For information on optional mounting kits and the installation instructions that accompany those kits, see “Optional mounting kits” on page 28.

## Software guides

The ET 350 monitor User's Installation Guide explains how to install touch screen software that will run with operating systems supported by the ET 350 (see Chapter 2).

For information on how to *customize* the software, refer to one of the following manuals. Both of these software guides may be downloaded from the 3M Touch Systems web site ([www.3Mtouch.com](http://www.3Mtouch.com)).

- For Windows XP Professional and Windows 2000 Professional operating systems, refer to: *MicroTouch NFI Software Guide for Windows XP and Windows 2000*.
- For Windows NT 4.0 and Windows 9X operating systems, refer to: *Configuration Utilities User's Guide*.

## README files

On the floppy disks that came with your ET 350 monitor, there are README files with driver installation instructions and other driver information.

## Terms

This term	Refers to
ACPI	Advanced Configuration and Power Interface. A power management feature that is configurable in Windows operating systems.
Bezel*	The front rim of the unit that contains the touch screen and the TouchSurround.
Display area*	The part of the touch screen that is positioned over the display of the monitor. Touches in the display area emulate the movements and actions of a mouse.
DPMS	Display power management system. Some ET units allow this energy saving setting to be changed. For ET 35X monitor models <i>without a heater</i> , the DPMS should not be turned off. For DPMS instructions for ET 35X monitor models <i>with a heater</i> , refer to instructions that ship with models with heaters.
Graphic underlay (also called TouchSurround underlay)	A graphic that illustrates the TouchSurround and fits behind the touch screen. 3M Dynapro industrial products may be ordered with standard or custom underlays. Buttons and controls for the standard underlays are pre-defined; you must define buttons and controls for custom underlays.
KVM extender	An optional feature of the ET 350 monitor that allows the monitor to be located as much as 1000 feet (300 meters) from the host computer.
MicroTouch™ Near Field Imaging™ (NFI) touch screen	A touch screen that uses a proprietary imaging technique to generate a precise profile of a touch from voltage changes in the electrostatic field close to the point of contact.
Touch screen	The front surface of the ET 350 monitor, comprising the display area and the TouchSurround.
TouchSurround*	The area on the front of the touch screen, not including the display area. With the TouchSurround, part of the touch screen can be used to define keys (such as keyboard keys).

---

\*For illustration identifying this item, see Figure 1, page 6

## Product support

### Registration

Register your 3M Dynapro ET 350 monitor by mailing the postage-paid Product Registration Card. It detaches from the Warranty Card that came with your unit. The Product Registration Card may also be faxed to 3M Touch Systems (604-521-4629).

### Returning products

All returned 3M Dynapro industrial products must be accompanied by a Service Return Authorization (SRA) number. For details, contact 3M Touch Systems customer service.

## Contacting 3M Touch Systems

For general information, service, and technical support for 3M Dynapro industrial products, use the contact information below:

Area	Type of service	Contact information
<b>USA and Canada</b>	General information	<b>Tel</b> 800-667-0374 (toll free)* <b>Fax</b> 604-521-4629 <b>E-mail</b> etsales@mmm.com <b>Web site</b> <a href="http://www.3Mtouch.com">www.3Mtouch.com</a>
	Customer service	<b>Tel</b> 800-667-0374 (toll free)* <b>Fax</b> 604-521-4629 <b>E-mail</b> 3MTScustomerservice@mmm.com
	Technical support	<b>Tel</b> 800-667-0374 (toll free)* <b>Fax</b> 604-521-4629 <b>E-mail</b> 3Mdynaprotechsupport@mmm.com
<b>Outside USA and Canada</b>	General information	<b>Tel</b> 604-521-3962* <b>Fax</b> 604-521-4629 <b>E-mail</b> etsales@mmm.com
	Customer service	<b>Tel</b> 800-667-0374* <b>Fax</b> 604-521-4629 <b>E-mail</b> 3MTScustomerservice@mmm.com
	Technical support	<b>Tel</b> 604-521-3962* <b>Fax</b> 604-521-4629 <b>E-mail</b> 3Mdynaprotechsupport@mmm.com

\*Call between 7:30 a.m. and 5:00 p.m., Pacific Time



## CHAPTER 1

# Introducing the ET 350 monitor

### About the chapter

This chapter provides the following information:

- Basic and model-specific packing lists for the ET 350 monitor
- Standard features of the ET 350 monitor
- Distinctive features of each ET 350 monitor model
- Options for the ET 350 monitor

### Packing lists

#### The basics

The ET 350 monitor will arrive with the following items. Inspect the monitor for shipping damage and verify the contents of the box against this list:

- 3M Dynapro ET 350 monitor.
- Floppy disks with MicroTouch NFI touch screen software and README files for Windows NT 4.0, Windows 9X and Windows XP/2000 operating systems.
- Allen key (5/32-inch).
- Full-scale cutout template.
- Warranty card with detachable mail-in Product Registration Card.
- 3M Dynapro *ET 350 Monitor User's Installation Guide* (this manual).

#### Model-specific packing lists

In addition to the standard items listed above, each of the three ET 350 monitor models will come with different materials (for information on the distinctive features of each model, see “Distinctive features of each model” on page 8):

##### **ET 350R monitor (panel gasket)**

- NEMA 4X panel gasket
- Power cable
- Screws and washers
- Instructions for installing the NEMA 4X panel gasket

##### **ET 350L2 monitor (neither panel gasket nor hatch)**

- Power cable

### ET 350L3 monitor (hatch)

- NEMA 4X hatch and extended hatch cover
- NEMA 4X hatch gasket
- Cable fitting components
- Screws
- Clear, flexible insulator
- Instructions for installing the NEMA 4X hatch

The packing list for the KVM extender option appears on page 10.

## Standard features

The ET 350 monitor is an industrial flat-panel monitor with an integrated MicroTouch NFI touch screen with TouchSurround. The monitor is designed for rugged use in demanding industrial applications. The standard features of the ET 350 monitor are described below.

### Display

The display is an Active Color 15-inch Thin Film Transistor (TFT), Liquid-Crystal Display (LCD) and is capable of 1024 × 768 XGA resolution and up to 16.7M (million) colors.

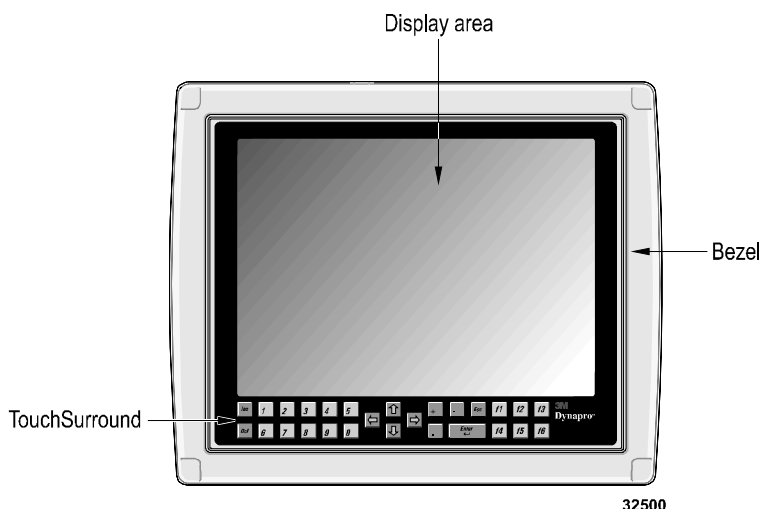

Figure 1: 3M Dynapro ET 350 monitor

### Touch screen

The monitor's MicroTouch NFI touch screen consists of a chemically strengthened glass surface with a controller that measures disturbances in an electrostatic field near the surface of the screen.



The touch screen consists of the display area and the TouchSurround (Figure 1). Touches in the display area emulate the movements and actions of a mouse, and you can use your finger like a pointer. The TouchSurround can emulate keys on a keyboard.

The MicroTouch NFI touch screen provides highly accurate and clear optics, is extremely durable, and can be operated accurately with gloves. The touch screen does not require realignment to maintain touch accuracy, even with variations in temperature and humidity.

## **Software**

Touch screen drivers for the ET 350 monitor are included on the floppy disks that came with the monitor. The software supports:

- Windows XP Professional operating system
- Windows 2000 Professional operating system
- Windows NT 4.0 operating system
- Windows 98 and Windows 95 (Windows 9X) operating systems

For details on installing the touch screen drivers and utilities, see “Step 5: Install software and import TouchSurround files” starting on page 22.

## **Backlights**

The life expectancy of the backlights is about 35,000 hours.

If the host computer is running Windows XP, 2000, or 98 operating systems, you can extend the life of the monitor’s backlights by using the operating system’s energy saver. For details, see “Backlights saver” on page 25.

For information on replacing the backlights, contact 3M Touch Systems customer service (see “Contacting 3M Touch Systems” on page 3).

## Distinctive features of each model

All ET 350 monitor units have the standard features described above. The distinctive features of each model are described below and summarized in Table A.

### ET 350R monitor (NEMA 4X panel gasket)

The ET 350R monitor has a UL Recognized component mark. It comes with a gasket that mounts between the monitor and a wall or panel (Figure 2).

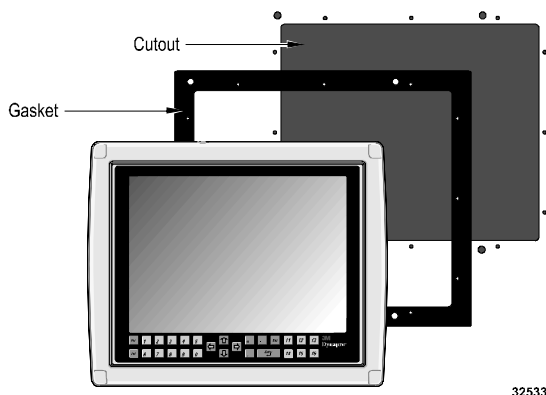

Figure 2: NEMA 4X panel gasket (comes with ET 350R)

The ET 350R monitor is suitable for Pollution Degree 3 environments if installed and tested with the panel gasket in an enclosure that meets NEMA 4X/IP66 ratings. If the ET 350R monitor is not mounted in such an enclosure or mounted without the gasket, the unit is suitable for Pollution Degree 2 environments.

### ET 350L2 monitor (no gasket or hatch)

The ET 350L2 monitor comes with neither a gasket nor a hatch. This model is UL Listed for Pollution Degree 2 environments and can perform as a stand-alone unit in a Pollution Degree 2 environment.

### ET 350L3 (NEMA 4X hatch)

The ET 350L3 monitor comes with a NEMA 4X hatch (and extended hatch cover) to seal both communication and power connections (Figure 3).

When properly installed with the materials supplied, the hatch provides a NEMA 4X/IP66 seal on all sides and the monitor is UL Listed for Pollution Degree 3 environments.

The ET 350L3 monitor may be used as a stand-alone unit in Pollution Degree 3 environments.

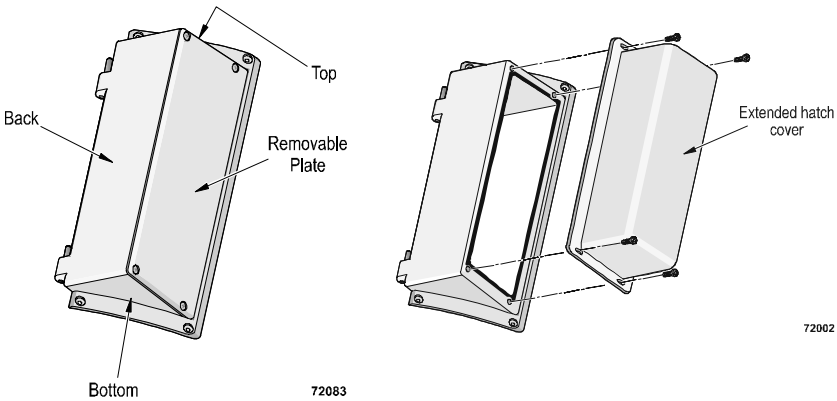

Figure 3: NEMA 4X hatch and extended cover (comes with ET 350L3)

Table A: Summary of features of each ET 350 model

Model	Distinctive features
<p><b>ET 350R</b></p> <p>This model comes with:</p> <ul style="list-style-type: none"> <li>• Panel gasket</li> <li>• Screws and washers</li> <li>• Power cable</li> <li>• Installation instructions</li> </ul> <p><b>Note:</b> On-site inspection is required to verify pollution degree suitability of the ET 350R and that the installation complies with federal and local electrical codes.</p>	<ul style="list-style-type: none"> <li>• UL Recognized component mark.</li> <li>• NEMA 4X/IP66 rating for a panel mount application.</li> <li>• Monitor suitable for Pollution Degree 3 environments if installed and tested with panel gasket in an enclosure that meets NEMA 4X/IP66 rating.</li> <li>• Suitable for Pollution Degree 2 environments if not mounted or if mounted without the supplied gasket.</li> </ul>
<p><b>ET 350L2</b></p> <p>This model comes with:</p> <ul style="list-style-type: none"> <li>• Power cable</li> </ul> <p>This model does <i>not</i> come with gasket or hatch.</p> <p>(No on-site inspection required).</p>	<ul style="list-style-type: none"> <li>• UL Listing mark for Pollution Degree 2 environments.</li> <li>• Monitor can perform as a stand-alone unit in a Pollution Degree 2 environment</li> </ul>
<p><b>ET 350L3</b></p> <p>This model comes with:</p> <ul style="list-style-type: none"> <li>• NEMA 4X hatch (and extended hatch cover)</li> <li>• Screws and fitting components</li> <li>• Installation instructions</li> </ul> <p>(No on-site inspection required).</p>	<ul style="list-style-type: none"> <li>• UL Listing mark for Pollution Degree 3 environments</li> <li>• NEMA 4X/IP66 rating</li> <li>• Monitor can perform as a stand-alone unit in a Pollution Degree 3 environment.</li> </ul>

**Note:** IEC and stripped power cables are available from 3M Touch Systems for both North American and European applications. For more information on power cables, see “Step 3: Connect to power supply” in Chapter 2, page 16.

## Options

There are three types of options that may be ordered for the ET 350 monitor (not including mounting options, which are discussed on page 11):

- Keyboard, video, and mouse (KVM) extender (single or dual) option
- Fixed field wiring
- The 3M Dynapro Moisture Deflector

Table B summarizes the options that are available for the ET 350 monitor models.

**Table B: Options available for ET 350 monitor models**

Monitor Model	KVM extender (single)	KVM extender (dual)	Field wiring	Moisture deflector
ET 350R	Option	Option	Option	Option
ET 350L2	Option	Option	n/a	Option
ET 350L3	Option	Option	Standard	Option

### KVM extender (single or dual) option

The ET 350 monitor may come with a keyboard, video, and mouse (KVM) extender option that allows the monitor to be located as much as 1000 feet (300 meters) from the host computer.

#### Packing list for KVM extender option

If you ordered the ET 350 monitor with the KVM extender option, your package should include:

- KVM local device
- KVM remote device (built into the housing of the ET 350 monitor)
- Serial cable
- Combination keyboard, video, and mouse cable to connect the local unit to the host computer
- KVM extender manufacturer's manual

For more information on the KVM extender, see installation instructions in Appendix B.

### Fixed field wiring

Fixed field wiring is an option for the model that comes with a NEMA 4X panel gasket (ET 350R monitor) and is standard for the model that comes with a NEMA 4X hatch (ET 350L3 monitor). Fixed field wiring is not available for the ET 350L2 monitor.

For more information on field wiring, see "AC power supply with fixed field wiring (ET 350R monitor and ET 350L3 monitor only)" on page 17.

## Moisture Deflector

The Moisture Deflector is a durable plastic component that surrounds the touch screen display of the monitor and offers protection to the monitor from moisture that might collect on the unit.

The Moisture Deflector option can be supplied only when ordering an ET 350 monitor. It cannot be added to the monitor later.

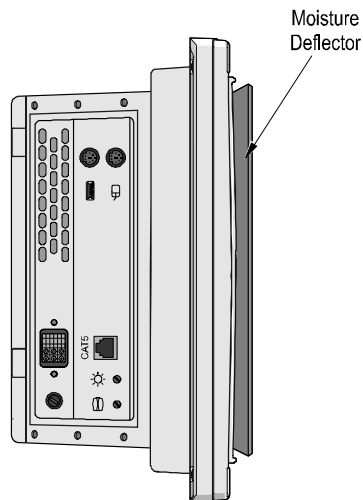

32532

**Figure 4: Moisture Deflector option**

For guidelines on mounting the ET 350 monitor with Moisture Deflector, see page 29. For information on handling and maintaining the ET 350 monitor with Moisture Deflector, see page 34.

## Mounting kits

Two of the three ET 350 monitor models come with their own mounting/sealing equipment:

- ET 350R monitor comes with a NEMA 4X panel gasket
- ET 350L3 monitor comes with a NEMA 4X hatch

The ET 350L2 monitor does not come with mounting/sealing materials.

There are three optional mounting kits available from 3M Touch Systems for use with the ET 350 monitor. Each kit comes with its own set of instructions for mounting and sealing the unit:

- Boom mount kit
- Rack mount kit
- Desktop kit

Table C summarizes the mounting possibilities for each of the ET 350 monitor models.

**Table C: Mounting possibilities for ET 350 monitor models**

<b>Monitor Model</b>	<b>NEMA hatch</b>	<b>NEMA panel</b>	<b>Desktop stand</b>	<b>Rack mount</b>	<b>Boom mount</b>
<b>ET 350R</b>	Option	Standard	Option	Option	Option
<b>ET 350L2</b>	n/a	n/a	Option	n/a	n/a
<b>ET 350L3</b>	Standard	n/a	Option	n/a	n/a

For more information about the mounting kits, see “Step 8: Mount monitor” on page 28.

## CHAPTER 2

# Installing the monitor

### About the chapter

This chapter provides pre-installation recommendations and step-by-step instructions for installing the ET 350 monitor.

### Installation summary

These steps outline a typical installation procedure for the ET 350 monitor. While most installations will follow these steps, your specific installation may differ.

Here is a summary of the steps for installing the ET 350 monitor:

1. Connect video signal cable
2. Connect serial cable

---

#### Important

If your ET 350 monitor includes a KVM extender option, follow the steps in Appendix B and then complete the remaining steps in this chapter.

---

3. Connect to power supply
4. Adjust display settings
5. Install touch screen software and import TouchSurround files
6. Set backlights saver and safe touch
7. Close enclosure and (if applicable) close hatch
8. Mount monitor

---

#### Warning

To reduce the risk of fire or electric shock which could result in serious personal injury or death:

- Install the ET 350 monitor close to the power source so the unit can be easily and quickly disconnected. For permanently connected equipment, a readily accessible disconnect device must be incorporated in the fixed wiring.
  - Any servicing or other procedures not described in this manual are to be performed only by 3M Touch Systems service personnel.
-

## Before installing

Before beginning to install the ET 350 monitor, consider the following recommendations:

- **Get the latest video driver** for your host computer's video adapter card. To find out if your driver is the most current one, check the web site of the video adapter's manufacturer.
- **Check the host computer's monitor settings** to make sure that the resolution is not greater than 1024 x 768.

## Step 1: Connect video (VGA) signal cable

The video (VGA) signal cable carries a video signal from the computer's video adapter to the monitor. The ET 350 monitor comes with a standard 15-pin VGA cable that plugs into the monitor's female connector. The standard cable length is 6 feet. There are 25-foot and 50-foot cable options available.

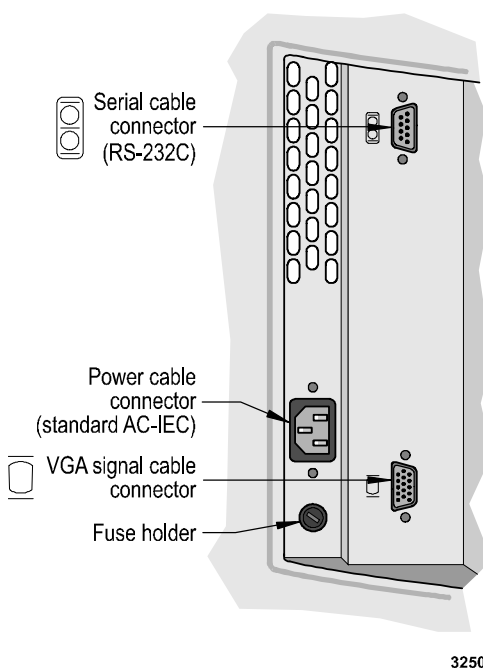

32501

**Figure 5: Connectors: ET 350 monitor (without KVM extender)**

You may choose to use a standard signal cable or make a cable using the "Video signal cable connector" pin-out in Appendix C. When making a cable, 3M Touch Systems recommends you use a high-quality shielded cable such as Belden cables 1417B, 1418B, 1522A, or 1826A.



**Important**

- To reduce the risk of voiding FCC and CE compliance and reducing the performance of the ET 350 monitor, when making your own cable, reduce the sensitivity of the ET 350 monitor to electrical and radio frequency noise by connecting the cable shield to the connector shield (360° shield) on both ends of the cable.
  - Before attaching or removing communication cables, disconnect power to the ET 350 monitor.
- 

To connect the video signal cable, follow these steps:

1. **If the monitor has a hatch**, the hatch must be open to access connectors. Remove the four #6-32 Phillips screws affixing the hatch to the monitor and open the hatch cover. For an illustration of the locations of these screws, refer to Figure 13 on page 38.
2. Connect one end of the video signal cable to the VGA signal cable connector on the side of the monitor.
3. Tighten the screws on the signal cable.
4. Connect the other end of the signal cable to the video adapter port on the computer.
5. Tighten the screws of the signal cable to ensure proper connection.
6. After connecting the video signal cable to the monitor and computer, make sure you have the latest video drivers for the video adapter. You may be able to download the most recent drivers from the video adapter manufacturer's web site.

**Step 2:  
Connect serial  
cable**

The ET 350 monitor uses a 9-pin COM port for touch screen communication with the host computer. The standard length of the serial cable is 6 feet. There are 25-foot and 50-foot cable options available.

Use a standard cable or make one using the “Serial port RS-232C connector” in Appendix C. Note that the pin-out presents the ET 350 monitor as a Data Communication Equipment (DCE) device so that a “straight-through” cable can be used.

To connect the serial cable:

1. **If the monitor has a hatch**, make sure that the hatch is open (it should have been opened when connecting the video cable). The hatch must be open to access connectors.
2. Connect one end of the serial cable to the serial cable connector on the side of the monitor.

### Step 3: Connect to power supply

---

#### Important

To reduce the risk of voiding FCC and CE compliance and reducing the performance of the ET 350 monitor, when making your own cable, reduce the sensitivity of the ET 350 monitor to electrical and radio frequency noise by connecting the cable shield to the connector shield (360° shield) on both ends of the cable.

---

3. Connect the other end of the serial cable to the serial port on the computer.
4. Tighten the screws of the serial cable to ensure proper connection.

The ET 350 monitor can be connected to an AC power supply in two ways: with a standard AC power cable or with fixed field wiring.

#### Standard AC power supply

Use an AC power cable that is appropriate for the power scheme in your country or region:

- For applications in Europe, use a harmonized AC power cable. The universal power supply of the ET 350 monitor automatically senses the voltage from the external source and, within the range 115 to 230 VAC, 50 to 60 Hz, supplies the appropriate power without requiring any adjustment.
- For North American applications, use a standard AC power cable.

Both types of cable are available from 3M Touch Systems and come with either an IEC connector or terminal strip wiring.

---

#### **Warning**

To reduce the risk of fire or electric shock which could result in serious personal injury or death:

- Install the ET 350 monitor close to the power source so the unit can be easily and quickly disconnected. For permanently connected equipment, a readily accessible disconnect device must be incorporated in the fixed wiring.
  - Wiring installation should be done by a licensed journeyman electrician and must comply with federal and local electrical codes.
- 

#### Important

Before attaching or removing communication cables, disconnect power to the ET 350.

---

To connect the AC power cable:

1. **If the monitor has a hatch**, make sure that the hatch is open (it should have been opened when connecting the video cable). The hatch must be open to access connectors.
2. Connect the power cable to the socket on the side of the monitor.
3. Connect the other end of the cable to a standard 15-ampere (or less) branch circuit.

### AC power supply with fixed field wiring (ET 350R monitor and ET 350L3 monitor only)

#### Warning

- To reduce the risk of fire or electric shock which could result in serious personal injury or death, wiring installation should be done by a licensed journeyman electrician and must comply with federal and local electrical codes.
- To reduce the risk of electric shock which could result in serious personal injury or death, provide adequate strain relief for all communication and power cables.

To connect the power supply with fixed field wiring, follow these steps:

1. Make sure the AC power supply is disconnected at its source.
2. Strip about 1/8-inch (3 mm) of insulation from the end of the neutral, ground, and line wires.

#### Warning

To reduce the risk of fire or electric shock which could result in serious personal injury or death, when connecting power with fixed field wiring, the power cable must be double insulated. A clear, flexible insulator (supplied) must cover the portion of the cable that is not double insulated when connecting to a terminal strip connector.

3. Measure and, if necessary, cut the clear, flexible insulator (supplied) so that it will cover the unjacketed portion of the power cable and overlap the jacketed portion by at least one inch.
4. Slide the insulator up the power cable.
5. Insert the stripped end of the AC power cable wire (neutral) into the terminal strip's side connector (Figure 6).

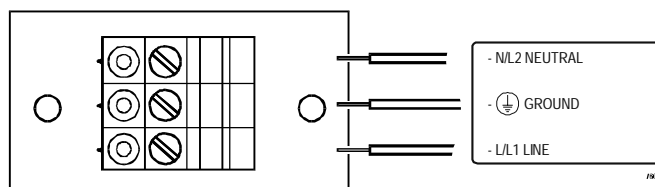
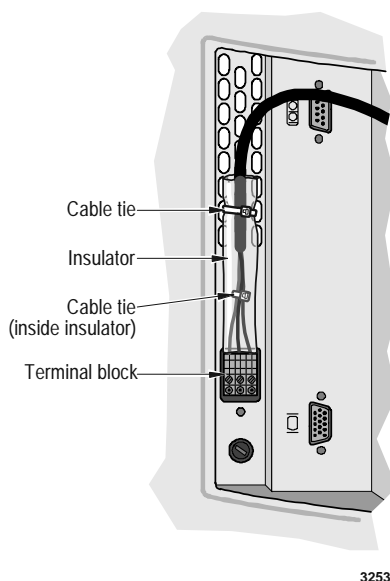

Figure 6: Connecting AC power cable wires to connectors

6. Using a 1/8-inch flathead screwdriver, turn the terminal block's screw clockwise until the neutral cable wire is firmly attached to the ET 350 monitor.
7. Repeat (5) and (6) for the ground and line cable wires and then tighten the screws on the terminal block to a torque of 10 inch-pounds.
8. Fasten a cable tie around the three wires at about one inch from the terminal block (Figure 7).



**Figure 7: Terminal connection for AC power (ET 350R, ET 350L3 monitors) and for DC power**

9. Make sure that one end of the insulator is flush with the terminal connector and the other end overlaps the power cable jacket by at least one inch.
10. To prevent the insulator from moving, secure the insulator to the chassis of the monitor using a cable tie or other equivalent securing device.

### **DC power supply (option)**

To connect the ET 350 Monitor to DC power supply, follow these steps:

1. Make sure that the DC power supply is disconnected at its source.
2. Strip about 1/8-inch (3 mm) of insulation from the end of the negative, positive, and ground wires.
3. Measure and, if necessary, cut the clear flexible insulator (supplied) so that it will cover the unjacketed portion of the power cable and overlap the jacketed portion by at least 1 inch.
4. Slide the insulator up the power cable.
5. Insert the DC- cable wire into the side connector of the terminal strip (Figure 8).

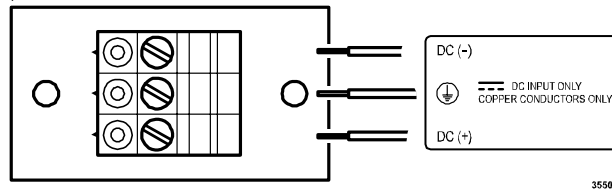

**Figure 8: Connecting DC power cable wires to connectors**

6. Using a 1/8-inch flathead screwdriver, turn the screw on the terminal strip clockwise until the negative cable wire is firmly attached.
7. Repeat steps (5) and (6) for the “ground” and DC+ cable wires and then tighten screws on the terminal block to a torque of 10 inch-pounds.
8. Fasten a cable tie around the three wires at about one inch from the terminal block (Figure 7).
9. Make sure that one end of the insulator is flush with the terminal connector and the other end overlaps the power cable jacket by at least 1 inch.
10. To prevent the insulator from moving down the cable, secure the insulator to the chassis of the monitor by using a cable tie or other equivalent securing device.
11. Connect power to the DC power cable at its source.

## Step 4: Adjust display settings

### Open the enclosure

To access the monitor’s controls, you must open it. To open the enclosure:

1. Put on an electrostatic discharge grounding wrist strap.

#### Important

To prevent damage from electrostatic discharge (ESD), wear a grounding wrist strap when working with electronic components inside the enclosure. Follow the instructions that come with the wrist strap. If a grounding wrist strap is not available, touch a grounded metal object to discharge any static from your body.

2. Make sure that the power supply for the monitor is connected.
3. Open the monitor enclosure.
  - If your unit has security screws on the back of the bezel, remove them with the appropriate screwdriver (the locations of the security screws are shown in Figure 13 on page 38).
  - Apply a 5/32-inch (4 mm) Allen key to the latch screw on the top of the enclosure. Turn the key counterclockwise ¼ turn, or until you feel the unit opening.

It is not necessary to fully open the enclosure to operate display controls. With the enclosure slightly ajar, you can access the display-setting controls (located on the back of the monitor’s display, near the top). Table D summarizes the functions of each on-screen control:

Table D: Summary of on-screen display controls

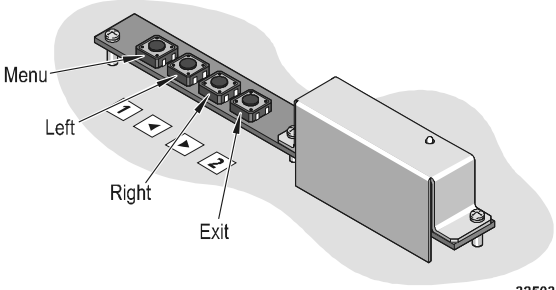
Symbol	Name	Function of the control	Display controls inside ET 350 monitor enclosure
<b>1</b>	<b>Menu</b>	To start up the on-screen display menus and to move through the menu options.	
<b>◀</b>	<b>Left</b>	To move through main menu icons (PC, OSD, Utility, and Auto) and to decrease setting values.	
<b>▶</b>	<b>Right</b>	To move through main menu icons (PC, OSD, Utility, and Auto) and to increase setting values.	
<b>2</b>	<b>Exit</b>	To exit the on-screen display menus. Changes are saved automatically.	

### Auto display setup

Run the auto display setup before manually adjusting individual display settings. Auto display setup sets pre-programmed optimal display settings.

1. Press **1** once.

The display control menu appears on the screen and the PC icon at the top of the on-screen display is selected (Figure 9).

2. Using the on-screen display controls, select the “Auto” menu item (Figure 10).

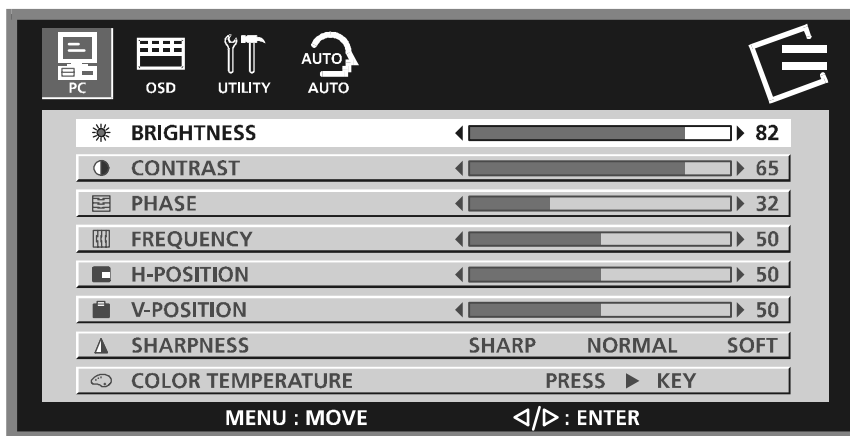

Figure 9: PC menu options



Figure 10: Auto display setup

32511

3. Press **1** once.

The display settings are automatically optimized.

### Manually adjusting display settings

If the auto display setup settings are not suitable for your application, you can make manual adjustments to the display settings. Follow these steps:

1. Press **1** once.

The control menu appears on the screen (Figure 9) and the PC icon at the top of the on-screen display is selected.

The display settings for the monitor are located in the PC menu.

2. To change brightness, press **1** again.

The brightness setting is selected.

3. To increase the brightness of the display, press **▶**. To decrease the brightness of the display, press **◀**. Changes to settings are saved automatically.

4. To move through the display setting options, press **1**. Use the **◀** and **▶** controls to adjust other settings.

5. When you are finished adjusting the display settings, press **2**. The on-screen display menu disappears.

## Other on-screen display options

The most commonly used on-screen display options are those that appear under the PC and Auto icons. Other on-screen options that can be set using the controls are summarized below.

### OSD (on screen display) menu

The settings in the OSD menu permit you to change the position and appearance of OSD menus, the duration of a display before timeout, and the language (English or Korean) of the OSD menus.

By increasing or decreasing the value of H-Position, for example, the OSD menus can be shifted left or right on the display.

### Utility menu

The settings in the Utility menu allow you to reset display settings to the monitor manufacturer's display setting defaults and to get information on the display's current resolution and frequency. Some units allow the user to turn the display's power management system (DPMS) on or off (the default setting is "on"). For the ET 350 monitor, the DPMS should not be turned off. For ET 35X monitors with heater, see installation instructions that come with heater units regarding DPMS settings.

---

### Warning

To reduce the risk of electric shock or mechanical impact which could result in serious personal injury or death, if your ET unit has a display power management system (DPMS) that is configurable from the display's on-screen utility menu, do not turn off the DPMS.

---

**Note:** The Dynamic Brightness control in the Utility menu is not adjustable with the ET 350 monitor and so that menu item is dimmed.

## Step 5: Install software and import TouchSurround files

### Installing touch screen software

To install the touch screen drivers and utilities for the ET 350 monitor, follow the instructions below that correspond to the operating system running on the host computer. The ET 350 monitor currently supports Windows XP Professional, Windows 2000 Professional, Windows NT 4.0, and Windows 9X operating systems.

#### Installing the driver for Windows XP/2000 operating systems

To install touch screen software for Windows XP or Windows 2000 operating systems:

1. Find the floppy disk that includes the driver for Windows XP/2000 operating systems, insert it in the disk drive, and browse the floppy disk to find the file named setup.exe.

2. Open setup.exe.

The installation Welcome window appears.



3. Follow the screen prompts to install the driver and then follow the on-screen instructions of the Setup Wizard.

**Note:** When the Baseline dialog box appears, select Skip. When the Linearization Data Download dialog box appears, select Skip. Baseline and linearization data are built into the monitor at the factory.

4. When the Setup Wizard finishes, an Install Successful window appears.

### **Installing the drivers for Windows NT 4.0 and Windows 9X operating systems**

To install the touch screen software for Windows NT 4.0 and Windows 9X operating systems, follow these steps:

1. Find the floppy disk that includes the drivers for Windows NT 4.0 and Windows 9X operating systems, insert it in the disk drive, and browse the floppy disk to find the file named install.exe.

2. Open install.exe.

The installation Welcome window appears.

3. Choose to install the driver and then follow the on-screen prompts to install the driver.

When the software is installed, you will be prompted to restart.

---

#### **Important**

**For Windows 98 operating system only:** Turn off the Advanced Configuration and Power Interface (ACPI). If the Windows 98 operating system ACPI feature is not turned off, the COM port may not be accessible after re-booting the host computer. For detailed instructions, refer to your Windows 98 operating system user documentation.

---

4. **For Windows 98 operating system only**, turn off the Advanced Configuration and Power Interface (ACPI). Follows these steps:
  - a. From the Windows operating system Start menu, select Settings, then select Control Panel, and then open System.
  - b. Click the Device Manager tab, then open System Devices, and then right-click ACPI BIOS and click Properties. A dialog box appears.
  - c. Click the Driver tab, then click Update Driver, and then click Next.
  - d. Click Display a list of all the drivers, then click Next, and then click Show all hardware. A dialog box appears.
  - e. From the Manufacturers options (on the left side of the dialog box), select Standard System Devices and from the Models options (on the right), select PCI Bus, and then select Next.

- f. Click Yes in reply to the question: Are you sure you want to use this driver? The Update Device Driver Wizard appears.
- g. Insert your CD-ROM for the Windows 98 operating system. (If the CD-ROM welcome page appears, close it so you can see the Wizard dialog box.)
- h. Click Next in the Wizard dialog box and, after a message appears confirming that the Windows operating system has finished its task, click Finish.
- i. Click Yes when the System Settings Change box appears asking if you want to restart your computer.
- j. After restarting the computer, confirm that the driver and controller are communicating.

## **Importing standard TouchSurround definitions**

### **Windows XP/2000 operating system**

To import the standard TouchSurround definition for Windows XP and Windows 2000 operating systems, follow these steps:

1. Find the button definition file 350.reg on the floppy disk with the driver for Windows XP/2000 operating systems and copy it to the hard drive of your host computer.
2. Double-click the 350.reg file.

A dialog box appears asking whether you want to add the TouchSurround definition file information to the registry.
3. Select Yes.

A dialog box appears verifying that the file transfer has occurred.
4. Select OK.
5. Open the Configuration Utility dialog box and select TouchSurround.

The TouchSurround button definition dialog box appears.
6. Select OK.

The Configuration Utility dialog box re-appears. The standard button definition file takes effect immediately. It is not necessary to reboot.

### **Windows NT 4.0/9X operating systems**

The standard TouchSurround definition for Windows NT 4.0 and Windows 9X operating systems is imported when installing the driver. If you can't find the TouchSurround definition file, you may need to reinstall the software. Refer to the software guide appropriate for your operating system (see "Software guides" on page 2).

To import the standard TouchSurround definition for Windows NT 4.0 and Windows 9X operating systems, follow these steps:

1. Select the Windows Start button, select Programs, and then select Command Prompt.
2. At the command prompt, type
  - CD\TOUCH\NT for Windows NT
  - CD\TOUCH\W9X for Windows 9X
3. Type TOUCHINI /i350.ini  
where 350.ini is the standard button definition file.  
(**Note:** There is a space between TOUCHINI and the forward slash.)

The standard TouchSurround button configuration takes effect the next time you start Windows NT 4.0 or Windows 9X operating systems.

### Customizing drivers

Some of the driver features that can be customized include double touch settings, touch screen sensitivity, and beep on touch. For instructions on how to customize driver features, refer to the appropriate software guide (see “Software guides” on page 2).

### Step 6: Set “backlights saver” and “safe touch”

#### Backlights saver

You can extend the life of the monitor’s backlights (and conserve power) by setting the host computer’s energy saver to “turn off the monitor” after a specified number of minutes of inactivity. The energy saver (which is, in effect, a backlights saver) is adjusted in the Display Properties dialog box of Windows XP, 2000, and 9X operating systems.

Windows NT 4.0 operating system does not have an energy saver, so if the host computer is running with Windows NT 4.0 operating system, the backlights will be on whenever the unit is powered up (even if the Windows NT 4.0 operating system screen saver is set to display a blank screen).

#### Safe touch

This setting changes the way the touch screen responds when the user touches the screen to reactivate the monitor following a period when the backlights have been off.

With a safe touch setting applied, the user will not accidentally activate a touch screen button on the part of the screen that is touched.

If the ET 350 monitor is running an application or is in a setting in which unintentionally activating a button on the touch screen might have harmful consequences for people or equipment, 3M Touch Systems recommends creating a “safe touch” setting.

---

 **Warning**

To reduce the risk of electric shock or mechanical impact which could result in serious personal injury or death:

- Apply a “safe touch” setting, especially if the monitor is running an application or is in a setting where safety is a concern.
- Do not use a third party screen saver that may affect the “safe touch” setting and could in turn cause connected peripheral equipment to start or stop inadvertently.

---

The procedure for applying a safe touch setting differs depending on the operating system.

**Safe touch for Windows XP/2000 operating systems**

To apply a safe touch setting with Windows XP and 2000 operating systems, follow these steps:

1. Close all Windows operating system applications and then open the Display Properties dialog box (for instructions on how to open Display Properties, refer to your operating system’s help file).
2. Select the Screen Saver tab.
3. *In the screen saver section* of the dialog box, enter in the “Wait” box the number of minutes that you want to elapse from the last time the screen is touched to when the screen saver is activated.
4. *In the energy saver section* of the dialog box, select Power.

The power dialog box appears (called Power Scheme in Windows XP; called Power Options Properties in Windows 2000).

5. In the “Turn off monitor” pull-down menu, set the number of minutes that will elapse from the last time the screen is touched to when the energy saver is activated. The period chosen must be *at least one minute greater than the time you set (in step 3, above) for the screen saver.*

---

 **Warning**

To reduce the risk of electric shock or mechanical impact which could result in serious personal injury or death, set the “safe touch” setting correctly, with the number of minutes entered for the Windows operating system energy saver being at least one minute greater than the time entered for the Windows operating system screen saver.

---

6. Select OK.
7. If your ET unit has a display power management system (DPMS), that is configurable from the display's on-screen menu options, make sure that it is turned *on*. For details on how to check DPMS, see "Utility menu" on page 22.

### **Safe touch for Windows 9X operating system**

To apply a safe touch setting with a Windows 9X operating system, follow these steps:

1. Close all Windows operating system applications, then open the Display Properties dialog box (for instructions on how to open Display Properties, refer to your operating system's help file).
2. Select the Screen Saver tab.
3. *In the screen saver section* of the dialog box, enter in the "Wait" box the number of minutes that you want to elapse from the last time the screen is touched to when the screen saver is activated.
4. *In the energy saver section* of the dialog box, select Settings.

The power management dialog box appears.

5. In the "Turn off monitor" pull-down menu, set the number of minutes that will elapse from the last time the screen is touched to when the energy saver is activated. The period chosen must be *at least one minute greater than the time you set (in step 3, above) for the screen saver*.

---

### **Warning**

To reduce the risk of electric shock or mechanical impact which could result in serious personal injury or death, set the "safe touch" setting correctly, with the number of minutes entered for the Windows operating system energy saver being at least one minute greater than the time entered for the Windows operating system screen saver.

---

6. Select OK.
7. If your ET unit has a display power management system (DPMS), that is configurable from the display's on-screen menu options, make sure that it is turned *on*. For details on how to check DPMS, see "Utility menu" on page 22.

### **Safe touch for Windows NT 4.0 operating system**

Windows NT 4.0 operating system does not have an energy saver, so it is not necessary to apply a safe touch setting with this operating system.

## Step 7: Close enclosure and hatch

### Close enclosure

When you are finished adjusting the display settings, close the enclosure:

1. Close the bezel assembly and lock the latch screw with the Allen key.
2. If applicable, replace the four security screws. Tighten the screws to a torque of 10 inch-pounds.

### Close hatch

To close the hatch, insert the four #6-32 Phillips screws loosely. Using a No. 1 Phillips torque screwdriver, gradually tighten diagonal pairs of screws until all are equally tight at a torque of 7 inch-pounds. This may require about three rounds of tightening.

## Step 8: Mount monitor

Two of the three ET 350 monitor models come with their own mounting/sealing equipment and mounting instructions (and the instructions are also available for download from [www.3Mtouch.com](http://www.3Mtouch.com)):

- ET 350R monitor with a NEMA 4X panel gasket
- ET 350L3 monitor with a NEMA 4X hatch

The ET 350L2 monitor does not come with mounting materials, but there are optional mounting kits available from 3M Touch Systems (see below).

For details of the features of the three ET 350 monitor models, see “Distinctive features of each model” on page 8.

### Optional mounting kits

Each mounting kit comes with its own set of installation instructions (also available for download from [www.3Mtouch.com](http://www.3Mtouch.com)):

- **Boom mount kit** allows the monitor to be mounted on a post, boom or suspension arm with a NEMA 4X sealed hatch or extended hatch.
- **Rack mount kit** makes it possible to mount the monitor on a standard 19-inch industrial rack.
- **Desktop stand kit** is a two-piece desktop stand option that allows the monitor to be set on a desk, bench, or table top.

A **security hardware kit**, also available from 3M Touch Systems, includes four security screws and a security screwdriver that make it possible to lock the back of the ET 350 monitor enclosure. Once the security screws have been inserted, the monitor cannot be opened from the front by an unauthorized user.

---

### **Warning**

To reduce the risk of electric shock which could result in serious personal injury or death, before removing the ET 350 monitor from its mounting, disconnect power to the unit.

---

---

**Important**

If security screws are used, the operator will not be able to access the enclosure without a security screwdriver. This means that the operator may be unable to perform such tasks as changing display settings.

---

The locations for attaching the security screws are shown in Figure 13 on page 38.

**Mounting the ET 350 monitor with Moisture Deflector**

The ET 350 monitor with Moisture Deflector comes with four sealing screws fastened to the back of the unit. 3M Touch Systems recommends that if you need to remove the sealing screws to access the enclosure, you re-attach the screws after closing the enclosure.

The ET 350 monitor with Moisture Deflector must be mounted vertically—with no more than 10 degrees variance from vertical—for the Moisture Deflector to operate. As long as the 10 degree rule is observed, it is possible to mount the monitor with the Moisture Deflector using any of the mounting kits described above.





## CHAPTER 3

# Maintaining the monitor

### About the chapter

This chapter describes how to:

- Clean the touch screen and enclosure
- Replace backlights
- Replace the fuse
- Check gaskets for damage or improper functioning
- Maintain the ET 350 monitor with Moisture Deflector

---

#### **Warning**

To reduce the risk of electric shock which could result in serious personal injury or death, do not open the power supply in the ET 350 monitor. It contains hazardous voltages. The power supply has no user-serviceable parts or adjustments inside.

---

### Cleaning

#### **Cleaning the touch screen**

When cleaning the front surface of the NFI touch screen, use any chemical that does not corrode glass. The touch screen will function, even if its front surface is pitted or damaged by a chemical.

---

#### **Caution**

To reduce the risk of minor or moderate injury from contact with cleaning solutions or fluids, through means such as ingestion and skin contact, refer to the cleaner manufacturer's material safety data sheet and follow all instructions and recommendations.

---

#### **Important**

Clean the back of the touch screen (the surface that is inside the touch screen and is exposed to the graphic underlay) using only cleaning solutions and materials designed for coated optics. The back of the touch screen is covered with a coating that is easily damaged by commercial glass cleaners or a regular cloth.

---

## Cleaning the enclosure

Use a 50 percent solution of alcohol (ethanol or isopropanol) in water on a cotton gauze pad or soft cotton cloth to clean the enclosure. Be sure to apply the alcohol solution to the cloth only, not directly to the enclosure.

---

### Warning

To reduce the risk of fire or explosion which could result in serious personal injury or death, when using a flammable or combustible cleaning solution or fluid on or near the ET 350 monitor, refer to the cleaner manufacturer's material safety data sheet and follow all instructions and recommendations.

---

## Replacing backlights

For information on replacing backlights for the ET 350 monitor, contact 3M Touch Systems customer service (see "Contacting 3M Touch Systems" on page 3).

## Replacing the fuse

The fuse holder is adjacent to the power socket of the ET 350 monitor.

### Tools required

- 3/16-inch flat-blade screwdriver
- No. 1 Phillips torque screwdriver (for ET 350L3 monitor)

### Steps

To replace the fuse:

1. Disconnect power to the ET 350 monitor.
- 

### Important

Do not replace the fuse while the monitor is connected to its power supply.

---

2. **If the monitor has a hatch**, remove the four #6-32 Phillips screws affixing the hatch to the monitor and then open the hatch cover. Once the hatch is open, the fuse holder should be visible.
3. Locate the fuse holder. It is adjacent to the power cable connector (see Figure 5 on page 14).
4. Insert an appropriate screwdriver into the fuse holder's slot (Figure 11).

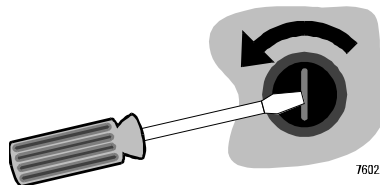
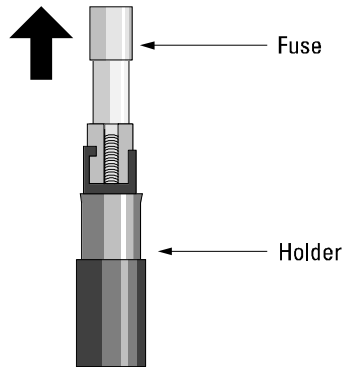

Figure 11: Loosening fuse holder

5. While gently pressing the fuse holder, turn the screwdriver counterclockwise.  
The fuse holder will pop out of the ET 350 monitor.
6. Remove the fuse holder with the fuse.
7. Detach the fuse from the fuse holder by pulling on it gently.



76011

**Figure 12: Removing fuse from fuse holder**

### **Warning**

To reduce the risk of fire or electric shock which could result in serious personal injury or death, when replacing a fuse or other part, use a part of the same type rating specified by 3M Touch Systems.

8. Replace the fuse. For fuse specifications, see “Fuses” on page 52.
9. Reinstall the fuse holder in the ET 350 monitor.
10. While gently pressing the fuse holder, turn the screwdriver clockwise.
11. **If the monitor has a hatch**, close the hatch cover (opened earlier):  
Insert all screws loosely. Using a No. 1 Phillips torque screwdriver, gradually tighten diagonal pairs of screws until all are equally tight at a torque of 7 inch-pounds. This may require about three rounds of tightening.
12. Re-connect power to the unit.

## Checking gaskets

Follow these guidelines to check and clean the gaskets on your monitor:

- Make sure there is no debris on gaskets that will prevent a seal.
- If debris needs to be cleaned from gaskets, do so gently.
- If gaskets are torn or damaged, return to 3M Touch Systems for servicing.

## Maintaining the ET 350 monitor with Moisture Deflector

The Moisture Deflector is made of durable plastic and, like other 3M Dynapro components, is designed to function in rugged conditions.

It is not indestructible, however. Follow these guidelines to extend its life and help ensure optimal performance:

- Before starting the ET 350 monitor with Moisture Deflector, make sure that the temperature is at least 0°C.
- Do not hang anything from the Moisture Deflector. Doing so may cause it to perform poorly.
- Before opening the enclosure of the ET 350 monitor with Moisture Deflector, make sure that the unit is completely dry. If water has collected on the top of the enclosure and is not removed before opening it, moisture might run into the unit.
- To open the unit, you will need to remove the four sealing screws attached to the back of the unit. After closing the enclosure, re-attach the sealing screws.
- When handling the monitor, do not grasp it by the Moisture Deflector.
- If it is necessary to ship the monitor for any reason, use the original packing materials, if possible. When packing the unit, take care to protect the Moisture Deflector from being damaged during shipping.

## CHAPTER 4

# TouchSurround and graphic underlay

### About the chapter

This chapter describes:

- The function of the TouchSurround and graphic underlay
- How to get a custom underlay
- How to replace the underlay

---

 **Warning**

To reduce the risk of electric shock which could result in serious personal injury or death, do not open the power supply in the ET 350 monitor. It contains hazardous voltages. The power supply has no user-serviceable parts or adjustments inside.

---

### About the TouchSurround

The TouchSurround is the touch-sensitive area of the computer screen around the LCD display (see Figure 1 on page 6). A graphic underlay is located under the touch screen and it identifies buttons, touchable symbols, pictures, and icons.

#### Standard TouchSurrounds

Standard TouchSurround layouts from 3M Touch Systems feature predefined buttons that permit some keyboard functions (for example, Enter) to be performed by touch. The functions of the buttons can be changed by following instructions in the software guide appropriate for your operating system (see “Software guides” on page 2).

#### Custom TouchSurrounds

Custom TouchSurrounds let you customize the user’s interface with the monitor. You can change the number, size, and position of buttons, and create icons or touchable graphics that suit your needs.

If you need a custom TouchSurround, you can order the monitor with a custom TouchSurround or you can replace the TouchSurround graphic underlay later, as described in this chapter.

## Creating your own graphic underlay

If you need a custom graphic underlay, it is recommended that you order it from 3M Touch Systems, especially if the underlay will need to withstand temperature and humidity extremes.

---

### Important

For the TouchSurround graphic underlay to withstand the same temperature and humidity extremes that the ET 350 monitor can withstand, you should not attempt to create your own underlay. Instead, order your underlay from 3M Touch Systems.

---

The monitor is designed to operate in temperatures from 32°F to 122°F (0°C to 50°C), and with humidity up to 95% (non-condensing). If you do not need this level of durability, you may choose to print the underlay yourself. There are two possible methods:

- **Silk screen printing** onto a clear, soft, matte finish polycarbonate sheet. 3M Touch Systems recommends that you use a sheet that is 0.015 inches thick and printed on the “back” side (to prevent the printed surface from touching the glass).
- **Inkjet or color laser printing** onto paper or a plastic sheet. Avoid having the printed surface in direct contact with the touch screen—under certain conditions it could adhere to the glass. Laminate the underlay with clear matte-finish plastic to prevent contact between the printed surface and the glass.

With either method, make sure the surface in contact with the glass has a matte finish to prevent the optical distortion known as Newton's Rings.

After installing a new underlay, you will need to define new positions, actions and functions for your buttons or icons. For instructions on doing this, refer to the appropriate software guide (see “Software guides” on page 2).

## Replacing a TouchSurround graphic underlay

### What you will need

The rest of this chapter describes how to remove the graphic underlay that came with your monitor and replace it with a new, custom underlay.

To do the tasks described in this section, you will need:

- A clean, ESD-protected environment with a work bench.
- Two people: one to replace the underlay and another to support the monitor.
- The following tools and materials:
  - 5/32-inch (4 mm) Allen key (supplied with the monitor)
  - 5/16-inch torque hex nut driver
  - Latex or cotton work gloves
  - Cleaning solution and cloths designed for cleaning coated optical glass
  - Security screwdriver, if the enclosure is secured with security screws

---

### Important

To prevent damage from electrostatic discharge (ESD), wear a grounding wrist strap when working with electronic components inside the enclosure. Follow the instructions that accompany the wrist strap. If a grounding strap is not available, touch a grounded metal object to discharge any static charge from your body.

---

### Opening monitor

To open the enclosure of the monitor:

1. Disconnect power to the ET 350 monitor.
- 

### Warning

To reduce the risk of electric shock which could result in serious personal injury or death, before removing the ET 350 monitor from its mounting, disconnect power to the unit.

---

2. It is recommended that the monitor be removed from its mounting and brought to a clean work area:
  - a. Disconnect all communication connections from the monitor. For more information about connections, see Chapter 2, starting at page 13.
  - b. Remove the monitor from its mounting.
  - c. Lay the monitor on a flat surface. You may want to place foam pads or other material underneath the unit to protect the front surface of the touch screen and its bezel.

3. Put on an ESD grounding wrist strap if one is available. If a grounding wrist strap is not available, touch a grounded metal object to discharge any static charge from your body.
4. Open the enclosure.
  - If your unit has security screws on the back of the bezel, remove them with a security screwdriver (the locations of the security screws are shown in Figure 13).

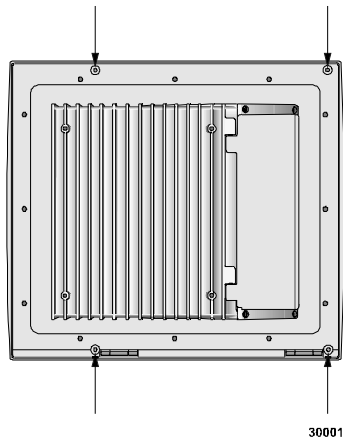

**Figure 13: Location of optional security screws**

- Apply a 5/32-inch (4 mm) Allen key to the latch screw on the top of the enclosure. Turn the key counterclockwise  $\frac{1}{4}$  turn, or until you feel the unit opening.
5. Have one person support the enclosure in the open position during the rest of this procedure so that the monitor does not tip.



6. Carefully disconnect the touch screen tail connector from the controller board (Figure 14).
  - a. Gently pull out the touch screen connector's retaining clip with two fingers.
  - b. Gently pull the touch screen tail from the controller and through the ferrite block.

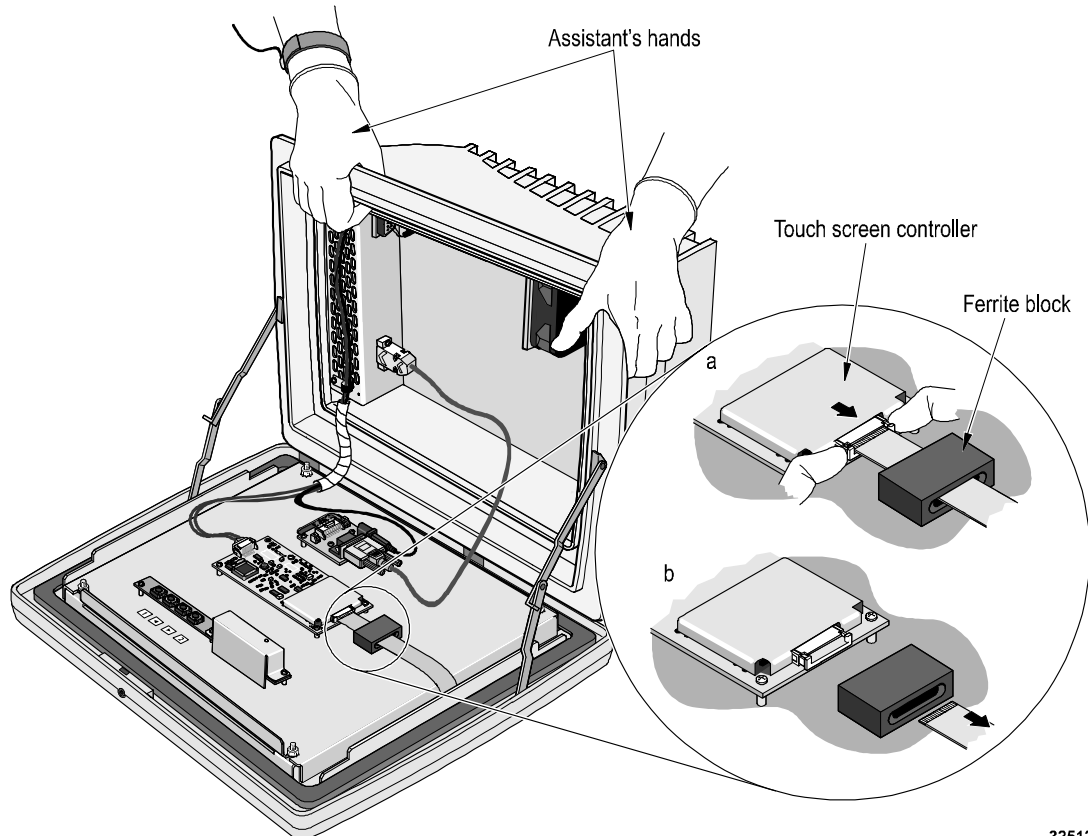

Figure 14: Disconnecting touch screen tail connector

32512

7. Using a 5/16-inch torque hex nut drive, remove the four display panel nuts and washers (Figure 15).

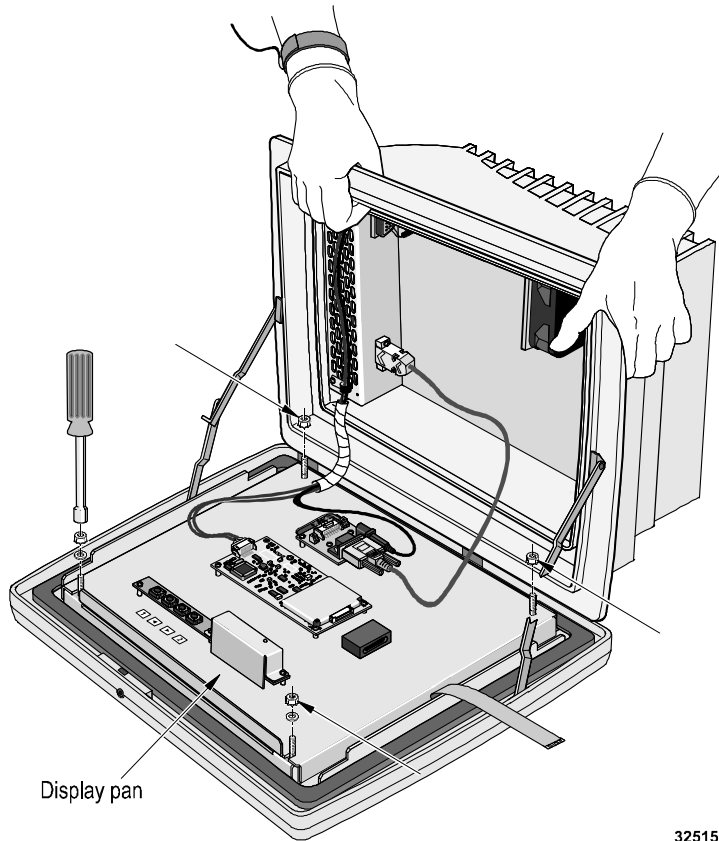

Figure 15: Removing display panel nuts and washers

8. Carefully slide the display pan away from the threaded studs and lift it to a vertical position, taking care not to damage the cables connected to the components on the display pan (Figure 16):
  - a. Lift the hinge side of the display pan up from the threaded studs.
  - b. Slide the display pan away from the other two threaded studs.
  - c. Lift the display pan to a vertical position.
9. Have one person support both the display pan and the main enclosure while the other person replaces the underlay.

The glass surface under the underlay marks easily. Do not touch or scratch the glass while replacing the underlay. If you do touch the glass and leave stains or fingerprints, clean it before you install the new underlay.

---

### Important

Clean the back of the touch screen (the surface that is inside the touch screen and exposed to the graphic underlay) using only cleaning solutions and materials designed for coated optics. The back of the touch screen is covered with a coating that is easily damaged by commercial glass cleaners or a regular cloth.

---

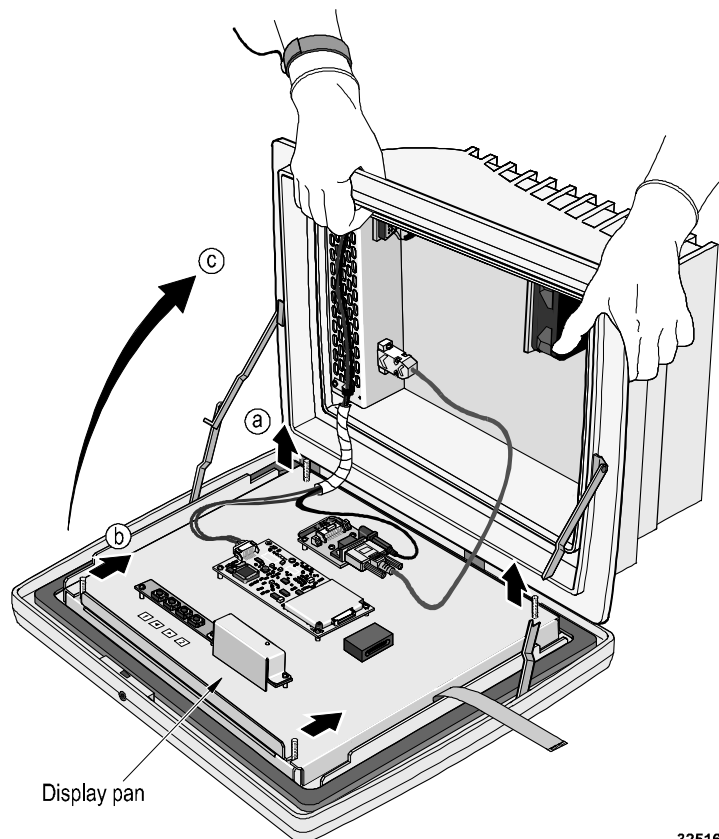
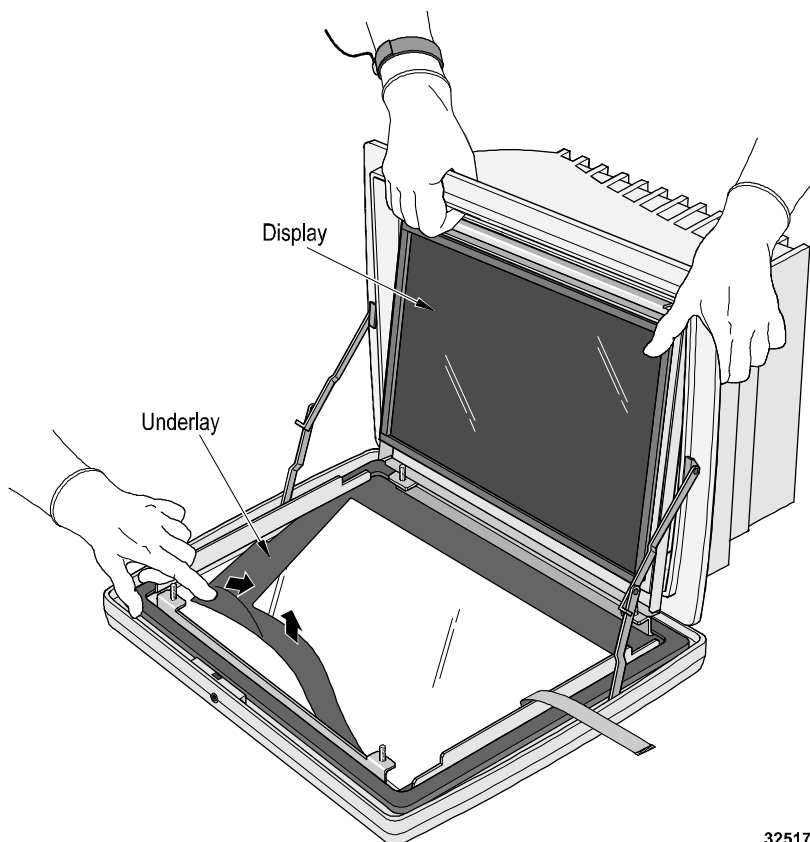

Figure 16: Sliding display pan out and lifting it

32516

10. Remove the underlay in stages. The underlay is larger than the opening in the sheet metal retaining frame. You can bend the underlay, but do not tear or crease it.

To loosen the underlay from the glass surface, use a finger and push a corner of the underlay towards the center of the glass. As the underlay buckles and the corner comes into view, pull it up to clear the retaining frame. Repeat at each corner until the underlay is free (Figure 17).



32517

**Figure 17: Removing original underlay**

11. Remove the custom underlay from its packaging and make sure it is clean. If necessary, clean it with a cleaning solution and cloth designed for cleaning coated optical glass.

12. Being careful not to damage the new underlay, place it under the retaining frame in stages: slide one corner in place under the retaining frame, then bend the underlay and slide in the next corner. Continue until the underlay is in place against the surface of the glass (Figure 18).

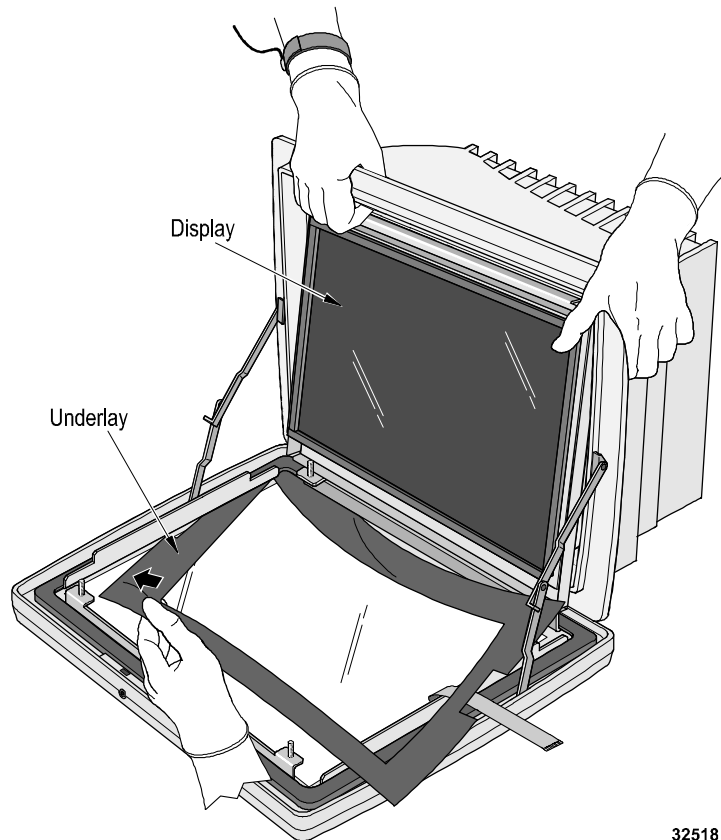

32518

**Figure 18: Placing new underlay**

13. Lower the display pan to its original position over the underlay and secure it with the nuts that were removed earlier. Make sure you use the washers with the nuts on the hinge side of the display pan.

Tighten the nuts to a torque of 10 inch-pounds.

14. Gently reconnect the touch screen tail to the controller (Figure 19):
  - a. Pull out the touch screen connector's retaining clip.
  - b. Slide the touch screen tail through ferrite and insert it into the connector.
  - c. Press the retaining clip back into the controller.

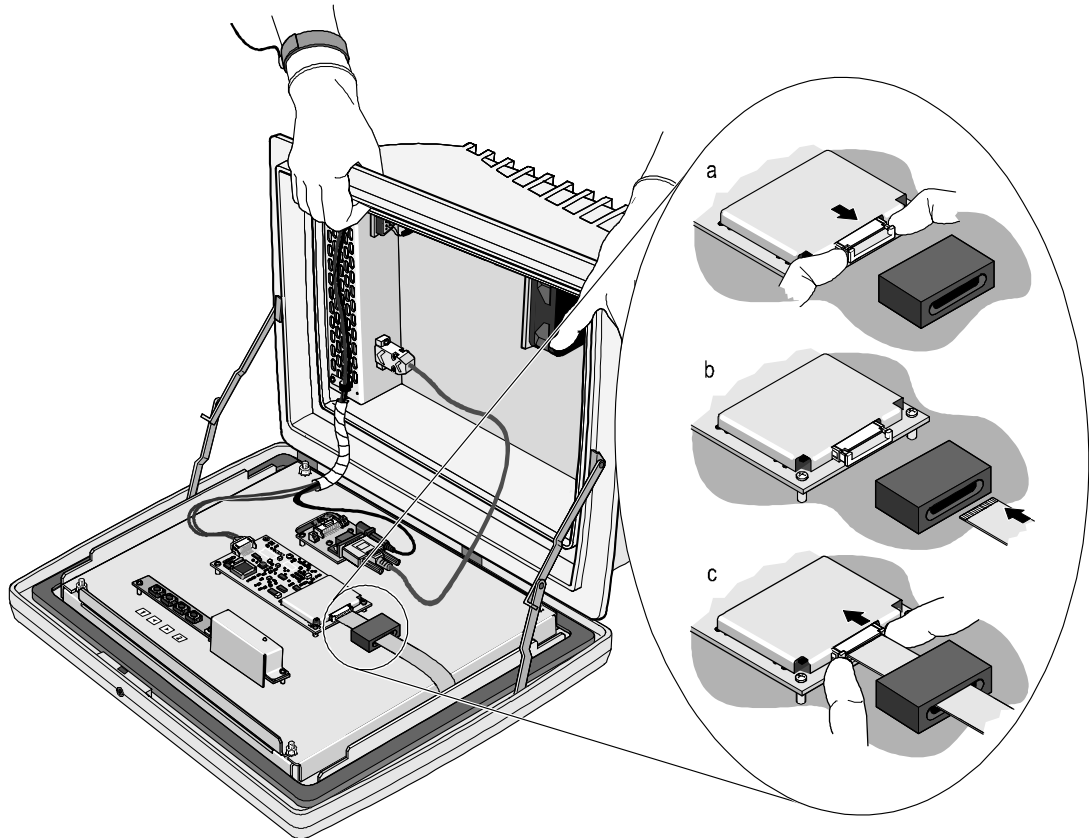

32519

**Figure 19: Reconnecting touch screen tail**

15. Close the bezel assembly and lock it with a flat-blade screwdriver or the Allen key.
16. If the bezel assembly was secured with security screws, replace them.
17. If you removed the ET 350 monitor from a mounting earlier, re-mount it.
18. Re-connect the communications cables.
19. Re-connect the monitor's power cord to the power supply.

## CHAPTER 5

# Troubleshooting

### About the chapter

This chapter outlines problems that may occur when using the 3M Dynapro ET 350 monitor and suggests solution strategies. If problems persist after following the applicable instructions in this chapter, contact 3M Touch Systems technical support (see page 3).

### General problems

Problem	Solution
Video image is unsatisfactory.	<ul style="list-style-type: none"><li>• Adjust display settings (see page 19).</li><li>• Try reducing the refresh rate of your graphic card's output.</li><li>• For monitors with KVM extender option:<ul style="list-style-type: none"><li>• Adjust focus and/or brightness dials on the remote unit of the KVM extender.</li><li>• Consider adjusting KVM extender cable-length jumpers (see page 57).</li><li>• Refer to the "video" section of the troubleshooting chapter in the KVM extender manufacturer's manual.*</li></ul></li></ul>
No video image.	<ul style="list-style-type: none"><li>• Make sure that the monitor is powered up. Listen for the sound of a fan.</li><li>• Check the video extension cables (and, for units with the KVM extender option, check the CAT5 interconnect cable) to be sure that all connectors are properly and securely attached.</li><li>• Make sure that the host computer's monitor resolution is set for no higher than 1024 x 768.</li></ul>

\***Note:** References to "serial device" in the KVM manufacturer's manual denote the "touch screen" of the ET 350 monitor.

Problem	Solution
ET 350 monitor does not power up when plugged in.	Try the following: <ol style="list-style-type: none"> <li>1. Make sure that the power to the monitor's power cable is turned on.</li> <li>2. Make sure that the power to the host computer's power supply is turned on.</li> <li>3. Check that the power cord is properly connected at both ends.</li> <li>4. Check the fuse (see "Replacing the fuse" on page 32).</li> <li>5. Plug the power cable back into the monitor and restore power to the cable.</li> </ol>
After manually aligning the TouchSurround buttons, alignment of the touch screen is unsatisfactory.	<ul style="list-style-type: none"> <li>• Try downloading the standard TouchSurround button definition file (see "Importing standard TouchSurround definitions" on page 24) and then customize the button definition files as required. For instructions on customizing, refer to the appropriate software guide (see "Contacting 3M Touch Systems" on page 3).</li> </ul>
Touch screen not functioning.	<ul style="list-style-type: none"> <li>• Make sure that the touch drivers are installed properly.</li> <li>• Read the touch screen driver error messages (below) and follow the applicable instructions.</li> </ul>
Keyboard/mouse not functioning for the ET 350 monitor with KVM extender option.	<ul style="list-style-type: none"> <li>• Refer to the "keyboard/mouse" section of the troubleshooting chapter in the KVM extender manufacturer's manual.*</li> </ul>

---

**\*Note:** References to "serial device" in the KVM manufacturer's manual denote the "touch screen" of the ET 350 monitor.

---



## Touch screen driver error messages

The touch screen drivers can detect error conditions that are independent of the operating system. If you see one of the following error messages, please note the number displayed with it. This will help 3M Touch Systems technical support staff to diagnose the problem (see page 3).

Error message	Solution
9002: Unable to communicate with touch controller. Check COM port settings and cabling.	<ol style="list-style-type: none"> <li>1. Disconnect power to the controller.</li> <li>2. Double-check all connections between the controller and the host computer.</li> <li>3. Re-connect power to the controller.</li> <li>4. Double-check COM port settings for all peripheral devices and the controller.</li> <li>5. Ensure no other touch drivers are loaded.</li> <li>6. If the error message persists, call 3M Touch Systems for assistance.</li> </ol>
91xx: Touch controller image error detected.	<ul style="list-style-type: none"> <li>• When turning on the MicroTouch NFI touch screen system, make sure that nothing is touching the touch screen or bezel.</li> <li>• If error persists after power-cycling with a clean, untouched screen: <ul style="list-style-type: none"> <li>• There may be short circuits to the touch controller or screen.</li> <li>• The touch screen connector may be loose.</li> <li>• The touch screen or controller may need servicing.</li> </ul> </li> <li>• Double-check all connections between the controller and the host computer.</li> <li>• If the error message persists, call 3M Touch Systems for assistance.</li> </ul>
91xx: Unrecoverable EEPROM failure detected in touch controller. Touch screen is inoperable. Servicing is required.	<ul style="list-style-type: none"> <li>• Controller requires servicing. Call 3M Touch Systems for assistance.</li> </ul>
91xx: Touch controller failed RAM or ROM test. Touch screen is inoperable. Servicing is required.	<ul style="list-style-type: none"> <li>• Controller requires servicing. Call 3M Touch Systems for assistance.</li> </ul>



# APPENDIX A

## Specifications

### Enclosure and cutout dimensions

	Imperial	Metric
<b>Enclosure</b>	14.00" high × 16.30" wide × 6.32" deep	355.60 mm high × 414.02 mm wide × 160.53 mm deep
<b>Panel cutout</b>	12.33" high × 14.36" wide	313.18 mm high × 364.74 mm wide
<b>Mounting clearances</b>	Rear 1"	Rear 25.4 mm
<b>Weight</b>	Standard: 20.5 lb. With KVM extender: 21.3 lb	Standard: 9.3 kg With KVM extender: 9.7 kg

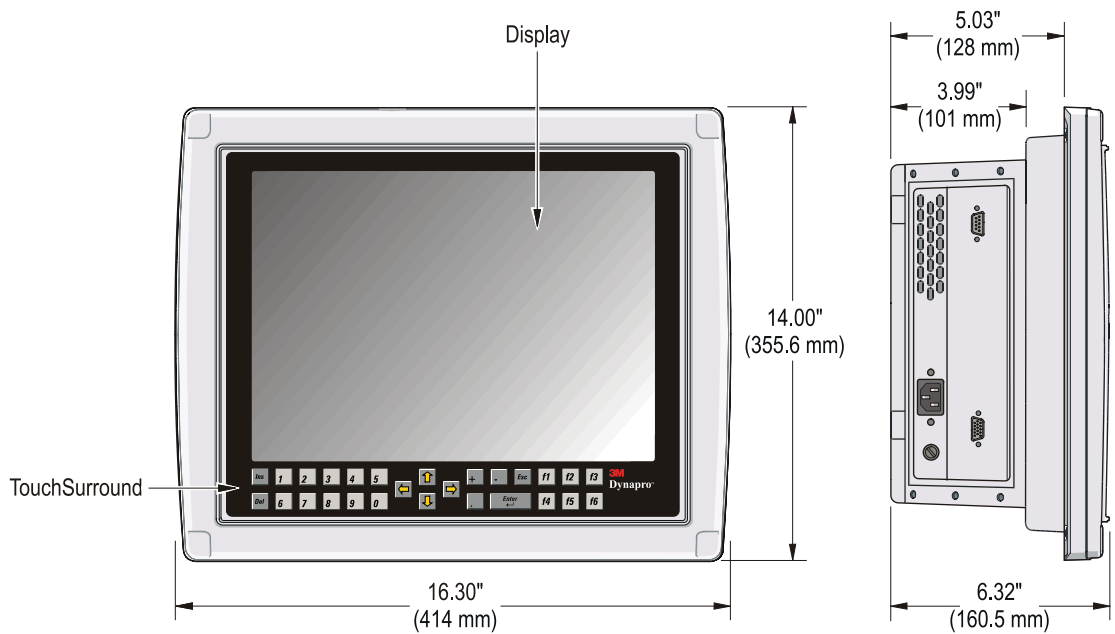
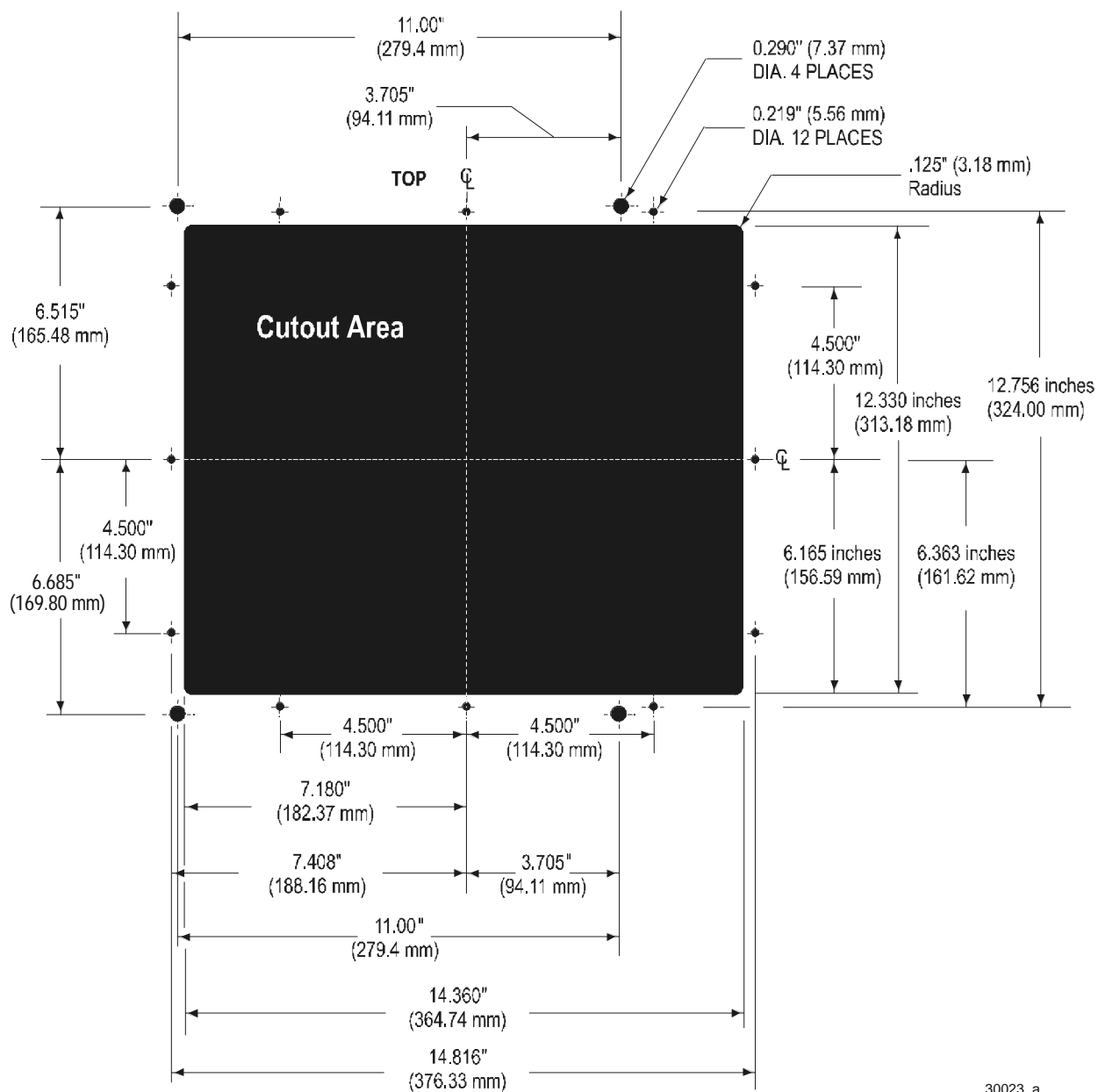

Figure 20: Enclosure dimensions

32504



30023 a

Figure 21: Cutout dimensions

## Display specifications

<b>Viewing area</b>	11.97" (304.1 mm) horizontal 8.98" (228.1 mm) vertical 15" (381 mm) diagonal
<b>Pixel format</b>	1024 (horizontal)× 768 (vertical)
<b>Type</b>	Active Color TFT
<b>Panel colors (up to)</b>	16.7M
<b>Contrast ratio</b>	300:1 (typical)
<b>Viewing angle (typical)</b>	H ± 65° V +50° to -60°
<b>Backlights</b>	4 CCFL
<b>Backlight life expectancy</b>	35,000 hr (typical)
<b>Brightness (typical)</b>	250 cd/m <sup>2</sup> (typical)

## Display modes

Mode	Resolution	VESA	Horizontal frequency (kHz)	Vertical frequency (Hz)	Pixel clock (MHz)
<b>VGA</b>	640 × 480	640 × 480	43.27	85.0	36.000
<b>SVGA</b>	800 × 600	800 × 600	53.67	85.1	56.250
<b>XGA</b>	1024 × 768	1024 × 768	68.67	85.0	94.500

## Chemical resistance

The bezel provides resistance to user abuse and to most chemicals and other substances. Contact 3M Touch Systems technical support for guidelines on protecting the equipment from specific chemicals.

## Supported operating systems

- Windows XP Professional operating system
- Windows 2000 Professional operating system
- Windows NT 4.0 operating system
- Windows 98 operating system
- Windows 95 operating system

## Communications

	Port/ connector	Description
<b>Standard monitor</b>	Serial	<ul style="list-style-type: none"> <li>▪ Touch screen interface to host computer</li> <li>▪ RS-232C compatible asynchronous serial port</li> <li>▪ 9-pin female D-connector</li> </ul>
	VGA	<ul style="list-style-type: none"> <li>▪ Video interface to host</li> <li>▪ VGA signal cable port</li> <li>▪ 15-pin female VGA connector</li> <li>▪ Analog RGB 0.7V p-p</li> <li>▪ TTL level SYNC</li> </ul>
<b>Monitor with KVM extender</b>	CAT5	<ul style="list-style-type: none"> <li>▪ Interconnection between KVM remote and local units</li> </ul>
	Mouse and keyboard	<ul style="list-style-type: none"> <li>▪ Two 6-pin mini-DIN female connectors for keyboard and mouse output to computer</li> </ul>

## Fuses

	Type	Suggested manufacturers
<b>AC power units</b>	1.0 A 250 VAC Type T	Littelfuse 215.001 Schurter 0001.2504 Wickman 1811100000
<b>DC power units</b>	4A 250V, Type T	Bussmann GDC-4A Littelfuse 218004

## AC power supply

<b>AC power source</b>	IEC connector or 3 terminal strip
<b>Input range</b>	115/230 VAC autoranging
<b>Frequency</b>	50/60 Hz
<b>Input current</b>	0.6A @ 115 VAC 0.6A @ 230 VAC

## DC power supply

<b>DC power source</b>	3 terminal strip
<b>DC power input</b>	22-28 VDC (typically 24 VDC)
<b>DC input current</b>	2A

**Operating conditions**

Condition	Range
<b>Operating temperature</b>	0°C to 50°C (32°F to 122°F)
<b>Humidity</b>	50°C, 5% to 95% non-condensing
<b>Maximum operating altitude</b>	6,560 feet (2,000 meters)
<b>Vibration</b>	5 to 57 Hz 0.006 in peak displacement 58 to 2000 Hz 1.0 G acceleration
<b>Shock</b>	Acceleration: 15 G Pulse duration: 11 ms

**Non-operating conditions**

Condition	Range
<b>Storage temperature</b>	-25°C to 60°C (-13°F to 140°F)
<b>Maximum storage altitude</b>	40,000 feet (12,192 meters)
<b>Vibration</b>	5 to 57 Hz 0.015 in peak displacement 58 to 2000 Hz 2.5 G acceleration
<b>Shock</b>	Acceleration: 30G Pulse duration: 11 ms

**Safety standards**

<b>UL 60950 (3rd edition) EN 60950</b>	for Information Technology Equipment
<b>CSA C22.2 No. 950-1995</b>	for Information Technology Equipment via UL's C-UL certification

**Dust and moisture resistance**

<b>NEMA 250</b>	Electrical Enclosures, Type 12, Type 4, Type 4X
<b>IEC 529</b>	Degrees of Protection Provided by Enclosures, IP66

## FCC compliance

This equipment has been tested and found to comply with the limits for a Class A digital device, pursuant to Part 15 of the FCC Rules. These limits are designed to provide a reasonable protection against harmful interference when the equipment is operated in a commercial environment. This equipment generates, uses, and can radiate radio frequency energy, and if installed and used in accordance with the instruction manual, may cause interference to radio communications. Operation of this equipment in a residential area is likely to cause harmful interference, in which case the user will be required to correct the interference at his own expense.

## CE and EMC emissions compliance

This is a Class A product. In a domestic environment this product may cause radio interference, in which case the user may be required to take adequate measures.

- The ET 350 monitor complies with the CE mark related to the Low Voltage Directive 73/23/EEC as confirmed in the Declaration of Conformity.
- The ET 350 monitor complies with the CE mark related to the EMC Directive 89/336/EEC as confirmed in the Declaration of Conformity.

## Canadian emissions compliance

- This Class A digital apparatus meets all requirements of the Canadian Interference-Causing Equipment Regulations.

Cet appareil numérique de la classe A respecte toutes les exigences due Reglement sur le material brouilleur du Canada.

## Electromagnetic compatibility immunity standards

<b>Electromagnetic compatibility immunity standards</b>	EN61000-6-2
<b>ITE immunity</b>	EN55024
<b>Electrostatic discharge</b>	EN61000-4-2
<b>Radiated immunity</b>	EN61000-4-3
<b>Electrical fast transient</b>	EN61000-4-4
<b>Surge transient</b>	EN61000-4-5
<b>Conducted immunity</b>	EN61000-4-6
<b>AC sags and dropouts</b>	EN61000-4-11



## Electromagnetic emission standards

---

EN55022 Class A

---

ICES-003 Class A

---

FCC CFR 47, Part 15, Subpart B, Class A

---

C-Tick — Australia, New Zealand

---

## Product certifications

---

UL Information Technology Equipment — United States

- ET 350R monitor (with panel gasket)
  - UL recognized component for Pollution Degree 3 environments if installed and tested with panel gasket in an enclosure that meets NEMA 4X/IP66 rating.
  - UL recognized for Pollution Degree 2 environments if not mounted or if mounted without the supplied gasket.
- ET 350L2 monitor (without hatch and without panel gasket)
  - UL listed for Pollution Degree 2 environments.
- ET 350L3 monitor (with NEMA 4X hatch)
  - UL listed for Pollution Degree 3 environments.

---

C-UL Information Technology Equipment — Canada

---

CE Information Technology Equipment — Europe

---

## System software

---

Touch screen drivers emulate Microsoft mouse driver.

---

Utility to configure TouchSurround emulates 101-key enhanced PC-compatible keyboard.

---



## APPENDIX B

# Installing monitor with KVM extender

### About this appendix

This appendix provides instructions for installing the ET 350 monitor with the keyboard, video, and mouse (KVM) extender option. For more information about the KVM extender, refer to the manufacturer's manual that came with your ET 350 monitor.

The KVM extender option allows the monitor to be located up to 1000 feet (300 meters) from the host computer. The KVM extender has a local unit and a remote unit. The remote unit is built into the housing of the monitor.

### Step 1: Check and set KVM settings

#### Cable-length jumpers

There are three cable-length jumpers on the remote unit of the KVM extender's circuit board, inside the monitor's enclosure (Figure 22).

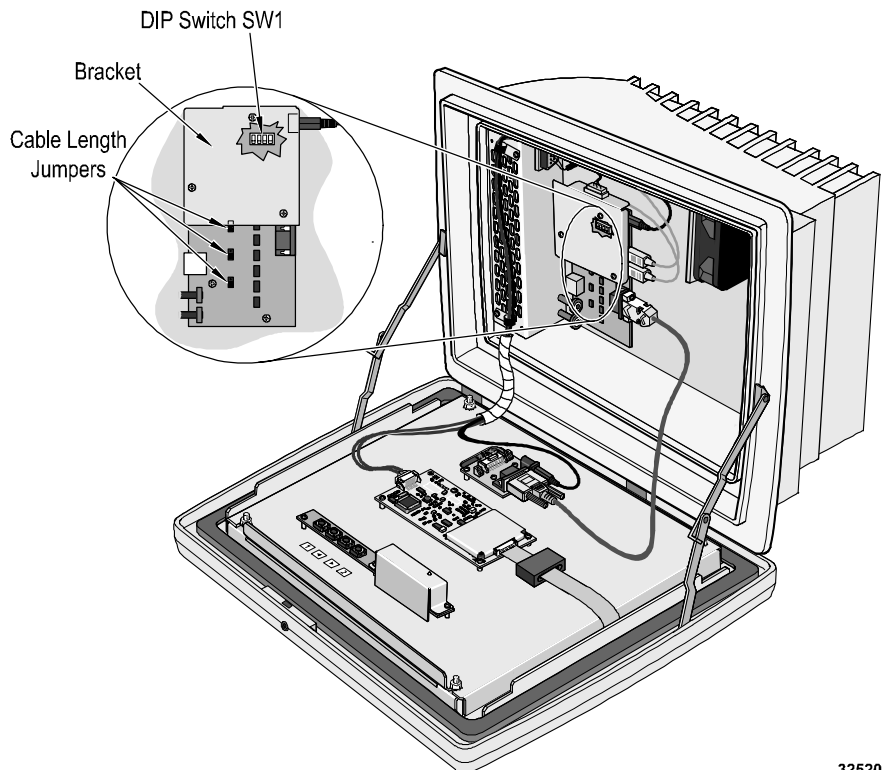

32520

Figure 22: Enclosure of ET 350 monitor with KVM extender

These jumpers (JP3, JP4, and JP5) can be set to adjust equalization of the monitor's display to compensate for loss of image quality due to the signal passing through a long cable.

---

**Important**

If the length of the cable running between the local and remote units is 655 to 1000 feet (200 to 300 meters), which is the default setting for the ET 350 monitor, the jumpers should not need adjusting.

---

To set the cable-length jumpers:

1. Put on an ESD grounding wrist strap.

---

**Important**

To prevent damage from electrostatic discharge (ESD), wear a grounding wrist strap when working with electronic components inside the enclosure. Follow the instructions that come with the wrist strap. If a grounding wrist strap is not available, touch a grounded metal object to discharge any static from your body.

---

2. Disconnect power from the ET 350 monitor.
3. Determine the length of cable between KVM local and remote units.
4. Set the cable-length jumpers as follows:

**If the cable is this length**                      **Set the three cable-length jumpers like this**

655 to 1000 feet  
(200 to 300 meters)



Default setting for ET 350 monitor.

---

330 to 655 feet  
(100 to 200 meters)



---

0 to 330 feet  
(0 to 100 meters)



Off

---

If the length of cable between the local and remote units is near the high end of one of the ranges and you are using high-resolution video (1024 x 768), try setting jumpers for the next higher cable length. This might help improve video compensation.

5. To fine-tune the display image after setting the jumpers, adjust the Brightness and Focus rotary controls. The controls are on the KVM remote unit inside the hatch of the ET 350 monitor (see Figure 23 on page 61).

## Keyboard and mouse control

The ET 350 monitor DIP-Switch SW1 on the KVM extender board is set to *off* (see Figure 22). With this setting, the monitor user can take control by pressing a key on the keyboard or by moving the mouse.

---

### Important

The DIP-Switch default setting for the ET 350 is *off*. This is different from the default setting that appears in the KVM extender manufacturer's manual.

---

If you prefer that users not be able to take control simply by typing on the keyboard, the DIP-Switch will need to be switched to the *on* position.

To change the DIP-Switch setting:

1. Put on an electrostatic discharge (ESD) grounding wrist strap.

---

### Important

To prevent damage from electrostatic discharge (ESD), wear a grounding wrist strap when working with electronic components inside the enclosure. Follow the instructions that come with the wrist strap. If a grounding wrist strap is not available, touch a grounded metal object to discharge any static from your body.

---

2. Make sure that the monitor and host computer are powered off.
3. Open the monitor enclosure.
  - If your unit has security screws on the back of the bezel, remove them with a security screwdriver (the locations of the security screws are shown in Figure 13 on page 38).
  - Apply a 5/32-inch (4 mm) Allen key to the latch screw on the top of the enclosure. Turn the key counterclockwise ¼ turn, or until you feel the unit opening.
4. Find the bracket covering the main circuit board of the remote KVM extender unit (see Figure 22 on page 57).
5. Remove the three screws holding the bracket.

6. Remove the bracket, find the DIP-Switch on the board, and move the switch to the *on* position.
7. Replace the bracket and screws and close the enclosure.

## Step 2: Make connections

To connect communications cables, follow these steps:

1. **If the monitor has a hatch**, the hatch must be open to access connectors. Remove the four #6-32 Phillips screws affixing the hatch to the monitor and open the hatch cover. For an illustration of the locations of these screws, refer to Figure 13 on page 38.
2. Make sure that the monitor and host computer are powered off.
3. Connect one end of the combination keyboard, video, and mouse cable to the local unit of the KVM extender and the multiple connectors on the other end of the cable to the corresponding connectors on the host computer.
4. Connect the serial cable between the KVM local unit and the host computer.

---

### Important

To help ensure optimal performance and to reduce the effect of interference, route the CAT5 cable away from generators, motors, compressors, fluorescent lights, and other cables.

---

5. Interconnect the remote unit (in the ET 350 monitor enclosure) and the local unit of the KVM extender using industry-standard structured cabling (Category 5 UTP or STP, 4-pair) terminated with RJ-45 male connectors. The appropriate connectors on the remote and local units are labelled CAT5 (Figure 23). For information on pinning/pairing the interconnecting cable, refer to Appendix C.

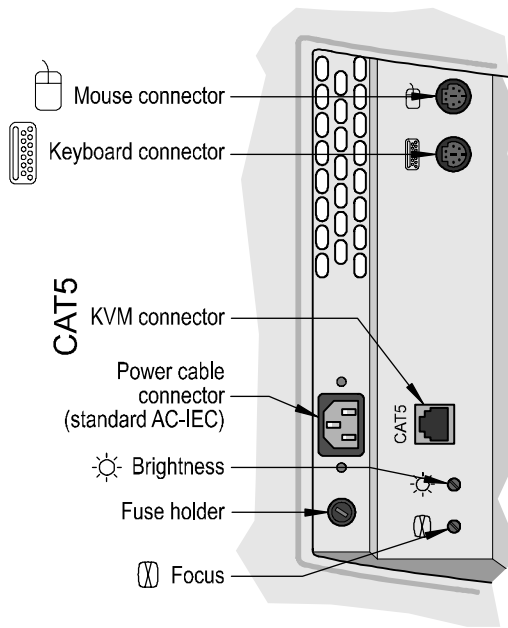

32501a

Figure 23: Connectors: ET 350 monitor with KVM extender

## Remaining steps

Continue the installation steps in Chapter 2, beginning with Step 3 on page 16:

- “Step 3: Connect to power supply
- “Step 4: Adjust display settings
- “Step 5: Install software and import TouchSurround files
- “Step 6: Set ‘backlights saver’ and ‘safe touch’”
- “Step 6: Set “backlights saver” and “safe touch”
- “Step 7: Close enclosure and hatch
- “Step 8: Mount monitor





## APPENDIX C

# Connector pin-outs

### Video signal cable connector

Pin	Signal
1	Red video
2	Green video
3	Blue video
4	N.C.*
5	Vertical sync. return
6	Red return
7	Green return
8	Blue return
9	N.C.*
10	Horizontal sync. return
11	N.C.*
12	N.C.*
13	Horizontal sync.
14	Vertical sync.
15	N.C.*

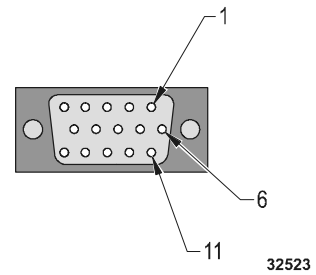

**Important:** To reduce the risk of voiding FCC and CE compliance and reducing the performance of the ET 350 monitor, when making your own cable, reduce the sensitivity of the ET 350 monitor to electrical and radio frequency noise by connecting the cable shield to the connector shield (360 degree shield) on both ends of the cable.

\*N.C. = No Connection

## Serial port RS-232C connector

Pin	Signal	Description	In/Out
1	DCD	N.C.*	
2	RXD	Receive Data	OUT
3	TXD	Transmit Data	IN
4	DTR	Data Terminal Ready	IN
5	SGND	Signal Ground	---
6	DSR	N.C.*	
7	RTS	N.C.*	
8	CTS	N.C.*	
9	RI	N.C.*	

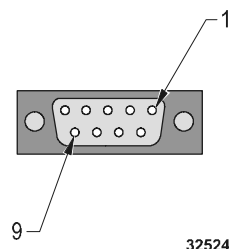

**Important:** To reduce the risk of voiding FCC and CE compliance and reducing the performance of the ET 350 monitor, when making your own cable, reduce the sensitivity of the ET 350 monitor to electrical and radio frequency noise by connecting the cable shield to the connector shield (360 degree shield) on both ends of the cable.

\*N.C. = No Connection

## CAT 5 interconnecting cable (for KVM extender)

Pin	Color	Function, pair
1*	White/Orange	TX, Pair 2
2	Orange/White	RX, Pair 2
3	White/Green	TX, Pair 3
4	Blue/White	RX, Pair 1
5	White/Blue	TX, Pair 1
6	Green/White	RX, Pair 3
7	White/Brown	TX, Pair 4
8*	Brown/White	RX, Pair 4

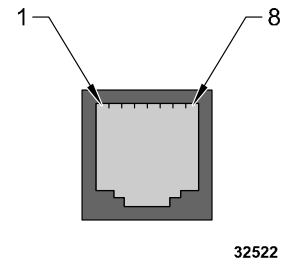

\*Looking into the interconnect socket on either the remote or local unit, or looking at the cable from behind, Pin 1 should be on the left and Pin 8 on the right.

**Important:** To reduce the risk of voiding FCC and CE compliance and reducing the performance of the ET 350 monitor, when making your own cable, reduce the sensitivity of the ET 350 monitor to electrical and radio frequency noise by connecting the cable shield to the connector shield (360 degree shield) on both ends of the cable.

## Keyboard and mouse (for KVM extender)

---

Pin	Signal
1	Data
2	N.C.*
3	GND
4	+5V
5	Clock
6	N.C.*

---

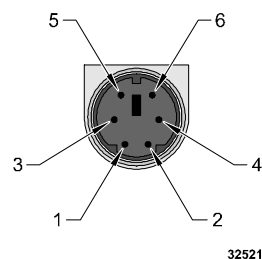

**Important:** To reduce the risk of voiding FCC and CE compliance and reducing the performance of the ET 350 monitor, when making your own cable, reduce the sensitivity of the ET 350 monitor to electrical and radio frequency noise by connecting the cable shield to the connector shield (360 degree shield) on both ends of the cable.

\*N.C. = No Connection

---

# Index

## A

- AC power supply
  - fixed field wiring ■ 17
  - specifications ■ 52
  - standard wiring ■ 16
- ACPI
  - defined ■ 2

## B

- Backlights ■ 7
  - replacing ■ 32
  - safe touch setting ■ 25
  - setting saver ■ 25
  - specifications ■ 51
- Bezel
  - defined ■ 2
  - resistance to chemicals ■ 51
- Boom mount kit (option) ■ 28

## C

- Cable-length jumpers (KVM extender), setting ■ 57
- CAT5 cable (KVM extender)
  - connecting ■ 60
  - pin-outs ■ 65
- CE and EMC emissions compliance ■ 54
- Certifications ■ 55
- Chemical resistance of bezel ■ 51
- Cleaning
  - enclosure ■ 32
  - gaskets ■ 33
  - Moisture Deflector ■ 34
  - touch screen ■ 31
- Closing enclosure ■ 28
- Communications specifications ■ 52
- Connecting
  - CAT5 cable (KVM extender) ■ 60
  - keyboard, video & mouse (KVM

- extender) ■ 60
- serial cable ■ 15
- video cable ■ 14

- Connector pin-outs
  - see Pin-outs
- Controls for on-screen display settings ■ 20
- Customer support ■ 3
- Cutout dimensions ■ 50

## D

- DC power supply (option)
  - connecting ■ 18
  - specifications ■ 52
- Definitions ■ 2
- Desktop stand kit (option) ■ 28
- Dimensions
  - cutout ■ 50
  - enclosure ■ 49
- DIP-Switch SW1 ■ 59
- Display
  - manufacturer's defaults (resetting) ■ 22
  - modes ■ 51
  - on-screen settings ■ 19
  - specifications ■ 6, 51
- Display area, defined ■ 2
- DPMS (Display Power Management System)
  - and on-screen display options ■ 22
  - and safe touch ■ 27
  - defined ■ 2
- Drivers
  - customizing ■ 25
  - error messages ■ 47
  - for Windows NT/9X operating systems (installing) ■ 23
  - operating systems supported ■ 7
  - specifications ■ 55
  - Windows 2000/XP operating systems (installing) ■ 22
- Dust and moisture resistance ■ 53

## E

- Electromagnetic compatibility
  - immunity standards ■ 54
- Electromagnetic emission standards ■ 55
- Electrostatic discharge (ESD) and electromagnetic susceptibility standards ■ 54
- Enclosure
  - cleaning ■ 32
  - closing ■ 28
  - dimensions ■ 49
  - opening ■ 19
- Error messages
  - touch screen drivers ■ 47
- ET 350 monitor
  - certifications ■ 55
  - installing ■ 13–29
  - intended use ■ i
  - KVM extender ■ 10
  - Moisture Deflector ■ 11
  - mounting ■ 28–29
  - mounting kit options ■ 11–12
  - packing lists ■ 5
  - registering ■ 3
  - returning to 3M Touch Systems ■ 3
  - safety labels ■ iii
  - safety standards ■ 53
  - specifications ■ 49–55
  - standard features ■ 6–7
- ET 350 monitor models. see ET 350R monitor, ET 350L2 monitor, and ET 350L3 monitor
- ET 350L2 monitor
  - features ■ 8
  - packing list ■ 5
- ET 350L3 monitor
  - features ■ 8
  - packing list ■ 6
- ET 350R monitor
  - features ■ 8
  - packing list ■ 5

## F

- FCC compliance ■ 54
- Fuse
  - replacing ■ 32–33
  - specifications ■ 52

## G

- Gaskets, checking & cleaning ■ 33
- Glossary ■ 2
- Graphic underlay
  - creating ■ 36
  - defined ■ 2
  - replacing ■ 37–44

## I

- Importing TouchSurround definition files ■ 24

## J

- Jumpers, setting cable-length (KVM extender) ■ 57–59

## K

- Keyboard & mouse cable (KVM extender)
  - connecting ■ 60
  - pin-outs ■ 66
- Keyboard & mouse control
  - setting DIP-Switch SW1 (KVM extender) ■ 59
- KVM extender
  - connecting keyboard, video & mouse ■ 60
  - defined ■ 2
  - installing ■ 57–61
  - keyboard & mouse control ■ 59
  - packing list ■ 10
  - setting cable-length jumpers ■ 57–59
  - setting keyboard & mouse control ■ 60

## M

- MicroTouch Near Field Imaging (NFI) touch screen, defined ■ 2, 6
- Moisture Deflector
  - cleaning & maintaining ■ 34
  - mounting ■ 29
- Mounting
  - boom mount option ■ 28
  - desktop stand option ■ 28
  - rack mount option ■ 28

## N

- Near Field Imaging (NFI). see  
MicroTouch Near Field Imaging
- Non-operating conditions ■ 53

## O

- On-screen display settings
  - adjusting ■ 19
  - auto display setup ■ 20
  - before manually adjusting ■ 20
  - controls ■ 20
  - OSD menu ■ 22
  - steps ■ 21
  - Utility menu ■ 22
- Opening enclosure ■ 19–20
- Operating conditions ■ 53
- Operating systems supported by  
drivers ■ 7, 51

## P

- Packing list
  - ET 350L2 monitor ■ 5
  - ET 350L3 monitor ■ 6
  - ET 350R monitor ■ 5
  - KVM extender ■ 10
- Pin-outs
  - CAT5 cable (KVM extender) ■ 65
  - keyboard & mouse cable (KVM  
extender) ■ 66
  - serial cable ■ 64
  - video cable ■ 63
- Power supply
  - see AC power supply
  - see DC power supply (option)
- Product certifications ■ 55

## R

- Rack mount kit (option) ■ 28
- Replacing
  - backlights ■ 32

- fuse ■ 32–33
- graphic underlay ■ 37–44

- Resistance to chemicals ■ 51
- Returning ET 350 monitor to 3M Touch  
Systems ■ 3

## S

- Safe touch setting
  - described ■ 25
  - Windows 9X operating system ■ 27
  - Windows XP/2000 operating  
systems ■ 25, 26
- Safety
  - standards ■ 53
- Safety labels
  - defined ■ iii
- Security hardware kit ■ 28
- Serial cable
  - connecting ■ 15
  - pin-outs ■ 64
- Software specifications ■ 55
- Specifications ■ 49–55
  - AC power supply ■ 52
  - communications ■ 52
  - DC power supply ■ 52
  - display ■ 51
  - display modes ■ 51
  - drivers ■ 55
  - dust & moisture resistance ■ 53
  - fuse ■ 52
  - non-operating conditions ■ 53
  - operating conditions ■ 53
- Standards
  - CE and EMC emissions  
compliance ■ 54
  - electromagnetic compatibility  
immunity standards ■ 54
  - electromagnetic emission ■ 55
  - FCC compliance ■ 54
  - safety ■ 53

## T

- Terms ■ 2
- 3M Touch Systems
  - customer support ■ 3
  - returns policy ■ 3
  - trademarks ■ ii
- Touch screen
  - cleaning ■ 31
  - defined ■ 2
- TouchSurround
  - defined ■ 2, 35
  - importing definition files ■ 24
  - replacing underlay ■ 37–44
- TouchSurround. see also Graphic underlay ■ 36
- Trademarks ■ ii
- Troubleshooting ■ 45–47

## V

- Video cable
  - connecting ■ 14
  - pin-outs ■ 63
- Video drivers, downloading latest ■ 15

## W

- Windows 9X operating system
  - backlights saver ■ 25
- Windows NT/9X operating systems
  - installing driver ■ 23
- Windows XP/2000 operating systems
  - installing driver ■ 22
  - safe touch ■ 25
  - setting backlights saver ■ 25
  - setting safe touch ■ 26–27