

***Friedrich***<sup>®</sup>

# Room Air Conditioner Service and Parts Manual

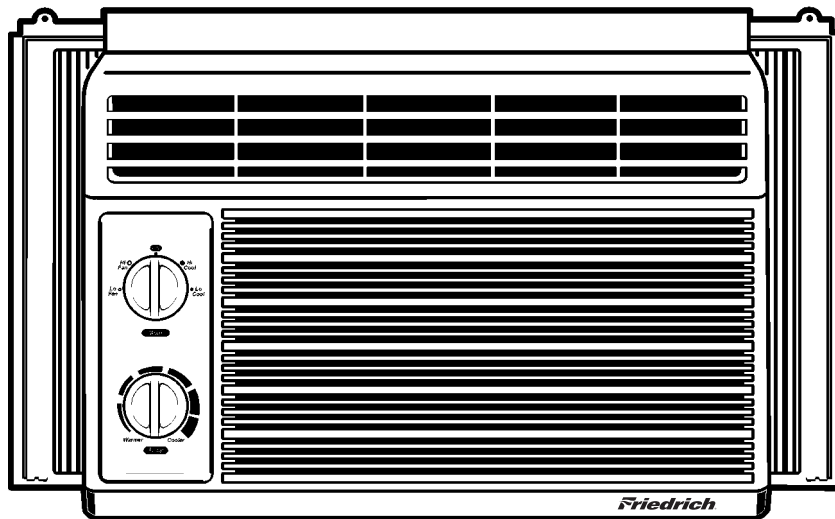

**ZStar<sup>®</sup>**

115Volts

• ZQ05B10

• ZQ07B10

# CONTENTS

<b>1. PREFACE</b> .....	3
1.1 FEATURES.....	3
1.2 SPECIFICATIONS .....	3
1.3 LOCATIONS OF CONTROLS .....	4
1.4 SAFETY PRECAUTIONS .....	4
1.5 INSULATION RESISTANCE TEST .....	4
<b>2. DISASSEMBLY INSTRUCTIONS</b> .....	5
2.1 MECHANICAL PARTS .....	5
2.1.1 FRONT GRILLE .....	5
2.1.2 CABINET.....	5
2.1.3 CONTROL BOARD.....	5
2.2 AIR HANDLING PARTS .....	6
2.2.1 AIR GUIDE UPPER .....	6
2.2.2 ORIFICE, TURBO FAN AND FAN .....	6
2.2.3 MOTOR .....	7
2.2.4 AIR GUIDE .....	7
2.3 ELECTRICAL PARTS .....	7
2.3.1 OVERLOAD PROTECTOR .....	7
2.3.2 COMPRESSOR .....	8
2.3.3 CAPACITOR .....	8
2.3.4 THERMOSTAT .....	8
2.3.5 ROTARY SWITCH.....	8
2.3.6 POWER CORD .....	9
2.4 REFRIGERANT CYCLE .....	9
2.4.1 CONDENSER .....	9
2.4.2 EVAPORATOR .....	10
2.4.3 CAPILLARY TUBE .....	10
<b>3. TROUBLESHOOTING GUIDE</b> .....	12
3.1 OUTSIDE DIMENSIONS... ..	12
3.2 PIPING SYSTEM .....	13
3.3 TROUBLESHOOTING GUIDE .....	14
<b>4. CIRCUIT DIAGRAM</b> .....	19
<b>5. EXPLODED VIEW</b> .....	20
<b>6. SERVICE PARTS LIST</b> .....	21

# 1. PREFACE

This service manual provides various service information, including the mechanical and electrical parts, etc. This room air conditioner was manufactured and assembled under a strict quality control system. The refrigerant is charged at the factory. Be sure to read the safety precautions prior to servicing the unit.

## 1.1 FEATURES

- DESIGNED FOR COOLING ONLY
- POWERFUL AND INCREDIBLE COOLING
- TOP-DOWN CHASSIS FOR THE SIMPLE INSTALLATION AND SERVICE
- BUILT-IN ADJUSTABLE THERMOSTAT
- WASHABLE ONE-TOUCH FILTER
- COMPACT SIZE

## 1.2 SPECIFICATIONS

ITEMS	MODELS	ZQ05B10	ZQ07B10
COOLING CAPACITY (BTU/h)		5,100	6,500
POWER SUPPLY (Phase, V, Hz)		1ø, 115V, 60HZ	
INPUT (W)		540	670
OPERATING CURRENT (AMP.)		5.0	6.1
REFRIGERANT CONTROL		CAPILLARY TUBE	
REFRIGERANT CHARGE (R-22)		325g (7.9 oz)	335g (11.8 oz)
INSIDE FAN		TURBO FAN	
OUTSIDE FAN		PROPELLER FAN WITH SLINGER RING	
AIR DISCHARGE		2-WAY (RIGHT AND LEFT)	
CHASSIS		TOP-DOWN	
PROTECTOR		<ul style="list-style-type: none"> <li>• OVERLOAD PROTECTOR FOR COMPRESSOR</li> <li>• INTERNAL PROTECTOR FOR FAN MOTOR</li> </ul>	
TEMPERATURE CONTROL		THERMISTOR	
FAN MOTOR		6 POLES, 16W	6 POLES, 27W

## 1.3 LOCATIONS OF CONTROLS

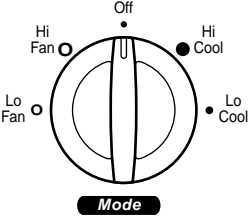
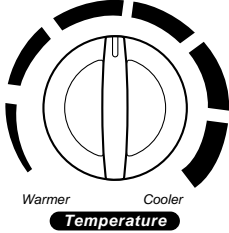
<p style="text-align: center;"><b>Operation</b></p> 	<p>Off : Turns air conditioner off.</p> <p>Hi Fan : High speed fan operation without cooling.</p> <p>Lo Fan : Low speed fan operation without cooling.</p> <p>Hi Cool : Cooling with high speed fan operation.</p> <p>Lo Cool : Cooling with low speed fan operation.</p>
<p style="text-align: center;"><b>Thermostat</b></p> 	<p>This automatically controls the temperature of the indoor air.</p> <p>Turn the knob so that the arrow points to the larger marks for greater cooling. Point the arrow to the smaller marks for more moderate cooling. (i.e. the higher the number, the greater the cooling)</p>

**CAUTION** : After switching the air conditioner from Cool to Off or Fan, wait at least 3 minutes before switching it back to Cool.

## 1.4 SAFETY PRECAUTIONS

1. When servicing, set the ROTARY SWITCH to Off and unplug the power cord.
2. Observe the original lead dress.  
If a short circuit is found, replace all parts which have been overheated or damaged by the short circuit.
3. After servicing, make an insulation resistance test to prevent the customer from being exposed to shock hazards.

## 1.5 INSULATION RESISTANCE TEST

1. Unplug the power cord and connect a jumper between 2 pins (black and white).
2. The grounding conductor (green or green and yellow) is to be open.
3. Measure the resistance value with an ohm meter between the jumpered lead and each exposed metallic part on the equipment at all position [except Off] of the ROTARY SWITCH.
4. The value should be over 1 MΩ.

## 2. DISASSEMBLY INSTRUCTIONS

### 2.1 MECHANICAL PARTS

#### 2.1.1 FRONT GRILLE

1. Disconnect the unit from source of power.
2. Remove the two knobs by pulling them off.  
Using a screwdriver, remove the screw that secures the front grille to control board.  
(See Figure 1)
3. Push the front grille up from the bottom.  
Pull the top of the front grille away from the cabinet as the top tabs lift out of their slots.  
(See Figure 2)
4. Replace the grille by placing the tabs in the slots and push the grille until it snaps into place.

Figure 1

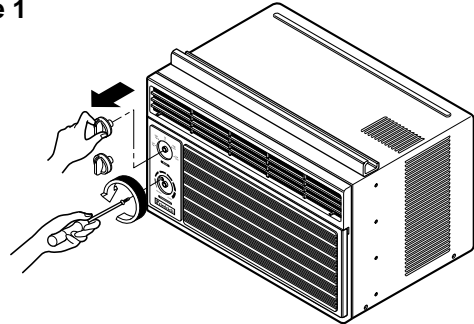
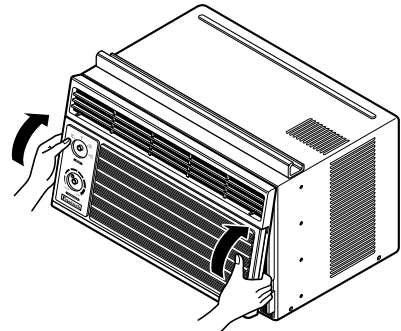

Figure 2



#### 2.1.2 CABINET

1. Disconnect the unit from the power source.
2. Remove the front grille. (Refer to section 2.1.1)
3. Remove 9 screws that secure the cabinet to the base pan and condenser. (See Figure 3)
4. Lift the cabinet from the unit.
5. Re-install by referring to the procedures above.

Figure 3

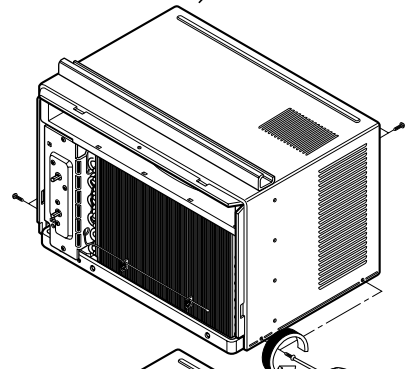

Figure 4

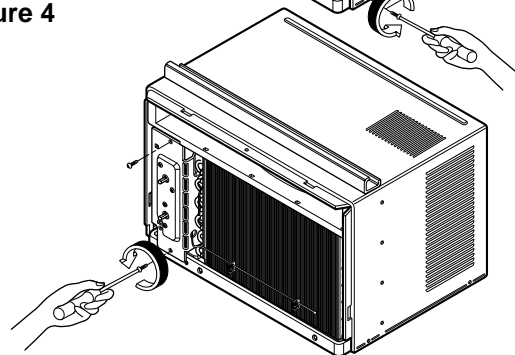
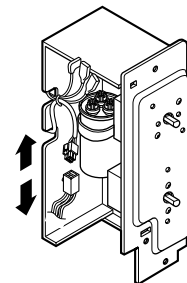

Figure 5



#### 2.1.3 CONTROL PANEL

1. Disconnect the unit from the power source.
2. Remove the front grille. (Refer to Section 2.1.1)
3. Remove the cabinet. (Refer to Section 2.1.2)
4. Remove 2 screws that secure the control board to base pan and air guide. (See Figure 4)
5. Pull the control board toward yourself.

**NOTE :** Controls, wires, and capacitor are now accessible for servicing. Discharge the capacitor before servicing. See step 2.3.3 on page 8 for procedures.

6. Disconnect one housing terminal and 3 wires for the fan motor and compressor. (See Figure 5)
7. Re-install components by referring to procedures above. (Refer to wiring diagram on page 23 in this manual or inside control board.)

## 2.2 AIR HANDLING PARTS

### 2.2.1 AIR GUIDE UPPER

1. Disconnect the unit from the power source.
2. Remove the front grille. (Refer to Section 2.1.1)
3. Remove the cabinet. (Refer to Section 2.1.2)
4. Remove the control panel.  
(Refer to Section 2.1.3)
5. Remove 2 screws that secure the air guide upper to air guide lower. (See Figure 6)
6. Lift air guide upper upward.
7. Re-install by referring to the procedures above.

Figure 6

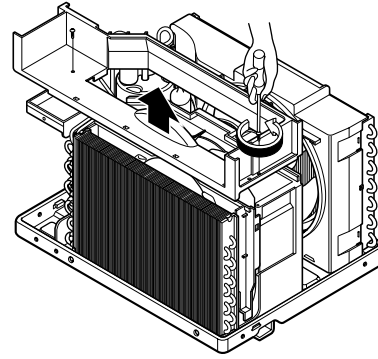

### 2.2.2 ORIFICE, TURBO FAN AND FAN

1. Disconnect the unit from the power source.
2. Remove the front grille. (Refer to Section 2.1.1)
3. Remove the cabinet. (Refer to Section 2.1.2)
4. Remove the control panel  
(Refer to Section 2.1.3)
5. Remove the air guide upper.  
(Refer to Section 2.2.1)
6. Remove 2 screws that secure the base pan to condenser. (See Figure 7)
7. Remove screw that secures the shroud to channel of condenser.
8. Press the snap area of shroud with your thumbs. This allows you to remove it from the condenser.
9. Lift the compressor upward with the evaporator and condenser. (See Figure 7)
10. Remove the orifice by pushing the snap area of the air guide blower. (See Figure 8)
11. Remove the clamp springs which are clamped to the base of fan and turbo fan by hand plier. (See Figure 9)
12. Pull the fan and turbo fan outward.
13. Remove the shroud.
14. Re-install by referring to the procedures above.

Figure 7

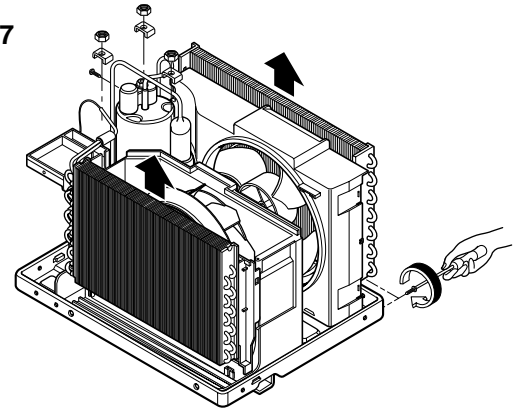

Figure 8

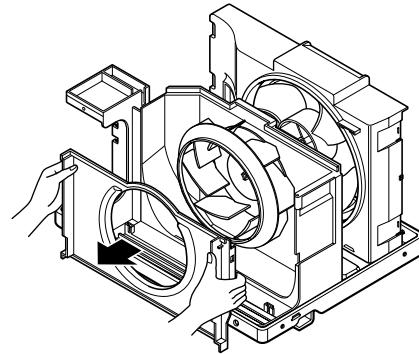
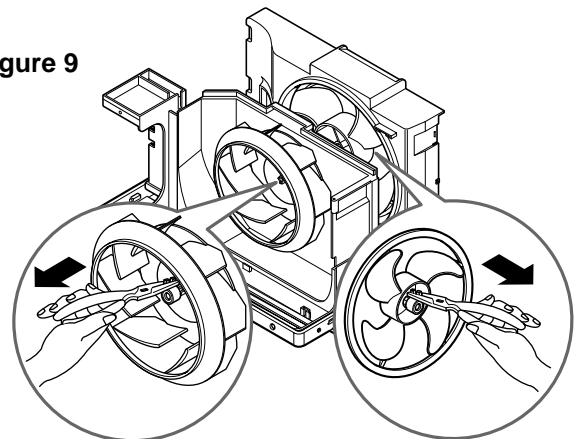

Figure 9



## 2.2.3 MOTOR

1. Disconnect the unit from the power source.
2. Remove the front grille. (Refer to Section 2.1.1)
3. Remove the cabinet. (Refer to Section 2.1.2)
4. Remove the control panel.  
(Refer to Section 2.1.3)
5. Remove the air guide upper.  
(Refer to Section 2.2.1)
6. Remove the compressor, turbo fan, fan and shroud. (Refer to Section 2.2.2)
7. Remove 2 screws that secure the motor to the motor. (See Figure 10)
8. Remove the motor.
9. Re-install by referring to the procedures above.

Figure 10

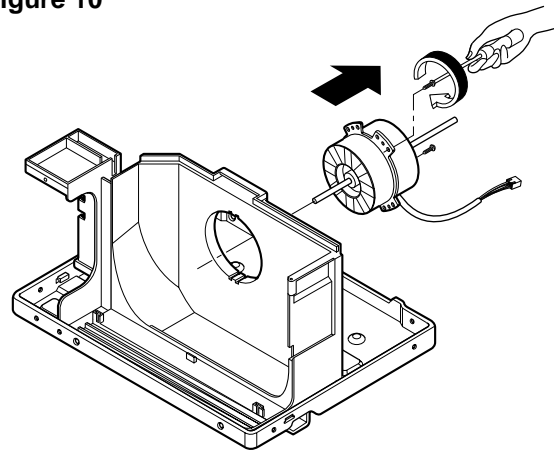

## 2.2.4 AIR GUIDE

1. Disconnect the unit from the power source.
2. Remove the front grille. (Refer to Section 2.1.1)
3. Remove the cabinet. (Refer to Section 2.1.2)
4. Remove the control panel.  
(Refer to Section 2.1.3)
5. Remove the air guide upper.  
(Refer to Section 2.2.1)
6. Remove the compressor, turbo fan, fan and shroud. (Refer to Section 2.2.2)
7. Remove the motor. (Refer to Section 2.2.3)
8. Remove 2 screws that secure the air guide to the base pan. (See Figure 11)
9. Push the air guide backward and lift it upward.  
(See Figure 11)
10. Re-install by referring to the procedures above.

Figure 11

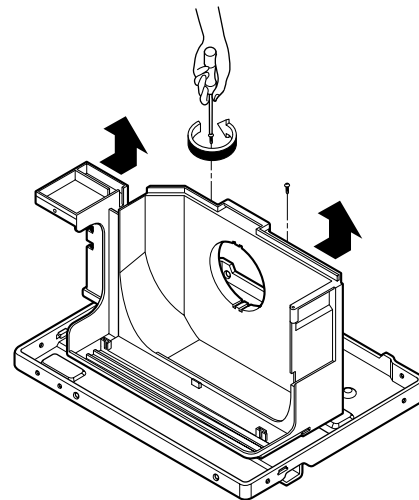

## 2.3 ELECTRICAL PARTS

### 2.3.1 OVERLOAD PROTECTOR

1. Remove the front grille and cabinet.  
(Refer to Section 2.1)
2. Remove the nut which fastens the terminal cover.
3. Remove the terminal cover.
4. Remove all the leads from the overload protector.
5. Remove the overload protector.
6. Re-install the components by referring to the removal procedure above.  
(See Figure 12 and 13)

Figure 12

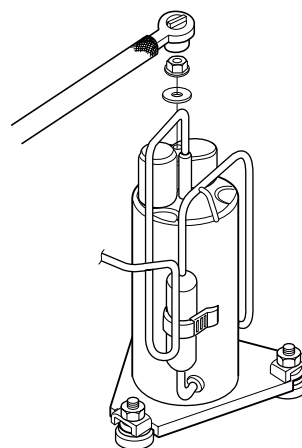
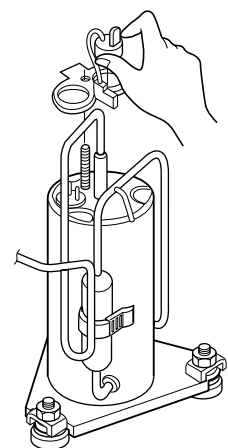

Figure 13



### 2.3.2 COMPRESSOR

1. Remove the front grille and cabinet.  
(Refer to Section 2.1)
2. Discharge the refrigerant by using a refrigerant recovery system.
3. Remove the overload protector.  
(Refer to Section 2.3.1)
4. After discharging the unit completely, unbraid the suction and discharge pipes at the compressor connections.
5. Remove 3 nuts which fasten the compressor.
6. Remove the compressor.
7. Re-install by referring to the removal procedure above. (See Figure 14)

Figure 14

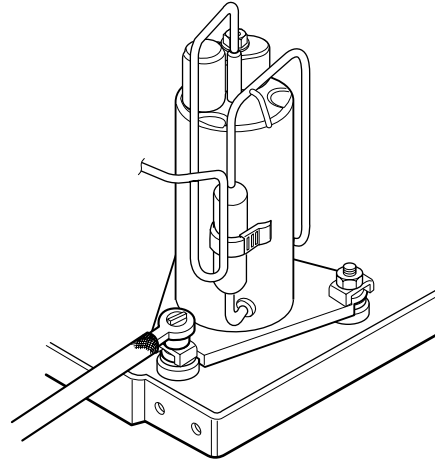

### 2.3.3 CAPACITOR

1. Remove the cabinet. (Refer to Section 2.1.2)
2. Remove the control panel.  
(Refer to Section 2.1.3)
3. Discharge the capacitor by placing a 20 K $\Omega$  resistor across the capacitor terminals.
4. Remove the screw which fastens the capacitor clamp.
5. Remove all the leads of capacitor terminals.
6. Re-install the components by referring to the removal procedure above. (See Figure 15)

Figure 15

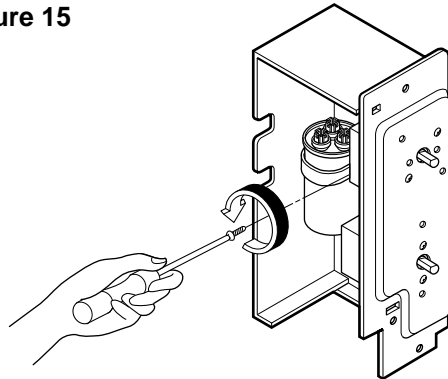

### 2.3.4 THERMOSTAT

1. Remove the cabinet. (Refer to Section 2.1.2)
2. Remove the control panel.  
(Refer to Section 2.1.3)
3. Remove 2 screws which fasten the thermostat.
4. Remove all the leads of the thermostat terminals.
5. Remove the thermostat.
6. Re-install the components by referring to the removal procedure above. (See Figure 16)

Figure 16

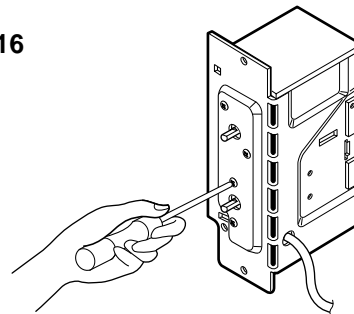

### 2.3.5 ROTARY SWITCH

1. Remove the cabinet. (Refer to Section 2.1.2)
2. Remove the control panel.  
(Refer to Section 2.1.3)
3. Remove 2 screws which fasten the rotary switch.
4. Remove all the leads of the rotary switch terminals.
5. Remove the rotary switch.
6. Re-install the components by referring to the removal procedure above. (See Figure 17)

Figure 17

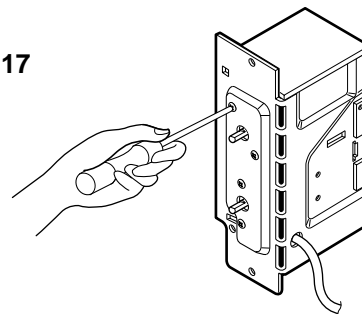



### 2.3.6 POWER CORD

1. Disconnect the unit from source of power.
2. Remove the front grille. (Refer to Section 2.1.1)
3. Remove the cabinet. (Refer to Section 2.1.2)
4. Remove a screw that secures control panel to base pan. (Refer to Section 2.1.3)
5. Pulls the control panel toward you.
6. Disconnect the 2 receptacles and remove the grounding screw.
7. Remove a screw securing the clip with cord to the control board.
8. Pull the power cord.
9. Re-install by referring to procedures above.

Figure 18

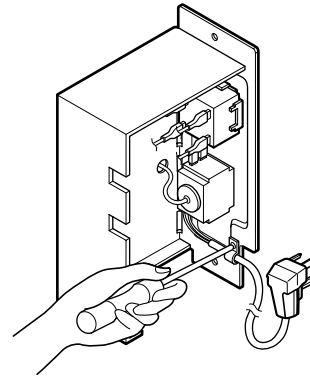

## 2.4 REFRIGERANT CYCLE

### 2.4.1 CONDENSER

1. Remove the cabinet. (Refer to Section 2.1.2)
2. Discharge the refrigerant by using a refrigerant recovery system.
3. Remove the air guide. (Refer to Section 2.2.1)
4. Remove 2 screws which fasten the condenser.
5. After discharging the refrigerant completely, unbraid the interconnecting tube at the condenser connections.
6. Remove the condenser.
7. Re-install by referring to the procedures above.

Figure 19

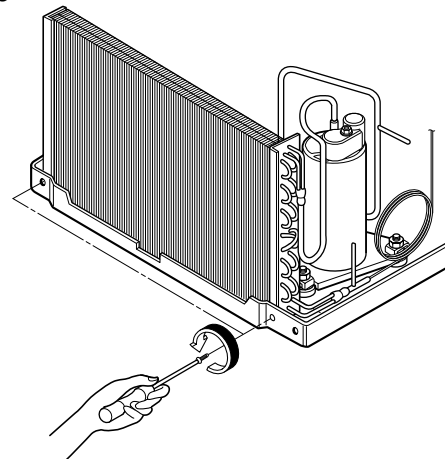

## 2.4.2 EVAPORATOR/CONDENSER

1. Remove the cabinet.
2. Discharge the refrigerant by using a refrigerant recovery system.
3. Remove the air guide upper. (Refer to Section 2.2.1)
4. After discharging the refrigerant completely, unbrazed the interconnecting tube at the proper connections.
5. Remove the proper coil.
6. Re-install by referring to the procedures above.

## 2.4.3 CAPILLARY TUBE

1. Remove the cabinet.
2. Discharge the refrigerant by using a refrigerant recovery system.
3. Remove the air guide upper. (Refer to Section 2.2.1)
4. After discharging the refrigerant completely, unbrazed the interconnecting tube of the capillary tube.
5. Remove the capillary tube.
6. Re-install by referring to the procedures above.

## NOTES

Replacement of the refrigeration cycle.

1. When replacing the refrigeration cycle, be sure to discharge the refrigerant by using a refrigerant recovery system.
2. After discharging the unit completely, remove the desired components, and unbrazed the pinch-off tubes.
3. Solder service valves into the pinch-off tube ports, leaving the valves open.
4. Solder the pinch-off tubes with service valves.
5. After completing the above procedures, the valve must be closed and left in place on the system for any subsequent procedures.
6. Evacuate as follows:
  - 6-1. Connect the vacuum pump, as illustrated in figure 21A.
  - 6-2. Start the vacuum pump. Slowly open manifold valves A and B with two full turns counterclockwise and leave the valves closed. The vacuum pump is now pulling through valves A and B up to valve C by means of manifold and the entire system.

**CAUTION** : If high vacuum equipment is used, just crack valves A and B for a few minutes, then open slowly with the two full turns counterclock-

wise. This will keep oil from foaming and being drawn into the vacuum pump.

- 6-3. Operate the vacuum pump for 20 to 30 minutes, until 600 micron vacuum is obtained. Close valves A and B and observe vacuum gauge for a few minutes. A rise in pressure would indicate a possible leak or moisture remaining in the system. With valves A and B closed, stop the vacuum pump.
- 6-4. Remove the hose from the vacuum pump and place it on the charging cylinder. See figure 21B. Open valve C. Discharge the line at the manifold connection.
- 6-5. The system is now ready for final charging.
7. Recharge as follows:
  - 7-1. Refrigeration cycle systems are charged from the high-side. If the total charge cannot be put in the high-side, the balance will be put in the suction line through the access valve which is installed as the system is opened.
  - 7-2. Connect the charging cylinder as shown in figure 21B. With valve C open, discharge the hose at the manifold connection.
  - 7-3. Open valve A and allow the proper charge to enter the system. Valve B is still closed.
  - 7-4. If more charge is required, the high-side will not take it. Close valve A.
  - 7-5. With the unit running, open valve B and add the balance of the charge.
    - a. Do not add the liquid refrigerant to the low-side.
    - b. Watch the low-side gauge, allow pressure to rise to 30 lbs.
    - c. Turn off valve B and allow the pressure to drop.
    - d. Repeat steps b. and c. until the balance of the charge is in the system.
  - 7-6. When the unit is operating correctly, use the pinch-off tool with the unit still running and clamp on the pinch-off tube. Using a tube cutter, cut the pinch-off tube about 2 inches from the pinch-off . Use sil-fos solder and solder the pinch-off tube closed. Turn off the unit, allow unit to sit for a while and then test the leakage of the pinch-off connection.

**Equipment needed:** Vacuum pump, charging cylinder, manifold gauge, brazing equipment, pinch-off tool capable of making a vapor proof seal, leak detector, tubing cutter, hand tools to remove components and service valve.

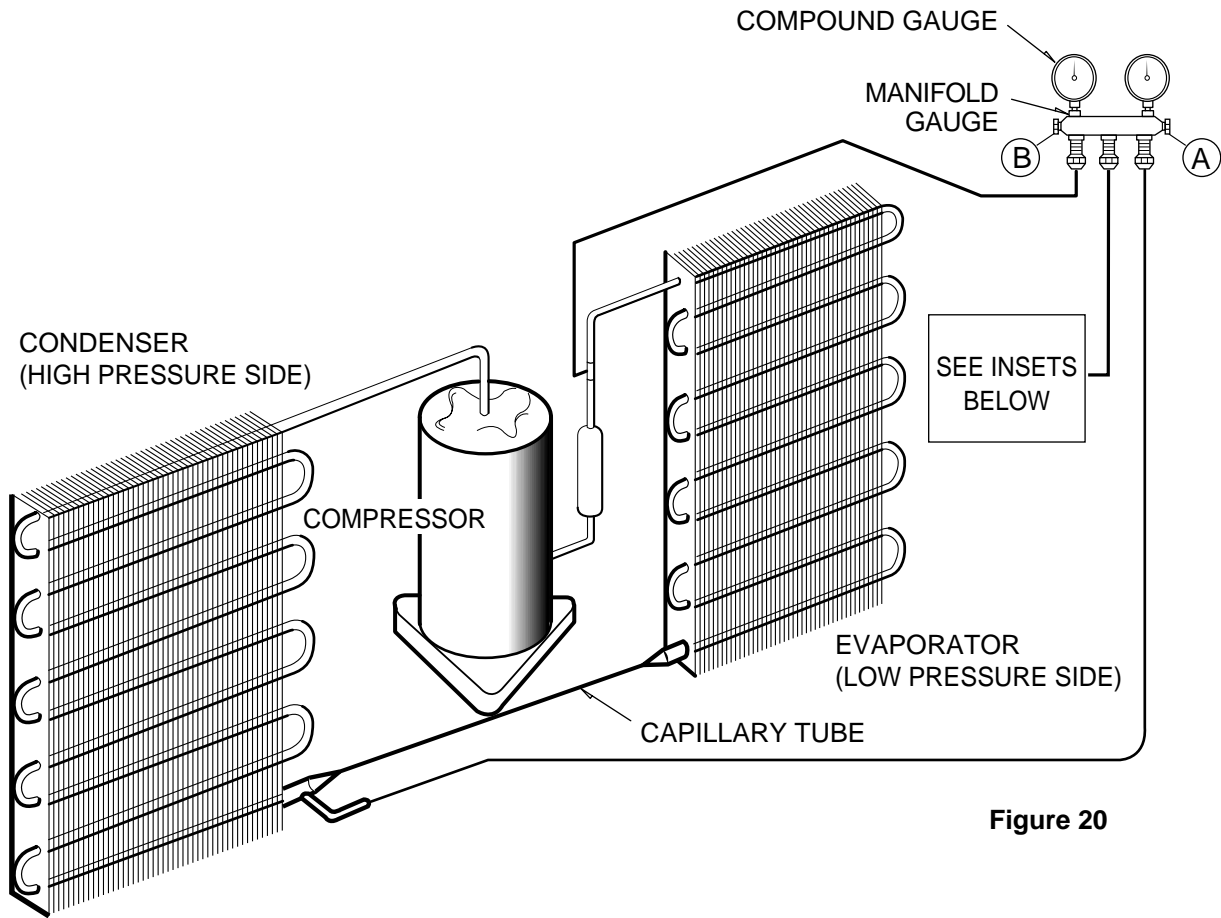

**Figure 20**

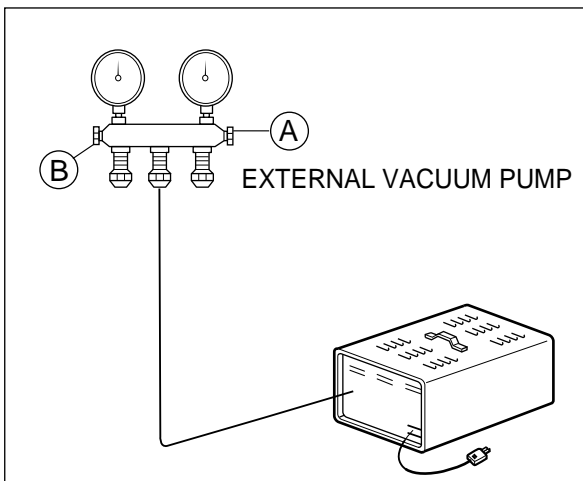

**Figure 21A-Pulling Vacuum**

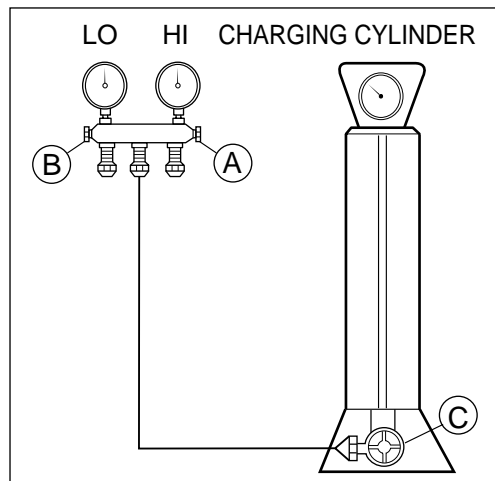

**Figure 21B-Charging**

# 3. TROUBLESHOOTING GUIDE

## 3.1 OUTSIDE DIMENSIONS (unit: mm [in])

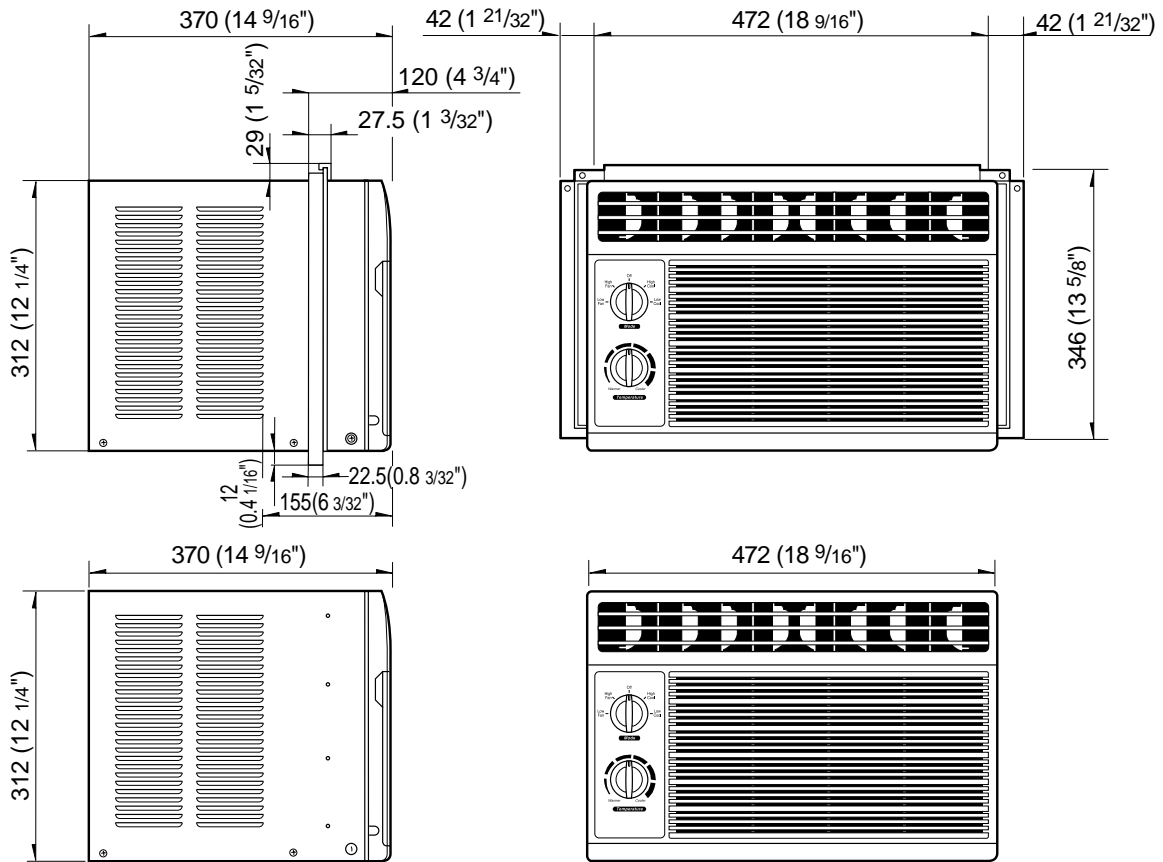

### 3.2 PIPING SYSTEM

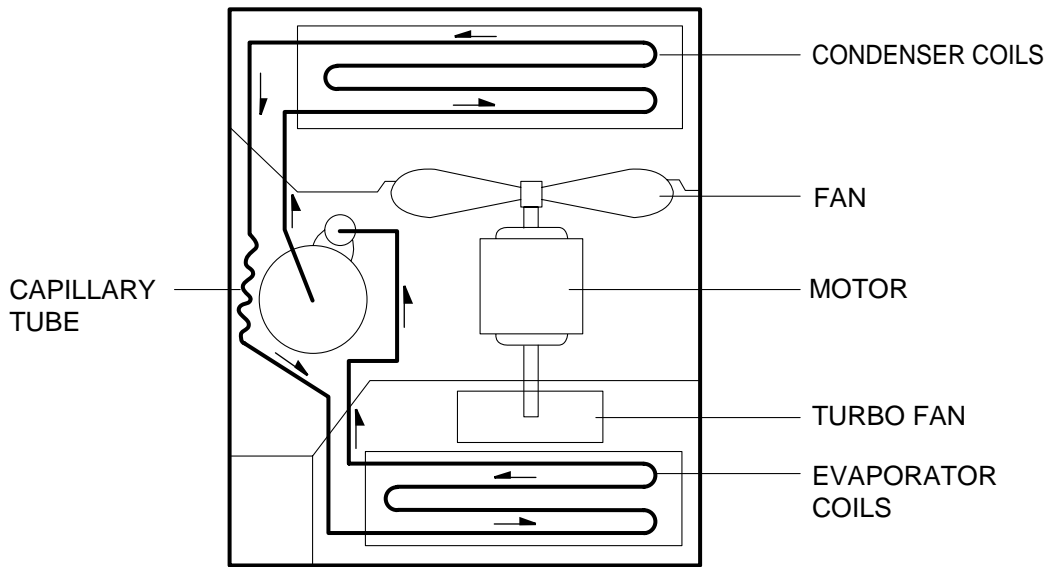
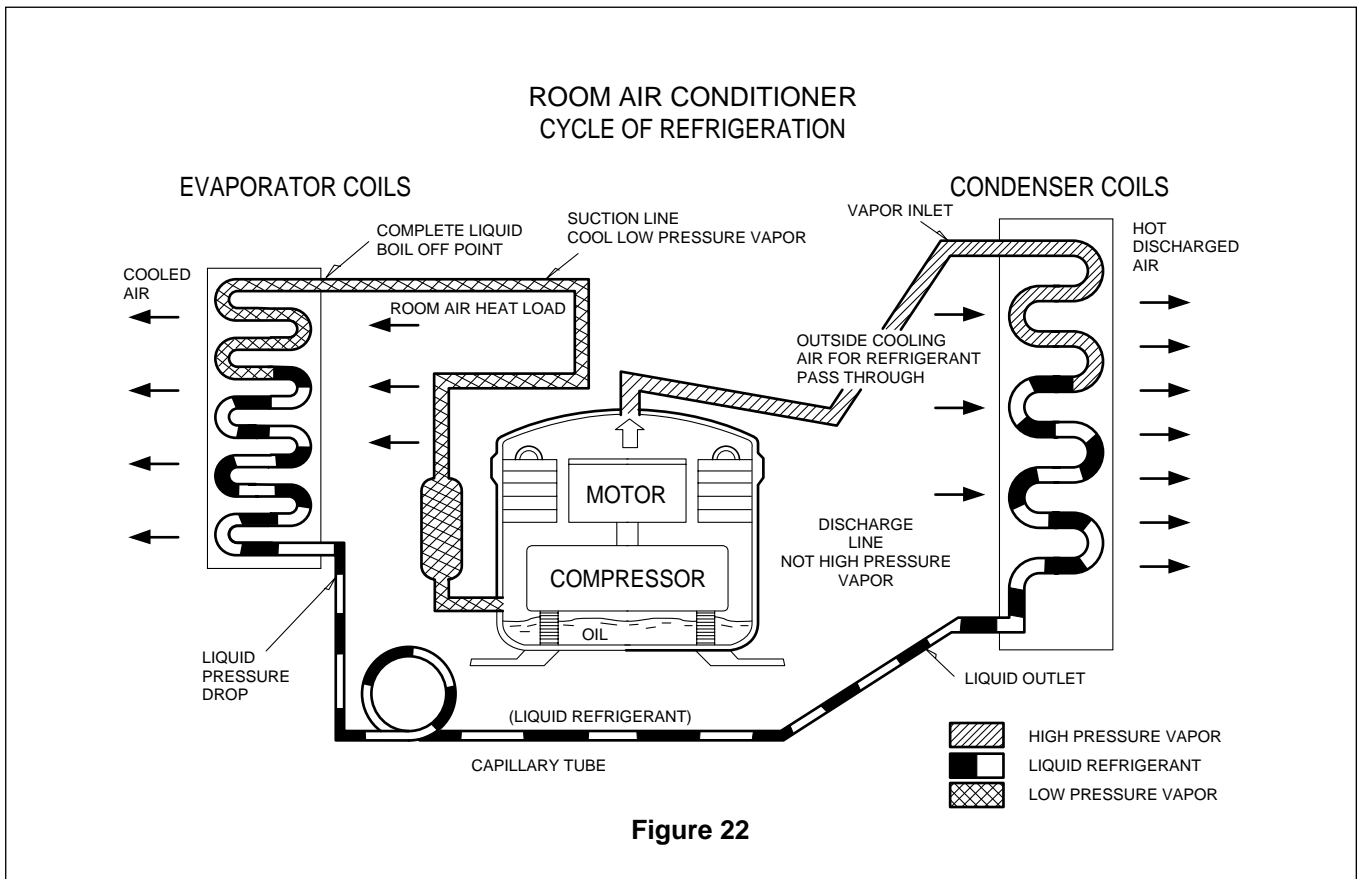

Figure 22 is a brief description of the important components and their function in what is called the refrigeration system. This will help you to understand the refrigeration cycle and the flow of the refrigerant in the cooling cycle.



### 3.3 TROUBLESHOOTING GUIDE

In general, possible trouble is classified in two categories.

The one is called **Starting Failure** which is caused by an electrical defect. The other is **Ineffective Air Conditioning** caused by a defect in the refrigeration circuit and/or improper application.

#### Unit is running but cooling is ineffective.

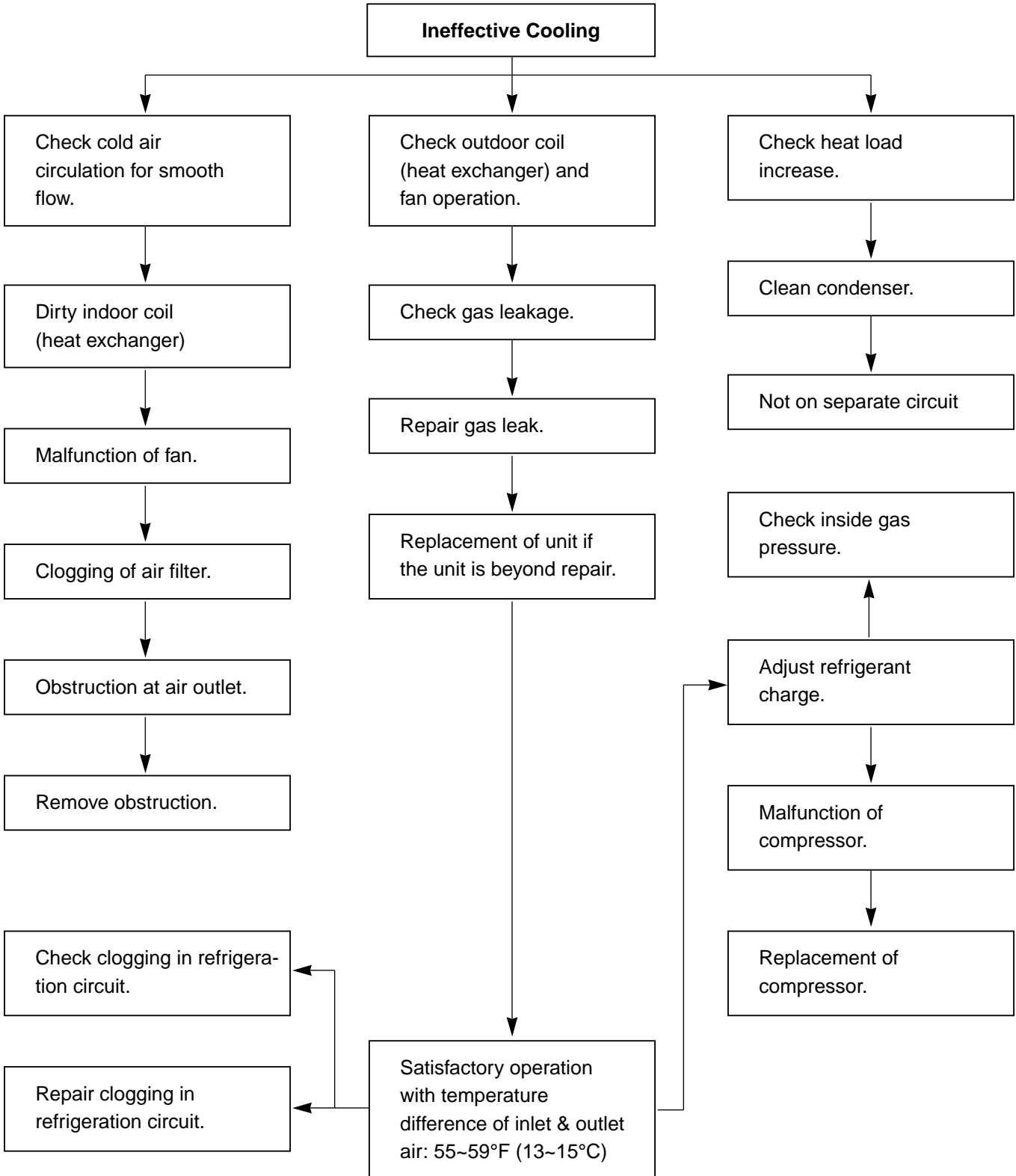

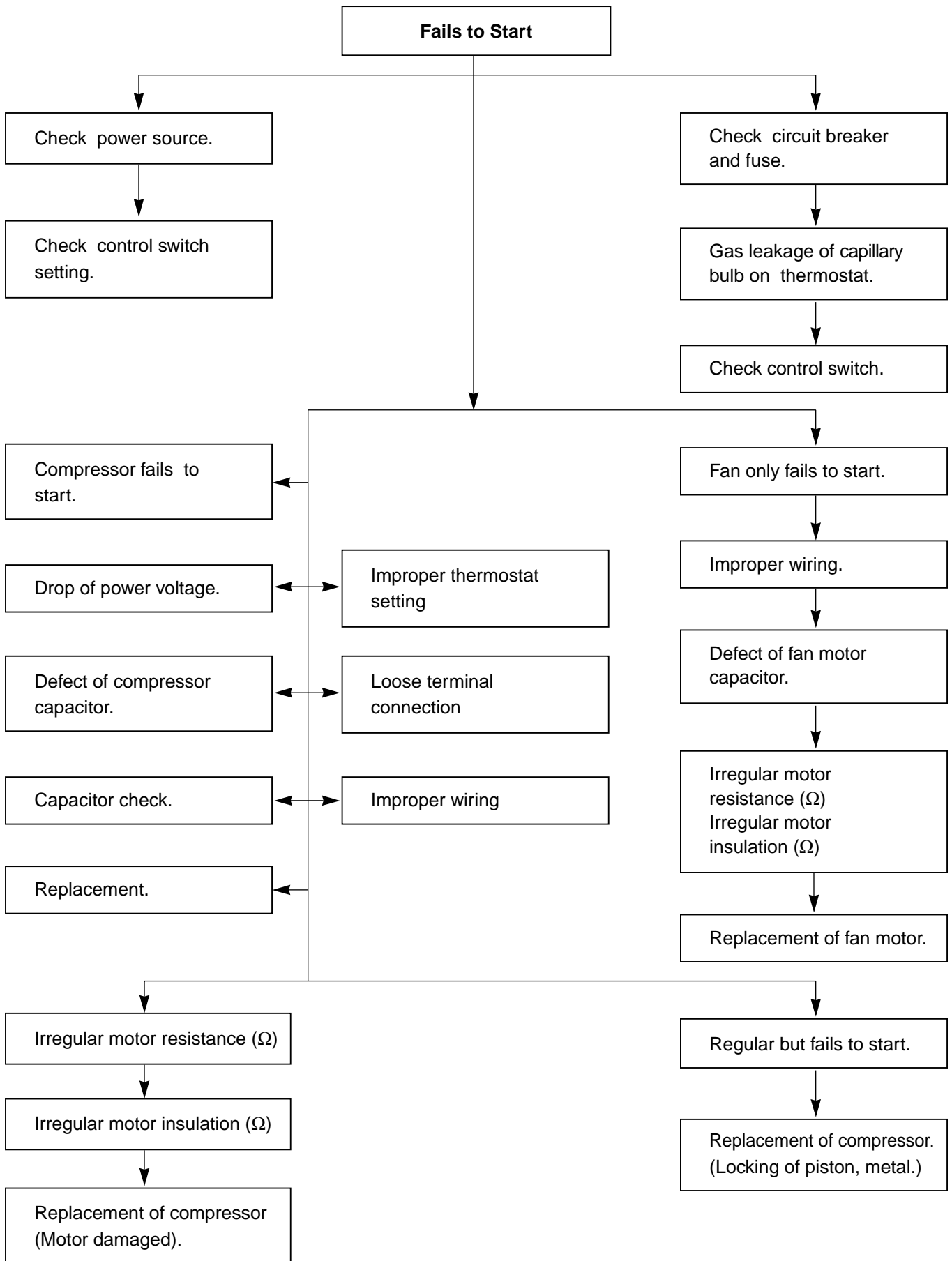

## ROOM AIR CONDITIONER VOLTAGE LIMITS

NAME PLATE RATING	MINIMUM	MAXIMUM
115V ± 10%	103.5V	126.5V

COMPLAINT	CAUSE	REMEDY
Fan motor will not run.	No power	Check voltage at outlet. Correct if none.
	Power supply cord	Check voltage to rotary switch. If none, check power supply cord. Replace cord if circuit is open.
	Rotary switch	Check switch continuity. Refer to wiring diagram for terminal identification. Replace switch if defective.
	Wire disconnected or connection loose	Connect wire. Refer to wiring diagram for terminal identification. Repair or replace loose terminal.
	Capacitor (Discharge capacitor before testing.)	Test capacitor. Replace if not within ±10% of manufacturer's rating. Replace if shorted, open, or damaged.
	Will not rotate	Fan blade hitting shroud or blower wheel hitting scroll. Re-align assembly.  Units using slinger ring condenser fans must have 0.22~0.25 inch clearance to the base. If necessary, shim up the bottom of the fan motor with mounting screw(s).  Check fan motor bearings; if motor shaft will not rotate, replace the motor.
Fan motor runs.	Revolves on overload	Check voltage. See limits on this page.  If not within limits, call an electrician.  Test capacitor. Check bearings. Does the fan blade rotate freely? If not, replace fan motor.  Pay attention to any change from high speed to low speed. If the speed does not change, replace the motor.



COMPLAINT	CAUSE	REMEDY
Fan motor noise.	Fan	If cracked, out of balance, or partially missing, replace it.
	Blower	If cracked, out of balance, or partially missing, replace it.
	Loose set screw	Tighten it.
	Worn bearings	If knocking sounds continue when running or loose, replace the motor. If the motor hums or noise appears to be internal while running, replace motor.
Compressor will not run, fan motor runs.	Voltage	Check voltage. See the limits on the preceding page. If not within limits, call an electrician.
	Wiring	Check the wire connections; if loose, repair or replace the terminal. If the wires are disconnected, refer to wiring diagram for identification, and replace the wires. Check the wire connections; If not according to the wiring diagram, correct the connections.
	Rotary Switch	Check for continuity, refer to the for terminal identification. Replace the switch if the circuit is open.
	Thermostat	Check the position of knob. If not at the coldest setting, advance the knob to this setting and restart the unit.
		Check the continuity of the thermostat. Replace the thermostat if the circuit is open.
	Capacitor (discharge capacitor before servicing.)	Check the capacitor. Replace if not within $\pm 10\%$ of manufacturer's rating, replace if shorted, open, or damaged.
	Compressor	Check the compressor for open circuit or ground. If open or grounded, replace the compressor.
Overload	Check the compressor overload if externally mounted. Replace if open. (If the compressor temperature is high, remove the overload, cool, and retest.)	
Compressor cycles on overload.	Voltage	Check the voltage. See the limits on the preceding page. If voltage is not within these limits, call an electrician.
	Overload	Check overload, if externally mounted. Replace if open. (If the compressor temperature is high, remove the overload, cool, and retest.)

<b>COMPLAINT</b>	<b>CAUSE</b>	<b>REMEDY</b>
Compressor cycles on overload.	Fan motor	If not running, determine the cause. Replace if required.
	Condenser air flow restriction	Remove the cabinet, inspect the interior surface of the condenser. If restricted, clean carefully with a vacuum cleaner (do not damage fins) or brush. Clean the interior base before re-assembling.
	Condenser fins (damaged)	If the condenser fins are closed over a large area on the coil surface, head pressures will increase, causing the compressor to cycle. Straighten the fins or replace the coil.
	Capacitor	Test the capacitor.
	Wiring	Check the terminals. If loose, repair or replace.
	Refrigeration system	Check the system for a restriction.
Insufficient cooling	Air filter	If restricted, clean or replace.
	Unit undersized	Determine if the unit is properly sized for the area to be cooled.
Excessive noise	Blower or fan	Check the set screw, or clamp. If loose or missing, correct. If the blower or fan is hitting scroll or barrier, rearrange the air handling parts.
	Copper tubing	Remove the cabinet and carefully rearrange the tubing not to contact the cabinet, compressor, shroud, and barrier.

# 4. CIRCUIT DIAGRAM

MODEL: ZQ05B10,ZQ07B10

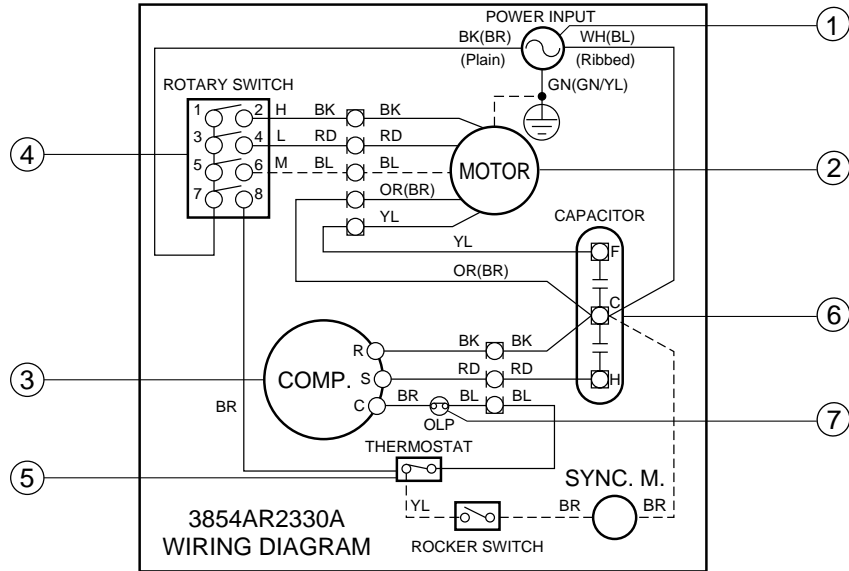

S: Service Parts  
N: Non Service Parts

LOCATION NO.	DESCRIPTION	Q'TY PER SET	RE-MARKS
1	POWER CORD ASSY	1	S
2	FAN MOTOR	1	S
3	COMPRESSOR	1	S
4	ROTARY SWITCH	1	S
5	THERMOSTAT	1	S
6	CAPACITOR	1	S
7	OVERLOAD PROTECTOR	1	S

# 5. EXPLODED VIEW

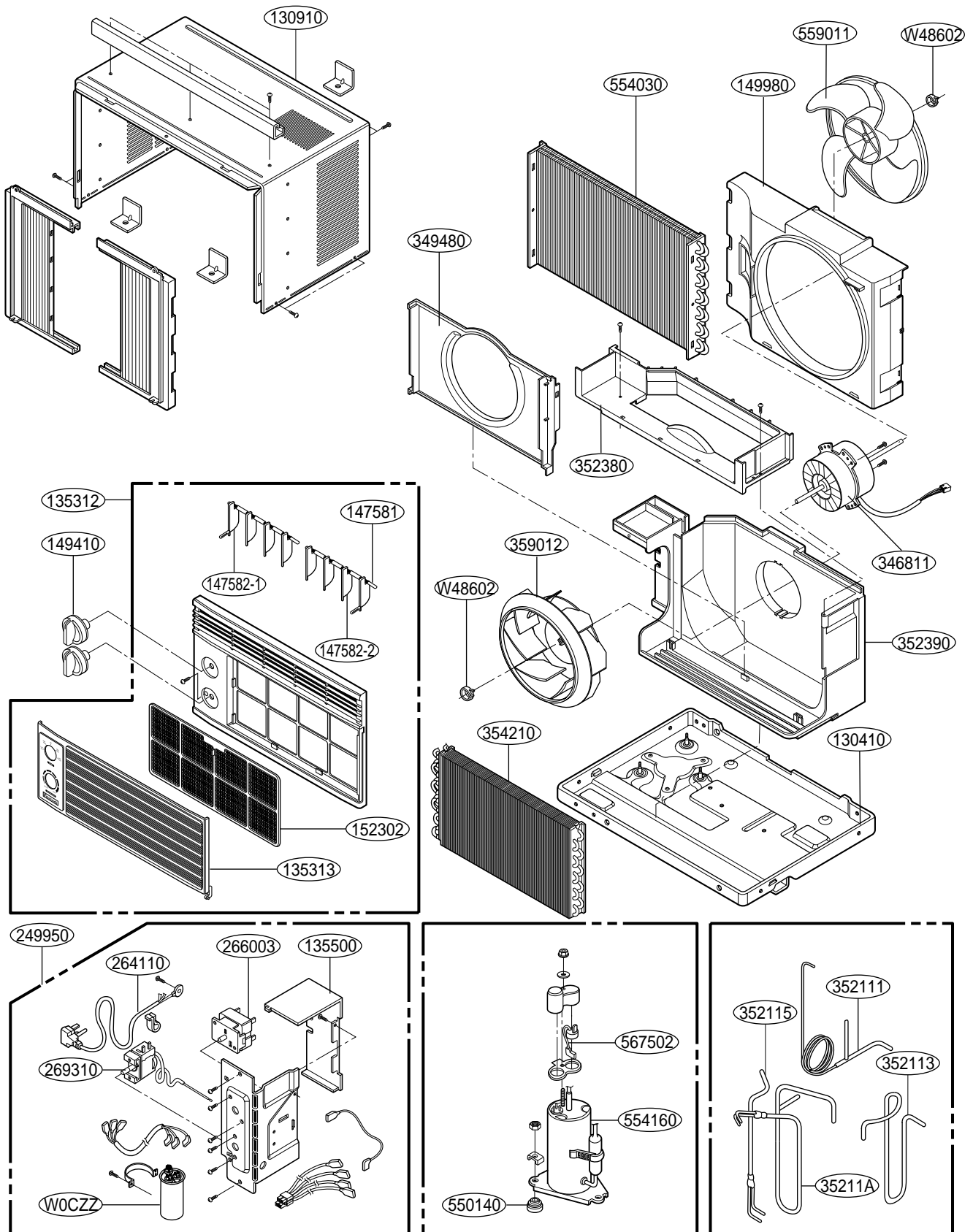

## 6. SERVICE PARTS LIST

• ZQ05B10 . ZQ07B10

<b>ZQ05B10</b>		
<b>Loc No</b>	<b>FRIEDRICH</b>	<b>Description</b>
130410	67302921	BASE ASSEMBLY,WELD[SINGLE]
130910	67303709	CABINET ASSEMBLY,SINGLE
135312	67306003	GRILLE ASSEMBLY,FRONT(SINGLE)
135313	67306103	GRILLE,INLET
135500	67300309	COVER
147581	67304600	LINK
147582-1	67304500	VANE,VERTICAL
147582-2	67304501	VANE,VERTICAL
149410	67304100	KNOB ASSEMBLY
149980	67303100	SHROUD
152302	67304300	FILTER(MECH),A/C
264110	67300017	POWER CORD ASSEMBLY
266003	67300500	SWITCH,ROTARY
269310	67300400	THERMOSTAT ASSEMBLY
346811	67303027	MOTOR ASSEMBLY,SINGLE
349480	67303410	ORIFICE
352111	67302119	TUBE ASSEMBLY,CAPILLARY
352115	67302004	TUBE ASSEMBLY,EVAPORATOR IN
352380	67302728	AIR GUIDE
352390	67302727	AIR GUIDE ASSEMBLY
354210	67302423	EVAPORATOR ASSEMBLY,FIRST
359012	67302612	FAN,TURBO
550140	67301900	ISOLATOR,COMP
554030	67303321	CONDENSER ASSEMBLY
554160	67301616	COMPRESSOR SET
559011	67302613	FAN ASSEMBLY,AXIAL
567502	67301405	O.L.P
W0CZZ	67300718	CAPACITOR,DRAWING
W48602	67302500	CLAMP,SPRING

## ZQ07B10

<b>Loc No</b>	<b>FRIEDRICH</b>	<b>Description</b>
130410	67302921	BASE ASSEMBLY,WELD[SINGLE]
130910	67303709	CABINET ASSEMBLY,SINGLE
135312	67306003	GRILLE ASSEMBLY,FRONT(SINGLE)
135313	67306103	GRILLE,INLET
135500	67300309	COVER
147581	67304600	LINK
147582-1	67304500	VANE,VERTICAL
147582-2	67304501	VANE,VERTICAL
149980	67303100	SHROUD
152302	67304300	FILTER(MECH),A/C
264110	67300017	POWER CORD ASSEMBLY
266003	67300500	SWITCH,ROTARY
269310	67300400	THERMOSTAT ASSEMBLY
346811	67303026	MOTOR ASSEMBLY,SINGLE
352380	67302726	AIR GUIDE
352390	67302727	AIR GUIDE ASSEMBLY
354210	67302422	EVAPORATOR ASSEMBLY,FIRST
359012	67302612	FAN,TURBO
550140	67301900	ISOLATOR,COMP
552111	67302118	TUBE ASSEMBLY,CAPILLARY
554030	67303320	CONDENSER ASSEMBLY,FIRST
554160	67500117	COMPRESSOR SET,CHINA
559011	67302613	FAN ASSEMBLY,AXIAL
567502	67301415	O.L.P
W0CZZ	67300719	CAPACITOR,DRAWING
W48602	67302500	CLAMP,SPRING

# MEMO

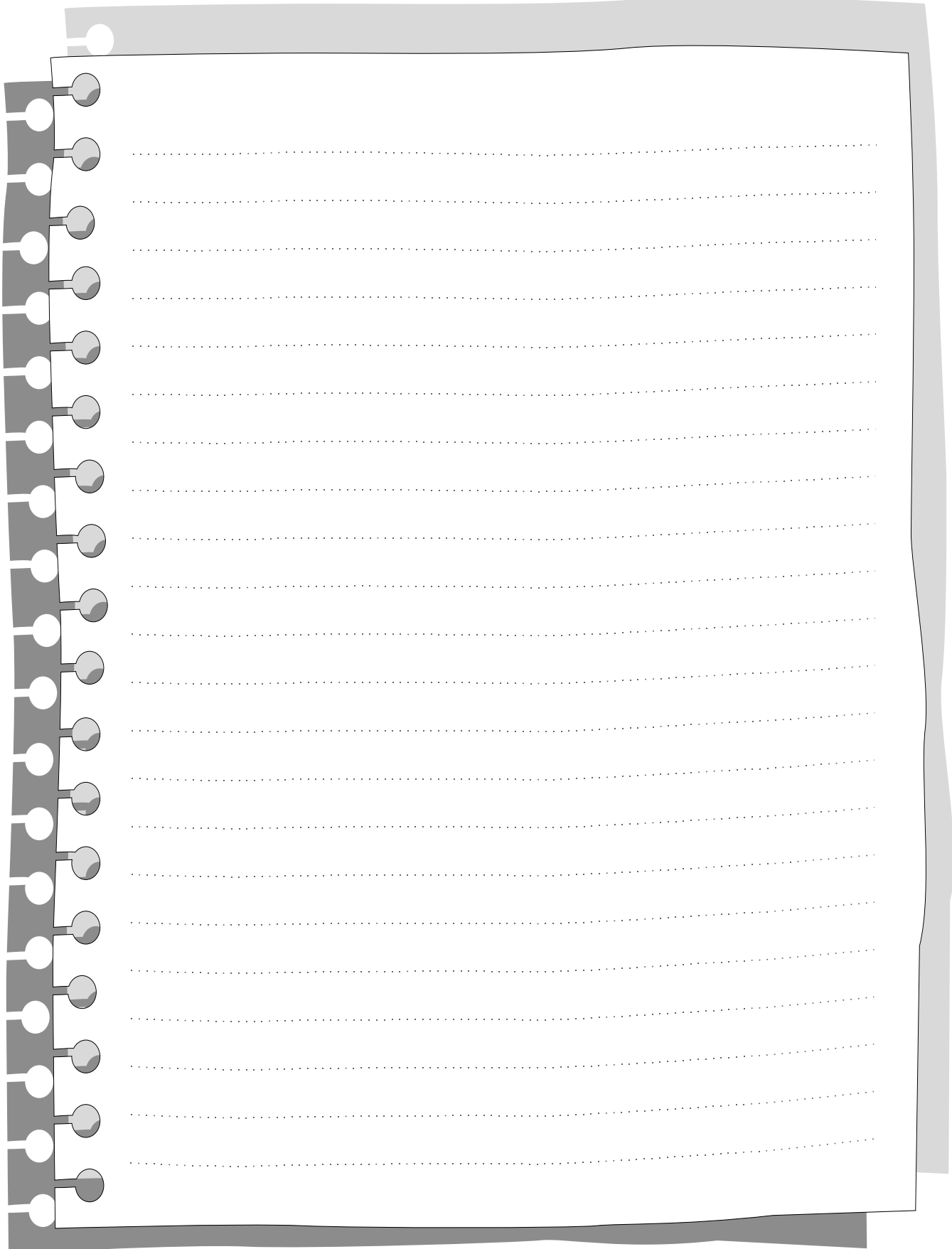

**Use Factory Certified Parts...**

***Friedrich***<sup>®</sup>

FRIEDRICH AIR CONDITIONING CO.

Visit our web site at [www.friedrich.com](http://www.friedrich.com)

Post Office Box 1540 • 4200 N. Pan Am Expressway • San Antonio, Texas 78295-1540  
• (210) 357-4400 • FAX (210) 357-4490

