

# SERVICE MANUAL

## 17" LCD Monitor

DELL E173FP



THESE DOCUMENTS ARE FOR REPAIR SERVICE INFORMATION ONLY. EVERY REASONABLE EFFORT HAS BEEN MADE TO ENSURE THE ACCURACY OF THIS MANUAL; WE CANNOT GUARANTEE THE ACCURACY OF THIS INFORMATION AFTER THE DATE OF PUBLICATION AND DISCLAIMS RE LIABILITY FOR CHANGES, ERRORS OR OMISSIONS.

**Prepared By: WuHaiyan**  
**Checked By: Sushi**  
**Manufacture Date: May-29-04**

## Table of Contents

Table of Contents	-----	2
1. MONITOR SPECIFICATIONS	-----	4
2. LCD MONITOR DESCRIPTION	-----	5
3. OPERATING INSTRUCTIONS	-----	6
3.1 GENERAL INSTRUCTIONS	-----	6
3.2 CONTROL BUTTONS	-----	6
3.3 ADJUSTING THE PICTURE	-----	7
4. Input/Output Specification	-----	10
4.1 Input Signal Connector	-----	10
4.1.1 Analog D-SUB Connector	-----	10
4.2 Factory Preset Display Modes	-----	10
4.3 Power Supply Requirements	-----	11
4.3.1 Input Requirements	-----	11
4.3.2 Output Requirements	-----	11
4.4 PANEL SPECIFICATION	-----	11
4.4.1 Panel Feature	-----	11
4.4.2 Display Characteristics	-----	11
4.4.3 Optical Characteristics	-----	12
4.4.4 Parameter guide line for CCFL Inverter	-----	12
5. Block Diagram	-----	13
5.1 Monitor Exploded View	-----	13
5.2 Software Flow Chart	-----	14
5.3 Electrical Block Diagram	-----	16
5.3.1 Main Board	-----	16
5.3.2 Inverter/Power Board	-----	17
6. Schematic	-----	18
6.1 Main Board	-----	18
6.2 Inverter/Power Board	-----	23

7. PCB Layout	25
7.1 Main Board	25
7.2 Inverter/Power Board	26
7.3 Keypad Board	28
8. Maintainability	29
8.1 Equipments and Tools Requirements	29
8.2 Trouble Shooting	30
8.2.1 Main Board	30
8.2.2 Power/Inverter Board	33
8.2.3 Key Pad Board	35
9. White-Balance, Luminance adjustment	36
10. EDIT Content	38
11. ISP User Manual	39
11.1. Connect ISP Writer preparation action	39
11.2. To Use ISP WRITER	39
11.3. Executing ISP	43
12. BOM List	44

## 1. MONITOR SPECIFICATIONS

LCD Panel	Driving system	TFT Color LCD
	Size	43cm(17.0")
	Pixel pitch	0.264mm(H) x 0.264mm(V)
	Viewable angle	140° (H) 120° (V)
	Response time (typ.)	16 ms
Input	Video	Analog Only
	Sync. Type	H/V TTL Separate and Composite Sync.
	H-Frequency	30kHz – 80kHz
	V-Frequency	56-75Hz
Display Colors		Over 16.2 million Colors
Dot Clock		135MHz
Max. Resolution		1280 x 1024
Plug & Play		VESA DDC2B™
Power Consumption	ON Mode	<35W
	Power Saving	≤2W
Maximum Screen Size		Horizontal : 337.92mm Vertical: 270.336mm
Power Source		90~264VAC,47~63Hz
Environmental Considerations		Operating Temp: 0°C to 50°C Storage Temp.: -20°C to 60°C Operating Humidity: 10% to 90%
Weight (N. W.)	Packaged	5.8Kgs Unit
	Unpackaged	4.6Kgs Unit

## 2. LCD MONITOR DESCRIPTION

The LCD MONITOR will contain a main board, an internal inverter/power board, keypad board, which house the flat panel control logic, brightness control logic and DDC.

The internal Inverter/power board will drive the backlight of panel and the DC-DC conversion. and provides the 12V DC-power to main board.

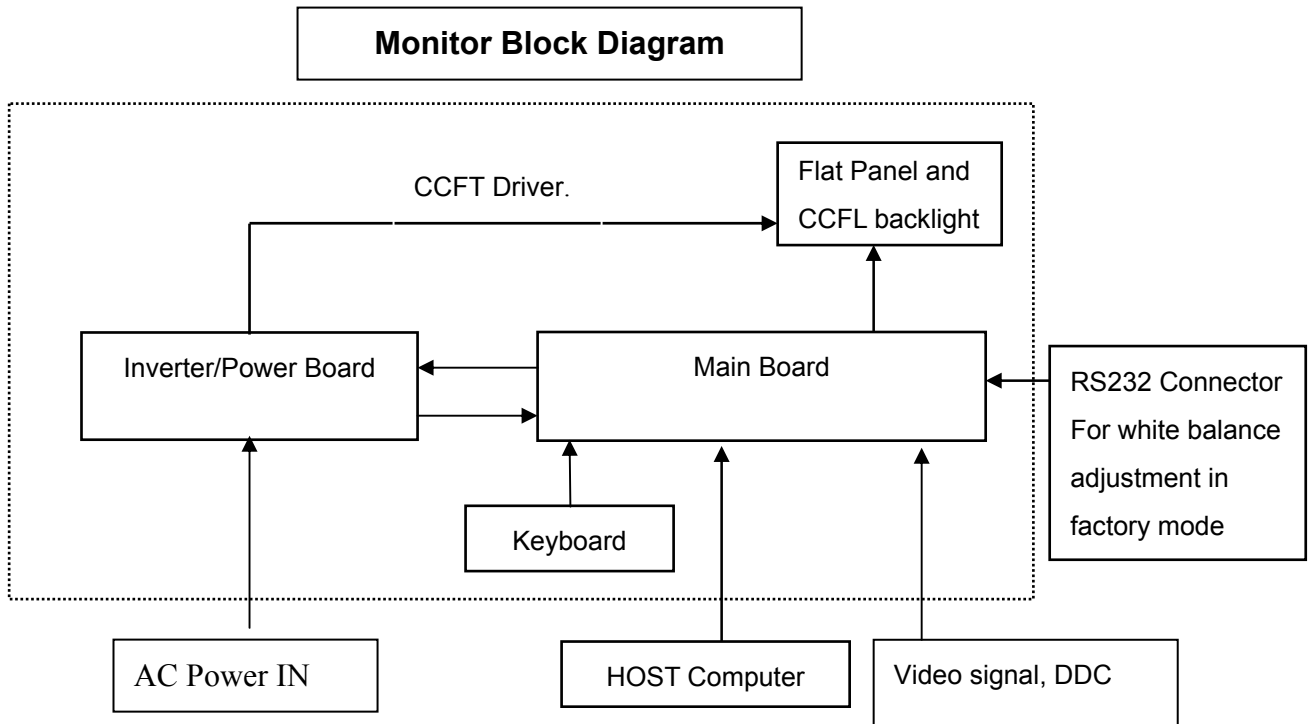

### 3. OPERATING INSTRUCTIONS

#### 3.1 GENERAL INSTRUCTIONS

Press the power button to turn the monitor on or off. The other control buttons are located at front panel of the monitor. By changing these settings, the picture can be adjusted to your personal preferences.

- The power cord should be connected.
- Connect the video cable from the monitor to the video card.
- Press the power button to turn on the monitor, the power indicator will light up.

#### 3.2 CONTROL BUTTONS

- **Power Button:**

When pressed, the monitor enters the off mode, and the LED turns blank. Press again to restore normal status.

- **Brightness Button:**

The Brightness Button is used to select the Brightness/Contrast adjust functions. Press to switch functions or adjust settings.

- **Auto Adjust Key:**

The Auto Adjust Key is used to automatically set the H Position, V Position, Clock and Phase.

- **Power Indicator:**

Green — Power On mode.  
 Orange — Power Saving mode.  
 Blank — Power Off Mode.

#### Control Buttons

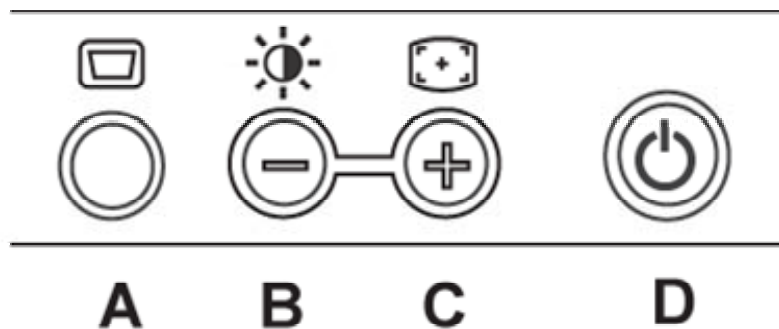

- A. Buttons for the OSD menu  
 (On-Screen-display)  
 B. Brightness Button  
 C. Auto Adjust Button  
 D. Power On/Off Button and indicator

### 3.3 ADJUSTING THE PICTURE

To set the OSD menu, perform the following steps:  
Briefly press the SELCT / MENU button to activate the OSD menu.

**The main menu appears on the screen with icons for the setting functions.**

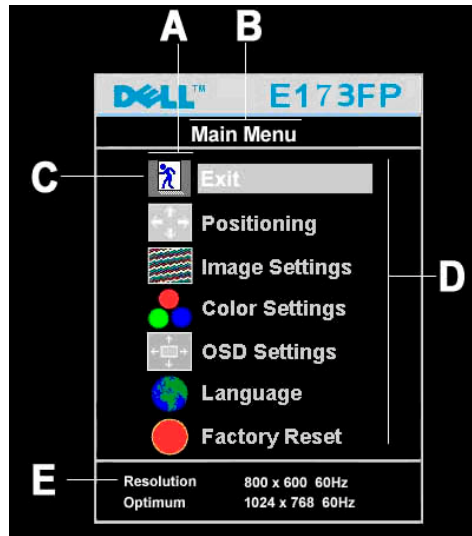

The first symbol (*Exit*) is highlighted.

Necessary, press the - or + button to mark another icon (e.g. *Positioning*).

Press the SELECT/MENU button to select the highlighted icon.

**The corresponding setting window (here: *Positioning*) is displayed.**

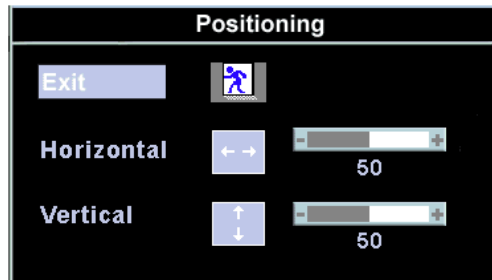

The first symbol (*Exit*) is highlighted.

If necessary, press the – or + button to mark the desired icon.

Press the SELECT/MENU button to select the highlighted function.

Press the – or + button to adjust the value for the selected function.

Press the SELECT/MENU button to exit the function.

Press the SELECT/MENU button to exit the sub-menu when “Exit” function is highlighted;

**All changes are stored automatically.**

#### Adjusting the brightness and contrast

	Calling the <i>Brightness / Contrast</i> setting window using Brightness button.
Brightness	Setting the brightness of the display With this function you change the brightness of the background lighting.
Contrast	Setting the contrast of the display With this function you modify the contrast of bright colour tones.

## Adjusting size and position

	Calling the Positioning setting window
H-Position	Adjusting the horizontal position With this function you move the picture to the left or to the right.
V-Position	Adjusting the vertical position With this function you move the picture up or down.

## Setting Image

	Calling the Image setting window
Auto Adjust	Auto adjust will produce best image automatically, The information of " Auto Adjust In Progress" will show;
Pixel clock	Adjusting the pixel clock
Phase	Adjusting the phase

## Setting colour temperature and colours

	Calling the <i>Color</i> setting window
	<p>Selecting the colour temperature</p> <p>The colour temperature is measured in K (= Kelvin). You can select from Normal Preset, Blue Preset, Red Preset to User Preset;</p> <p><i>Normal preset</i> = Original colour of the LCD display, it's 6500K;</p> <p><i>Blue preset</i> = 5700K colour of the LCD display, it's 9300K;</p> <p><i>Red preset</i> = 9300K colour of the LCD display, it's 5700K;</p> <p><i>User preset</i> = Setting user-defined colours</p> <p>In the user preset setting you can change the colour ratios of the basic colours (red, green, blue) as required.</p>

## Setting display of the OSD menu

	Calling the <i>OSD Set up</i> setting window
Horizontal Position	Setting the horizontal position of the OSD menu With this function you move the OSD menu to the left or to the right.
Vertical Position	Setting the vertical position of the OSD menu With this function you move the OSD menu up or down.



OSD Hold Time	<p>Setting the display duration of the OSD menu</p> <p>With this function you select a value from 0 to 60 seconds.</p> <p>If the set time expires without a setting being made, the OSD menu is automatically faded out.</p>
OSD Lock	<p>Setting the display of the OSD menu lock or unlock.</p> <p>With this function you select Yes to lock OSD, NO to unlock it.</p>

### Setting Language

	<p>Calling the <i>Language</i> setting window</p>
	<p>With this function you choose between English (default setting), French, German, Spanish and Japanese as the language for the OSD menu.</p>

### Factory Reset

	<p>Activating the factory settings</p>
	<p>With this function all settings except Language of OSD are reset to the factory settings without prompting for confirmation.</p>

## 4. Input/Output Specification

### 4.1 Input Signal Connector

#### 4.1.1 Analog D-SUB Connector

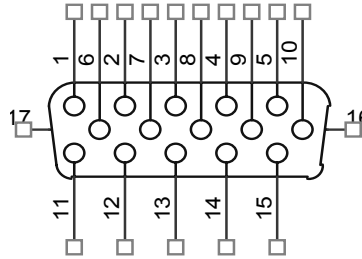

Pin	Meaning	Pin	Meaning
1	Video input red	9	+5 V (DDC)
2	Video input green	10	VGA-PG
3	Video input blue	11	Ground
4	Ground	12	DDC-Data
5	Ground	13	H. Sync
6	Red video ground	14	V. Sync
7	Green video ground	15	DDC Clock
8	Blue video ground		

### 4.2 Factory Preset Display Modes

The following are the most frequently used of the preset operating modes:

Horizontal frequency	Refresh rate	Screen resolution
31.5 kHz	70 Hz	720 x 400
31.5 kHz	60 Hz	640 x 480
37.5 kHz	75 Hz	640 x 480
37.9 kHz	60 Hz	800 x 600
46.9 kHz	75 Hz	800 x 600
48.4 kHz	60 Hz	1024 x 768
60.0 kHz	75 Hz	1024 x 768
67.5KHz	75Hz	1152 x 864
64.0KHz	60Hz	1280 x 1024
79.9KHz	75Hz	1280 x 1024

For ergonomic reasons, a screen resolution of **1280 x 1024** pixels is recommended. Because of the technology used (active matrix) an LCD monitor provides a totally flicker-free picture even with a refresh rate of 60 Hz.

### 4.3 Power Supply Requirements

#### 4.3.1 Input Requirements

AC INPUT VOLTAGE: 90V ~ 264V

AC INPUT FREQUENCY: 47 ~ 63 HZ

AC INPUT CURRENT: 1.5A max.

INRUSH CURRENT: 60A MAX AT 264VAC COLD START

LEAKAGE CURRENT: 3.5 mA MAX and less then 0.25 mA at 100Vac

#### 4.3.2 Output Requirements

ITEM	MIN.	TYP.	MAX.	UNIT	REMARK
Output voltage (12V)	11.4	12	12.6	V	
Output current (12V)	0	2.0	3.0	A	
Output voltage ( 5V)	4.75	5.0	5.25	V	
Output current (5V)	0	1.5	2.0	A	
Ripple & Noise (12V)			200	mV	
Ripple & Noise (5V)			100	mV	

### 4.4 PANEL SPECIFICATION

#### 4.4.1 Panel Feature

- High contrast ratio, high aperture structure
- Wide viewing angle
- High-speed response
- SXGA (1280 x 1024 pixels) resolution
- Low power consumption

#### 4.4.2 Display Characteristics

Items	Specification	Unit
Display Area	337.92x270.336	mm
Driver element	a-Si TFT active matrix	
Display color	16.2M	Colors
Number of pixels	1280 x 1024	pixel
Pixel Arrangement	RGB vertical stripe	
Pixel pitch	0.264(H) x 0.264(W)	mm
Display Mode	Normally Black	

### 4.4.3 Optical Characteristics

The optical characteristics are measured under stable conditions at 25°C (Room Temperature):

Parameter	Symbol	Values			Units	Notes
		Min.	Typ.	Max.		
Contrast ratio	CR	300	500	-		1
Surface luminance, white	$L_{WH}$	200	250	-	cd/m <sup>2</sup>	2
Luminance uniformity	$\Delta L_g$	75	-	-	%	3
Response time	$T_r$		16	30	ms	4
Rise time	$T_{rR}$	-	4	6		
Decay time	$T_{rD}$	-	12	24		
CIE color coordinates						
Red	XR	0.611	0.641	0.671		
	YR	0.312	0.342	0.372		
Green	XG	0.262	0.292	0.322		
	YG	0.581	0.611	0.641		
Blue	XB	0.117	0.147	0.177		
	YB	0.038	0.068	0.098		
White	XW	0.283	0.313	0.343		
	YW	0.299	0.329	0.359		
Viewing angle (by CR $\geq 10$ )						5
X axis, right( $\phi=0^\circ$ )	$\theta_r$	60	70	-	degree	
X axis, left ( $\phi=180^\circ$ )	$\theta_l$	60	70	-		
Y axis, up ( $\phi=90^\circ$ )	$\theta_u$	45	60	-		
Y axis, down ( $\phi=270^\circ$ )	$\theta_d$	50	60	-		
Viewing angle (by CR $\geq 5$ )						degree
X axis, right( $\phi=0^\circ$ )	$\theta_r$	70	80	-		
X axis, left ( $\phi=180^\circ$ )	$\theta_l$	70	80	-		
Y axis, up ( $\phi=90^\circ$ )	$\theta_u$	55	65	-		
Y axis, down ( $\phi=270^\circ$ )	$\theta_d$	65	75	-		
Relative brightness		-	-	-		6 Figure 10 Figure 13
Luminance uniformity (TCO99)				1.7		
Crosstalk				1.8	%	

### 4.4.4 Parameter guide line for CCFL Inverter

Parameter	Symbol	Values			Units	Notes
		Min.	Typ.	Max.		
MODULE :						
Power Supply Input Voltage	$V_{CC}$	4.5	5.0	5.5	V	
Permissive Power Input Ripple	$V_{RF}$	-	-	0.1	V	
Power Supply Input Current	$I_{CC}$	-	0.45	0.52	A	1
Differential Impedance	$Z_m$	90	100	110	ohm	
Power Consumption	$P_c$	-	2.25	2.60	Watts	
Rush Current	$I_{RUSH}$	-	2.0	3.0	A	2
LAMP for each CCFL:						
Operating Voltage	$V_{BL}$	640 (@7.0mA)	650 (@6.5mA)	745 (@2.5mA)	$V_{RMS}$	3
Operating Current	$I_{BL}$	2.5	6.5	7.0	$mA_{RMS}$	4
Established Starting Voltage at 25 °C	$V_{BS}$	-	-	1000	$V_{RMS}$	
at 0 °C		-	-	1250	$V_{RMS}$	
Operating Frequency	$f_{BL}$	40	60	70	KHZ	5
Discharge Stabilization Time	$T_s$	-	-	3	Minutes	6
Power Consumption	$P_{BL}$	-	16.90	18.60	Watts	7
Life Time		50,000	-	-	Hrs	8

## 5. Block Diagram

### 5.1 Monitor Exploded View

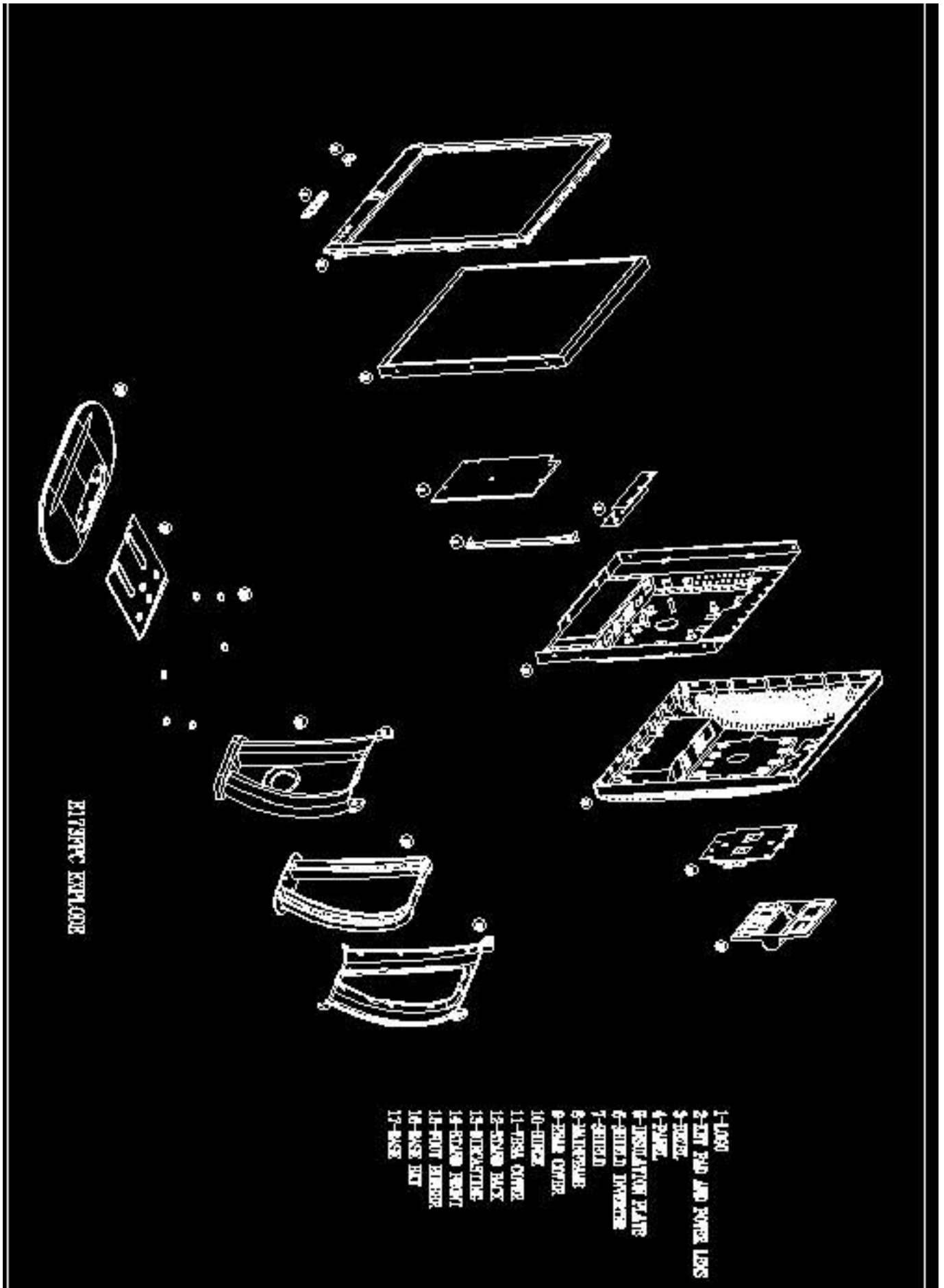

5.2 Software Flow Chart

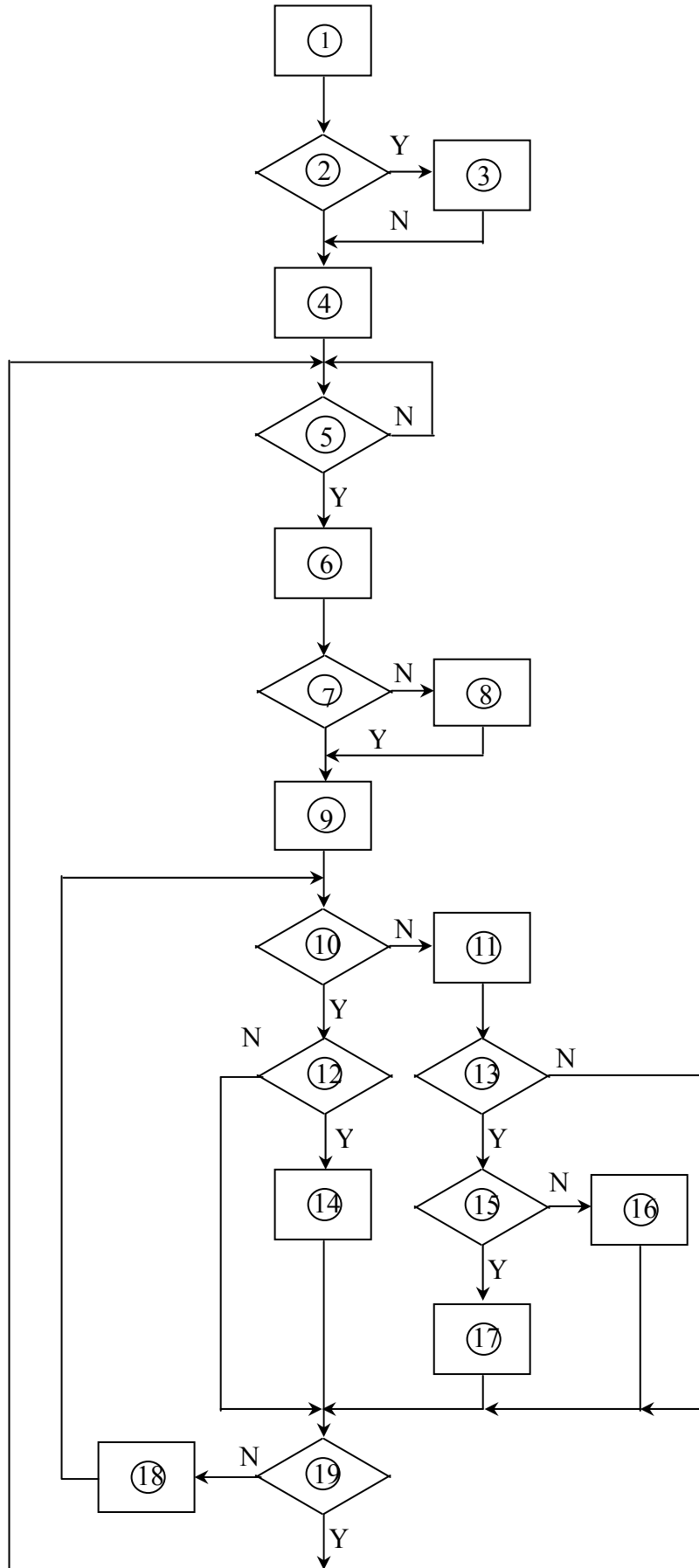

- 1) MCU Initializes.
- 2) Is the EEprom blank?
- 3) Program the EEprom by default values.
- 4) Get the PWM value of brightness from EEprom.
- 5) Is the power key pressed?
- 6) Clear all global flags.
- 7) Are the AUTO and SELECT keys pressed?
- 8) Enter factory mode.
- 9) Save the power key status into EEprom.  
Turn on the LED and set it to green color.  
Scalar initializes.
- 10) In standby mode?
- 11) Update the lifetime of back light.
- 12) Check the analog port, are there any signals coming?
- 13) Does the scalar send out an interrupt request?
- 14) Wake up the scalar.
- 15) Are there any signals coming from analog port?
- 16) Display "No connection Check Signal Cable" message. And go into standby mode after the message disappears.
- 17) Program the scalar to be able to show the coming mode.
- 18) Process the OSD display.
- 19) Read the keyboard. Is the power key pressed?

### 5.3 Electrical Block Diagram

#### 5.3.1 Main Board

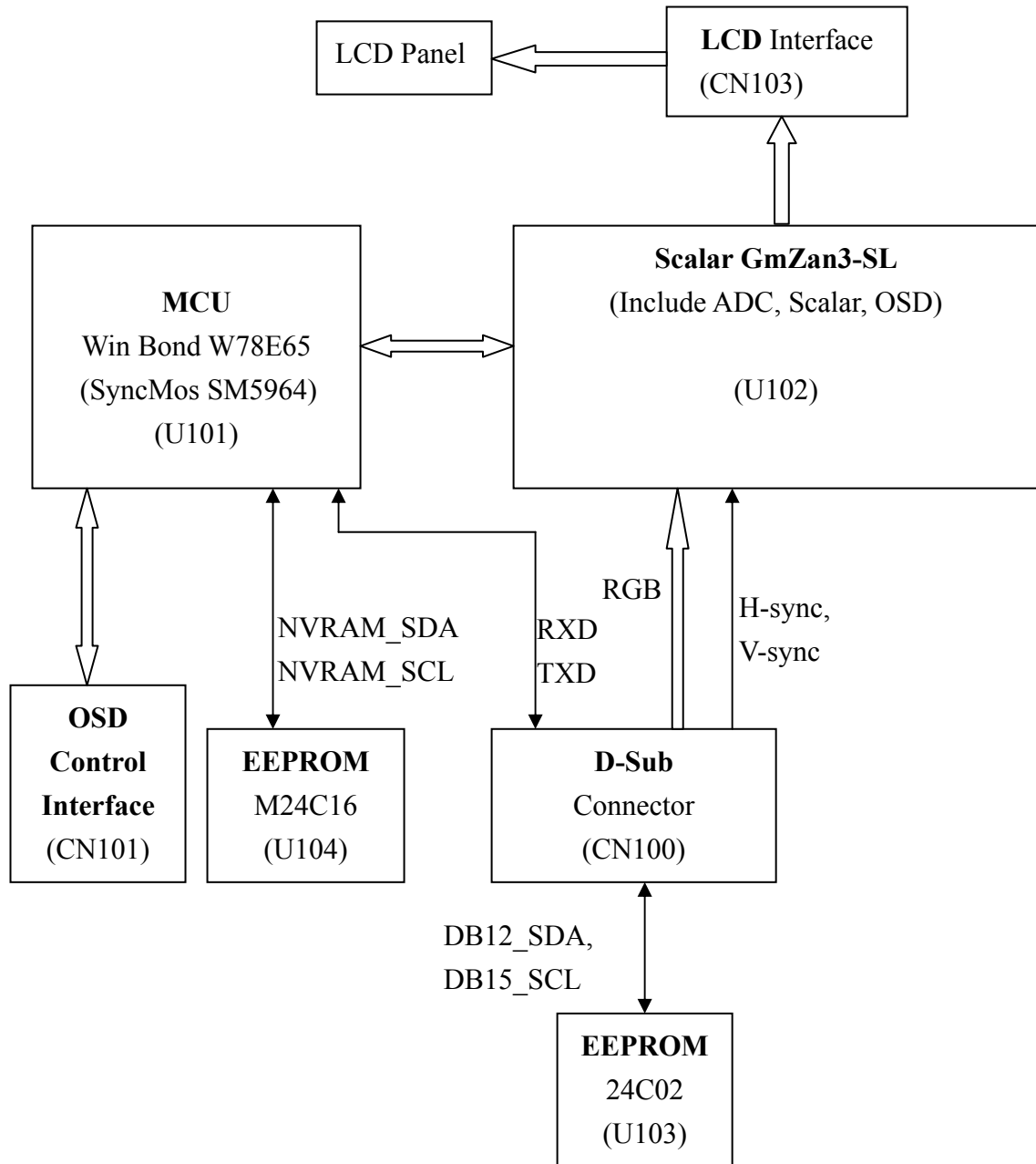



5.3.2 Power Block Diagram

**PWPC1742LGD1**  
**Function test**

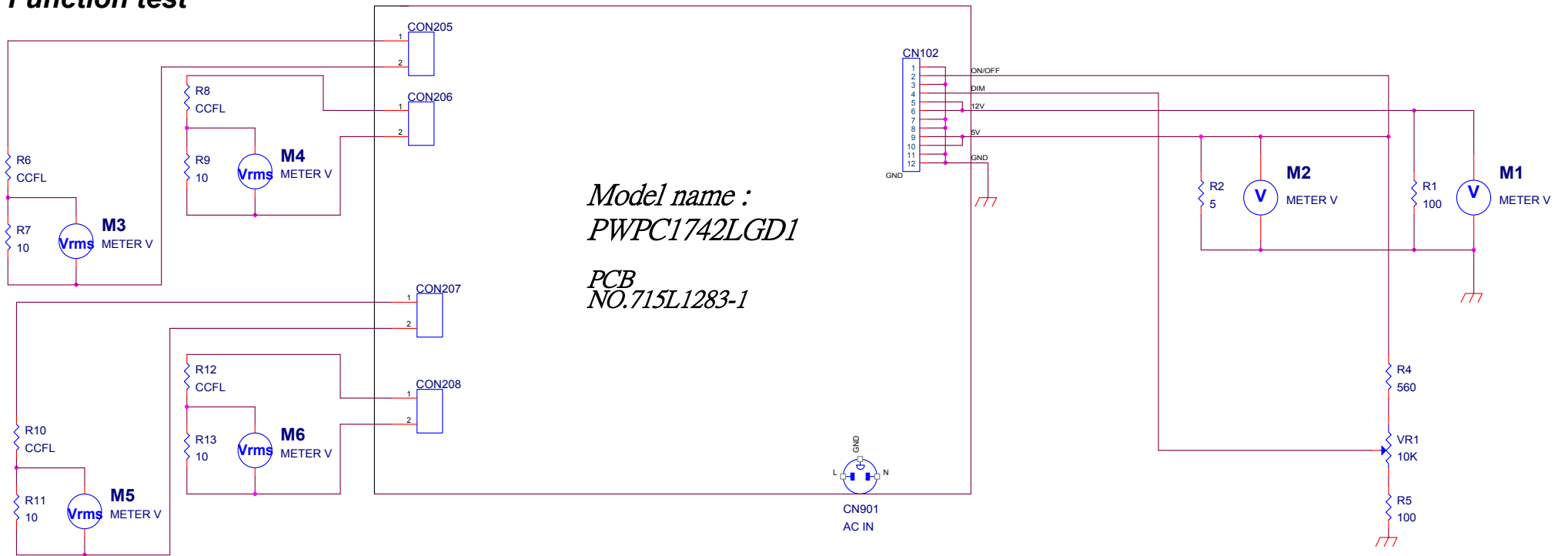

**Function test step :**

**Step1 :**

1. Adjust VR1 ( Set Vdim voltage from 0V to 5V ), then check M3 / M4/M5/M6 Vrms .

2. Check M3 / M4/M5/M6operating frequency. ( note 1 )

Note 1: M3 / M4/M5/M6 need to use two channel multimeter , such as FLUKE 45 , or use the oscilloscope check frequency.

**Specification :**

M1 = 12V +- 0.5V , M2 = 5V +- 0.25V

1. M3 / M4/M5/M6 = 6.5 +- 5 mV @ DIM= 5V

M3 / M4 /M5/M6= 3.0 +- 5 mV @ DIM= 0V

2. M3 / M4/M5/M6= 55KHz +- 5 KHz

6. Schematic  
6.1 Main Board

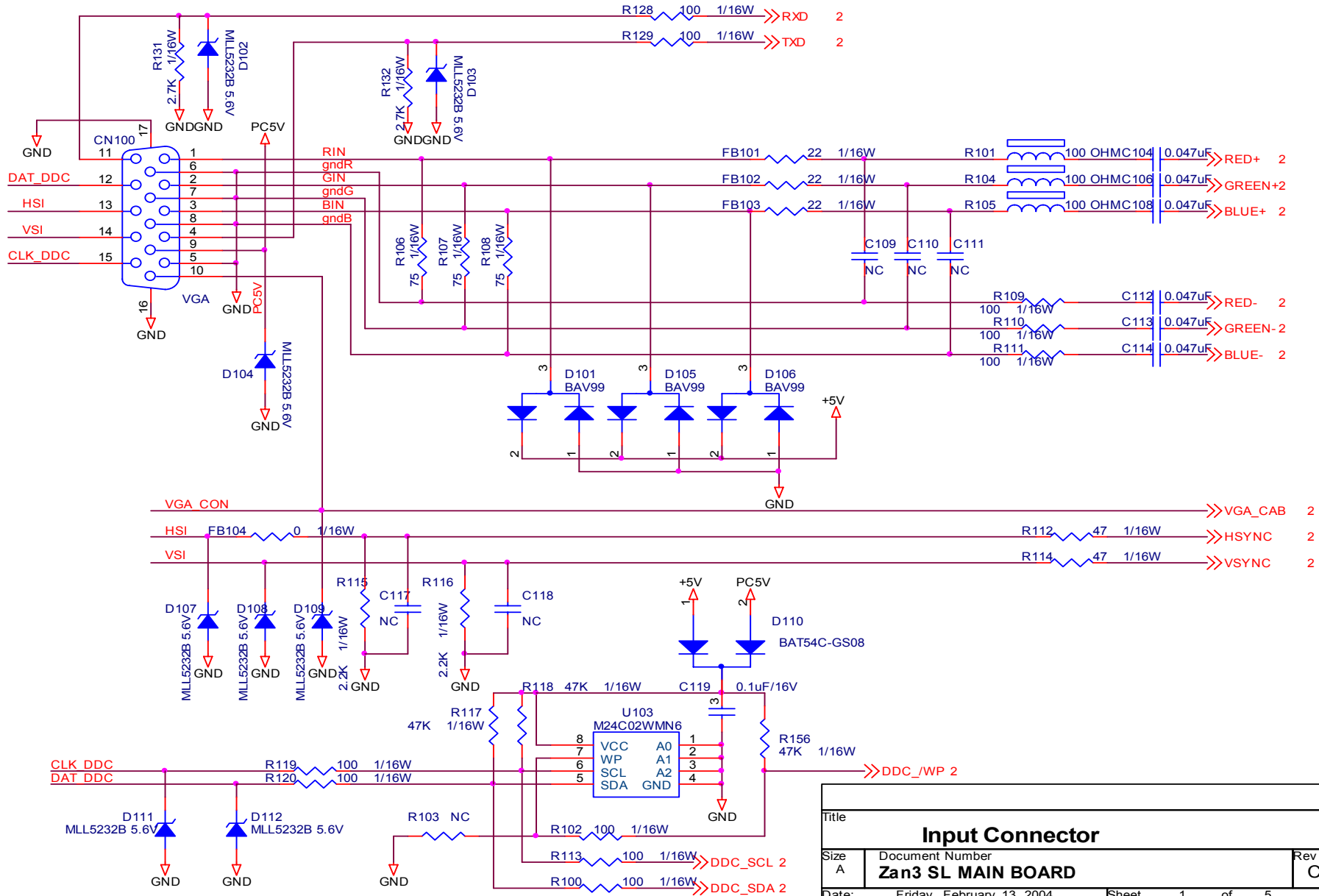

Title		
<b>Input Connector</b>		
Size	Document Number	Rev
A	<b>Zan3 SL MAIN BOARD</b>	C
Date:	Friday, February 13, 2004	Sheet 1 of 5

# DELL E173FP Service Manual

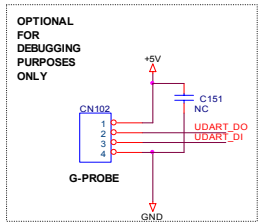
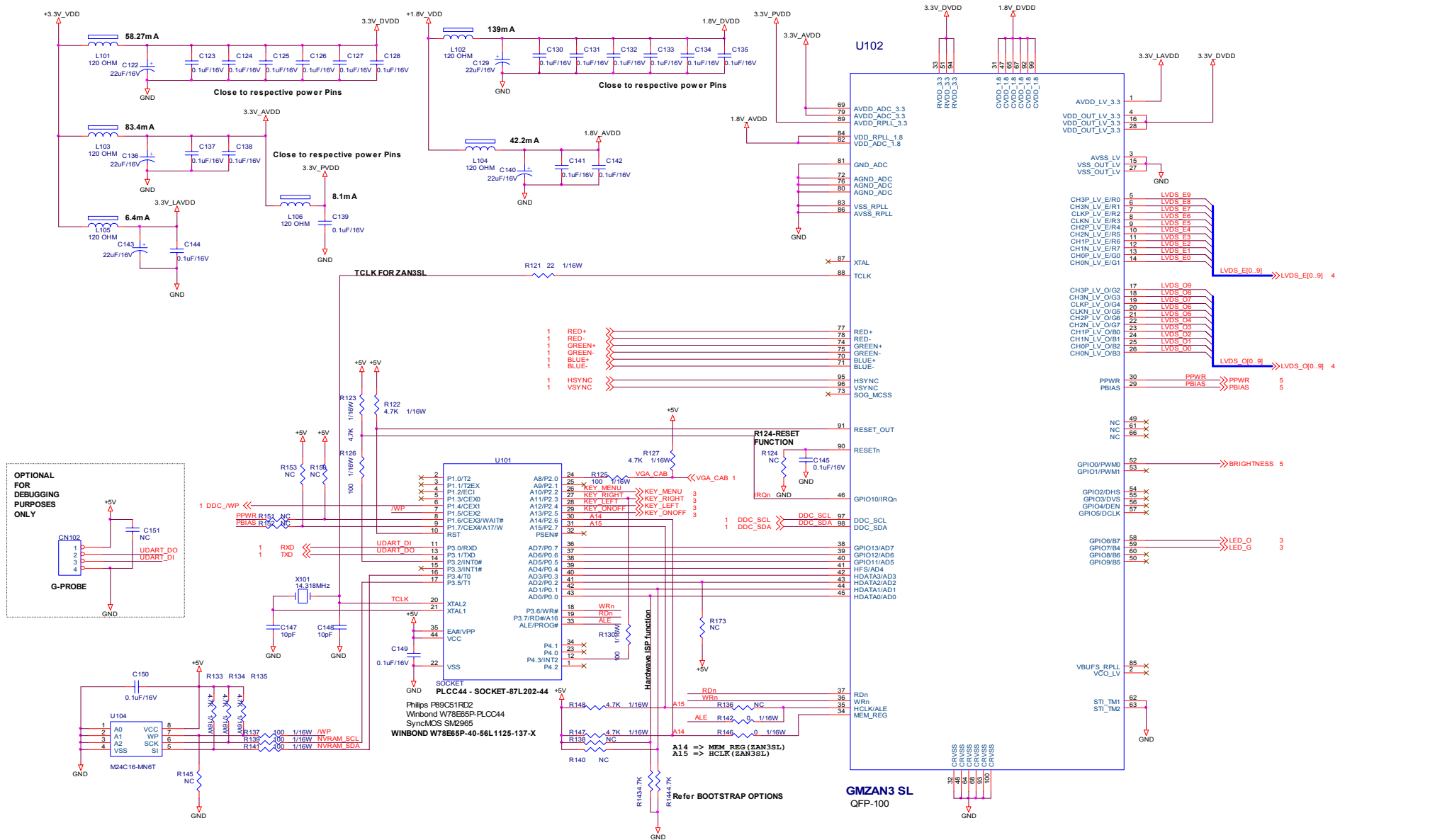

Title		<b>ZAN3 SL &amp; MCU</b>	
Size	Document Number	Rev	
C	<b>Zan3 SL MAIN BOARD</b>	C	
Date:	Friday, February 13, 2004	Sheet	2 of 5

DELL E173FP Service Manual

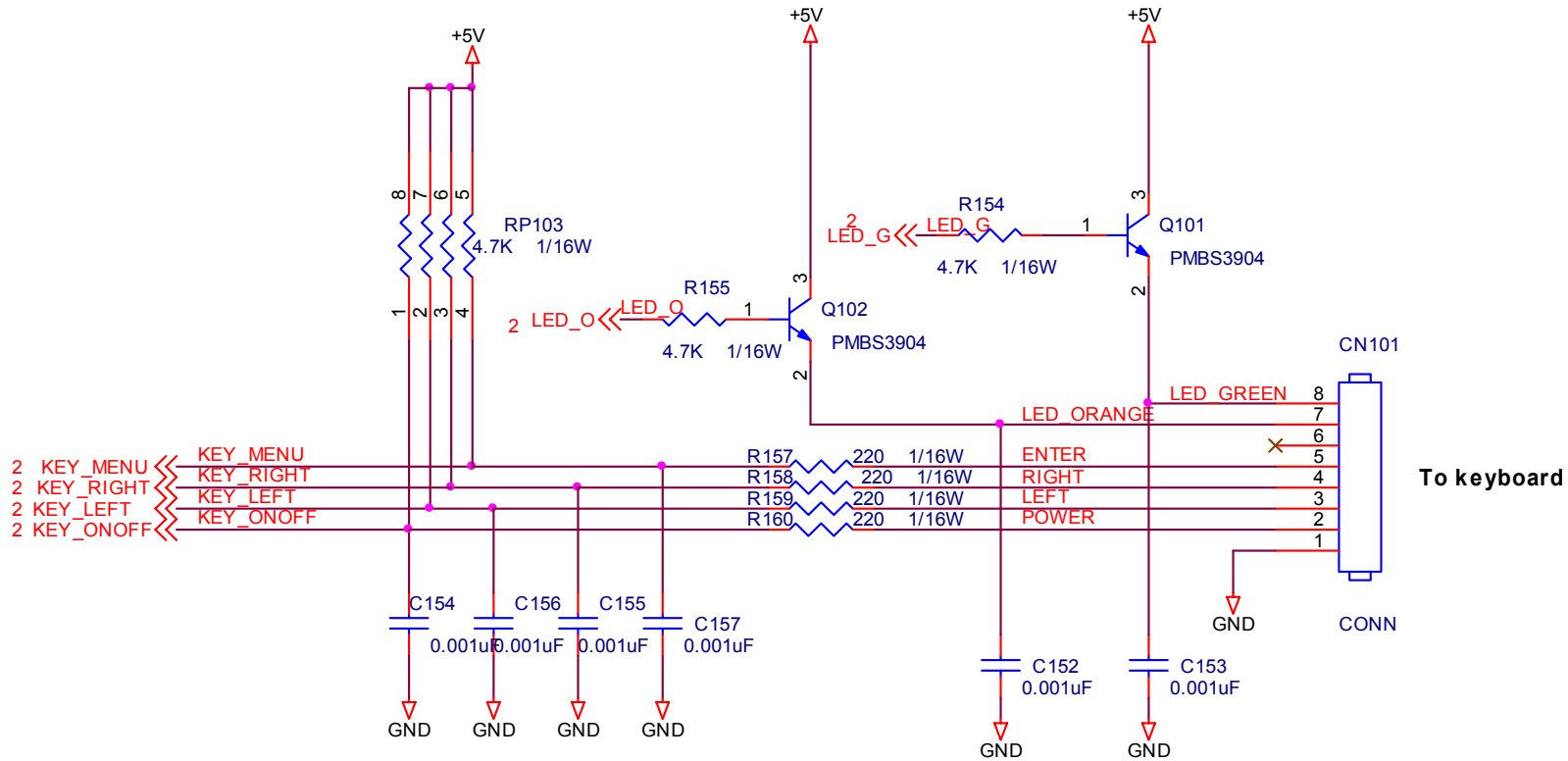

Title		
<b>KEYS CONNECTION</b>		
Size A	Document Number <b>Zan3 SL MAIN BOARD</b>	Rev C
Date:	Friday, February 13, 2004	Sheet 3 of 5

DELL E173FP Service Manual

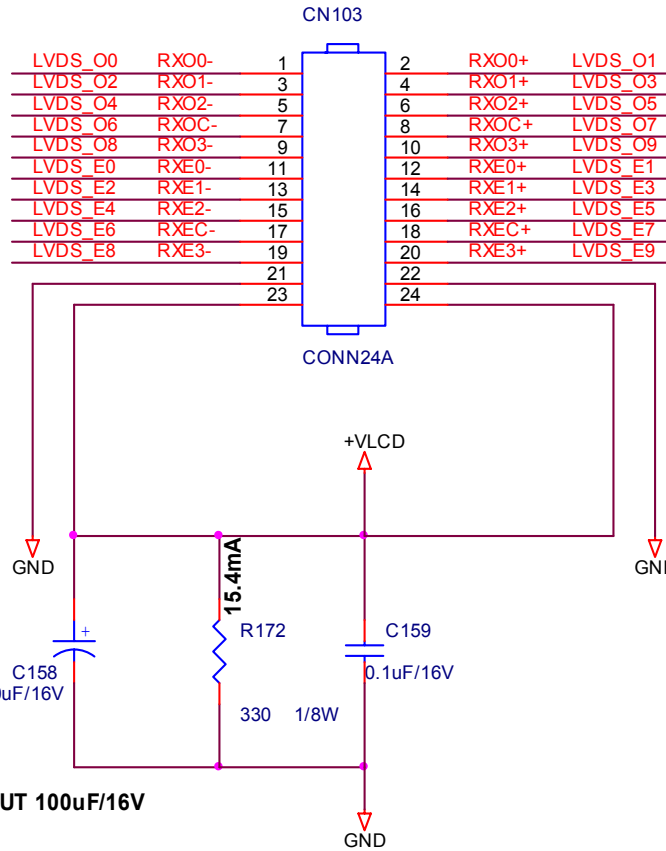
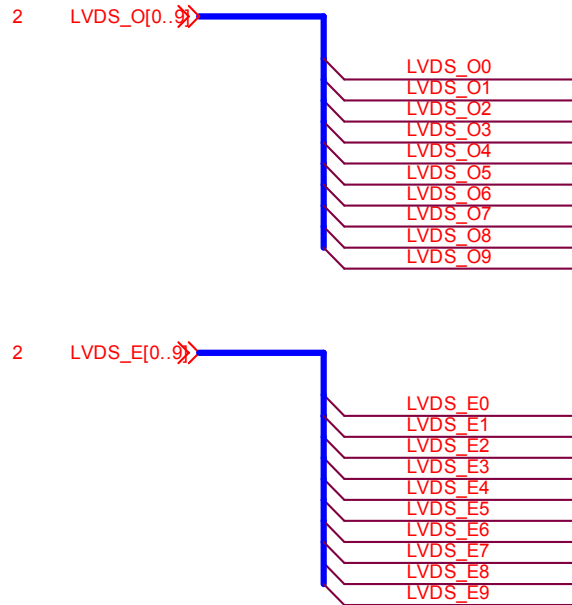

Title		
<b>PANEL INTERFACE</b>		
Size	Document Number	Rev
A	<b>Zan3 SL MAIN BOARD</b>	C
Date:	Friday, February 13, 2004	Sheet 4 of 5

DELL E173FP Service Manual

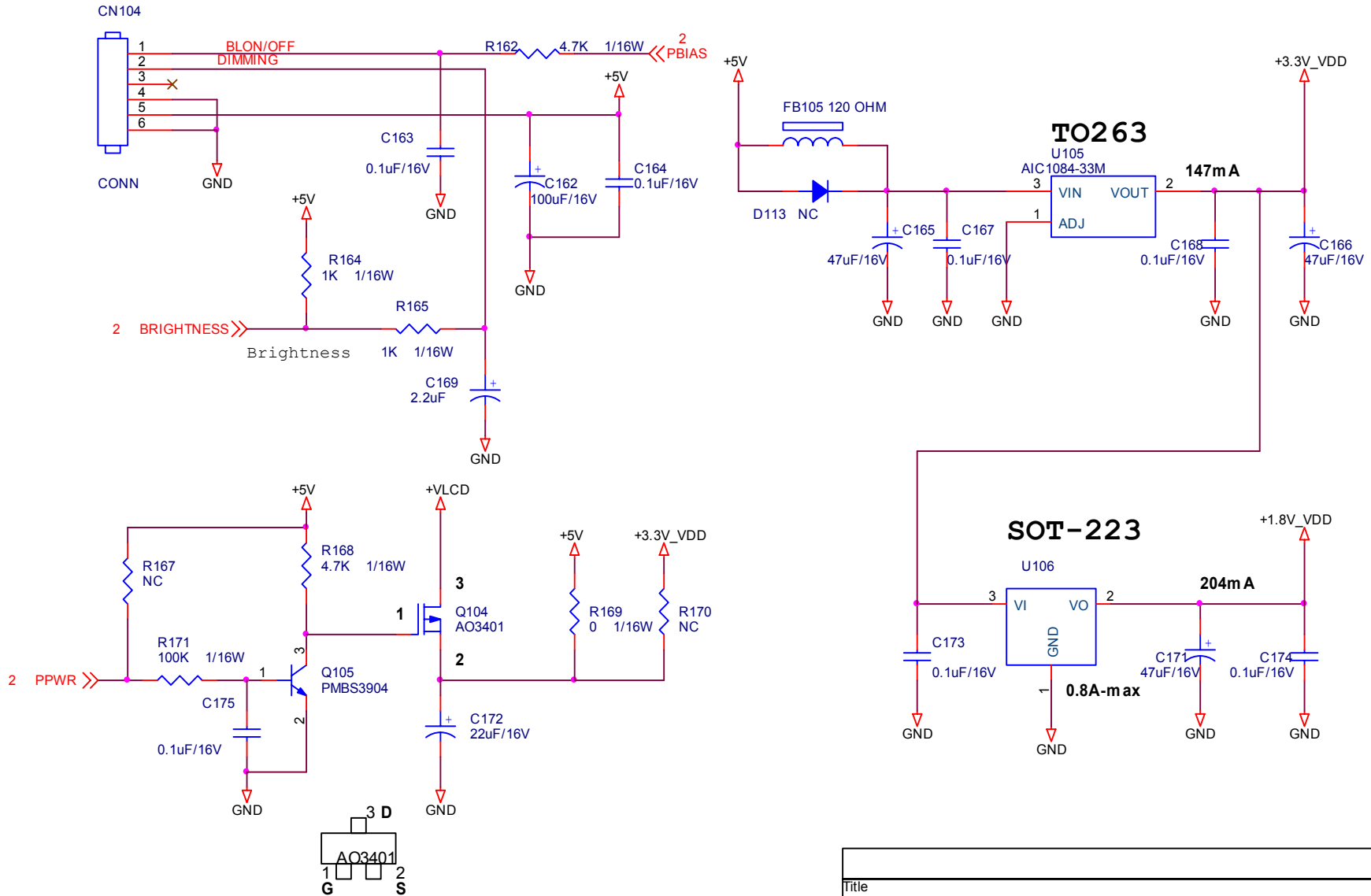

Title		
<b>POWER</b>		
Size A	Document Number <b>Zan3 SL MAIN BOARD</b>	Rev C
Date:	Friday, February 13, 2004	Sheet 5 of 5

6.2 Internal Power Board

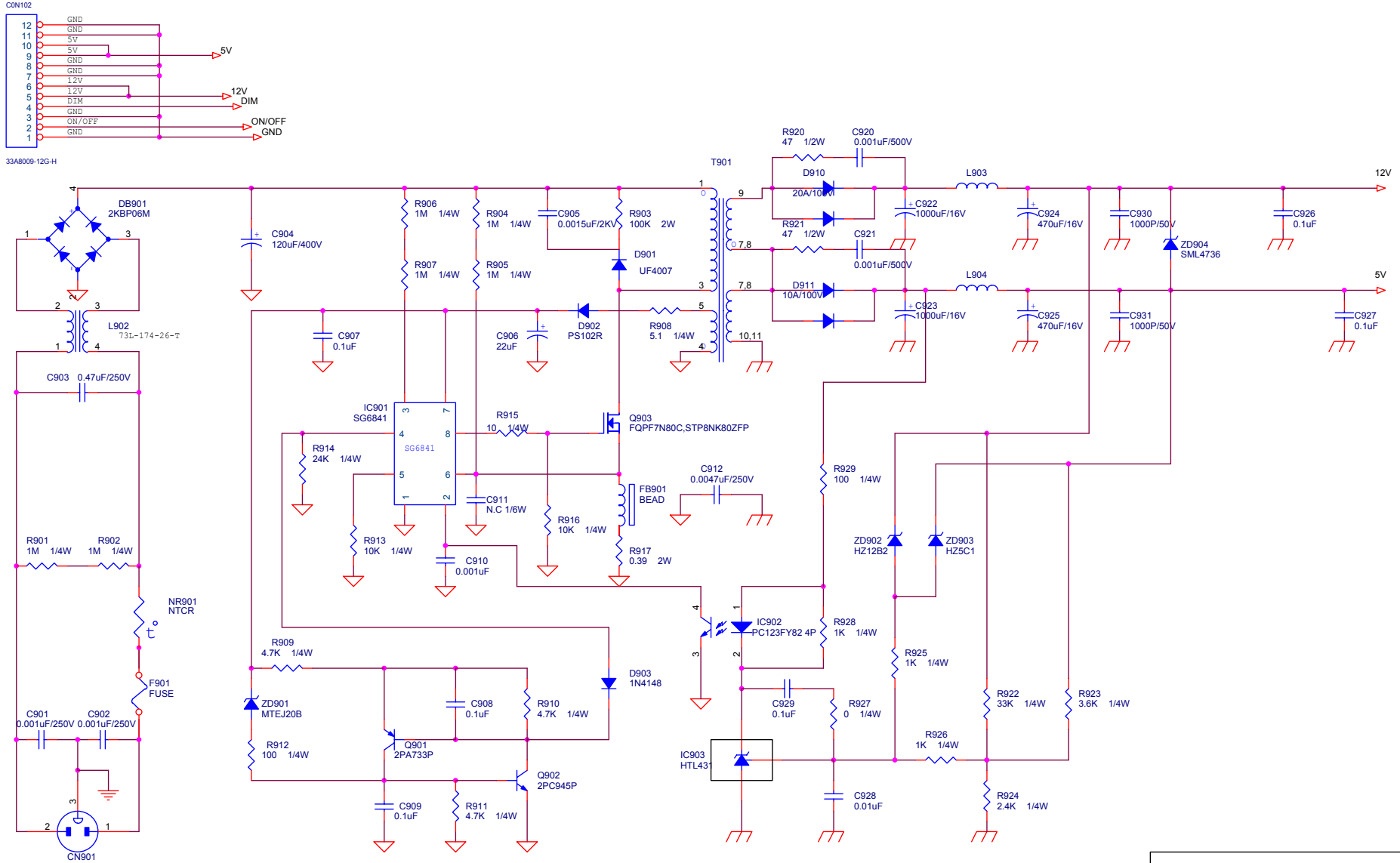

AOC (Top Victory) Electronics Co., Ltd.		
Title		
1. POWER 12V&5V OUTPUT		
Size	Document Number	Rev
	PWPC1742LGD1(715L-1283-1)	A
Date:	Tuesday, March 16, 2004	Sheet 2 of 2

# DELL E173FP Service Manual

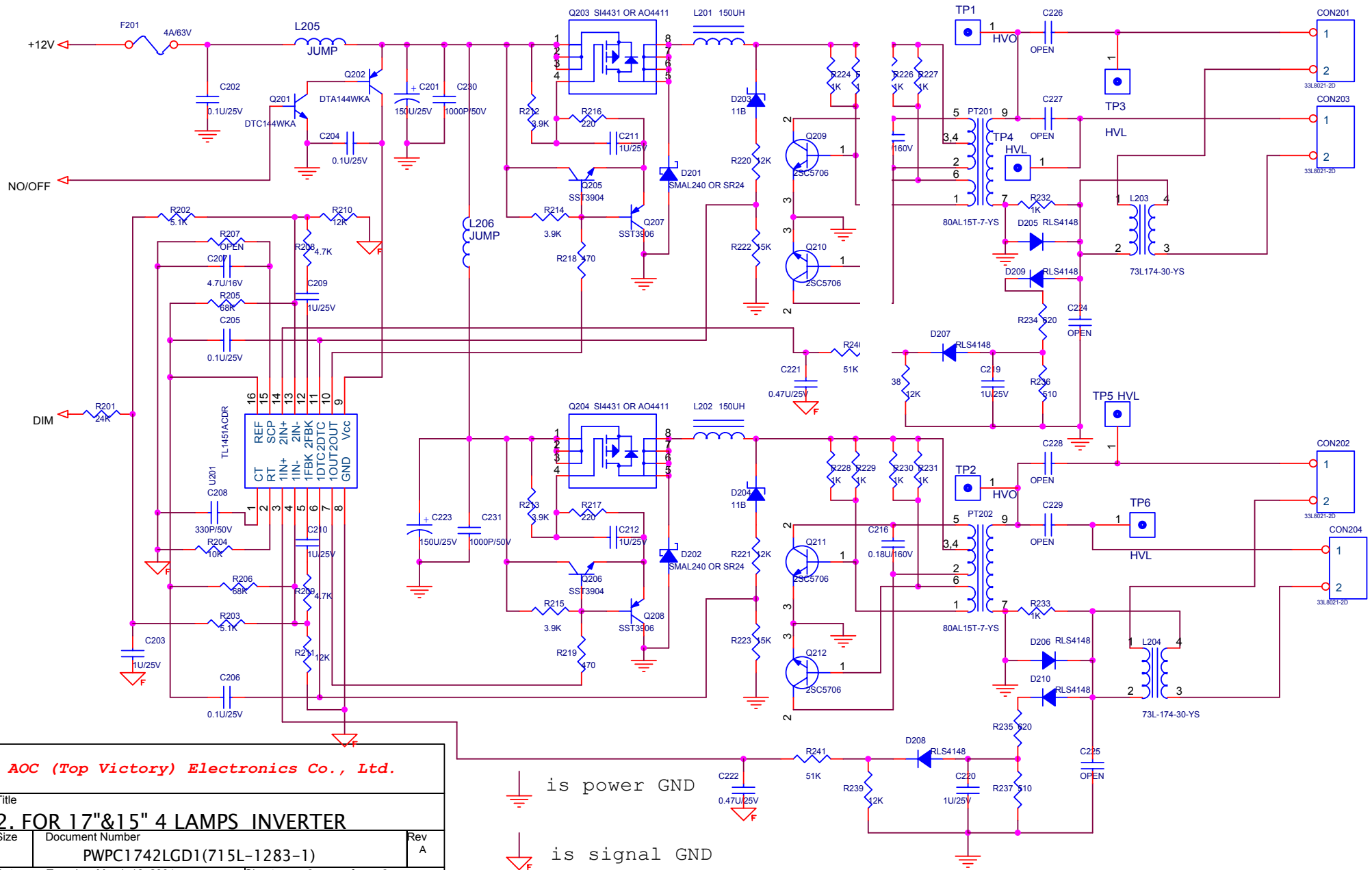

<b>AOC (Top Victory) Electronics Co., Ltd.</b>		
Title		
<b>2. FOR 17" &amp; 15" 4 LAMPS INVERTER</b>		
Size	Document Number	Rev
	<b>PWPC1742LGD1(715L-1283-1)</b>	<b>A</b>
Date:	Tuesday, March 16, 2004	Sheet 2 of 2

is power GND  
 is signal GND



## 7. PCB Layout

### 7.1 Main Board

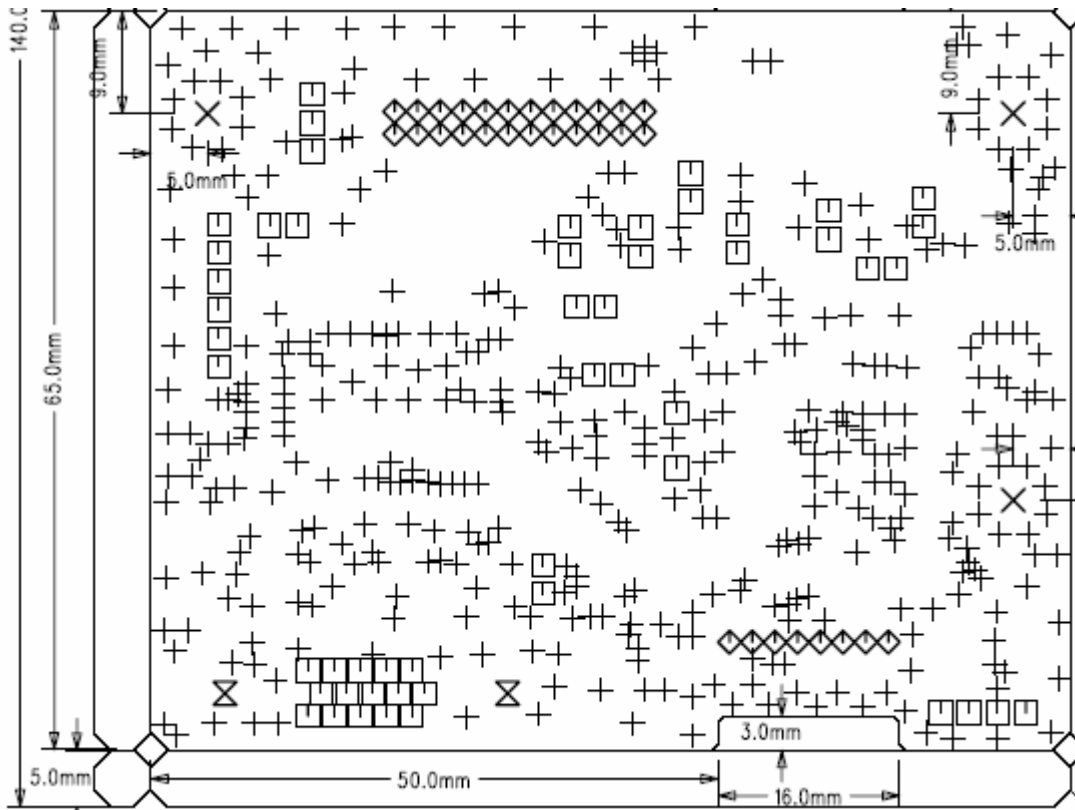
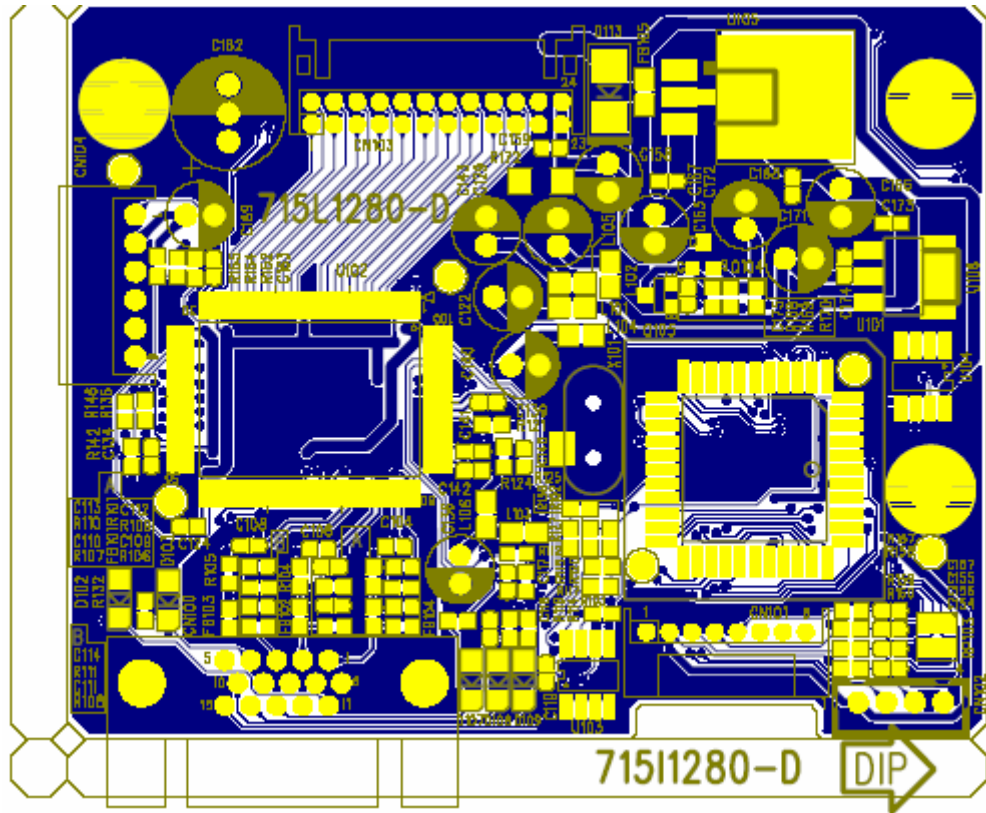

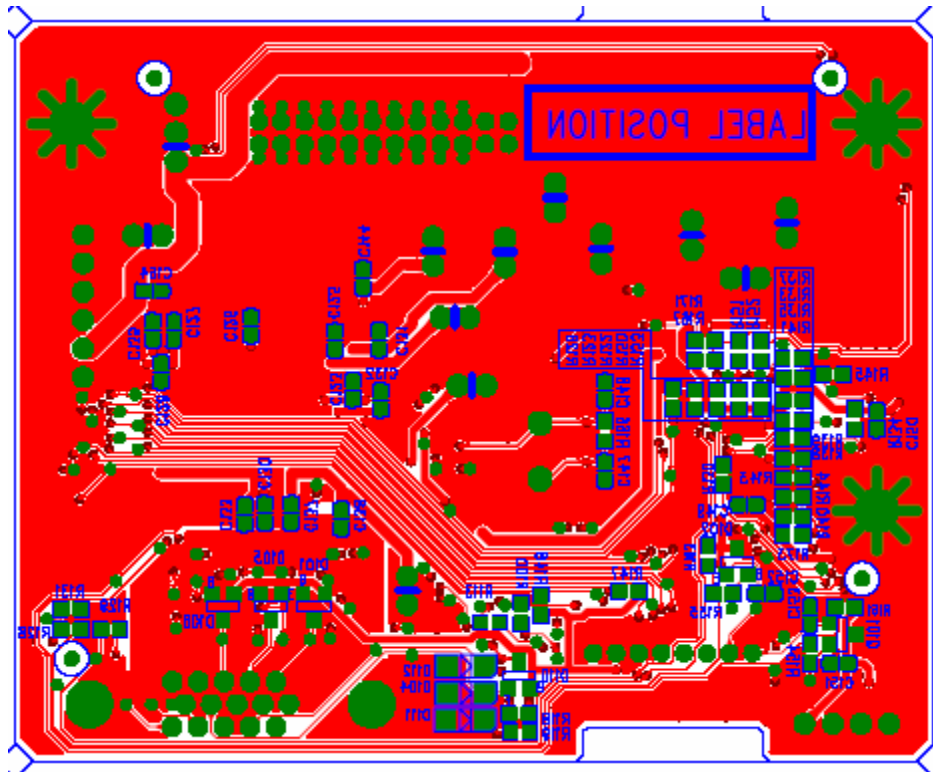

## 7.2 Inverter/Power Board

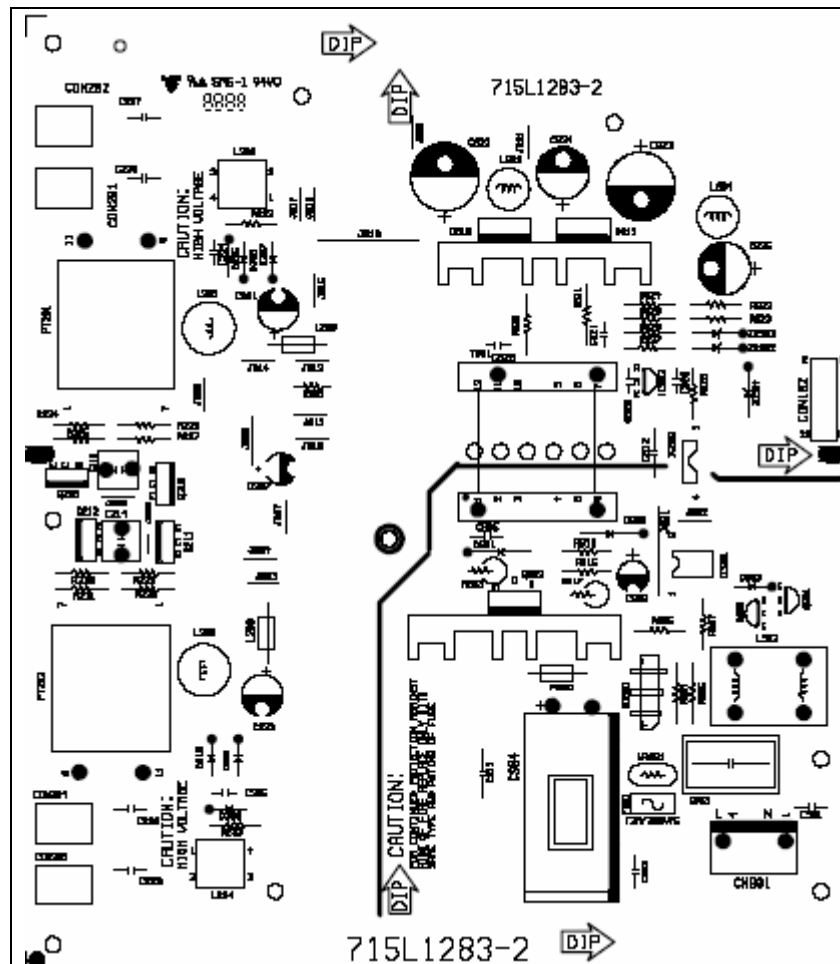

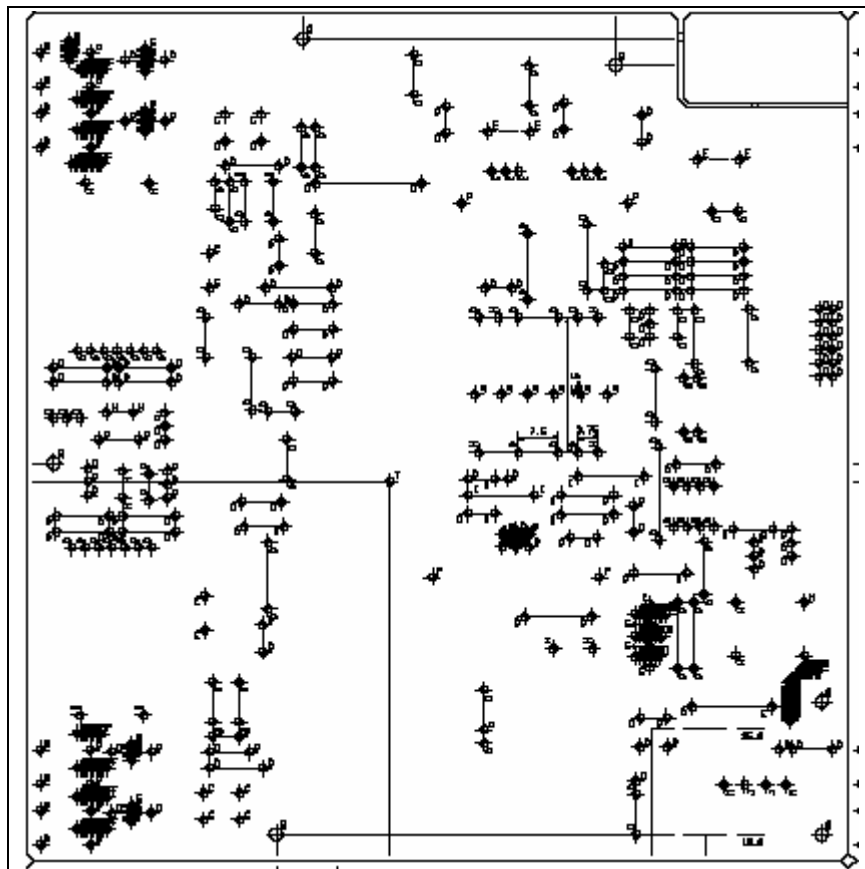
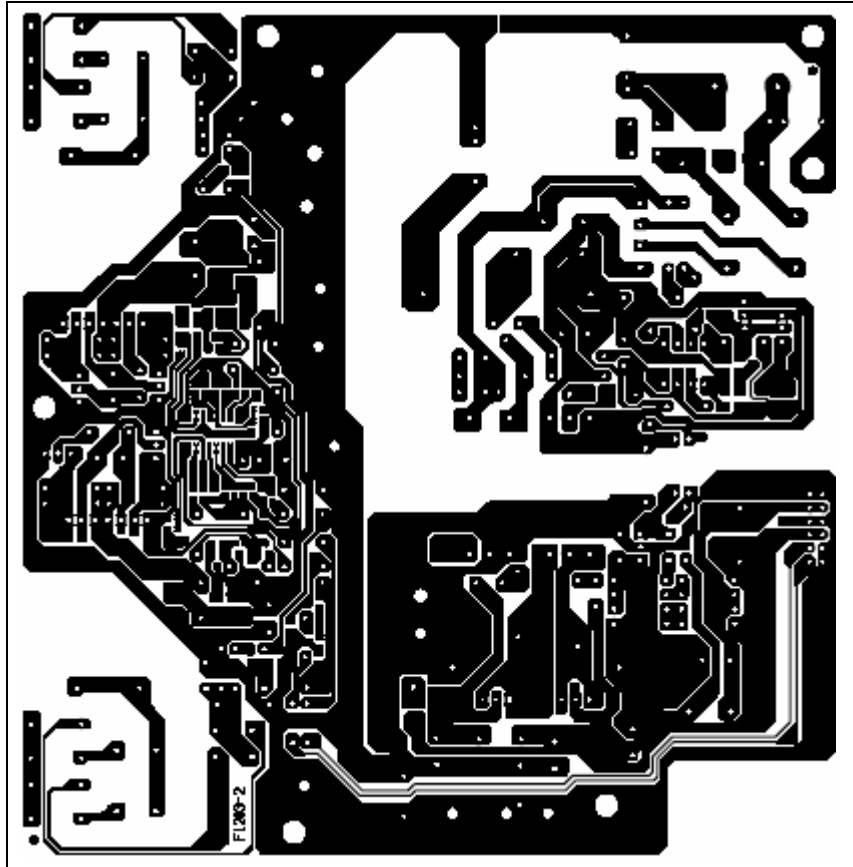

### 7.3 Keypad Board

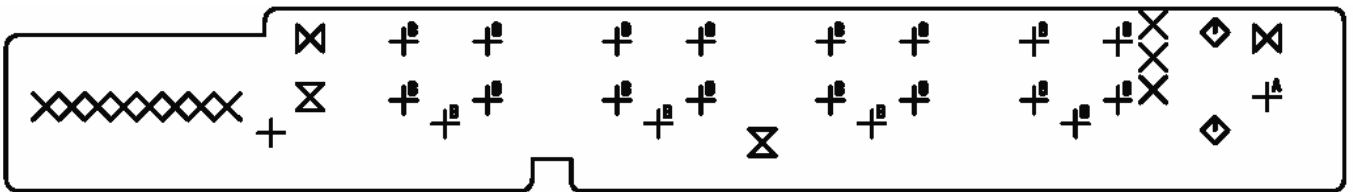
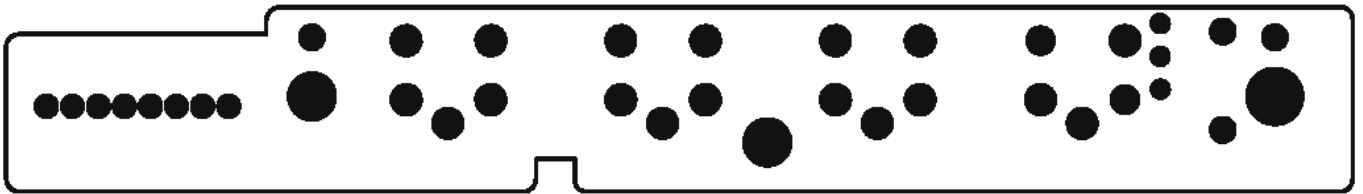
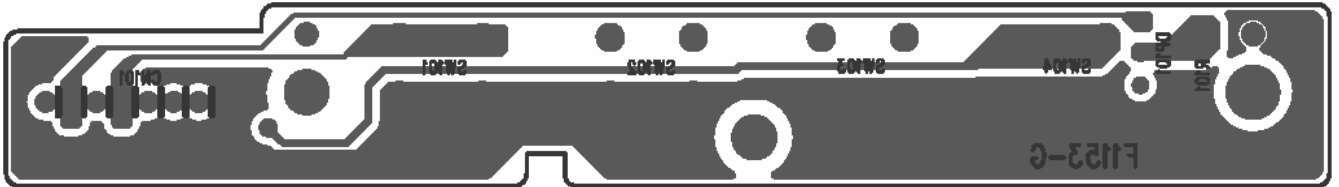
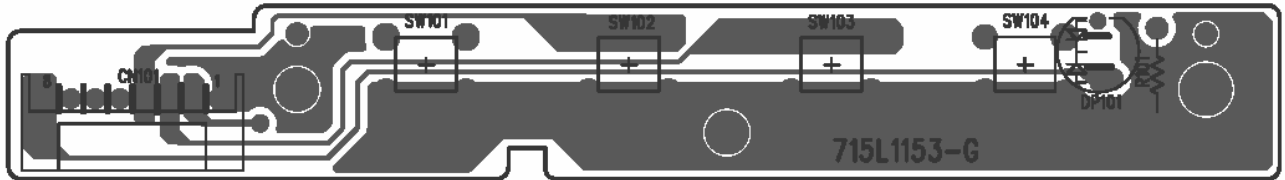

## 8. Maintainability

### 8.1 Equipments and Tools Requirement

- Voltage meter.
- Oscilloscope.
- Pattern Generator.
- DDC Tool with a IBM Compatible Computer.
- Alignment Tool.
- LCD Color Analyzer.
- Service Manual.
- User Manual.

## 8.2 Trouble Shooting

### 8.2.1 Main Board

#### 1) No display

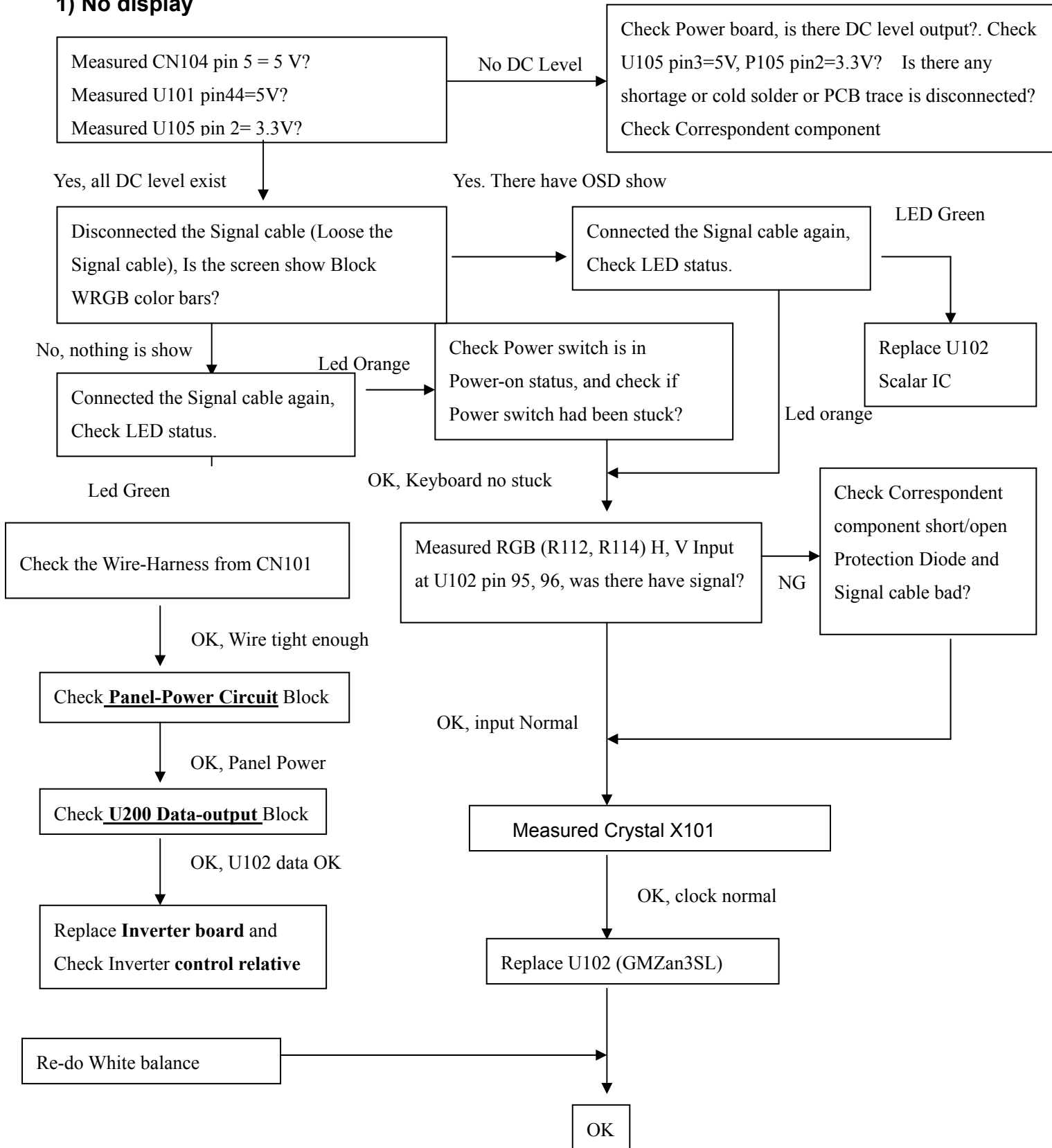

Note: 1. If Replace “**MAIN-BOARD**”, Please re-do “**DDC-content**” programmed & “**WHITE-Balance**”.

2. If Replace “**Inverter Board**” only, Please re-do “**WHITE-Balance**”

## 2) PANEL-POWER CIRCUIT

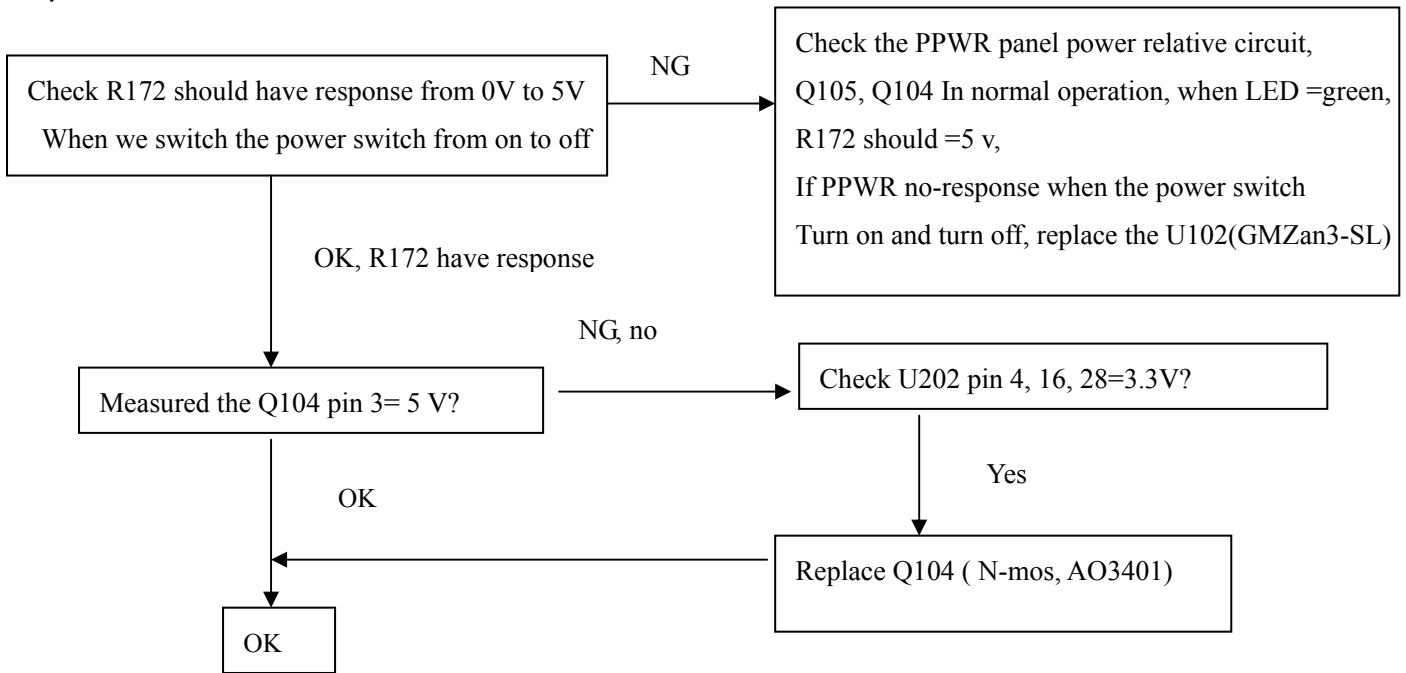

## 3) INVERTER CONTROL RELATIVE CIRCUIT

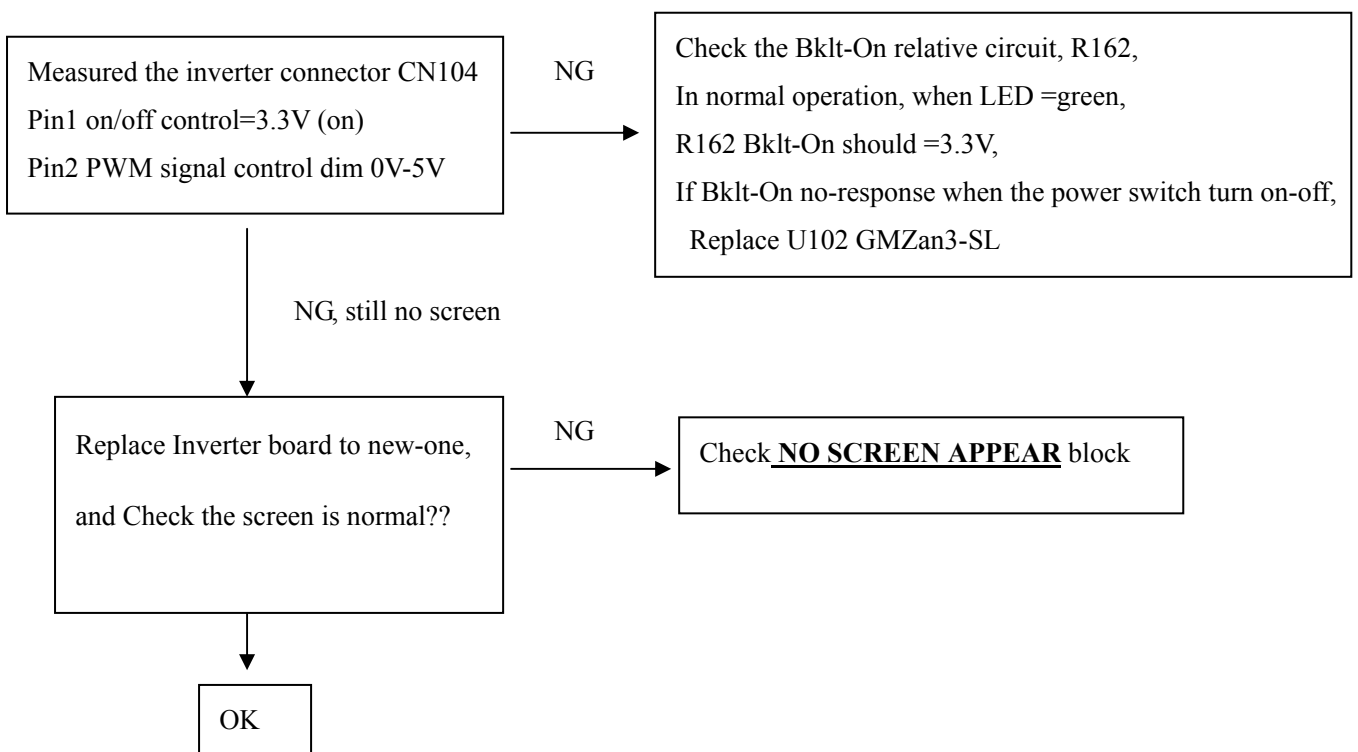

4) U102-DATA OUTPUT

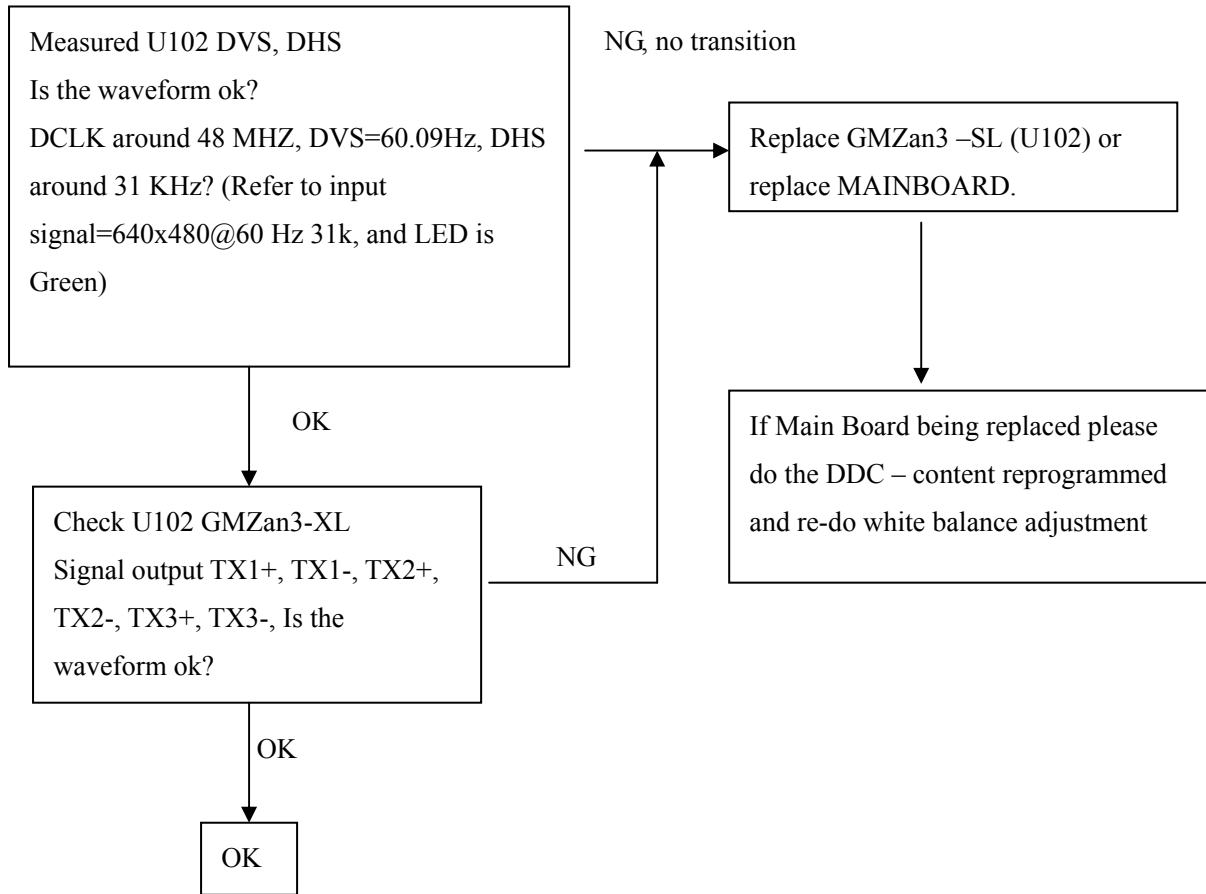

## 8.2.2 Power/Inverter Board

### 1.) No power

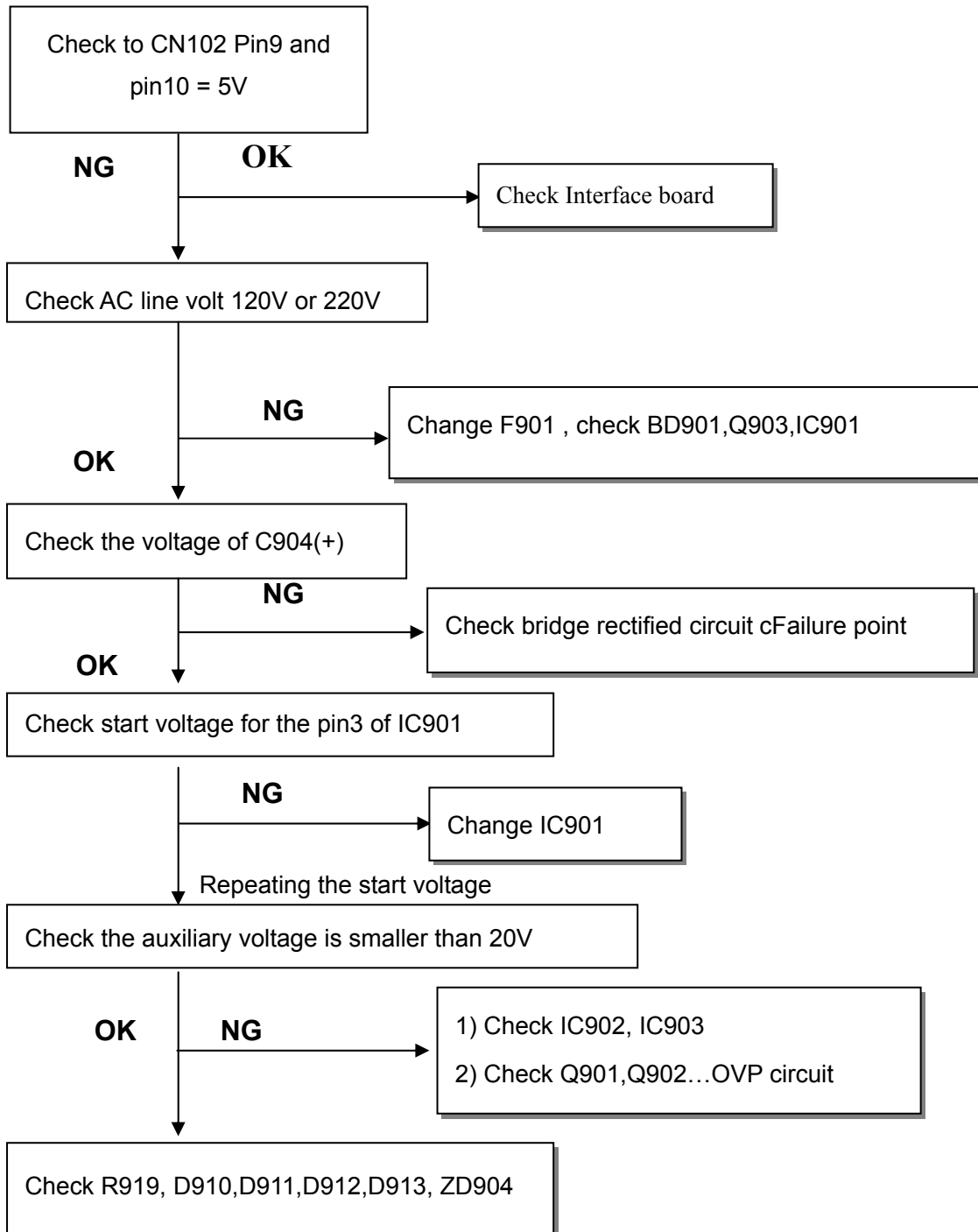



2.) W / LED, No Backlight

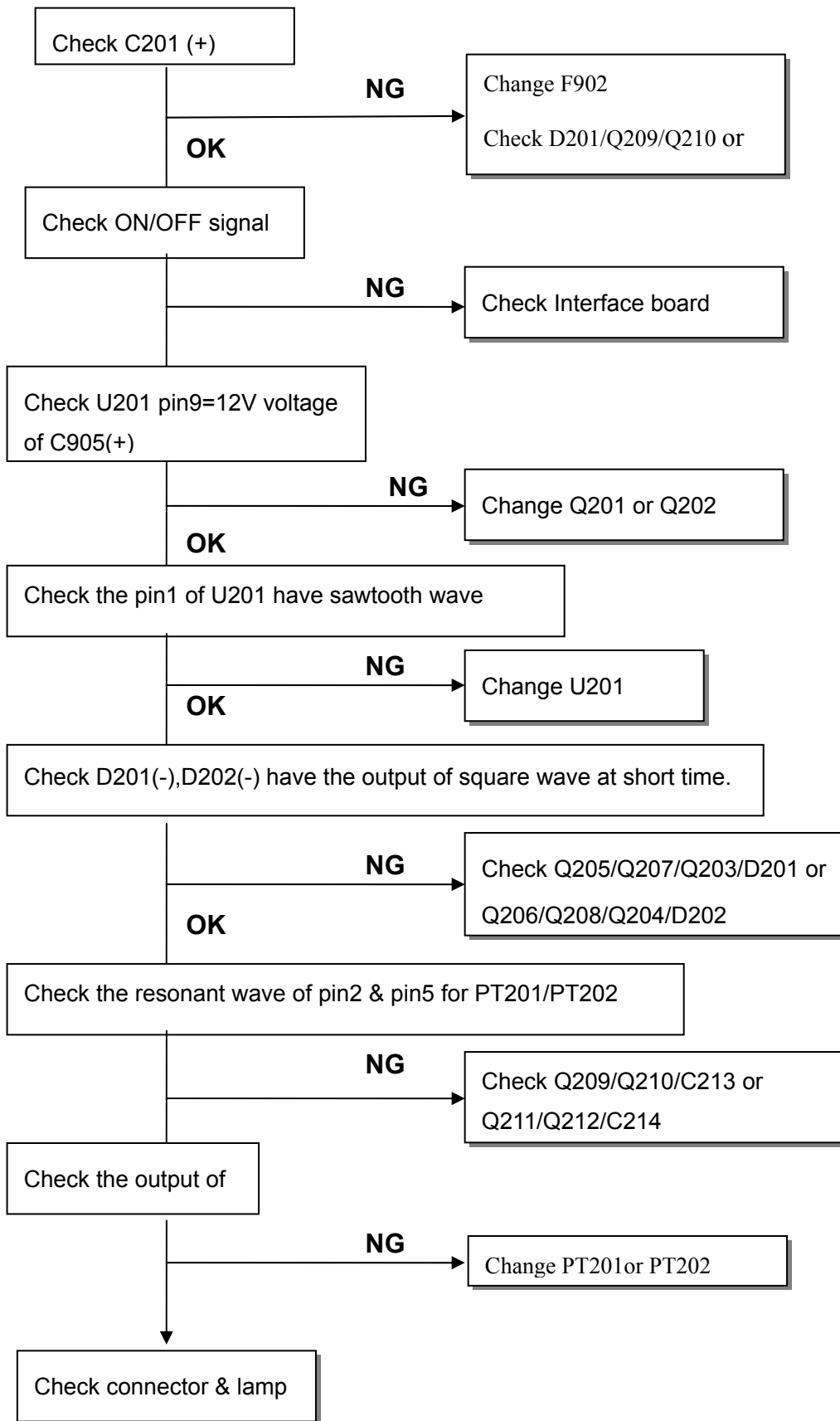

### 8.2.3 Keypad Board

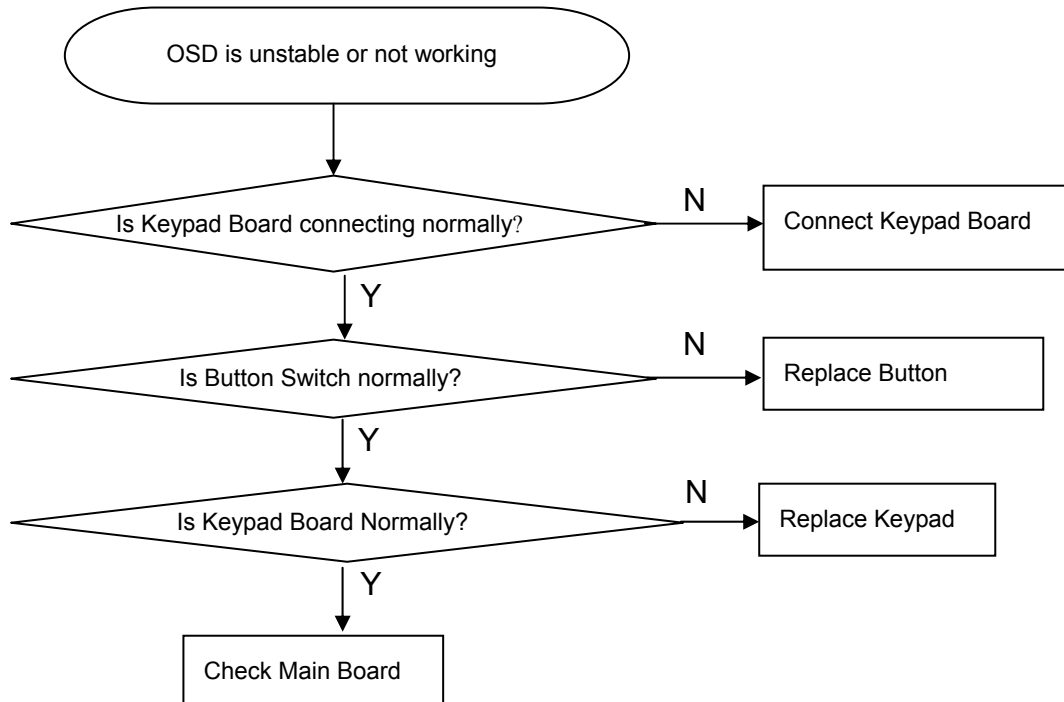

## 9. White-Balance, Luminance adjustment

Approximately 2 Hours should be allowed for warm up before proceeding white balance adjustment.

Before started adjust white balance, please setting the Chroma-7120 **MEM. Channel 1 to 6500<sup>0</sup>K** colors, **MEM. Channel 3 to 9300<sup>0</sup>K** colors, **MEM. Channel 1 to 5700<sup>0</sup>K** (our 9300 parameter is  $x = 296 \pm 10$ ,  $y = 311 \pm 10$ ,  $Y = 180 \pm 10 \text{ cd/m}^2$ , 6500 parameter is  $x = 313 \pm 10$ ,  $y = 329 \pm 10$ ,  $Y = 180 \pm 10 \text{ cd/m}^2$ , and 5700 parameter is  $x = 328 \pm 10$ ,  $y = 344 \pm 10$ ,  $Y = 180 \pm 10 \text{ cd/m}^2$ )

How to setting MEM.channel you can reference to chroma 7120 user guide or simple use “**SC**” key and “**NEXT**” key to modify xyY value and use “**ID**” key to modify the TEXT description

Following is the procedure to do white-balance adjust

Press MENU and AUTO-ADJUST button during press Power button will activate the factory mode,

### Gain adjustment:

Move cursor to “-Factory Setting-” and press MENU key to enter this sub-menu;

Move cursor to “ Factory” and press MENU key;

Move cursor to “ Auto Level” and press MENU key to adjust Gain and Offset automatically;

#### a. Adjust sRGB (6500<sup>0</sup>K) color-temperature

- 1 Switch the chroma-7120 to **RGB-mode** (with press “MODE” button)
- 2 Switch the MEM.channel to Channel 01 (with up or down arrow on chroma 7120)
- 3 The LCD-indicator on chroma 7120 will show  $x = 313 \pm 10$ ,  $y = 329 \pm 10$ ,  $Y = 180 \pm 10 \text{ cd/m}^2$
- 4 In **sRGB** sub-menu, adjust **C** to 192, adjust **L** to 230 ;
- 5 Adjust the RED on OSD window until chroma 7120 indicator reached the value  $R=100$
- 6 Adjust the GREEN on OSD, until chroma 7120 indicator reached  $G=100$
- 7 Adjust the BLUE on OSD, until chroma 7120 indicator reached  $B=100$
- 8 repeat above procedure ( item 5,6,7) until chroma 7120 RGB value meet the tolerance  $=100 \pm 2$

#### b. Adjust Color1 (9300<sup>0</sup>K) color-temperature

- 9 Switch the chroma-7120 to **RGB-mode** (with press “MODE” button)
- 10 Switch the MEM.channel to Channel 03 ( with up or down arrow on chroma 7120 )
- 11 The LCD-indicator on chroma 7120 will show  $x = 296 \pm 10$ ,  $y = 311 \pm 10$ ,  $Y = 180 \pm 10 \text{ cd/m}^2$
- 12 In **Color1** sub-menu, adjust **C** to 192, adjust **L** to 230 ;
- 13 Adjust the RED on OSD window until chroma 7120 indicator reached the value  $R=100$
- 14 Adjust the GREEN on OSD, until chroma 7120 indicator reached  $G=100$
- 15 Adjust the BLUE on OSD, until chroma 7120 indicator reached  $B=100$
- 16 repeat above procedure ( item 5,6,7) until chroma 7120 RGB value meet the tolerance  $=100 \pm 2$

c. Adjust **Color2** (5700<sup>0</sup>K) color-temperature

- 17 Switch the chroma-7120 to **RGB-mode** (with press "MODE" button)
  - 18 Switch the MEM.channel to Channel 03 (with up or down arrow on chroma 7120)
  - 19 The LCD-indicator on chroma 7120 will show  $x = 328 \pm 10$ ,  $y = 344 \pm 10$ ,  $Y = 180 \pm 10 \text{ cd/m}^2$
  - 20 In **Color2** sub-menu, adjust **C** to 192, adjust **L** to 230 ;
  - 21 Adjust the RED on OSD window until chroma 7120 indicator reached the value  $R=100$
  - 22 Adjust the GREEN on OSD, until chroma 7120 indicator reached  $G=100$
  - 23 Adjust the BLUE on OSD, until chroma 7120 indicator reached  $B=100$
  - 24 repeat above procedure ( item 5,6,7) until chroma 7120 RGB value meet the tolerance  $=100 \pm 2$
  - 25 Move cursor to " Exit/Save" sub-menu and press MENU key to save adjust value and exit;
- Turn the POWER-button off to on to quit from factory mode.**

**10. EDIT Content**

## D-SUB Connector (Analog)

	00	01	02	03	04	05	06	07	08	09	A	B	C	D	E	F
0:	00	FF	FF	FF	FF	FF	FF	00	10	AC	0B	A0	43	31	30	30
16:	34	0D	01	03	68	22	1B	78	2A	2D	90	A4	57	4A	9C	25
32:	11	50	54	A5	4B	00	71	4F	81	80	01	01	01	01	01	01
48:	01	01	01	01	01	01	30	2A	00	98	51	00	2A	40	30	70
64:	13	00	78	2D	11	00	00	1E	00	00	00	FF	00	36	34	31
80:	38	30	33	39	43	30	30	31	43	0A	00	00	00	FD	00	38
96:	4C	1F	50	0E	00	0A	20	20	20	20	20	20	00	00	00	FC
112:	00	44	45	4C	4C	20	45	31	37	33	46	50	63	20	00	49

Note: Byte 0C, 0D, 0E, 0F means Serial No. Byte 10, 11 means Manufacture Time. Byte 7F means checksum

## 11. ISP (In System Program) User Manual

### 11.1. Connect ISP Writer preparation action :

Connect RXD and TXD of PC to RXD (P3.0) and TXD (P3.1) of CPU through RS-232.

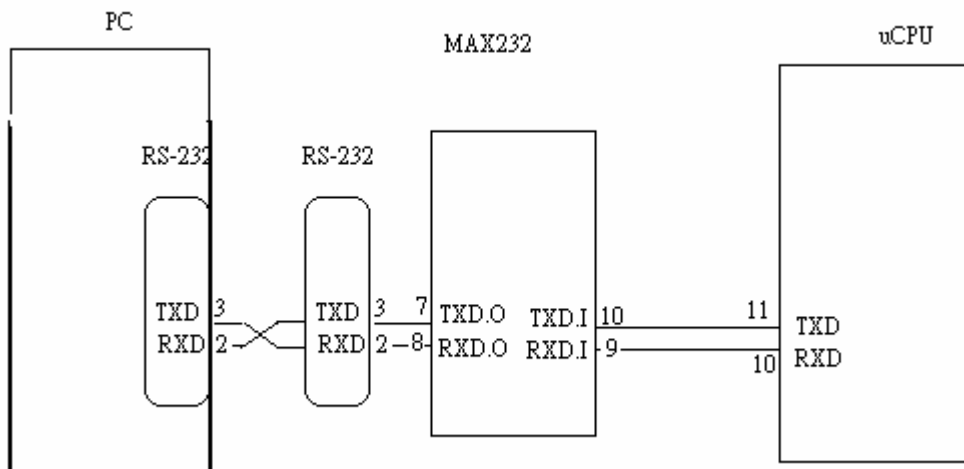

- a. There are two ways to entering Reboot Mode. The settings for Reboot Mode is as follow :
  - ☆Both P2.6、P2.7 are LOW and RESET pin is HI.
  - ☆P4.3 is LOW and RESET pin is HI .

### 11.2. To Use ISP WRITER

Press the “-“ key at front bezel and plug the AC power cord in, then the MCU enter ISP mode;

- a. You will enter the window as follow after executing the ispwriter.exe file.

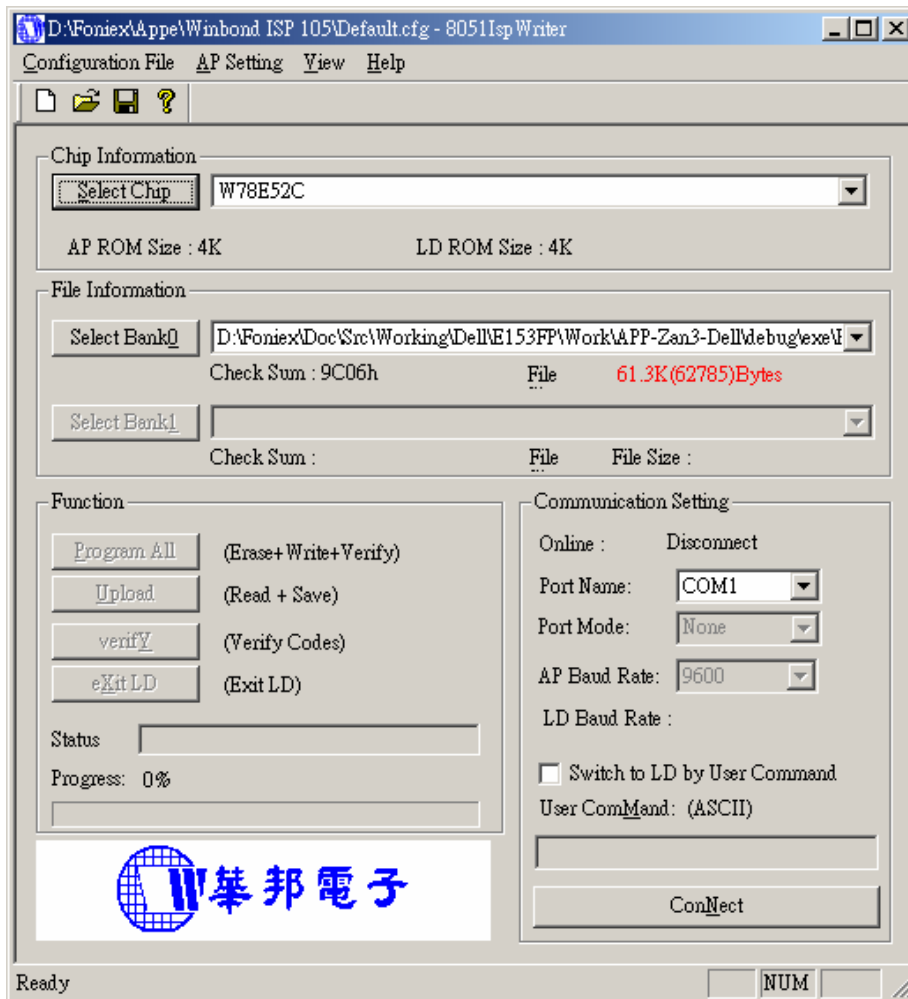

- b. Click the “Select Chip” button, and choose the type you’re going to program.

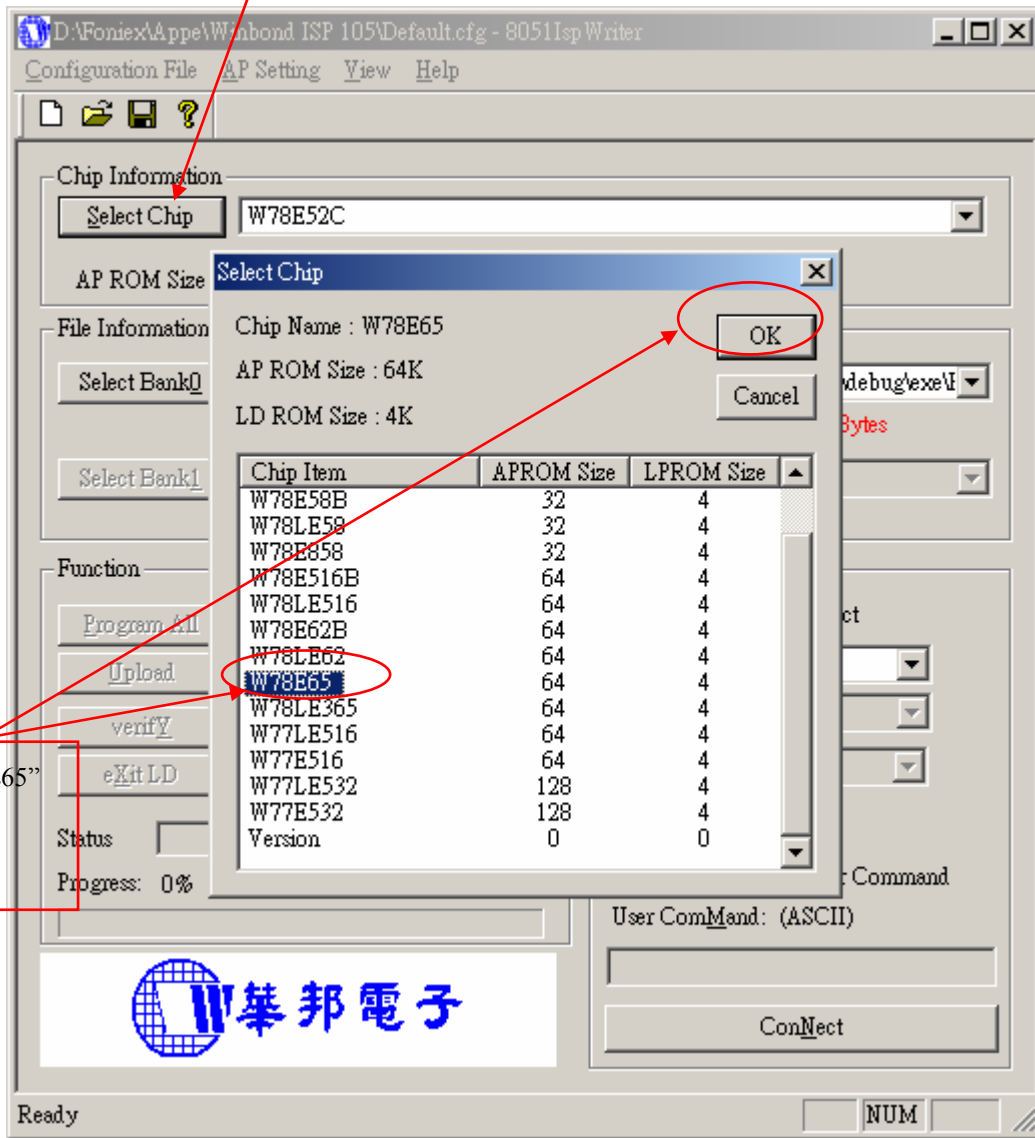

- c. Click the “Select Bank0” button and selecting a file which a binary Format required.

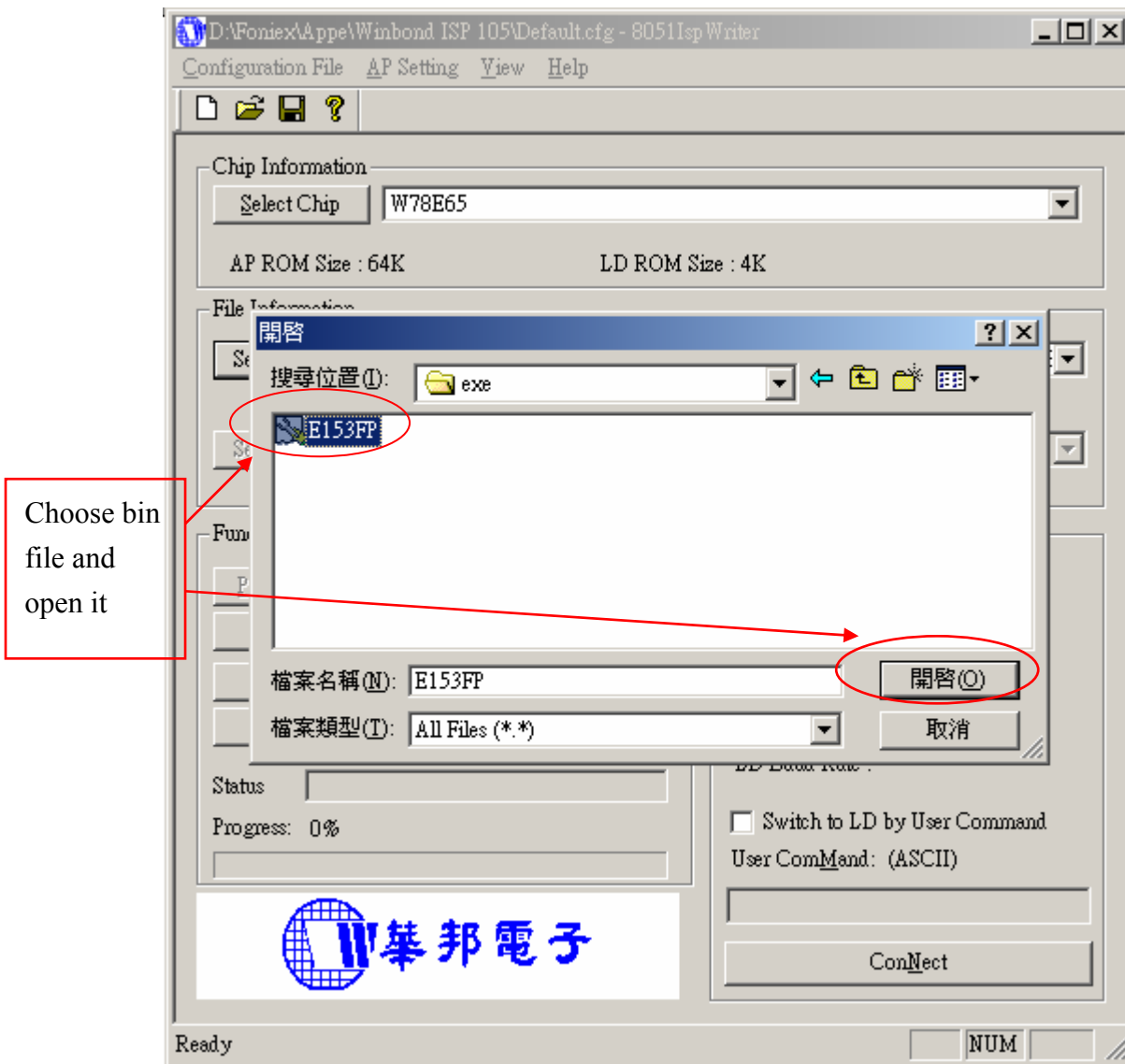



d. Select the communication Setting: Port Name

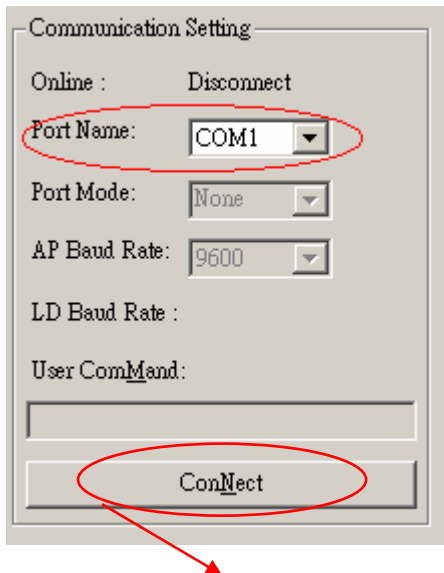

e. Click the “ConNect” button.

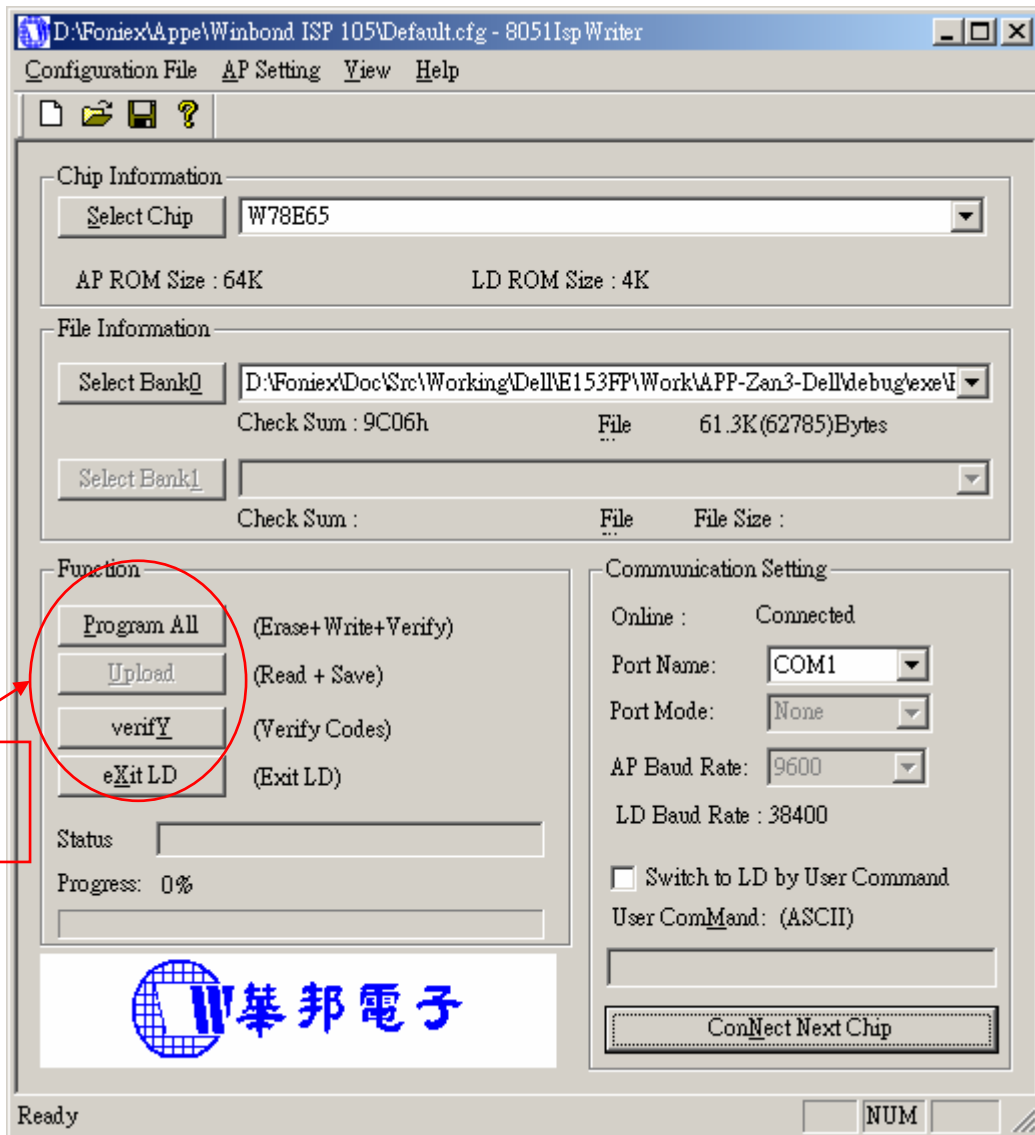

f. Click “Program all” to start programming.

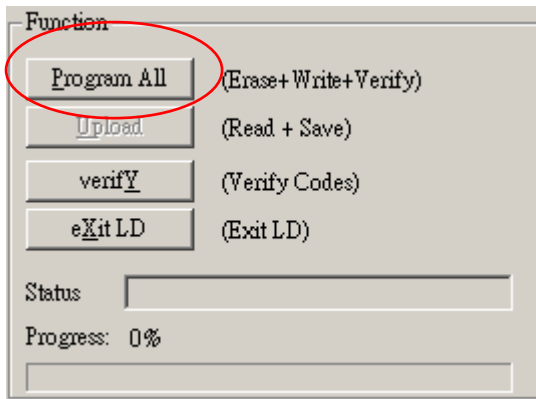

### 11.3. Executing ISP

a. Click “Program All” button that will execute erase and program and verify. Then you can get the window as follow, and click “OK” to complete ISP process.

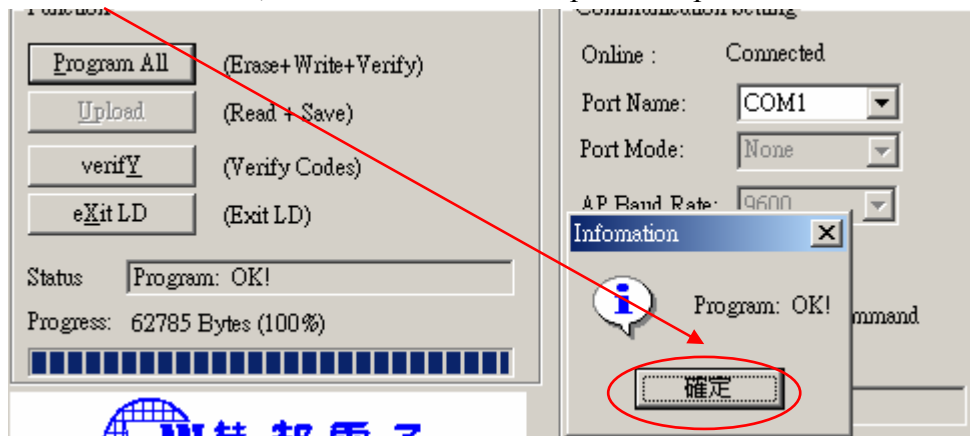

b. Complete the ISP process, click “eXit LD” button to reset monitor.

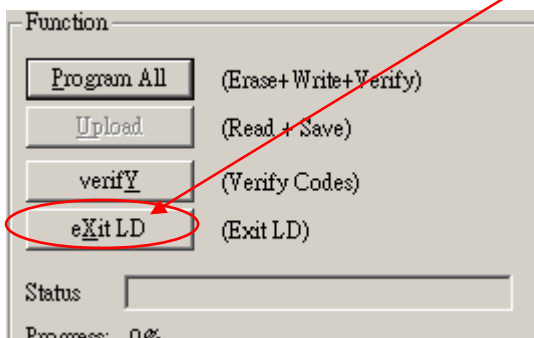

## 12. Bill Of Material List

Location	Part Number	Description	Qty.	Unit
	CBPC780KGLDD	CONVERSION BOARD	1	PCS
	KEPC780KED1	KEY BOARD	1	PCS
	PWPC1742LGD1	POWER BOARD	1	PCS
	11L6036 1	SPACER SUPPORT SCC-24	1	PCS
	15L8054 2	MAIN FRAME	1	PCS
	23L3178700 1A	LOGO	1	PCS
	33L4669 GV C	POWER BUTTON	1	PCS
	33L4670 GV T	KEY PAD	1	PCS
	34L1367AY2 T	BEZEL	1	PCS
	34L1368 Y2 T	REAR COVER	1	PCS
	40L 152509	RECYCLE LABEL	0	PCS
	40L 152512	RECYCLE LABEL	0	PCS
	40L 154501 16444	HI-POT	1	PCS
	40L 190700 1A6310	ID LABEL	1	PCS
	40L 459700 1A6444	DELL S/N LABEL	1	PCS
	40L 581 267046036	SHIPPING LABEL	0.01	PCS
	40L 581700 3A6444	CARTON LABEL	1	PCS
	41L7800700 2A	QSG	1	PCS
	44L3733 1	EPS	1	PCS
	44L3733 2	EPS	1	PCS
	44L3733700 1A	CARTON	1	PCS
	44L6000 4 6B	SPACE PAPER	0.0077	PCS
	45L 77512 F6863	BARCODE RIBBOR	18	MM
	45L 88607DE6	PE BAG FOR MONITOR	1	PCS
	52L 1186	SMALL TAPE	8	CM
	52L6020 2DE4	FILM PROTECT	1	PCS
	52L6022 1500	SMALL TAPE	12	CM
	70L1700700 1A	CD MANUAL	1	PCS
	85L 672 1	SHIELD	1	PCS
	85L 673 1	SHIELD-INVERTER	1	PCS
	89L1738GAA 16	SIGNAL CABLE	1	PCS
	89L401A18NHRA	POWER CORD	1	PCS
	95L8018 30529	WIRE HARNESS	1	PCS
	M1L1140 6128	SCREW 4X6	1	PCS
	M1L1430 6128	SCREW M3X6	4	PCS
	M1L1430 6128	SCREW M3X6	5	PCS
	M1L1430 6128	SCREW M3X6	3	PCS

	M1L2640 10225	SCREW	4	PCS
	Q1L 330 8 47	SCREW 3X8mm	3	PCS
	705L 780 87 DL	CN901 ASS' Y	1	PCS
	705L780KB34 79	BACK COVER ASS' Y	1	PCS
	750LLG70E01 3	LVDS PANEL LM170E01-A5N	1	PCS
	44L3231511	旧繁體粗	2	PCS
	44L3231512	旧繁體粗	3	PCS
-----	-----	-----	-----	-----
PARENT NO:	CBPC780KGLDD	CONVERSION BOARD		
-----	-----	-----	-----	-----
	AIC780KSLDD	MAIN BOARD	1	PCS
CN101	33L3802 8H	WAFER 8P RIGHT ANGLE PI	1	PCS
CN104	33L8013 6 H	6P PLUG R/A	1	PCS
CN103	33L8027 24 H	CONN W TO B12P*2 P*2.0	1	PCS
U101A	56L1125137LD3	W78E65P-40 BY WINBOND	1	PCS
C158	67L309V101 3	100UF 16V	1	PCS
C162	67L309V101 3	100UF 16V	1	PCS
C122	67L309V220 3	22UF +-20% 16V	1	PCS
C129	67L309V220 3	22UF +-20% 16V	1	PCS
C136	67L309V220 3	22UF +-20% 16V	1	PCS
C140	67L309V220 3	22UF +-20% 16V	1	PCS
C143	67L309V220 3	22UF +-20% 16V	1	PCS
C172	67L309V220 3	22UF +-20% 16V	1	PCS
C169	67L309V229 7	2.2UF +-20% 50V	1	PCS
C165	67L309V470 3	47UF 16V 85C	1	PCS
C166	67L309V470 3	47UF 16V 85C	1	PCS
C171	67L309V470 3	47UF 16V 85C	1	PCS
CN100	88L 35315F H	D-SUB 15PIN	1	PCS
X101	93L 22 53	CRYSTAL 14.318MHzHC-49U	1	PCS
-----	-----	-----	-----	-----
PARENT NO:	AIC780KSLDD	MAIN BOARD		
-----	-----	-----	-----	-----
U102	56L 562 58	GMZAN3/SL (AC)	1	PCS
U106	56L 563 27	AIC1117A-18CY SOT-223	1	PCS
U106	56L 56327A	AP1117E18A SOT223-3L	0	PCS
U105	56L 585 4	AIC1117-33CY	1	PCS
U105	56L 585 4A	AP1117E33A	0	PCS
U103	56L1133 34	M24C02-WMN6T SMT	1	PCS
U104	56L1133 56	M24C16-WMN6T/W SO-8	1	PCS
Q101	57L 417 4	PMBS3904/PHILIPS-SMT (04	1	PCS

Q102	57L 417 4	PMBS3904/PHILIPS-SMT(04	1	PCS
Q105	57L 417 4	PMBS3904/PHILIPS-SMT(04	1	PCS
Q104	57L 763 1	A03401 SOT23 BY AOS(A1)	1	PCS
Q104	57L 763 1A	AP2305N	0	PCS
RP103	61L 125472 8	CHIP AR 8P4R 4.7K OHM+-	1	PCS
FB104	61L0603000	CHIPR 00HM +-5% 1/10W	1	PCS
R142	61L0603000	CHIPR 00HM +-5% 1/10W	1	PCS
R146	61L0603000	CHIPR 00HM +-5% 1/10W	1	PCS
R169	61L0603000	CHIPR 00HM +-5% 1/10W	1	PCS
R102	61L0603101	CHIPR 100 OHM +-5% 1/10	1	PCS
R109	61L0603101	CHIPR 100 OHM +-5% 1/10	1	PCS
R110	61L0603101	CHIPR 100 OHM +-5% 1/10	1	PCS
R111	61L0603101	CHIPR 100 OHM +-5% 1/10	1	PCS
R119	61L0603101	CHIPR 100 OHM +-5% 1/10	1	PCS
R120	61L0603101	CHIPR 100 OHM +-5% 1/10	1	PCS
R125	61L0603101	CHIPR 100 OHM +-5% 1/10	1	PCS
R126	61L0603101	CHIPR 100 OHM +-5% 1/10	1	PCS
R128	61L0603101	CHIPR 100 OHM +-5% 1/10	1	PCS
R129	61L0603101	CHIPR 100 OHM +-5% 1/10	1	PCS
R130	61L0603101	CHIPR 100 OHM +-5% 1/10	1	PCS
R137	61L0603101	CHIPR 100 OHM +-5% 1/10	1	PCS
R139	61L0603101	CHIPR 100 OHM +-5% 1/10	1	PCS
R141	61L0603101	CHIPR 100 OHM +-5% 1/10	1	PCS
R164	61L0603102	CHIPR 1K OHM +-5% 1/10W	1	PCS
R165	61L0603102	CHIPR 1K OHM +-5% 1/10W	1	PCS
R171	61L0603104	CHIPR 100K OHM +-5% 1/1	1	PCS
FB101	61L0603220	CHIPR 22 OHM+-5% 1/10W	1	PCS
FB102	61L0603220	CHIPR 22 OHM+-5% 1/10W	1	PCS
FB103	61L0603220	CHIPR 22 OHM+-5% 1/10W	1	PCS
R121	61L0603220	CHIPR 22 OHM+-5% 1/10W	1	PCS
R157	61L0603221	CHIPR 220 OHM+-5% 1/10W	1	PCS
R158	61L0603221	CHIPR 220 OHM+-5% 1/10W	1	PCS
R159	61L0603221	CHIPR 220 OHM+-5% 1/10W	1	PCS
R160	61L0603221	CHIPR 220 OHM+-5% 1/10W	1	PCS
R115	61L0603222	CHIPR 2.2K OHM+-5% 1/10	1	PCS
R116	61L0603222	CHIPR 2.2K OHM+-5% 1/10	1	PCS
R131	61L0603272	CHIP 2.7K OHM 1/10W	1	PCS
R132	61L0603272	CHIP 2.7K OHM 1/10W	1	PCS
R112	61L0603470	CHIPR 47 OHM +-5% 1/10W	1	PCS
R114	61L0603470	CHIPR 47 OHM +-5% 1/10W	1	PCS

R122	61L0603472	CHIPR 4.7K OHM +-5% 1/1	1	PCS
R123	61L0603472	CHIPR 4.7K OHM +-5% 1/1	1	PCS
R127	61L0603472	CHIPR 4.7K OHM +-5% 1/1	1	PCS
R133	61L0603472	CHIPR 4.7K OHM +-5% 1/1	1	PCS
R134	61L0603472	CHIPR 4.7K OHM +-5% 1/1	1	PCS
R135	61L0603472	CHIPR 4.7K OHM +-5% 1/1	1	PCS
R143	61L0603472	CHIPR 4.7K OHM +-5% 1/1	1	PCS
R144	61L0603472	CHIPR 4.7K OHM +-5% 1/1	1	PCS
R147	61L0603472	CHIPR 4.7K OHM +-5% 1/1	1	PCS
R148	61L0603472	CHIPR 4.7K OHM +-5% 1/1	1	PCS
R154	61L0603472	CHIPR 4.7K OHM +-5% 1/1	1	PCS
R155	61L0603472	CHIPR 4.7K OHM +-5% 1/1	1	PCS
R161	61L0603472	CHIPR 4.7K OHM +-5% 1/1	1	PCS
R162	61L0603472	CHIPR 4.7K OHM +-5% 1/1	1	PCS
R163	61L0603472	CHIPR 4.7K OHM +-5% 1/1	1	PCS
R168	61L0603472	CHIPR 4.7K OHM +-5% 1/1	1	PCS
R117	61L0603473	CHIP 47K OHM 1/10W	1	PCS
R118	61L0603473	CHIP 47K OHM 1/10W	1	PCS
R156	61L0603473	CHIP 47K OHM 1/10W	1	PCS
R106	61L0603750 9F	750HM 1% 1/10W	1	PCS
R107	61L0603750 9F	750HM 1% 1/10W	1	PCS
R108	61L0603750 9F	750HM 1% 1/10W	1	PCS
R172	61L1206331	CHIP 3300HM 5% 1/4W	1	PCS
C147	65L0603100 31	CHIP 10PF+-0.5PF 50V NP	1	PCS
C148	65L0603100 31	CHIP 10PF+-0.5PF 50V NP	1	PCS
C152	65L0603102 32	1000PF +-10% 50V X7R	1	PCS
C153	65L0603102 32	1000PF +-10% 50V X7R	1	PCS
C154	65L0603102 32	1000PF +-10% 50V X7R	1	PCS
C155	65L0603102 32	1000PF +-10% 50V X7R	1	PCS
C156	65L0603102 32	1000PF +-10% 50V X7R	1	PCS
C157	65L0603102 32	1000PF +-10% 50V X7R	1	PCS
C119	65L0603104 12	0.1UF +-10% 16V X7R	1	PCS
C123	65L0603104 12	0.1UF +-10% 16V X7R	1	PCS
C124	65L0603104 12	0.1UF +-10% 16V X7R	1	PCS
C125	65L0603104 12	0.1UF +-10% 16V X7R	1	PCS
C126	65L0603104 12	0.1UF +-10% 16V X7R	1	PCS
C127	65L0603104 12	0.1UF +-10% 16V X7R	1	PCS
C128	65L0603104 12	0.1UF +-10% 16V X7R	1	PCS
C130	65L0603104 12	0.1UF +-10% 16V X7R	1	PCS
C131	65L0603104 12	0.1UF +-10% 16V X7R	1	PCS

C132	65L0603104 12	0.1UF +-10% 16V X7R	1	PCS
C133	65L0603104 12	0.1UF +-10% 16V X7R	1	PCS
C134	65L0603104 12	0.1UF +-10% 16V X7R	1	PCS
C135	65L0603104 12	0.1UF +-10% 16V X7R	1	PCS
C137	65L0603104 12	0.1UF +-10% 16V X7R	1	PCS
C138	65L0603104 12	0.1UF +-10% 16V X7R	1	PCS
C139	65L0603104 12	0.1UF +-10% 16V X7R	1	PCS
C141	65L0603104 12	0.1UF +-10% 16V X7R	1	PCS
C142	65L0603104 12	0.1UF +-10% 16V X7R	1	PCS
C144	65L0603104 12	0.1UF +-10% 16V X7R	1	PCS
C145	65L0603104 12	0.1UF +-10% 16V X7R	1	PCS
C149	65L0603104 12	0.1UF +-10% 16V X7R	1	PCS
C150	65L0603104 12	0.1UF +-10% 16V X7R	1	PCS
C159	65L0603104 12	0.1UF +-10% 16V X7R	1	PCS
C163	65L0603104 12	0.1UF +-10% 16V X7R	1	PCS
C164	65L0603104 12	0.1UF +-10% 16V X7R	1	PCS
C167	65L0603104 12	0.1UF +-10% 16V X7R	1	PCS
C168	65L0603104 12	0.1UF +-10% 16V X7R	1	PCS
C173	65L0603104 12	0.1UF +-10% 16V X7R	1	PCS
C174	65L0603104 12	0.1UF +-10% 16V X7R	1	PCS
C175	65L0603104 12	0.1UF +-10% 16V X7R	1	PCS
C104	65L0603473 32	CHIP 0.047UF 50V X7R	1	PCS
C106	65L0603473 32	CHIP 0.047UF 50V X7R	1	PCS
C108	65L0603473 32	CHIP 0.047UF 50V X7R	1	PCS
C112	65L0603473 32	CHIP 0.047UF 50V X7R	1	PCS
C113	65L0603473 32	CHIP 0.047UF 50V X7R	1	PCS
C114	65L0603473 32	CHIP 0.047UF 50V X7R	1	PCS
FB105	71L 56K121	CHIP BEAD 120OHM 6A	1	PCS
L101	71L 56K121	CHIP BEAD 120OHM 6A	1	PCS
L102	71L 56K121	CHIP BEAD 120OHM 6A	1	PCS
L103	71L 56K121	CHIP BEAD 120OHM 6A	1	PCS
L104	71L 56K121	CHIP BEAD 120OHM 6A	1	PCS
L105	71L 56K121	CHIP BEAD 120OHM 6A	1	PCS
L106	71L 56K121	CHIP BEAD 120OHM 6A	1	PCS
R101	71L 59Q101	CHIP BEAD 100 OHM	1	PCS
R104	71L 59Q101	CHIP BEAD 100 OHM	1	PCS
R105	71L 59Q101	CHIP BEAD 100 OHM	1	PCS
U101	87L 202 44	PLCC SMT CONN PD41C-441	1	PCS
D102	93L 39146	LL5232B SMT	0	PCS
D103	93L 39146	LL5232B SMT	0	PCS

D104	93L 39146	LL5232B SMT	0	PCS
D107	93L 39146	LL5232B SMT	0	PCS
D108	93L 39146	LL5232B SMT	0	PCS
D109	93L 39146	LL5232B SMT	0	PCS
D111	93L 39146	LL5232B SMT	0	PCS
D112	93L 39146	LL5232B SMT	0	PCS
D102	93L 39149	MLL5232B BY FULL POWER	1	PCS
D103	93L 39149	MLL5232B BY FULL POWER	1	PCS
D104	93L 39149	MLL5232B BY FULL POWER	1	PCS
D107	93L 39149	MLL5232B BY FULL POWER	1	PCS
D108	93L 39149	MLL5232B BY FULL POWER	1	PCS
D109	93L 39149	MLL5232B BY FULL POWER	1	PCS
D111	93L 39149	MLL5232B BY FULL POWER	1	PCS
D112	93L 39149	MLL5232B BY FULL POWER	1	PCS
D110	93L 60230	BAT54C(L43)	1	PCS
D101	93L 64 33	BAV99	0	PCS
D105	93L 64 33	BAV99	0	PCS
D106	93L 64 33	BAV99	0	PCS
D101	93L 6433P	BAV99	1	PCS
D105	93L 6433P	BAV99	1	PCS
D106	93L 6433P	BAV99	1	PCS
	715L1280 D	DELL MAIN BOARD	1	PCS
-----	-----	-----	-----	-----
PARENT NO:	KEPC780KED1	KEY BOARD		
-----	-----	-----	-----	-----
R101	61L 60210152T	1000HM +- 5% 1/6W	1	PCS
SW101	77L 600 4 HJ	TACT SWITCH TSPE-1	1	PCS
SW102	77L 600 4 HJ	TACT SWITCH TSPE-1	1	PCS
SW103	77L 600 4 HJ	TACT SWITCH TSPE-1	1	PCS
SW104	77L 600 4 HJ	TACT SWITCH TSPE-1	1	PCS
DP101	81L 12 1A GP	LED	1	PCS
CN101	95L8014 8 10	WURE HARNESS	1	PCS
	715L1153 1A	PCB	1	PCS
-----	-----	-----	-----	-----
PARENT NO:	PWPC1742LGD1	POWER BOARD		
-----	-----	-----	-----	-----
	PW1742LGD1AI	POWER BOARD	1	PCS
	PW1742LGD1SMT	POWER BOARD	1	PCS
CON201	33L8021 2D E	WAFER	0	PCS
CON202	33L8021 2D E	WAFER	0	PCS



CON203	33L8021 2D E	WAFER	0	PCS
CON204	33L8021 2D E	WAFER	0	PCS
CON201	33L8021 2D AC	CONN. 2P R/A 87210-0236	1	PCS
CON202	33L8021 2D AC	CONN. 2P R/A 87210-0236	1	PCS
CON203	33L8021 2D AC	CONN. 2P R/A 87210-0236	1	PCS
CON204	33L8021 2D AC	CONN. 2P R/A 87210-0236	1	PCS
CN901	33L8029 4A	PLUG	1	PCS
	40L 45762420A	ID LABEL	1	PCS
IC902	56L 139 3B	PC123 Y82	1	PCS
IC901	56L 379 32	SG6841D BY SYSTEM	1	PCS
Q209	57L 761 6	2SC5706 DIP SANYO	1	PCS
Q210	57L 761 6	2SC5706 DIP SANYO	1	PCS
Q211	57L 761 6	2SC5706 DIP SANYO	1	PCS
Q212	57L 761 6	2SC5706 DIP SANYO	1	PCS
NR901	61L 58120 WT	NTCR 120HM 20% 2A SCK-1	1	PCS
C903	63L 107474 5S	0.47UF +-10% 250VAC	0	PCS
C903	63L 107474 FS	0.47UF +-10% 250VAC	0	PCS
C903	63L 107474 HS	0.47UF +-10% 250VAC	0	PCS
C903	63L 10747410S	0.47UF +-10% 250VAC	1	PCS
C213	63L210J1842A2	PMS 0.18UF 250V	1	PCS
C214	63L210J1842A2	PMS 0.18UF 250V	1	PCS
C213	64L180J184AAT	CAP 0.18UF 160V R79	0	PCS
C214	64L180J184AAT	CAP 0.18UF 160V R79	0	PCS
C226	65L 3J2206EM	22PF 5% 3KV MURATA	0	PCS
C227	65L 3J2206EM	22PF 5% 3KV MURATA	0	PCS
C228	65L 3J2206EM	22PF 5% 3KV MURATA	0	PCS
C229	65L 3J2206EM	22PF 5% 3KV MURATA	0	PCS
C226	65L 3J2206ET	22PF 5% 3KV TDK	1	PCS
C227	65L 3J2206ET	22PF 5% 3KV TDK	1	PCS
C228	65L 3J2206ET	22PF 5% 3KV TDK	1	PCS
C229	65L 3J2206ET	22PF 5% 3KV TDK	1	PCS
C901	65L305M1022B2	1000PF 400VAC/250VAC	0	PCS
C902	65L305M1022B2	1000PF 400VAC/250VAC	0	PCS
C901	65L305M1022EM	1000PF +-20% 250VAC/400	1	PCS
C902	65L305M1022EM	1000PF +-20% 250VAC/400	1	PCS
C913	65L306M3322F2	3300PF +-20% 400VAC Y1	1	PCS
C912	65L306M4722B2	4700PF +-20% 400VAC Y1	1	PCS
C922	67L215C102 3H	EC LESR 1000UF16V HERME	1	PCS
C923	67L215C102 3H	EC LESR 1000UF16V HERME	1	PCS
C922	67L215C102 3K	1000UF/16V	0	PCS

C923	67L215C102 3K	1000UF/16V	0	PCS
C904	67L215S10115H	100UF 450V 18*36 105 BY	0	PCS
C904	67L215S10115K	100UF 450V	0	PCS
C904	67L215S10115N	100UF+-20% 450V	1	PCS
C922	67L215S102 3N	EC 105 16V 1000UF KZE16	0	PCS
C923	67L215S102 3N	EC 105 16V 1000UF KZE16	0	PCS
	71L 55 2	A FERRITE BEAD 6.5*5*1.7	1	PCS
L902	73L 174 26 LS	COMMON CHOKE	0	PCS
L902	73L 174 26 T1	LINE LILTER 0.45mm	1	PCS
L203	73L 174 30 H	FILTER 500MH HA	0	PCS
L204	73L 174 30 H	FILTER 500MH HA	0	PCS
L203	73L 174 30 LS	FILTER	0	PCS
L204	73L 174 30 LS	FILTER	0	PCS
L203	73L 174 30 YS	FILTER	1	PCS
L204	73L 174 30 YS	FILTER	1	PCS
L903	73L 253 91 L	CHOKE BY LI TA	0	PCS
L904	73L 253 91 L	CHOKE BY LI TA	0	PCS
L903	73L 253 91 LS	CHOKE BY LI SHIN	1	PCS
L904	73L 253 91 LS	CHOKE BY LI SHIN	1	PCS
L201	73L 253139 YL	CHOKE	1	PCS
L202	73L 253139 YL	CHOKE	1	PCS
PT201	80LL15T 7 DN	X' FMR	0	PCS
PT202	80LL15T 7 DN	X' FMR	0	PCS
PT201	80LL15T 7 YS	X' FMR	1	PCS
PT202	80LL15T 7 YS	X' FMR	1	PCS
T901	80LL17T 2 T	X' FMR	1	PCS
T901	80LL17T 2 LS	ADAPTOR BY LISHIN	0	PCS
BD901	93L 50460 8	BRIDGE 2KBP06M2A600V	1	PCS
CON102	95L8014 6 19	PIN HEADER	1	PCS
	705L 560 57 DL	D910/D911 ASS' Y	1	PCS
	705L 560 61 05	R917 ASS' Y	1	PCS
	705L 560 61 06	R903 ASS' Y	1	PCS
	705L 780 57 DL	Q903 ASS' Y	1	PCS
-----	-----	-----	-----	-----
PARENT NO:	PW1742LGD1AI	POWER BOARD		
-----	-----	-----	-----	-----
CN901	6L 31500	EYELET	2	PCS
C213	6L 31502	1.5MM RIVET	2	PCS
C214	6L 31502	1.5MM RIVET	2	PCS
C904	6L 31502	1.5MM RIVET	2	PCS

L902	6L 31502	1.5MM RIVET	4	PCS
PT201	6L 31502	1.5MM RIVET	2	PCS
PT202	6L 31502	1.5MM RIVET	2	PCS
T901	6L 31502	1.5MM RIVET	4	PCS
	715L1283 2	POWER BOARD	1	PCS
J001	95L 90 23	TIN COATED	0	PCS
J002	95L 90 23	TIN COATED	0	PCS
J003	95L 90 23	TIN COATED	0	PCS
J004	95L 90 23	TIN COATED	0	PCS
J005	95L 90 23	TIN COATED	0	PCS
J006	95L 90 23	TIN COATED	0	PCS
J007	95L 90 23	TIN COATED	0	PCS
J008	95L 90 23	TIN COATED	0	PCS
J009	95L 90 23	TIN COATED	0	PCS
J010	95L 90 23	TIN COATED	0	PCS
J011	95L 90 23	TIN COATED	0	PCS
J012	95L 90 23	TIN COATED	0	PCS
J014	95L 90 23	TIN COATED	0	PCS
J015	95L 90 23	TIN COATED	0	PCS
J016	95L 90 23	TIN COATED	0	PCS
J017	95L 90 23	TIN COATED	0	PCS
J018	95L 90 23	TIN COATED	0	PCS
J020	95L 90 23	TIN COATED	0	PCS
J021	95L 90 23	TIN COATED	0	PCS
L205	95L 90 23	TIN COATED	0	PCS
L206	95L 90 23	TIN COATED	0	PCS
R927	95L 90 23	TIN COATED	1	PCS
R915	61L 17210052T	100HM 5% 1/4W	1	PCS
R929	61L 17210152T	100 OHM 5% 1/4W	1	PCS
R224	61L 17210252T	1K OHM 5% 1/4W	1	PCS
R225	61L 17210252T	1K OHM 5% 1/4W	1	PCS
R226	61L 17210252T	1K OHM 5% 1/4W	1	PCS
R227	61L 17210252T	1K OHM 5% 1/4W	1	PCS
R228	61L 17210252T	1K OHM 5% 1/4W	1	PCS
R229	61L 17210252T	1K OHM 5% 1/4W	1	PCS
R230	61L 17210252T	1K OHM 5% 1/4W	1	PCS
R231	61L 17210252T	1K OHM 5% 1/4W	1	PCS
R232	61L 17210252T	1K OHM 5% 1/4W	1	PCS
R233	61L 17210252T	1K OHM 5% 1/4W	1	PCS
R925	61L 17210252T	1K OHM 5% 1/4W	1	PCS

R926	61L 17210252T	1K OHM 5% 1/4W	1	PCS
R916	61L 17210352T	CFR 10KOHM +-5% 1/4W	1	PCS
R924	61L 20024252T	2. 4KOHM 1% 1/4W	1	PCS
R922	61L 20033352T	33KOHM 1% 1/4W	1	PCS
R923	61L 20036252T	3. 6KOHM 1% 1/4W	1	PCS
R201	61L 60224352T	24K OHM 5% 1/6W	1	PCS
R920	61L175L47052T	47OHM +-5% 1/2W	1	PCS
R921	61L175L47052T	47OHM +-5% 1/2W	1	PCS
R904	61L214Y10552T	1M, 1/4W	1	PCS
R905	61L214Y10552T	1M, 1/4W	1	PCS
R906	61L214Y10552T	1M, 1/4W	1	PCS
R907	61L214Y10552T	1M, 1/4W	1	PCS
FB901	71L 55 29	FERRITE BEAD	1	PCS
ZD902	93L 39 5452T	ZENER HZ12B2	1	PCS
ZD903	93L 39 7752T	ZENER HZ5C1	1	PCS
D901	93L 6026T52T	RECTIFIER DIODE FR107	1	PCS
D902	93L 6038P52T	PS102R	1	PCS
D205	93L 64 1152T	1N4148	1	PCS
D206	93L 64 1152T	1N4148	1	PCS
D207	93L 64 1152T	1N4148	1	PCS
D208	93L 64 1152T	1N4148	1	PCS
D209	93L 64 1152T	1N4148	1	PCS
D210	93L 64 1152T	1N4148	1	PCS
D903	93L 64 1152T	1N4148	1	PCS
IC903	56L 158 4 T	A HTL431	1	PCS
Q902	57L 419 PP T	2PC945P	1	PCS
Q901	57L 420 PP T	2PA733P	1	PCS
C929	64L700J1040AT	0. 1UF 50V PEN	1	PCS
C905	65L 2K152 1T6052	1. 5NF/2KV Y5P +-10%	0	PCS
C905	65L 2K152 1T6285	1. 5NF/2KV Y5P +-10%	0	PCS
C905	65L 2K152 1T6921	1. 5NF/2KV Y5P +-10%	1	PCS
C920	65L517K102 5T	1000PF 10% Y5P 500V	1	PCS
C921	65L517K102 5T	1000PF 10% Y5P 500V	1	PCS
C906	67L 305220 7T	22UF +-20% 50V	1	PCS
C207	67L 305330 7T	33UF 105	1	PCS
C924	67L215B4713HT	470UF 16V LTR471M1CF11V	1	PCS
C925	67L215B4713HT	470UF 16V LTR471M1CF11V	1	PCS
C924	67L215B4713KT	LOW ESR 470UF16V BY HER	0	PCS
C925	67L215B4713KT	LOW ESR 470UF16V BY HER	0	PCS
C201	67L215C1514HT	LOW ESR 150UF 25V 8*7MM	1	PCS

C223	67L215C1514HT	LOW ESR 150UF 25V 8*7MM	1	PCS
C924	67L215N4713NT	EC 105 16V 470UF KZE16V	0	PCS
C925	67L215N4713NT	EC 105 16V 470UF KZE16V	0	PCS
F901	84L 56 1	FUSE 2A 250V WICKMANN	1	PCS
-----	-----	-----	-----	-----
PARENT NO:	PW1742LGD1SMT	POWER BOARD		
-----	-----	-----	-----	-----
U201	56L 608 1	TL1451ACD	1	PCS
U201	56L 622 1	BA9741F-SMT	0	PCS
Q205	57L 417 4	PMBS3904/PHILIPS-SMT(04	1	PCS
Q206	57L 417 4	PMBS3904/PHILIPS-SMT(04	1	PCS
Q207	57L 417 6	PMBS3906/PHILIPS-SMT(06	1	PCS
Q208	57L 417 6	PMBS3906/PHILIPS-SMT(06	1	PCS
Q203	57L 600 37	STS6PF30L SO-8	0	PCS
Q204	57L 600 37	STS6PF30L SO-8	0	PCS
Q202	57L 760 4	DTA144WKA BY ROHM SMT(7	1	PCS
Q201	57L 760 5	DTC144WKA BY ROHM SMT(8	1	PCS
Q203	57L 763 3	A04411 SO-8 BY AOS SMT	0	PCS
Q204	57L 763 3	A04411 SO-8 BY AOS SMT	0	PCS
Q203	57L 763 4	RSS050P03	1	PCS
Q204	57L 763 4	RSS050P03	1	PCS
R204	61L0603103	CHIPR 10K OHM +-5% 1/10	1	PCS
R210	61L0603123	CHIP 12K OHM 1/10W	1	PCS
R211	61L0603123	CHIP 12K OHM 1/10W	1	PCS
R220	61L0603123	CHIP 12K OHM 1/10W	1	PCS
R221	61L0603123	CHIP 12K OHM 1/10W	1	PCS
R238	61L0603123	CHIP 12K OHM 1/10W	1	PCS
R239	61L0603123	CHIP 12K OHM 1/10W	1	PCS
R222	61L0603153	CHIPR 15KOHM+-5% 1/10W	1	PCS
R223	61L0603153	CHIPR 15KOHM+-5% 1/10W	1	PCS
R216	61L0603221	CHIPR 220 OHM+-5% 1/10W	1	PCS
R217	61L0603221	CHIPR 220 OHM+-5% 1/10W	1	PCS
R212	61L0603392	CHIP 3.9K OHM 1/10W	1	PCS
R213	61L0603392	CHIP 3.9K OHM 1/10W	1	PCS
R214	61L0603392	CHIP 3.9K OHM 1/10W	1	PCS
R215	61L0603392	CHIP 3.9K OHM 1/10W	1	PCS
R218	61L0603471	CHIPR 470 OHM+-5% 1/10W	1	PCS
R219	61L0603471	CHIPR 470 OHM+-5% 1/10W	1	PCS
R208	61L0603472	CHIPR 4.7K OHM +-5% 1/1	1	PCS
R209	61L0603472	CHIPR 4.7K OHM +-5% 1/1	1	PCS

R236	61L0603511	CHIPR 510 OHM+-5% 1/10W	1	PCS
R237	61L0603511	CHIPR 510 OHM+-5% 1/10W	1	PCS
R202	61L0603512	CHIP 5.1K OHM 1/10W	1	PCS
R203	61L0603512	CHIP 5.1K OHM 1/10W	1	PCS
R240	61L0603513	CHIP 51K OHM 1/10W	1	PCS
R241	61L0603513	CHIP 51K OHM 1/10W	1	PCS
R234	61L0603621	CHIPR 620 OHM+-5% 1/10W	1	PCS
R235	61L0603621	CHIPR 620 OHM+-5% 1/10W	1	PCS
R205	61L0603683	CHIP 68K OHM 1/10W	1	PCS
R206	61L0603683	CHIP 68K OHM 1/10W	1	PCS
F201	61L1206000	CHIPR 0 OHM +-5% 1/4W	1	PCS
R912	61L1206101	CHIP 100 OHM 5% 1/4W	1	PCS
R928	61L1206102	CHIP 1K OHM 5% 1/4W	1	PCS
R913	61L1206103	CHIP 10KOHM 5% 1/4W	1	PCS
R901	61L1206105	CHIP 1MOHM 5% 1/4W	1	PCS
R902	61L1206105	CHIP 1MOHM 5% 1/4W	1	PCS
R914	61L1206243	CHIP 24K OHM 5% 1/4W	1	PCS
R909	61L1206472	CHIP 4.7KOHM 5% 1/4W	1	PCS
R910	61L1206472	CHIP 4.7KOHM 5% 1/4W	1	PCS
R911	61L1206472	CHIP 4.7KOHM 5% 1/4W	1	PCS
R908	61L1206519	CHIPR 510OHM +-5% 1/4W	1	PCS
C230	65L0805102 32	CHIP 1000P 50VX7R 0805	1	PCS
C231	65L0805102 32	CHIP 1000P 50VX7R 0805	1	PCS
C910	65L0805102 32	CHIP 1000P 50VX7R 0805	1	PCS
C930	65L0805102 32	CHIP 1000P 50VX7R 0805	1	PCS
C931	65L0805102 32	CHIP 1000P 50VX7R 0805	1	PCS
C202	65L0805104 22	0.1UF +-10% 25V X7R 080	1	PCS
C204	65L0805104 22	0.1UF +-10% 25V X7R 080	1	PCS
C205	65L0805104 22	0.1UF +-10% 25V X7R 080	1	PCS
C206	65L0805104 22	0.1UF +-10% 25V X7R 080	1	PCS
C907	65L0805104 32	CHIP 0.1UF 50V X7R	1	PCS
C908	65L0805104 32	CHIP 0.1UF 50V X7R	1	PCS
C909	65L0805104 32	CHIP 0.1UF 50V X7R	1	PCS
C926	65L0805104 32	CHIP 0.1UF 50V X7R	1	PCS
C927	65L0805104 32	CHIP 0.1UF 50V X7R	1	PCS
C203	65L0805105 22	CHIP 1UF 25V X7R 0805	1	PCS
C209	65L0805105 22	CHIP 1UF 25V X7R 0805	1	PCS
C210	65L0805105 22	CHIP 1UF 25V X7R 0805	1	PCS
C211	65L0805105 22	CHIP 1UF 25V X7R 0805	1	PCS
C212	65L0805105 22	CHIP 1UF 25V X7R 0805	1	PCS

C219	65L0805105 22	CHIP 1UF 25V X7R 0805	1	PCS
C220	65L0805105 22	CHIP 1UF 25V X7R 0805	1	PCS
C208	65L0805331 32	CHIP 330PF 50V X7R 0805	1	PCS
C221	65L0805474 22	CHIP 0.47UF 25V X7R 080	1	PCS
C222	65L0805474 22	CHIP 0.47UF 25V X7R 080	1	PCS
D203	93L 39S 3 T	BZT52-C11	0	PCS
D204	93L 39S 3 T	BZT52-C11	0	PCS
D203	93L 39S 8 T	ZD RLZ11B ROHM	1	PCS
D204	93L 39S 8 T	ZD RLZ11B ROHM	1	PCS
ZD901	93L 39S 12 T	RLZ20B BY ROHM	1	PCS
ZD904	93L 39S 16 T	SML4737A/1	0	PCS
ZD904	93L 39S 19 T	PTZ7.5B	1	PCS
D201	93L2004 2A	SM240A	0	PCS
D202	93L2004 2A	SM240A	0	PCS
D201	93L3004 1	SMAL340XXXRO 3A 40V SMA	0	PCS
D202	93L3004 1	SMAL340XXXRO 3A 40V SMA	0	PCS
D201	93L3004 2	SR34 PAN JIT	1	PCS
D202	93L3004 2	SR34 PAN JIT	1	PCS
-----	-----	-----	-----	-----
PARENT NO:	705L 560 57 DL	D910/D911 ASS'Y		
-----	-----	-----	-----	-----
	90L6064 1	HEAT SINK	1	PCS
D911	93L 60235	FCQ10A06 (F10P06Q)	1	PCS
D911	93L 60236	FMB-26L	0	PCS
D910	93L 60238	FCH10A15 T0-220	1	PCS
D910	93L 60239	FME-210B T0-220	0	PCS
	M1L1730 8128	SCREW M3x8	2	PCS
-----	-----	-----	-----	-----
PARENT NO:	705L 560 61 05	R917 ASS'Y		
-----	-----	-----	-----	-----
R917	61L 2J39858H	0.3900HM 5% 2W	1	PCS
	96L 29 6	SHRINK TUBE UL/CSA	1	PCS
-----	-----	-----	-----	-----
PARENT NO:	705L 560 61 06	R903 ASS'Y		
-----	-----	-----	-----	-----
R903	61L152M10458F	100K OHM 5% 2W	1	PCS
	96L 29 6	SHRINK TUBE UL/CSA	1	PCS
-----	-----	-----	-----	-----
PARENT NO:	705L 780 57 DL	Q903 ASS'Y		
-----	-----	-----	-----	-----

Q903	57L 600 35	STP8NK80ZFP	0	PCS
Q903	57L 667 15	FQPF7N80 TO-220F	1	PCS
	90L6064 1	HEAT SINK	1	PCS
	M1L1730 8128	SCREW M3x8	1	PCS
-----	-----	-----	-----	-----
PARENT NO:	705L 780 87 DL	CN901 ASS' Y		
-----	-----	-----	-----	-----
	87L 501 14 RF	AC SOCKET	1	PCS
	95L 900 42	HARNESS	1	PCS
	95L8021 2508	WIRE HARNESS	1	PCS
	96L 29 6	SHRINK TUBE UL/CSA	3	PCS
-----	-----	-----	-----	-----
PARENT NO:	705L780KB34 79	BACK COVER ASS' Y		
-----	-----	-----	-----	-----
	12L 394 5	FOOT PORON	0	PCS
	15L8053 1	BRACKET BASE	1	PCS
	20L 015 1	RISER DIECASTING	1	PCS
	34L1369 Y2 T	VESA COVER	1	PCS
	34L1370 Y2 T	STAND FRANT	1	PCS
	34L1371 Y2 T	STAND BACK	1	PCS
	34L1372 Y2 T	BASE	1	PCS
	37L 483 2	HINGE	1	PCS
	M1L 130 8225	SCREW	3	PCS
	M1L 140 8 47	SRCEW	4	PCS
	Q1L 330 8 47	SCREW 3X8mm	4	PCS
	Q1L 330 8 47	SCREW 3X8mm	2	PCS