



M a n u e l  
d ' u t i l i s a t i o n .  
M a n u a l d e  
u t i l i z a c i ó n .  
U s e r  
m a n u a l .  
M a n u e l  
d ' u t i l i s a t i o n .  
M a n u a l d e  
u t i l i z a c i ó n .  
U s e r  
m a n u a l .  
7 2 M K 8 9 D

---

**THOMSON**

# television set safety precautions



## SAFE USE OF THE EQUIPMENT

### 1. TO TURN ON

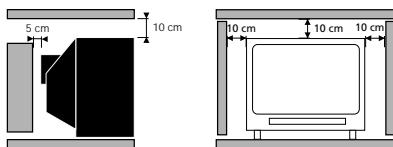

#### LEAVE ROOM FOR VENTILATION

To ensure your personal safety and the efficient operation of your equipment, please follow the advice given below :  
Télévision sets need ventilation to avoid overheating which can cause damage to the components. The ventilation slots at the back of the set should not be covered up by curtains, small covers, newspapers, etc... There must be enough room in built-in cabinets to allow for the cooling air to circulate. The set should not be placed directly next to heating.

This appliance is designed for use in dry areas. If occasionally you should wish to operate it outdoors (for example, on the balcony or veranda), you must insure that it is protected against all forms of moisture (dew, rain, splashed water).

A cold set may be switched on in a warm room only after any condensation which may happen to be on the screen has evaporated. Never remove the cabinet back. Have your aerial installed by an authorised dealer or service technician.

In the evenings, after the TV programmes, or in case of a prolonged absence, it is recommended that the appliance be switched off using the main power switch. Remove the power plug from the wall outlet under the following conditions :

1. During a thunderstorm. It is also recommended that you disconnect the aerial plug.
2. If you find a burning smell or smoke emerging from the set.

Additional information :

Your TV set is adequately shielded to prevent emission of X-rays. The acceleration voltage does not exceed the maximum value of 33 kV.

Work by non-qualified technicians, modification of the high voltage setting or the replacement of the tube with a model that does not comply with the manufacturer's specifications may lead to a considerable increase in X-ray radiation.

A set changed in any of the above ways no longer satisfies the initial specifications and should not be put back into service.

#### AVOID HEAT, WATER, DIRECT SUNLIGHT.

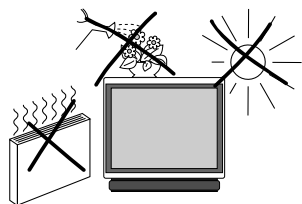

**Do not place audio loudspeakers near to television. The magnets in the speakers could cause patches of colour to appear on the screen.**

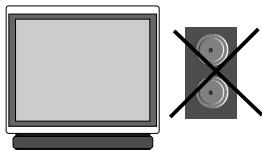

### 2. CARE OF THE EQUIPMENT

The screen should be cleaned with liquid glass cleaner.

- Never use abrasive cleaners.
- To clean the front and the cabinet of your equipment use a soft cloth dipped in mild detergent. The use of strong solvents such as white spirits or alcohol based products could damage your equipment.
- Clean the vents on the rear panel of your set regularly.

### 3. DEMAGNETISATION

The earth's magnetic field may have an effect on your television by causing patches of colour to appear on the screen. If this happens :

- Switch off the television with the on-off button ;
- Wait a few minutes and then press again to switch on.

This allows the screen to be demagnetised automatically. If patches of colour are still visible repeat the procedure.



The pages of this publication are printed on recycled paper.

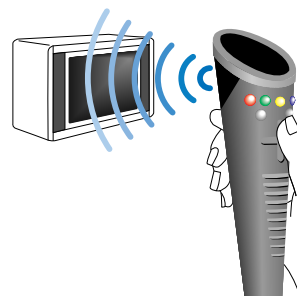
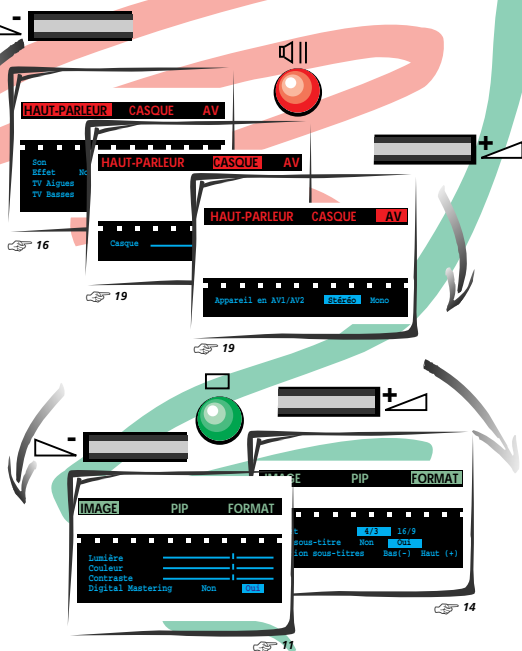
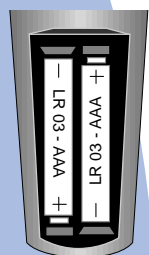
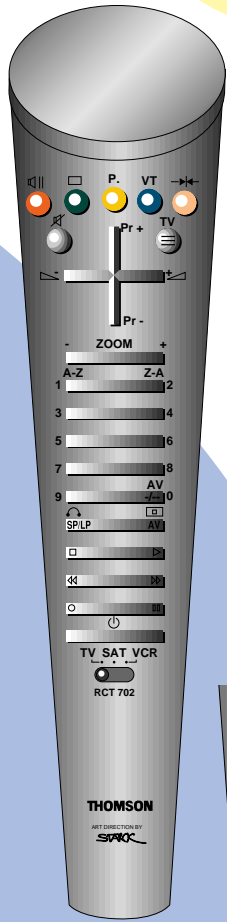
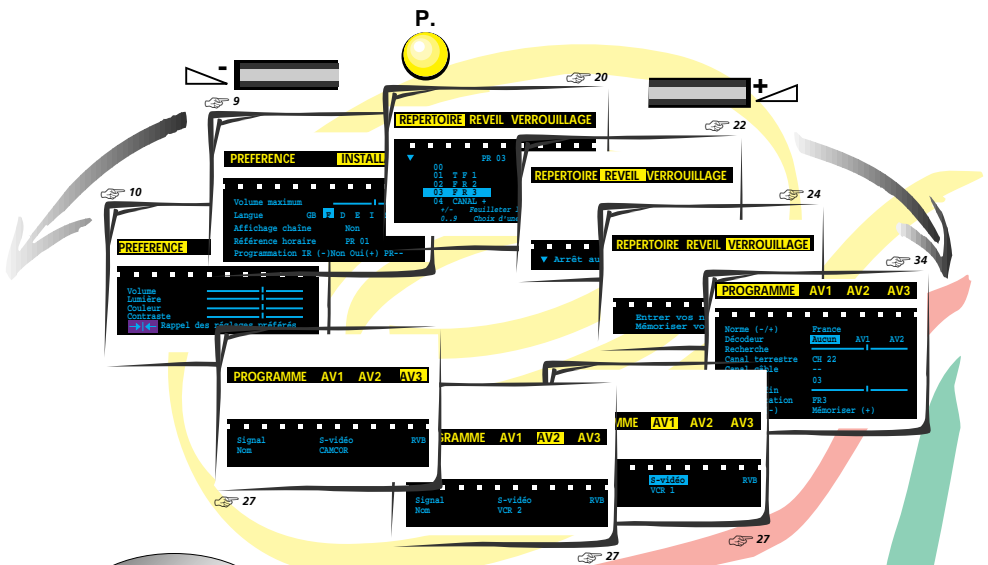

Vertical sidebar icons:

- P.
- AV
- ZOOM
- SP/LP
- Navigation arrows (Pr+, Pr-, etc.)
- A-Z, Z-A
- 1-9
- AV
- TV
- Power button

# remote control functions

# using remote control

P.



## PROGRAMME

Set-up - Preferences -  
Browse - Clock - Lock -  
Tuning - AV1 - AV2 - AV3.



## SOUND

Speaker Configuration - Balance - Loudspeakers -  
Headphone - AV (Audiovisual).



## PICTURE

Picture - PIP - Format.



## TELETEXT / TOPTTEXT / FASTTEXT



## PERSONAL ADJUSTMENTS

and scrolling back through the menus.



## TO REMOVE THE MENU DISPLAY

or to display programme information, the type of sound transmission (MONO, STEREO or DUAL), the programme name and number, the time.



## PICTURE FREEZE

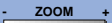

## ZOOM FUNCTION



## TO CALL UP PREVIOUSLY VIEWED PROGRAMME



## TO CALL UP ALL PROGRAMMES IN TURN



## VOLUME

- Horizontal movement in the menus  
- +/- adjustments of other functions.

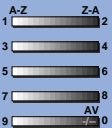

Keys 1 to 0 are used to :

- Select the programmes (from 1 to 99)
- Enter the channels numbers
- The 0 key is used to call AV inputs 1, 2 and 3.



## MUTE

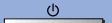

## STAND-BY

**!** To operate your television set by remote control, the selector switch TV-SAT-VCR must be on TV position

When a red, green or yellow button is pressed for the first time, the **contents** of the menu are displayed at the top of the screen and the menu of the function selected is displayed at the bottom of the screen.

Moving horizontally along in the menus selects the required function on the contents line if it has not been already selected.

- **The selected function** is displayed in the same colour as the button pressed (red, green, yellow).

Press the coloured button repeatedly to move down through the menus selecting different lines.

- **The line selected** in the menus is displayed in the same colour as the button pressed (red, green, yellow).

Make any adjustments.

Changes are saved when you quit the menus, except in the PROGRAMME menu.

## contents

### CONNECTIONS AND COMMANDS 5/6

#### AUTO-PROGRAMMING 7/9

Switching on - Automatic stations search  
Programme organiser - New region

#### INSTALLATION 9/10

Volume limitation - Menu language -  
Programme number display - Time reference - Preferred settings.

#### PICTURE ADJUSTMENTS 11/14

PIP - Format

#### SOUND ADJUSTMENTS 14/19

Pro Logic - Loudspeakers - Balance  
Headphone - AV

#### DAY TO DAY OPERATION 20/21

Switching on/Selecting programmes - Browse

#### OTHER FUNCTIONS - EXTRAS 22/25

Clock - Child lock - Lock

#### CONNECTIONS 26/30

Units connected - Calling up audiovisual programmes -

#### TELETEXT 31/33

Calling up Teletext - Options - Alarm - How to select - Subtitles - New flash

#### MANUAL PROGRAMMING 34/35

Norm - Decoder - Channel/Cable - Programme - Fine Tuning - Station name - Store/Erase - Access to the organiser.

BATTERIES : Refer to page 30 for the fitting of the batteries

# television set

## connections and commands

For further details, see page 26.



### FRONT AND RIGHT SIDE

Connect to A.C. main supply  
220-240 V ~ 50 Hz

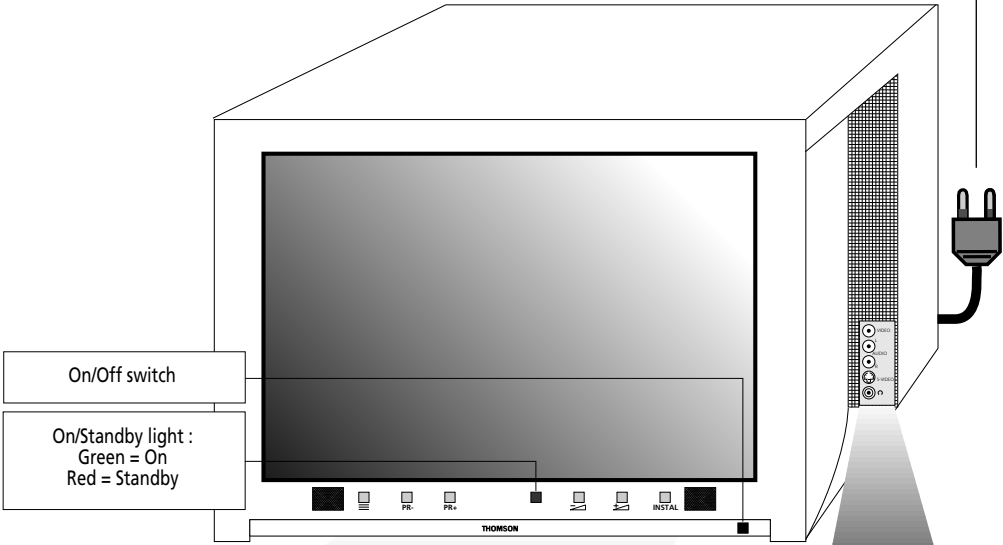

On/Off switch

On/Standby light :  
Green = On  
Red = Standby

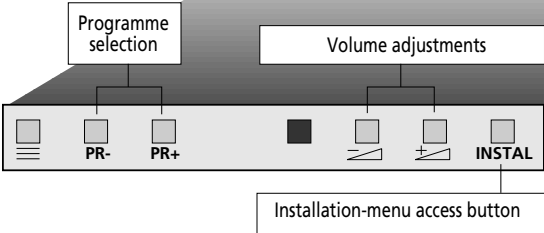

VIDEO and AUDIO Sockets

S-VIDEO and AUDIO Sockets

Headphone socket  
Ø 6,35 mm

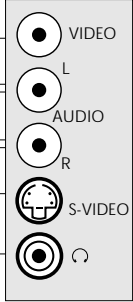

AV 3

# television set

## connections and commands



### BACK CONNECTIONS

### Ideal setting

Connect respectively the red and black terminals of the supplied speakers to the television's red and black terminals.

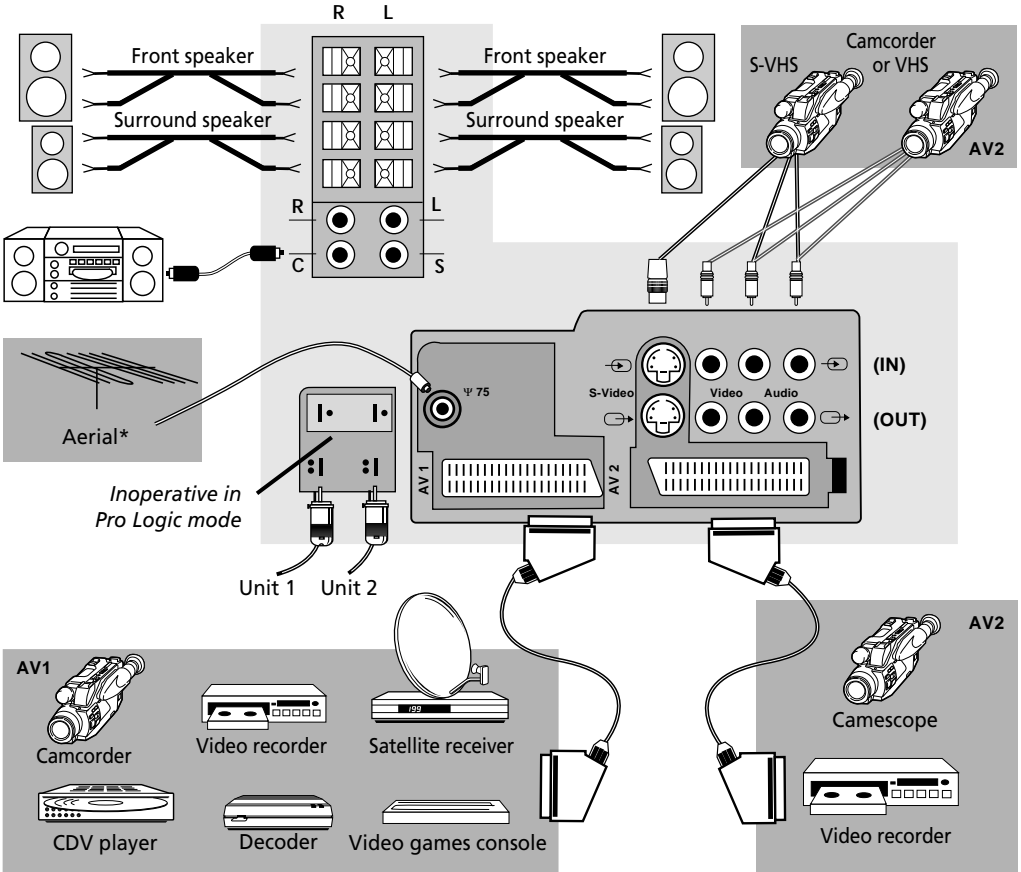
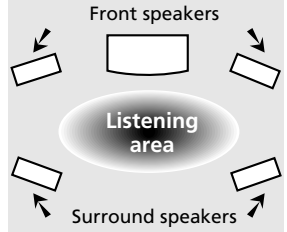

! \* We recommend that you use an aerial cable with double isolation.

# television set auto-programming



This set is equipped with an automatic station search system which is used for :

- Searching for all the stations received in your region and storing them in memory
- Automatically searching for the name of the station
- Automatically allocating a programme number.

## WELCOME

Turn on the television set main power.

The WELCOME menu is displayed.

If it is not,

Press the INSTAL button on the television control key pad.

Briefly press the remote control button corresponding to the number of the language you require for the menus.

A list of countries appears (on two pages).

To go to the next or previous page, press

Briefly press the remote control button corresponding to the country in which you are located, for example: England, press

The menu which then appears permits the user to:

- start an automatic search,
- search for new channels,
- access channel organisation.

**!** You can leave the menus at any time by pressing the  button.

## AUTO - PROGRAMMING

For the first time or after a change of region, start automatic channel search by pressing the key Searching for stations and storing them in the memory depends on the language chosen from the WELCOME menu.

*The previously memorised stations are erased.*

*AUTO-PROGRAMMING is completed when the cursor is at the extreme right.*

**!** To interrupt the search, press briefly on the  key. This displays the channel management menu.



A-Z

1

9

A-Z

1

A-Z

1

Z-A

2

3

A-Z

1

WELCOME  
BIENVENUE  
WILLKOMMEN  
BIENVENIDO  
BENVENUTO  
VALKOMMEN  
WELKOM

ENGLISH	Press	key number	[1]
FRANCAIS	Appuyer	sur la touche	[2]
DEUTSCH	Drücken	Sie die Taste	[3]
ESPAÑOL	Pulse	tecla numero	[4]
ITALIANO	Premere	il tasto	[5]
SVENSKA	Tryck	knapp nummer	[6]
NEREDLANDS	Druk op	knop nummer	[7]

CHOOSE YOUR COUNTRY :

UK :	[ 1 ]
FRANCE :	[ 2 ]
GERMANY :	[ 3 ]
ITALY :	[ 4 ]
SPAIN :	[ 5 ]
PORTUGAL :	[ 6 ]
SWISS :	[ 7 ]
AUTRIA :	[ 8 ]
Next page :	[ 9 ]

NETHERLANDS :	[ 1 ]
BELGIUM :	[ 2 ]
LUXEMBOURG :	[ 3 ]
SWEDEN :	[ 4 ]
DANMARK :	[ 5 ]
FINLAND :	[ 6 ]
NORWAY :	[ 7 ]
OTHERS :	[ 8 ]
Previous page :	[ 9 ]

## AERIAL INSTALLATION

Make sure that the aerial cable and decoder (if any) are connected to this TV set.

- [ 1 ] Launch terrestrial installation
- [ 2 ] Update the terrest. installation
- [ 3 ] Access to the organiser

To help you, follow the instructions at the bottom of the menu (grey background).

## AUTO - PROGRAMMING

Searching for stations  
  
 10 stations found

# television set auto-programming

## Programme Organiser

When the automatic search is completed, the Programme Organiser menu appears.

Scan through to check that the stations found are correctly numbered and named as you want them:

• **IF YES** → press briefly

the menu disappears and is replaced by the picture of the programme selected.

• **IF NO** → you make changes as follows

### - The programme number

Select the programme number to be changed.

Bring the cursor to the new programme number.

**!** You may also use the number buttons 0 to 9.

Confirm the change (green button).

### - The station name

Press the blue button briefly.

A list of station names per country appears

United Kingdom	Nederlands
France	Belgique
Deutschland	Luxembourg
Italia	Sverige
España	Danmark
Portugal	Finland
Schweiz	Norge
Österreich	

Select the country you require.

If the name appears in the list displayed,

select the name

Confirm the selection (green button).

If the name does not appear in the list displayed,

select the "-----" line

**!** You have 6 characters to enter a station name

To enter a station name, Press the green button briefly and the first character flashes.

Select the first character of the new name.

Enter the next character and repeat the process up to the last character. Confirm your choice (green button). The new name is stored in the memory and the list disappears.

- This menu is used to :
- change the programme number,
  - change the station number,
  - delete a programme.

**Programme Organiser**

01  
02  
03  
04  
05  
06  
07  
08  
09

PR+, PR- Select a station  
+, -, 0..9 Move this programme  
Blue Change the name  
Yellow Erase this station  
To exit, press the (TV) key

Moving PR 06 BBC to PR 04  
+, -, 0..9 Give it another number  
Green Confirm change  
Red Cancel change

**Programme Organiser**

01  
02  
03  
04  
05  
06  
07  
08  
09

United Kingdom  
BBC 1 SKYONE  
BBC 2 DISCOV  
I T V UKGOLD  
CHAN 4 SKYSP0  
CHAN 5 BRAVO  
SKY+ REPORT  
M-GOLD S-NEWS  
M-CHAN M T V  
CHILD BUNEMS  
C N N -----

+, - Next/Previous name page  
PR+, PR- Select a new name  
Green Confirm change  
Red Cancel change

07  
08  
09

PR+, PR- Select a station  
+, -, 0..9 Move this programme  
Blue Change the name  
Yellow Erase this station  
To exit, press the (TV) key

C N N | -----

+, - Next/Previous position  
PR+, PR- Select a character  
Green Confirm new name  
Red Cancel new name

C N N | SK

+, - Next/Previous position  
PR+, PR- Select a character  
Green Confirm new name  
Red Cancel new name

PR+, PR- Select a station  
+, -, 0..9 Move this programme  
Blue Change the name  
Yellow Erase this station  
To exit, press the (TV) key



# television set auto-programming



## To delete a programme

Select the programme to be deleted.

Press the yellow button.

Confirm your choice (green button).

The programme is deleted  
the following programme is selected.

**!** You may cancel any unconfirmed command (change of programme number or channel name, programme erasure) by pressing the red button.

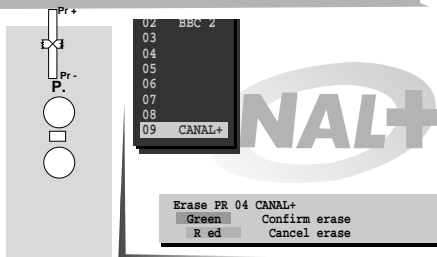

## New channels

Turn on the television set by pressing one of the buttons from 1 to 9.

To search only for new channels.

Press the television set INSTAL button.

Select the country and press the button

When search is finished, the **Programme Organiser** menu appears.

Reorganise the programmes.

To do this, follow the instructions given on the previous page.

**!** To make the menu disappear, press on

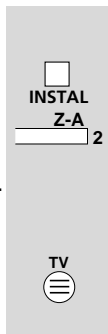

# installation

With this menu you may:

- Limit the maximum volume.
- Change the menu language (German, Spanish, French, English, Italian, Swedish, Dutch),
- Permanently display the number of the programme being watched,
- Store the time reference programme number,

## SET-UP

## PREFERENCES

SET-UP

Press the yellow button then the (-) button.

The **SET-UP** menu is displayed



## Maximum Volume Limitation

Select the **Max. Volume** line (yellow button).

Set the maximum volume with the cursor.

**!** The volume cannot be set to zero when using this function.

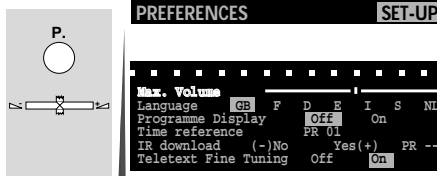

# television set installation



## Menu language

Select the **Language** line (yellow key).

- Select
- |                     |                    |
|---------------------|--------------------|
| <b>GB</b> : English | <b>I</b> : Italian |
| <b>F</b> : French   | <b>S</b> : Swedish |
| <b>D</b> : German   | <b>NL</b> : Dutch  |
| <b>E</b> : Spanish  |                    |

All the menus will be displayed in the language selected.

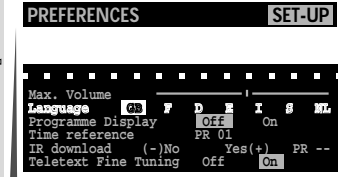
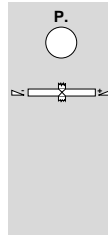

## Programme number display

Select the **Programme Display** line (yellow key).

- Select :
- **Off** no permanent display.
  - **On** the programme number is permanently displayed

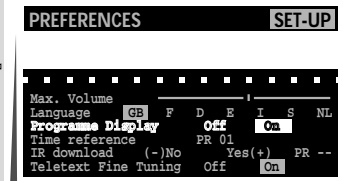
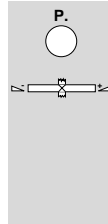

## Time reference

Select the **Time reference** (yellow key).  
The television set internal clock must be set.  
This synchronises automatically when the television set is turned on to a programme broadcasting Teletext, you can opt to select any one of the 4 channels - BBC1, BBC2, ITV, CH4.  
Select the corresponding programme number.

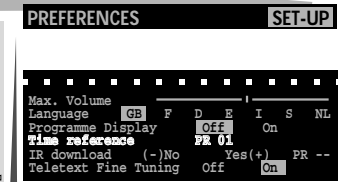
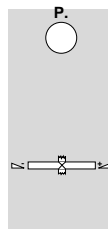

**!** *The IR download line has no effect on your TV set.*

## Teletext fine tuning

This adjustment allows writing errors (missing letters) on the teletext pages of French networks (L Standard) to be reduced.  
To do this, **On** must be selected in the Teletext Fine Tuning line.

**!** *This adjustment is not active for the B, G, D, K, K' and I standards.*



## PREFERENCES

This menu enables you to save your preferred settings.  
Press the yellow or pink key repeatedly to return to the Menu contents line.

Press to display the **PREFERENCES** menu.

Select the line required with the yellow key.

Set with the key.

Erase the menu.

To return to your preferred settings at any time, press the pink key.

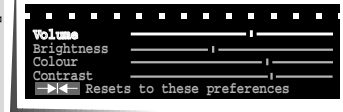
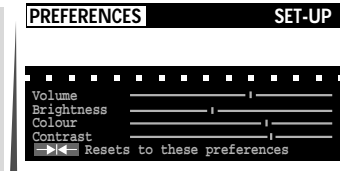
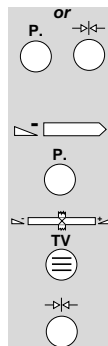

# television set

## picture adjustments





You may adjust the picture settings at any times.

### PICTURE

Press the green key.

The PICTURE menu is displayed :  
PICTURE is selected.

**!** If this is not the case, select the Contents line using the green key  and Picture with the  key.

Select the Brightness line (green key).

Adjust the brightness.

Repeat the same procedure to select and adjust the Colour, and Contrast.

**!** The TINT line only appears if the source is NTSC from an AV1, AV2 or AV3 audio-visual programme.

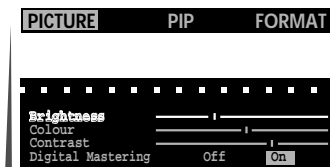
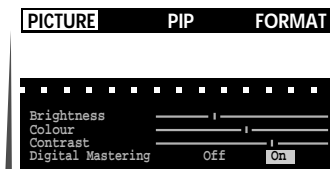

### Digital Mastering

Select the Digital Mastering line (green key).

Select the option required.

**!** When changing channels, Digital Mastering automatically returns to On.

*This process suppresses flicker from the TV image. In addition, Digital Mastering improves image quality with a further reduction of the trembling effect. The images are more stable, sharper and less straining to the eyes. Finally, image noise is reduced automatically according to reception quality (INR system : Intelligent Noise Reduction).*



### PIP (Picture in picture)

Gives you several possibilities for programmes inlays.

You use this function to :

- inlay in one of the corners of the screen (P I P) :
  - images from the input connectors (AV1, AV2, AV3 or RGB), while viewing a channel ;
  - or one of the channels, while viewing a programme from one of the audiovisual input connectors (AV).
- inlay on the screen in groups of 9, all the channels in memory (Channel guide).

Press the green button once or several times to select the Contents line.

Select P I P.  
The PIP menu appears.

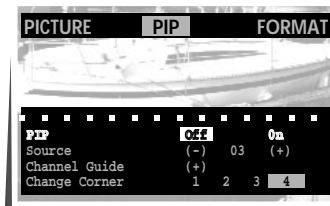

# television set

## picture adjustments



### Image inlay (PIP)

Use the green button to select the **PIP** line.

Press briefly to select : **Off** : no picture in picture  
**On** : picture in picture

Use the green button to select the **Source** line.

As required select :  
the AV1, AV2, AV3 or RGB picture,

or a channel in memory.

**!** *Picture in picture is in 4/3 or 16/9 format depending on the format of the AV image.*

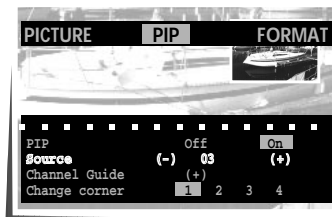
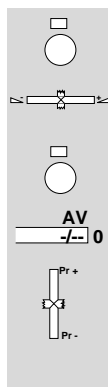

### Inlaid image position

Use the green button to select the **Change corner** line.

Select position 1, 2, 3 or 4.

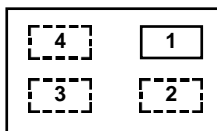

Press to erase the menu.

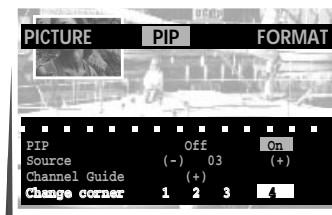
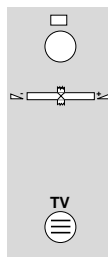

### Picture swap

Press the  button

to swap the image being viewed and the PIP image.



### Scanning all inlaid image programmes

Select an AV image on the screen.

Repeatedly press the PR +/- button on the remote control to scroll through PIP displays of all stored programmes and the other AV programmes.

Press a long time to remove the PIP.

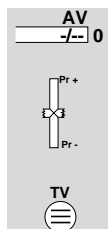

# television set

## picture adjustments



You can display on the screen, in group of 9, all the channels stored in memory.

### Mosaic

Press the green button once  
To select the Contents (Summary) line.

Select PIP.

Press the green button repeatedly  
to select Channel Guide.

Press the key.  
The screen goes grey and the channels become inlaid  
With the corresponding programmes numbers superimposed.

The Channel Guide programmes change every 3 seconds.

When the Channel Guide appears,  
the sound goes off.

To display the programme you want on screen,  
press the button when the image of that  
programme is animated

**!** *Activating the Channel Guide feature cancels any inlays.*

To clear the Channel Guide, press the TV button.



### FORMAT

Press the green button once to select the Contents line.

Select FORMAT.

The following menu is displayed.

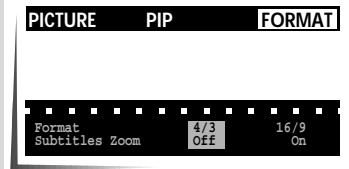
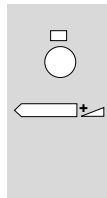

### Format

Select the Format line (green key).

Select 4/3 or 16/9 depending on the picture format.

*The Subtitles Zoom line only appears when 4/3 is selected*

**!** *The format can also be selected automatically when the source is one of the two Euro-AV sockets AV1 or AV2. In this case, select AUTO which is only displayed for sources AV1 and AV2. The format is stored in memory for AV1, AV2 and AV3.*

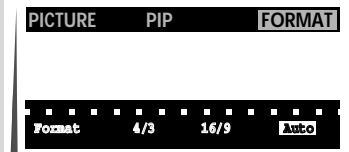
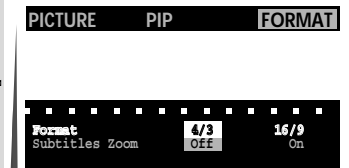
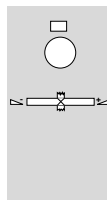

GB

# television set picture adjustments



## Subtitles Zoom

Select the **Subtitles Zoom** line (green key).

You may select  **Off** : programme without subtitles  
 **On** : subtitled programmes.

In this case, an additional line (**Subtitles position**) appears

You may choose between a higher or lower framing, for example, for sub-titled programmes.

Select **Subtitles position** (green key),  
then set your picture lift.

Remove the menu from the screen.

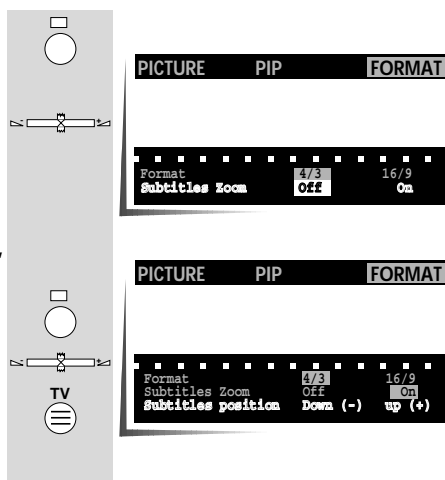

# television set sound adjustments

## Dolby\* Surround Pro Logic

Derived from the DOLBY-STEREO system used in cinemas, Dolby Surround Pro Logic enables you to re-create the acoustic environment of the cinema in your own home (with a DOLBY - STEREO signal), or to obtain enhanced sound effects (with a mono or stereo signal).

You have three options :

- Connect two sets of speakers (Pro Logic),
- Connect one set of speakers (Dolby Phantom or Dolby 3 Stereo),
- Use the television sound system only (Pro Logic mode off).

Make sure that the following steps are carried out in the order shown.

- Turn off the television at the main power switch.
- Connect the speakers to the appropriate sockets and make sure that the black speaker terminals on the speakers are connected to the black terminals on the television, and likewise for the red terminals.
- Configure the television for the speakers that are connected or for the acoustic effect you wish to obtain.
- Balance the acoustic environment.

When these steps have been completed, you can carry out the other sound settings.

\* " DOLBY " and the double D symbol are registered trade-marks belonging to the Dolby Laboratories Licencing Corporation.

# television set sound adjustments



## CONNECTING THE SPEAKERS

To benefit from the Dolby Surround Pro Logic system, you must connect to your television set 4 loudspeakers :

- 2 front speakers
  - 2 surround speakers
- } Speakers, ref. DPL 4 K delivered

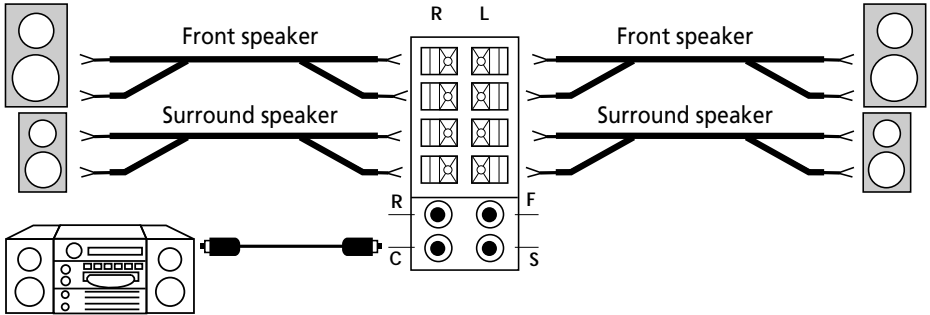

To select the speakers you have connected, you must configure your television set :

## SPEAKER CONFIGURATION

The following menu is displayed:

Select the Configuration line.

Depending on the speakers connected, or the audio effect preferred, choose one of the configurations offered.

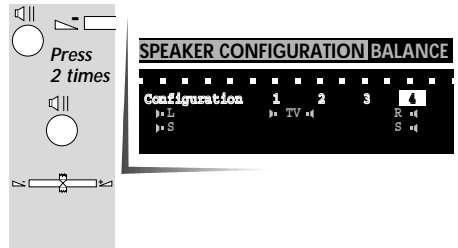

CONFIGURATION		ACOUSTIC EFFECT	
		Mono signal	Stereo signal
1	TV speakers only	Stereo effect	Wide stereo
2	TV speakers + Front speakers	Stereo effect	Wide stereo or Dolby 3 Stereo
3	TV speakers + Surround speakers	Matrix*	Dolby Surround or Hall
4	TV speakers + Front speakers + Surround speakers	Matrix*	Pro Logic or Hall

\*Matrix : sound delay in the rear speakers.

Press briefly to remove the menu.



# television set sound adjustments



## LOUDSPEAKERS

Press the red button  
The following menu is displayed: LOUDSPEAKERS is selected.

**!** *If this is not the case, select the Contents line with the red key and LOUDSPEAKERS with*

Select the **SOUND** line.

This varies depending on the sound type received:

SOUND	MONO/STEREO or NICAM Stereo*
SOUND	DUAL (2 languages)
SOUND	NICAM 3*
SOUND	AV

Select the required sound for the loud speakers.

**!** *For normal operation, AUTO/STEREO position is recommended. STEREO or MONO will be selected automatically depending on the signal received.*

\*NICAM is a digital sound transmission system, it enables you to receive broadcasts in high quality STEREO or DUAL SOUND. Analogue MONO sound is transmitted simultaneously, (MONO in NICAM STEREO or SOUND 3 in NICAM 3).

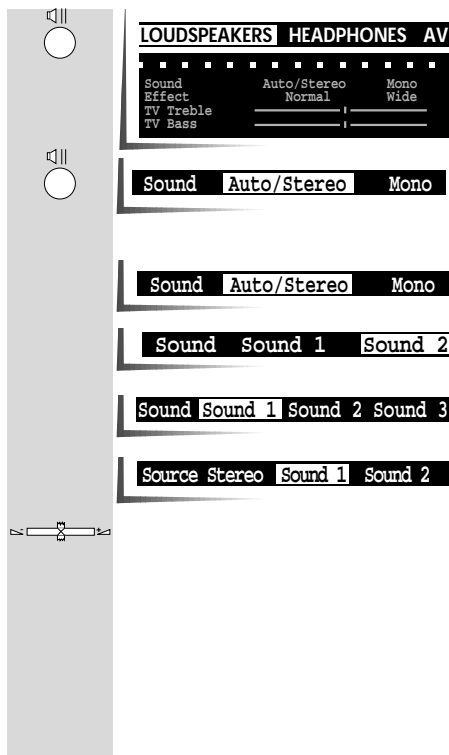

## Effect

Select the **LOUDSPEAKERS** line

**!** *The number and type of selections available varies according to the configuration selected (see p. 15).*

Depending on the selected configuration, you will be able to choose between 2 or 3 of the following options:  
Normal, Wide, Hall, Dolby.

Select the type of sound required.

According to which selection and configuration is chosen (see page 15), you will obtain one of the sound effects shown on the table below.

When the type of sound received changes (mono to stereo or vice versa), the sound effect automatically becomes that selected for the type of sound received.

Press briefly to remove the menu.

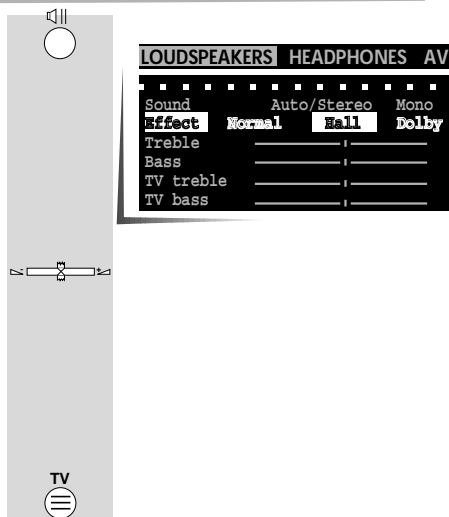



# television set sound adjustments



CONFIG. AUDIO	SOUND	EFFECT SELECTION			
		Normal	Wide	Hall	Dolby
1	Mono	Mono	Pseudo-Stereo		
	Stereo	Stereo	Wide stereo		
2	Mono	Mono		Pseudo-Stereo	
	Stereo	Stereo	Wide stereo		Dolby 3 Stereo
3	Mono	Mono		Matrix	
	Stereo	Stereo		Hall	Dolby Surround
4	Mono	Mono		Matrix	
	Stereo	Stereo		Hall	Pro Logic

## BALANCE

Press the SOUND button then the (-) button.  
The following menu is displayed :

The menu varies depending on which configuration is selected.

### • Configuration 1

Select the **Left/Right** line.

Balance the sound between the two audio channels.

### • Configuration 2

Adjust the balance on the front speakers, and the sound level on the central loudspeakers as shown in the chapter **BALANCING THE ACOUSTIC ENVIRONMENT**.

### • Configuration 3

Adjust the balance on the front speakers and the sound level on the surround speakers, as shown in the chapter **BALANCING THE ACOUSTIC ENVIRONMENT**.

### • Configuration 4

Adjust the balance on the front speakers and the sound level on the surround speakers, as well as the sound level on the central loudspeakers as shown in the chapter **BALANCING THE ACOUSTIC ENVIRONMENT**.

Press briefly to remove the menu.

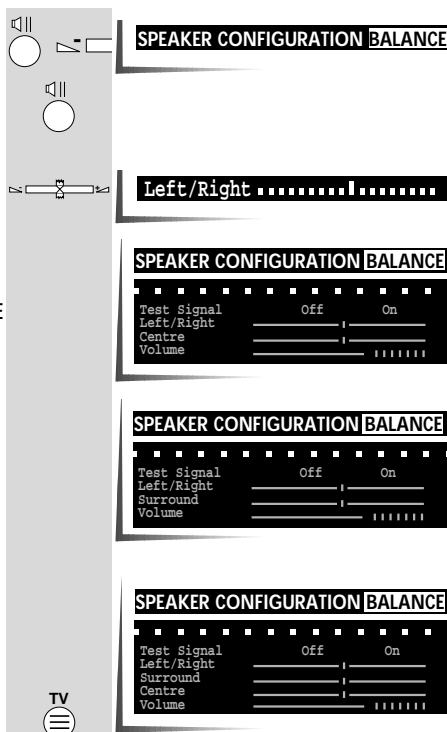

GB



# television set sound adjustments



## BALANCE THE ACOUSTIC ENVIRONMENT

When you have selected the configuration you require, you can then balance the acoustic environment (except for selection 1 : TV only).

The instructions given below explain how to set up the configuration (selection 4).

With the **BALANCE** menu displayed  
Select the **Test Signal** line.

Press the + or - button to highlight **On** in red letters.

The sound from the programme being watched is replaced by a "white noise" sound which is transmitted to each of the channels in turn (Left, Center, Right and Surround).  
The adjustment consists of balancing the sound level of the four channels so that the noise has the same sound level on each of them.

Select the **Left/Right** line

Balance the sound level for the speakers on the right and on the left.

Select the **Surround** line.

Using the + or - buttons, increase or reduce the sound level for the rear speakers (Surround).

Select the **Centre** line.

Increase or reduce the sound level on the television speakers.

The above settings are correct when the sound level for the noise is identical on each of the channels.

Press repeatedly to select the **Test Signal** line.

Briefly press the + or - buttons to highlight **Off**.

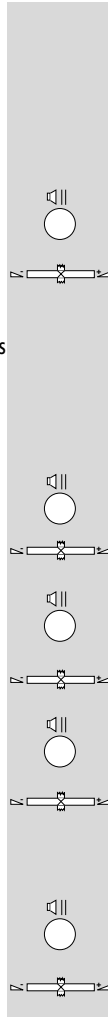

### SPEAKER CONFIGURATION BALANCE

Test Signal	Off	On
Left/Right	_____	_____
Surround	_____	_____
Centre	_____	_____
Volume	_____	

Test Signal	Off	On
Left/Right	_____	_____
Surround	_____	_____
Centre	_____	_____
Volume	_____	

### SPEAKER CONFIGURATION BALANCE

Test Signal	Off	On
Left/Right	_____	_____
Surround	_____	_____
Centre	_____	_____
Volume	_____	

Test Signal	Off	On
Left/Right	_____	_____
Surround	_____	_____
Centre	_____	_____
Volume	_____	

Test Signal	Off	On
Left/Right	_____	_____
Surround	_____	_____
Centre	_____	_____
Volume	_____	

Test Signal	Off	On
Left/Right	_____	_____
Surround	_____	_____
Centre	_____	_____
Volume	_____	

## TONE ADJUSTMENT

The following menu is displayed :  
**LOUDSPEAKERS** is selected.

Select the **Treble** and **Bass** lines in turn, and

increase or reduce the treble or bass frequency level on the speakers, and the level on the front speakers if they are connected.

Press briefly to remove the menu.

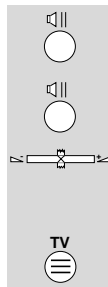

### LOUDSPEAKERS HEADPHONES AV

Sound Effect	Auto/Stereo	Mono
	Normal	Hall
		Dolby
Treble	_____	_____
Bass	_____	_____
TV Treble	_____	_____
TV Bass	_____	_____



# television set sound adjustments



## HEADPHONES

Press briefly

The following menu is displayed :  
HEADPHONES is selected.

**!** If this is not the case, select the Contents line with the red button  and HEADPHONES with .

Select the Headphone line (red key).

You can then adjust the volume for the headphone.

**!** Note : When the transmission is multilingual (DUAL) or an AV programme, the following menu appears. It is possible to select Sound 1 or Sound 2 in the headset.

Select the Source line:

then select

Sound 1

or

Sound 2

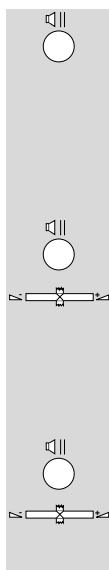

LOUDSPEAKERS HEADPHONES AV

Headphones

Headphones

Source Sound 1 Sound 2  
Headphones



GB

## AV

The sound output on sockets AV1 and AV2 must be adjusted according to the type of headset connected.

Press briefly.

The following menu is displayed :  
AV is selected.

**!** If this is not the case, select the Contents line with the red key  and AV with .

Select the AV Device line (red key).

Then select

Stereo	= stereo VCR
Mono	= mono VCR

**!** Selecting stereo permits simultaneous recording of both languages of a bilingual programme on a stereo video recorder : Sound 1 on the left track and Sound 2 on the right track.  
The sound available at the AV1 and AV2 outputs must be adjusted according to the type of device connected.

Press to remove the menu from the screen.

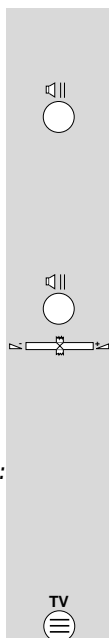

LOUDSPEAKERS HEADPHONES AV

AV Device

Stereo Mono

LOUDSPEAKERS HEADPHONES AV

AV Device

Stereo Mono



# television set day to day operation



## SWITCHING ON / SELECTING PROGRAMMES

Switch on the television set with the mains switch if the standby light is off.

If the standby light is on, select the programme required by the remote control or the PR/+ buttons on the front of the set.

**For the programmes 1 to 9 :**

Press the corresponding number briefly.

**For programmes 10 to 99 :**

Hold on to display the tens.

Press briefly to display the units.

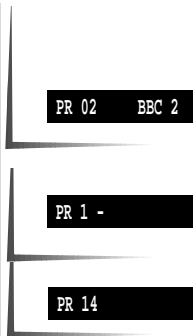
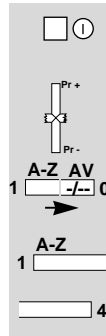

## BROWSE

This comprises 10 pages of 10 programmes each, giving for each programme number : the station name (if it has been programmed).

The **BROWSE** menu is displayed.

To select the directory page displayed.

To select the other pages, press repeatedly.

Example : Page 6 (programmes 50 to 59)



*To select a programme from the page displayed, press only the unit digits of the programme selected (example for 53: press 3).*

**!** Programme PR 00 corresponds to the last audiovisual programme (AV1, AV2 or AV3).

Press briefly to select **BROWSE** again.

Press briefly to remove the directory from the screen.

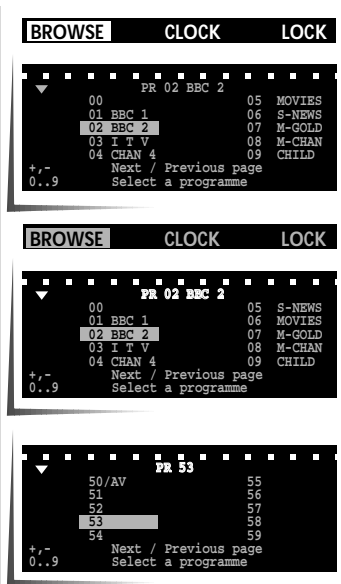
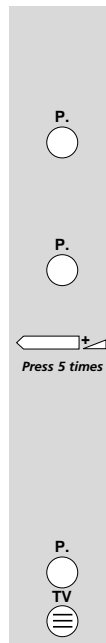

## Volume

Set the volume as desired.

When the headphones are plugged in, you can adjust the volume of the headphones or loudspeakers :

Select the line you wish to adjust

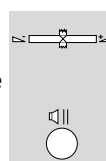

## Sound mute

Pressing once turns the sound off. The sound returns if the button is pressed once more.

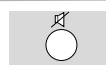

Mute

# television set

## day to day operation



### RETURN TO PREFERRED SETTINGS

Press briefly to return to personal adjustments (PREFERENCES menu)

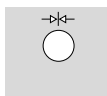

### DISPLAY / ZAPPING

Displays details of the station being watched (programme name and number, time).

Press repeatedly to scroll through the programmes.

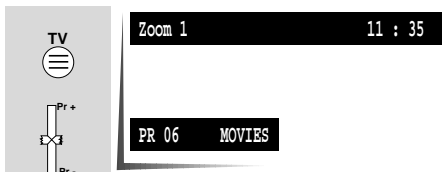

### PICTURE FREEZE

Press key,  
The picture freezes instantly.

The transmission continues.

**!** *The still picture cannot be recorded.*

Press briefly to return to the programme being viewed.

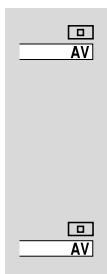

### LAST PROGRAMME VIEWED

This function is used to switch rapidly between 2 programmes.

Press the key.  
The previously viewed programme is selected.



### ZOOM

Press to enlarge or reduce the image.

ZOOM 0 → ZOOM 1 → ZOOM 1 S/T → ZOOM 2

ZOOM 0 ← ZOOM 1 ← ZOOM 1 S/T ← ZOOM 2

Zoom S/T : image enlarged and moved up for easier reading of subtitles

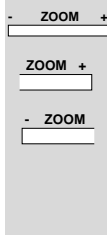

### STAND-BY

Press briefly, the Stand-By light turns red to indicate that the set is now in standby.

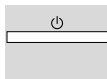

### AUTOMATIC STOP

The set is automatically switched to standby a few minutes after the station being watched stops broadcasting.

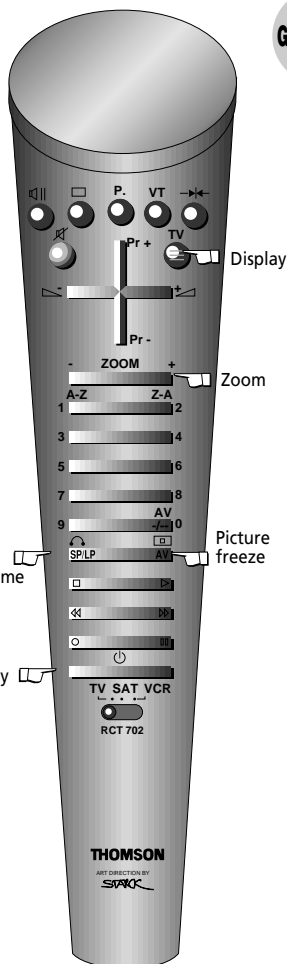

GB

# television set

## other functions - extras



### CLOCK

Select **CLOCK**

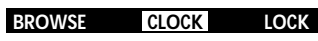

The **Sleep-timer** line is displayed.



### Sleep-timer

Select the **Sleep-timer** line (yellow key).



Set the time in steps of 15 minutes (up to 4 hours).



Remove the menu from the screen.  
The set will switched to standby at the end of the timer interval.



You can display the time left before the stop time.  
Press the **TV** key briefly



One minute before sleep timer time, the screen displays that sleep timer is imminent.

**!** *The standby lamp flashes to indicate the CHILD LOCK state.  
The television set can only be turned on with the remote control.*

You may cancel sleep timer command.

Select the **Sleep-timer** line.



Press repeatedly to return to : - : -



Remove the menu from the screen.



Putting the television set on standby when a sleep timer command is programmed, also cancels this function.

### Clock (automatic on)



You can programme your television set to switch on automatically to the programme of your choice.  
Check that the internal TV clock is set to the correct time.

Press briefly on the key.

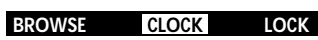

Select the **CLOCK** menu.



Select the **Wake-up time** line (yellow key).



The first figure flashes.

# television set

## other functions - extra



To set the clock to the right time.

Enter the **Wake-up time** using 24 hour format.

Select the **Mode** line (yellow key).

Select 

Off	= the alarm is off
Once	= the alarm will only go off once
Daily	= the alarm will go off everyday

**!** *If a new alarm is programmed, Once is selected automatically.*

Select the **Programme**, line (yellow key).

Select the programme for the alarm.

Remove the menu from the screen.

Turn the television set on to standby.  
It will turn on automatically at the time programmed  
and turn off one hour after.



If the set is switched on before the alarm function is  
activated, it will not switch to the programme selected for  
the alarm at the programmed time.

It is possible to programme both the automatic switching  
off (STANDBY) and switching on (ALARM) of the set. In  
this case the automatic switching on time must be  
programmed to take place after the switching off time.

### CHILD LOCK

You can prohibit the use of your television set using the keypad.

Use of the TV set is prohibited :

- after the sleep timer function ;
- when the set is switched to standby and a sleep timer command is programmed ;
- when the set is turned off at the mains and a sleep timer command is programmed ;
- when a wake up command is programmed,
- after switching off the TV set by holding down the standby button on the remote control for more than 3 seconds.

The **CHILD LOCK** function is indicated by the flashing of the indicator lamp.

**!** *The set can only be switched back on using the remote control.*

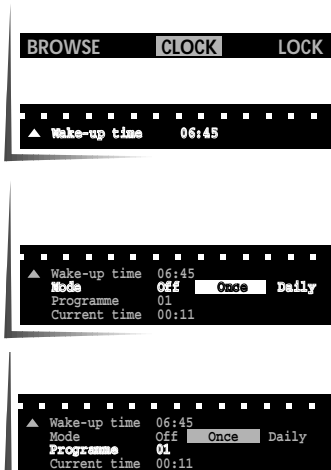
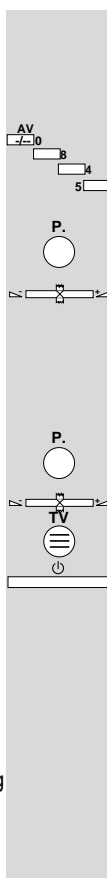

GB



# television set

## other functions - extra

This function enables you, for example, to prevent your children from watching certain programmes by "locking" it so that the set cannot be switched on. The set can be "unlocked" with a PIN number

### LOCK

Press the yellow key to select the menu Contents line,

then the volume (+) key to select LOCK. The following menu is displayed.

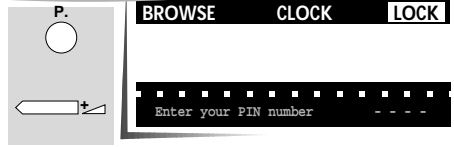

### Enter your PIN number

Press the yellow key briefly to select the line Enter your PIN number.

Then enter your PIN number figures (example : 1111). The menu displays :

Press the yellow button briefly to select the line Store your PIN number.

Press the volume (+) key briefly. The code is stored in the memory and the menu displays :

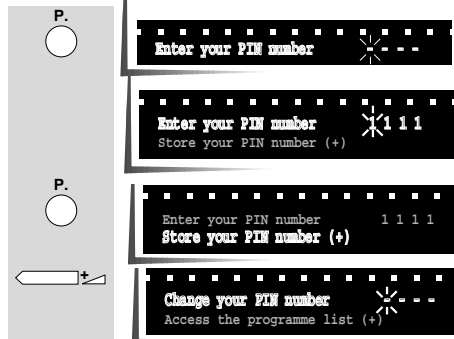

### Change you PIN number

If your previous code has been divulged.

Enter the your new code numbers (example : 1234).

The previous menu then returns.

Press the yellow button briefly to select the line Store your PIN number.

Press the volume (+) key briefly. The new code is stored in the memory and the menu displays :

**!** When you enter a code for the first time, the figures replace the dashes ; where not, the dashes are replaced by an asterisk.

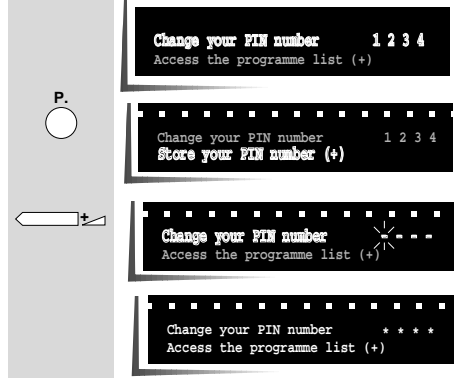

### Access the programme list

Press the yellow key briefly to select the line Access the programme list (+).

Press the volume (+) key briefly. A page of the directory appears depending on the programme being watched (example : page 1, programme 6 : MOVIES).

Select the programme you wish to Lock or Unlock :

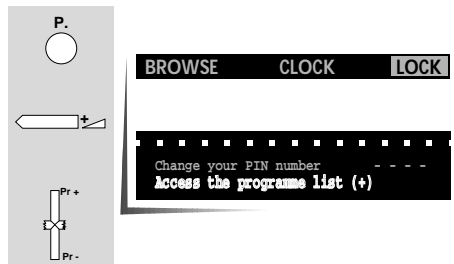



# television set

## other functions - extra



To **Lock**, briefly press the zoom (+) key  
the programme locked turns to red,

or

To **Unlock**, briefly press the zoom (-) key  
the programme unlocked turns to blue.

To lock or unlock other programmes :

- Select the directory range with the keys
- Select the programme, including the audiovisual programmes AV1, AV2 or AV3 with keys
- **Lock** the programme with the key
- **Unlock** the programme with the key

After locking or unlocking all of the required programmes, erase the menu with the key TV.

The locked programmes cannot be obtained using the PR +/- keys on the remote control and the keypad.

If they are selected using the remote control number buttons, the following message is displayed on the screen :

- If you do not enter the right code, the message **Incorrect PIN number** will appear above the first one. The programme does not change and after a few seconds, both messages disappear.
- If you enter the right code, the programme selected appears immediately.

**!** *When the code is entered once to unlock a programme, all of the programmes which were locked are also unlocked. The lock will be re-activated after the set is turned off.*

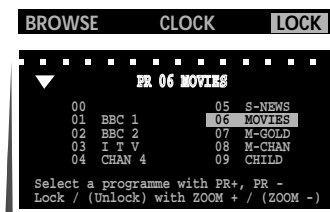
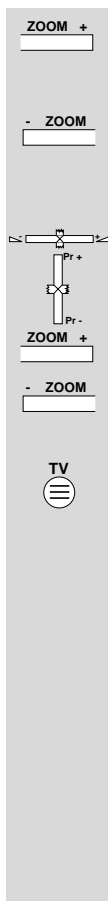

### ACCESS TO THE STATION TUNING MENUS

When there is at least one programme locked, access to the station tuning menus **Auto-Programming** and **Manual Programming** is also locked.

If you call up one of these menus, the following message appears on the screen.

Briefly press the yellow key to select the line  
**Enter your PIN number** if it is not already selected.

Enter your code number and the menu appears immediately  
If the code is not correct, the message **Incorrect PIN number** appears for a few seconds.

**!** *If you forget your personal code, see last page of instructions booklet.*

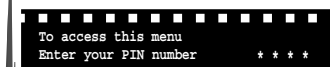
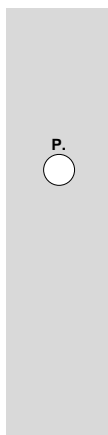

GB

# television set connections



## VIDEO RECORDER CONNECTIONS

### VIA THE AERIAL SOCKET

Refer to your VCR manual

To tune your TV into your VCR you should refer to Manual Programming (page 34).  
The channel number (usually 36 or 60) is given in the manual of your VCR. The programme selected for your VCR must be 9, 19 or 29.  
Whenever you wish to use your VCR, you must select the programme assigned to it.

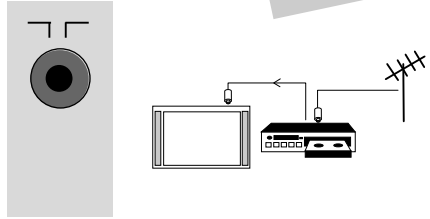

### VIA THE EURO-AV SOCKET 1 (AV1)

This is used to connect :

- Satellite receiver or decoder
- a VHS or 8mm video recorder or camcorder (VIDEO) or a S-VHS or Hi-8mm video recorder or camcorder (S-VIDEO)
- a PC or video games console (RGB).

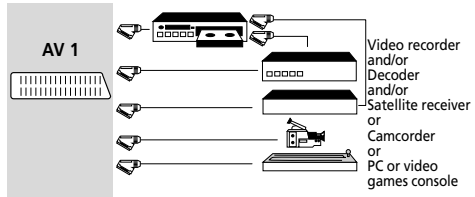

### VIA THE EURO-AV SOCKET 2 (AV2)

This is used to connect :

- a VHS or 8mm (VIDEO), S-VHS or Hi-8mm (S-VIDEO) video recorder.

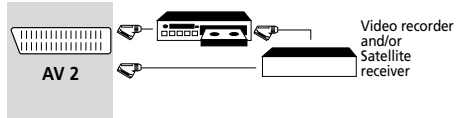

*If you have two VCRs connected, the decoder must be connected to the VCR connected to the Euro-AV1 socket.*

**!** *If you have a satellite receiver, refer to the operating manual in order to find out the type of signal delivered then select VIDEO, S-VIDEO or RGB.*

*You can also connect it to the decoder socket of the second VCR if the latter is fitted with one.*

### VIA THE AUDIO/VIDEO/S-VIDEO SOCKETS (AV2)

This is used to connect :

- an S-VHS or Hi-8mm video recorder (S-VIDEO)(S and AUDIO sockets).

**!** *In order to maintain the optimum sound and picture quality of your set, it is recommended not to connect 2 units to the Euro- AV1 socket and the AUDIO/VIDEO/S sockets simultaneously.*

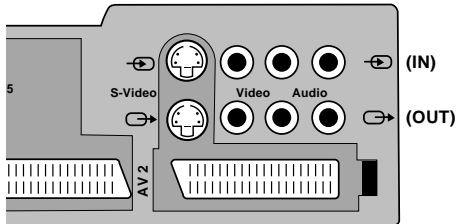

### VIA THE AUDIO/VIDEO/S-VIDEO SOCKETS (AV3)

This is used to connect :

- to a camcorder VHS or 8 mm (VIDEO)(VIDEO and AUDIO sockets) S-VHS or Hi 8 mm (S-VIDEO)(S and AUDIO sockets).

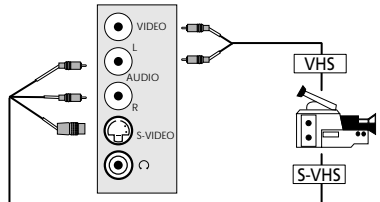

# television set connections



Your television set selects and automatically displays in the menu the type of signal (Video or S-Video) for the equipment connected.

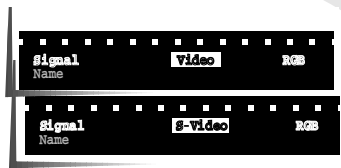

## UNITS CONNECTED

	EURO AV 1	EURO AV 2	AUDIO/VIDEO/S-VIDEO AV 2 SOCKETS	AUDIO/VIDEO/S-VIDEO AV 3 SOCKETS
PAY-TV decoder	VIDEO Automatic selection	VIDEO Automatic selection		
Satellite receiver	VIDEO Automatic selection	VIDEO Automatic selection		
Video recorder VHS/S-VHS	VIDEO/S-VIDEO Automatic selection	VIDEO/S-VIDEO Automatic selection		
Camcorder			VIDEO/S-VIDEO Call AV 2 <input type="checkbox"/> AV <input checked="" type="checkbox"/> 0	VIDEO/S-VIDEO Call AV 3 <input type="checkbox"/> AV <input checked="" type="checkbox"/> 0
PC / Games console	Select RGB Call AV 1 <input type="checkbox"/> AV <input checked="" type="checkbox"/> 0			

GB

## Name

You may give each piece of equipment connected a name. Call up the AV 1, AV 2 or AV 3 menu.

Select the Signal line (yellow key).

Check the type of signal or select as necessary.

Select the Name line. The first dash flashes.

You may enter the name of the channel using 6 characters. Continue to press, the signs, figures and letters are displayed in alphabetical order.

Continue to press : the letters are shown in reverse order. When the required character appears, go to next character.

**!** To leave a space look for the blank character (between ? and A).

P.  ←

P.

P.  ← →

A-Z 1

Z-A 2

← →

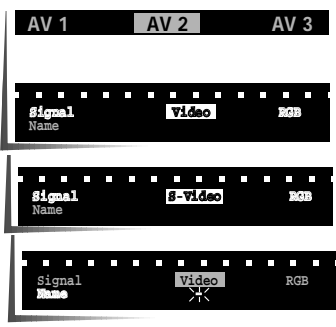

## CALLING UP AUDIOVISUAL PROGRAMMES

Press AV to call AV1, AV2 or AV3 programmes in sequence. In most cases, the television set changes automatically to AV1, AV2 or AV3, when the VCR connected is in play back mode. When the VCR is stopped, the TV set returns to the station previously watched.

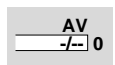

**!** The TV set changes automatically to 16/9 format if the unit connected supplies the control voltage and if you have selected AUTO from the FORMAT menu.



## COPYING VIDEO TAPES

It is necessary to have 2 VCRs with the same specifications : 2 VHS/8 mm or 2 S-VHS/Hi-8 mm.

Connect the playback VCR to the Euro-AV1 socket in playback mode.  
Connect the recording VCR to the Euro-AV2 socket in recording mode.

**!** *During the copying of the tape, you can watch the station you are copying.*

	PLAY		CALL UP PROGRAMME	RECORD	
	EQUIPMENT	SOCKET		EQUIPMENT	SOCKET
VHS or S-VHS	Video recorder	Euro-AV 1	AV 1	Video recorder or Camcorder	Euro-AV 2 Audio/S-Video AV 2
	Camcorder	Audio/Video/S-Video (Right side)	AV 3	Video recorder or Camcorder	Euro-AV 2 Audio/S-Video AV 2

## SPEAKERS CONNECTIONS (OTHER OPTIONS)

### CENTRAL SPEAKER

- **Direct connection**

If preferred, one or two speakers can be connected to replace the loudspeakers on your television set, as shown below :

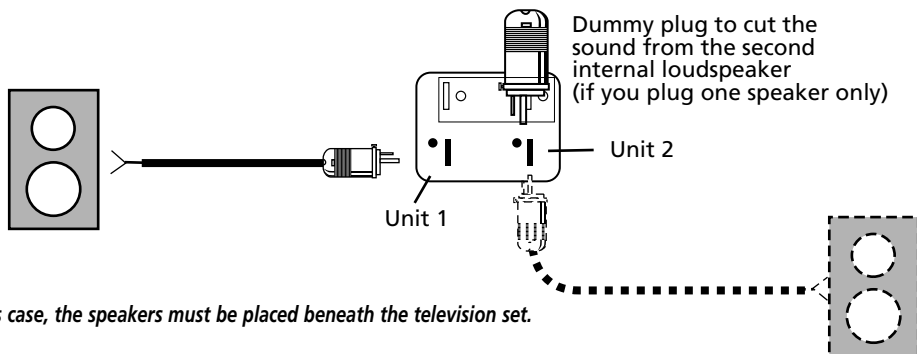

## CONNECTION TO A HI-FI SYSTEM

To boost the audio power, you may connect a Hi-Fi system, if you have one.

You must however avoid connecting your Hi-Fi and speakers to similar outputs (e.g. Hi-Fi on the CINCH surround socket and speakers on the surround clips).

In this case, the configuration of the television set will match that described on page 15.

**!** *For a full appreciation of Dolby Surround Pro Logic, your television set should be placed in a spacious room.*

# television set connections



## • Dolby Surround Pro Logic

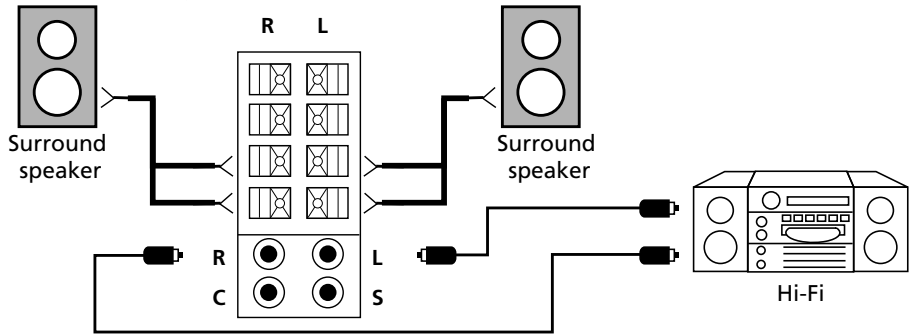

After making the connection, choose **configuration 4** from the **SPEAKER CONFIGURATION** menu, and **Dolby** from the **LOUDSPEAKERS** menu.

Then proceed to the adjustment of the audio environment.

To do so, call up the **BALANCE** menu (page 17) and proceed as shown.

**!** You should also adjust the volume of your Hi-Fi.

If you have an amplifier or another Hi-Fi :

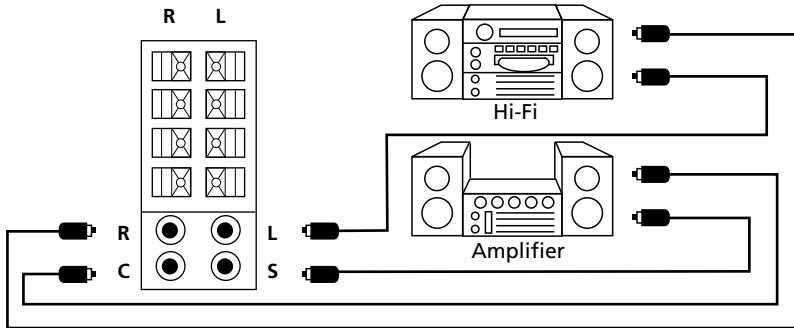

Dummy plug :  
Cut the sound  
from the internal  
loudspeaker

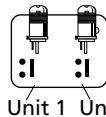

Dummy plug :  
Cut the sound  
from the internal  
loudspeaker

After making the connection, choose :  
- **configuration 4** from the **SPEAKER CONFIGURATION** menu  
- **and Dolby** from the **LOUDSPEAKERS** menu.

Then proceed to the adjustment of the audio environment.

To do so, call up the **BALANCE** menu (page 17) and proceed as show.

**!** You should also adjust the volume of your Hi-Fi.



## • WIDE STEREO/Dolby 3 Stereo

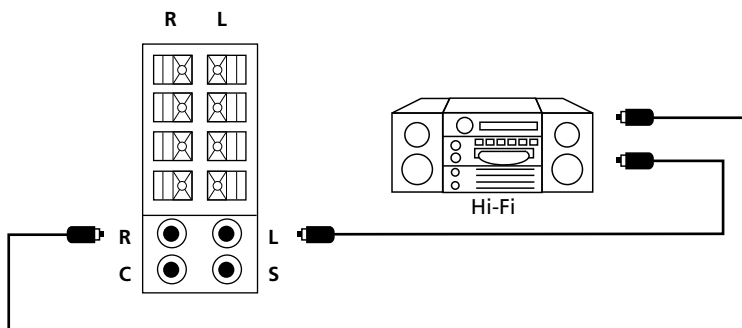

After making the connection, choose :

- **configuration 2** from the **SPEAKER CONFIGURATION** menu
- and from the **LOUDSPEAKERS** menu to obtain wide stereo
- or **Dolby** to obtain Dolby 3 Stereo sound.

Then proceed to the adjustment of the audio environment.

To do so, call up the **BALANCE** menu (page 17) and proceed as shown.



*You should also adjust the volume of your Hi-Fi.*

## FITTING BATTERIES

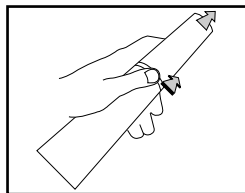

To open the cover, press as indicated and push in the direction of the arrows.

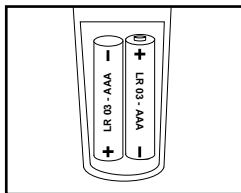

Insert two LR 03 1.5 V batteries.

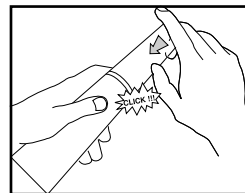

Close the battery-compartment cover.



*For a cleaner environment, please dispose of used batteries in the containers provided for this purpose.*

# television set

## teletext



Your television set is equipped to receive teletext. There are 3 types of teletext :

- Teletexte (France-Europe),
- Fastext (UK, Spain),
- Toplevel (Germany)

- !** *If you notice writing errors (missing letters) on the teletext pages of French networks (L Standard), check:*
- That you have good reception,
  - That **On** is selected in the Teletext Fine Tuning line of the SET-UP menu (see page 10).

### CALLING UP TELETEXT

Select a station on which there is Teletext (for France, TF 1, FR2).

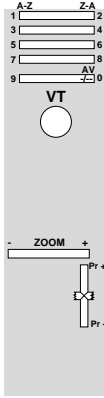

Briefly press the blue key.  
The contents page (Page 100) appears automatically.

You may enter the page number required (3 figures).  
Example: page 170, enter 1, 7, 0 (the number is displayed at the top left of the screen).

When the page is found, it appears on the screen.  
You can move through the pages to select them.

- !** *While the teletext is displayed, you may adjust or turn off the volume.*
- To quit Teletext, press .

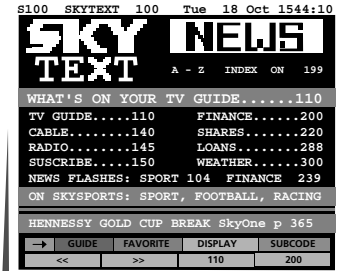

### OPTIONS

See next page

The two menu lines, under the Teletext page, are different, depending on the type of Teletext received (Teletext, Fastext, Toplevel) and your selection (see page 32).

You may select different options using the top line of this menu. These are shown in colour.  
Briefly press the corresponding colour key (red, green, yellow, blue).

The menu bottom line is then activated.

To select options from the bottom line, press the equivalent colour button.

- !** *To return to the first line of the menu, press the pink key.*

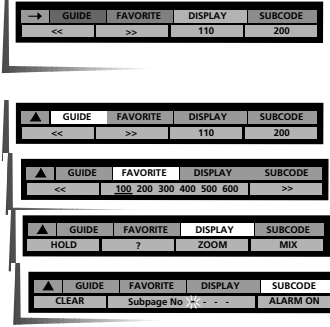
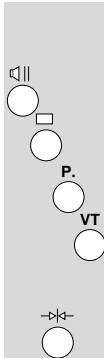

### ALARM











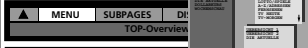
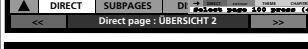
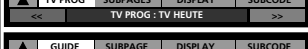

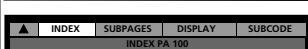







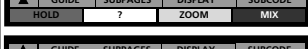

If the teletext transmits an alarm page, you can make it come up at a set time.

While entering the number of the alarm page (E. G. TVE : 697, ORF : 784). Then enter the digits to choose the time ( e.g., for 20.45, type 2, 0, 4, 5) and hold down the last digit until the teletext is removed.

At the chosen time, the alarm page will appear on the screen.

To erase the alarm page, first press the blue key then the key .

When the red and green rectangles are displayed in these menus, pressing the red key displays the previous page, pressing the green key displays te next page.

Key	Type	Name	Functions	Menus
Red 	TOPTXT	MENU	Displays <b>Top</b> text menu (red key).	
		DIRECT	Directly displays the <b>priority pages</b> determined by the station (red and green keys).	
		PREVIEW	Displays <b>TV programme</b> page (red and green keys)	
		GUIDE	Displays <b>subject</b> (yellow key) or <b>field</b> (blue key)	
	FASTEXT	INDEX	Calls up <b>Contents</b> page (red key).	
		GUIDE	Selects <b>different heading</b> (red, green, yellow, blue keys)	
TELETEXT	INDEX	Displays <b>Contents</b> page (red key).		
	GUIDE	You may call : <ul style="list-style-type: none"> <li>— • The <b>previous page</b> (red key)</li> <li>— • The <b>next page</b></li> <li>— • The <b>first page of the next ten after the page displayed</b> (yellow key)</li> <li>— • The <b>first page of the next hundred after the page displayed</b> (blue key). Eg : page displayed : 135 -&gt; page called up : 140 or 200</li> </ul>		
Green 	TOPTXT	SUBPAGE	Used to display <b>subpages</b> if any. The number of the subpage displayed is underlined. Select subpages with red or green keys.	
	FASTEXT	FAVORITE	Allows you to store up to 6 of your favourite teletext pages. To store your favourite pages, select one of the 6 locations by using either the red or green keys (the selected location will have its 3-digit number underlined). Then enter the number of the required page. Repeat the process for each favourite page. (There are 6 favourite page locations for each PR number).	
	TELETEXT			
Yellow 	TOPTXT	DISPLAY	<b>!</b> <i>The colour of the buttons depends on the option required.</i>	
			Option selection.	
	FASTEXT	TELETEXT	<b>For games :</b> Briefly press the green key to see a hidden answer.	
			<b>To enlarge the text :</b> yellow key Press once : top half of screen doubled in height. Press twice : bottom half of screen doubled in height. Press three times : return to normal Teletext.	
TELETEXT	TELETEXT	<b>Mix mode :</b> Briefly press the blue key to overlay the Teletext page on the TV picture.		
		<b>If you wish to stop page scrolling (eg : 4/7)</b> Briefly press the red key, the page number replaces «HOLD». Press the red key again to continue scrolling.		
Blue VT 	TOPTXT FASTEXT TELETEXT	SUBCODE	<b>Automatic renewal of the page displayed.</b> Press the yellow key, you can watch your TV programme while waiting for page search to complete.	
			When the page is found, the message «PAGE XXX RECEIVED» appears on the screen. Press the blue button to display the page.	
Blue VT 	TOPTXT FASTEXT TELETEXT	SUBCODE	Enter the <b>subpage</b> number (eg : 0009). Press the green key. The TV picture is displayed and as soon as the subpage is found, it is displayed.	
				





### HOW TO SELECT

Repeatedly press the pink key to select the possible options under the required colour.

- Red key** : MENU, DIRECT, PREVIEW, GUIDE (Toptext)  
INDEX, GUIDE (Teletext or Fastext)
- Green key** : FAVORITE, SUBPAGE
- Yellow key** : DISPLAY, UPDATE
- Blue key** : SUBCODE.

Briefly press the same colour key (red, green, yellow or blue) to select.

To save your choice, briefly press the (+) button.

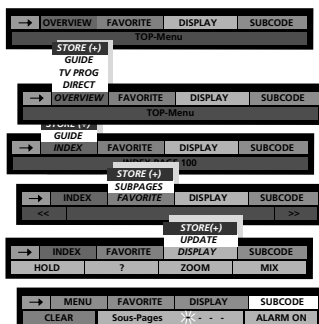
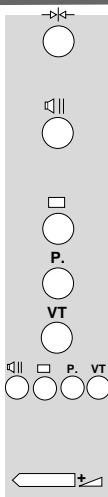

### SUBTITLES

Some programmes are transmitted with subtitles for the hard of hearing. These subtitles are received via Teletext on a special page number. They can be superimposed on the screen by selecting that page in Teletext mode. Find the appropriate page number from the Teletext Index page. Enter the number and once the page has been found, you will see the normal TV programme with the subtitles superimposed on it.

To erase the subtitles, press twice the key .

### NEWS FLASH

The latest news can be superimposed on the television picture. Look up the teletext index to find the page number and enter it. Once the page has been found, you can watch the normal television programme. When the latest news page is updated it will be superimposed on the picture.

The remote control can be used for sound and picture settings again. If you switch to another station, the «Latest news» function is disabled.

If after having seen these news you wish to remove the display from the screen, press the blue key .



followed by the key .

# television set manual programming

You may use this channel adjustment menu if you do not wish to restart auto programming (where there are only few channels in your area or if a new channel is transmitting).

## PROGRAMME

The following menu is displayed:  
TUNING is selected

If this is not the case, select the contents line using the yellow key  and TUNING with the key .

If the menu is not in English, refer to the *INSTALLATION* chapter, page 10.

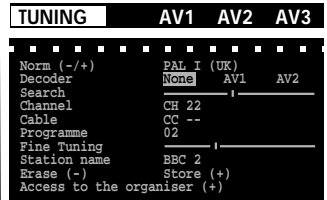

## Norm

Select the Norm (-/+) line (yellow key).

Select the broadcasting standard :

- PAL/SECAM BG (Euro) : Western Europe (BG)
- FRANCE L L' : France and Luxembourg (LL')
- PAL BG+ : Special standards (Switzerland)
- SECAM DKK' : Eastern Europe, Middle East (DKK')
- PAL I (UK) : United Kingdom, Ireland (I)

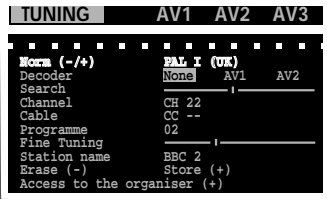
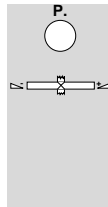

## Decoder

This function allows you to access programmes using the PR +/- keys (zapping).

Select Decoder line (yellow key).

Select one of the options :

- None** = no decoder
- AV1** = Decoder connected to Euro-AV1 socket
- AV2** = Decoder connected to Euro-AV2 socket.

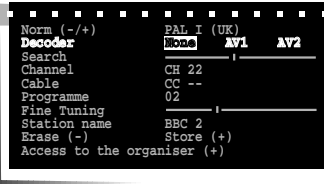
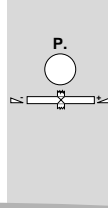

## Channel / Cable

If you do not know the channel numbers.

Select the Search line (yellow key).

Start the search by pressing :

- + : for forward channel search
- : for backward channel search.

The cursor indicates the part of the range in which it is performing the search.

The channel numbers are displayed on

- Channel line when received via an aerial or
- Cable line for cable networks.

Once a station has been received, the picture appears on the screen. If the picture, corresponds to the station required, go to the Programme line, otherwise continue the search, with (+).

If you already know the channel numbers.

Select the line

- Channel for TV channels (aerial) or
- Cable for cable networks.

Enter the channel number (it must have 2 digits)  
e.g. : for channel 6, enter 0 and then 6.

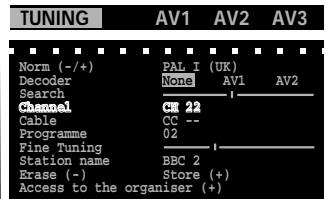
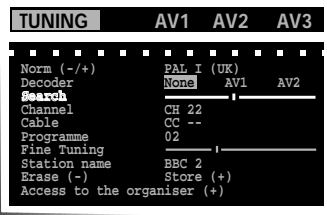
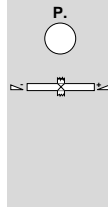

# television set manual programming



## Programme

Select the **Programme** line (yellow key).

Enter the station number.

### Programme 1 to 9 :

Press the corresponding digit briefly (eg: 03, press 3).

### Programme 10 to 99 (eg : 52) :

Briefly press 5 to display the tens : **5 -**

Briefly press 2 to display the units : **5 2**

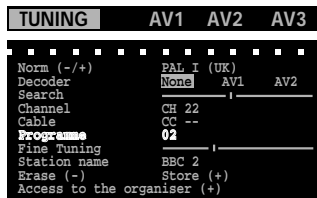
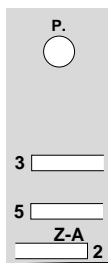

Optional :

To be used if the picture is not clear or for searching for a specific source, for example, a video recorder channel

## Fine Tuning

Select **Fine Tuning** line (yellow key).

+ : sharper picture contours or search higher in the range

- : softer picture contours or search lower in the range.

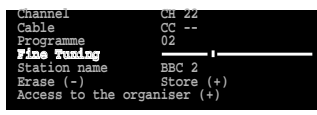
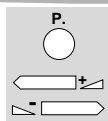

## Station name

Select the **Station name** line (yellow key).

The station name can be written in 6 characters.

Hold down the button : the characters are displayed in ascending order.

Hold down the button : the characters are displayed in the descending order.

When the required character appears, press these buttons to go the next or previous character.

**!** To leave a space look for the blank character (between ? and A).

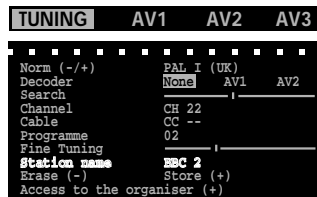
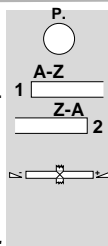

## Erase / Store

Press yellow key to select **Erase (-) Store (+)** line.

Briefly press, your channel is stored in the memory.

If you wish to **Erase**, press

**!** Continue the search for a different station.

**!** Search and store all the stations by repeating the above procedure starting from **Search**, **Channel** or **Cable**.

**!** Repeat the process for the next programme/station starting from **NORM**.

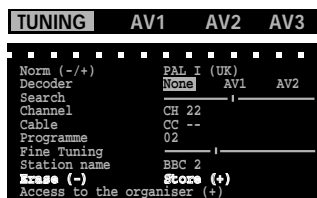
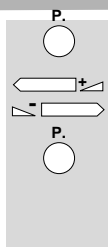

## Access to the organiser

When all the channels or the new channel have been retrieved, you can access the channels management menu.

Select the line **Access to the organiser** (yellow key)

The menu **Programme Organiser** appears.

Proceed as explained on page 7 to list the channels in the order required by you and to give them a name if this has not already been done.

To return to the **TUNING** menu

press once on the key .

To clear the menus

press twice on the key .

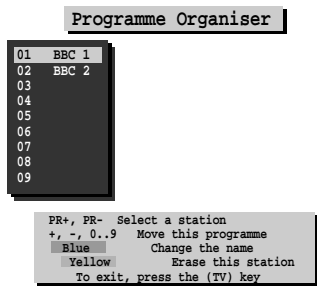
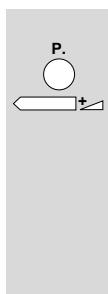

**!** *Nous vous recommandons de découper cette vignette pour qu'un enfant ne puisse pas en prendre connaissance.*

## **SI VOUS NE VOUS SOUVEZ PLUS DE VOTRE CODE PERSONNEL**

Appuyez sur la touche jaune pour sélectionner la ligne **Sommaire** du menu, puis sur la touche (+) pour sélectionner **VERROUILLAGE**.

Appuyez sur la touche jaune pour sélectionner la ligne **Entrer votre numéro de code**. Appuyez simultanément sur les touches **PR+** et **PR-** du téléviseur.

L'ancien code se trouve alors effacé et vous pouvez en entrer un nouveau. Après le changement de code, il n'est pas nécessaire de reverrouiller les programmes qui étaient verrouillés.

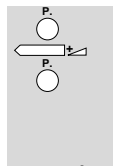

**!** *Recomendamos cortar este cupón para que los niños no tengan acceso al mismo.*

## **SI SE OLVIDO EL CÓDIGO PERSONAL**

Pulse la tecla amarilla para seleccionar la línea **Índice** del menú, luego la tecla (+) para seleccionar **BLOQUEO**.

Pulse la tecla amarilla para seleccionar la línea **Introducir el número del código**. Pulsar simultáneamente las teclas **PR+** y **PR-** del televisor.

El código antiguo se borra, pudiéndose introducir otro nuevo. Después de un cambio de código, no es necesario volver a proteger los programas que ya estaban protegidos.

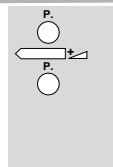

**!** *We recommend you cut out this sticker to keep it hidden from the children.*

## **IF YOU NO LONGER REMEMBER YOUR PERSONAL CODE**

Press the yellow button to select the menu **Contents** line, then the (+) button to select **LOCK**.

Press the yellow button to select the line **Enter your PIN number**. Press simultaneously the **PR+** and **PR-** buttons on the TV.

The old code is then erased and you may enter a new one. After changing code, it is not necessary to relock the programs which were already locked.

