

Dell™ E770p Color Monitor

Quick Setup Guide



Safety Instructions

Observe the following safety guidelines when connecting and using your monitor:

- Be sure your monitor is electrically rated to operate with the AC power available in your location.
- Locate your monitor near an easily accessible electrical outlet.
- Place the monitor on a solid surface and treat it carefully. The screen can be damaged if dropped, sharply hit, or touched with a sharp or abrasive implement.
- Put your monitor in a location with low humidity and a minimum of dust.
- Never use your monitor if the power cable has been damaged. Do not allow anything to rest on the power cable, and keep the cable away from where people could trip over it.
- Never insert anything metallic into the monitor openings. Doing so may create the danger of electric shock.
- To avoid electric shock, never touch the inside of the monitor. Only a qualified technician should open the monitor's case.
- Be sure to hold the plug, not the cable, when disconnecting the monitor from an electrical outlet.
- Openings in the monitor cabinet are provided for ventilation. To prevent overheating, these openings should not be blocked or covered. Also, avoid using the monitor on a bed, sofa, rug, or other soft surface. Doing so may block the ventilation openings in the bottom of the cabinet. If you put the monitor in a bookcase or some other enclosed space, be sure to provide adequate ventilation.
- Do not expose the monitor to rain or use it near water. If the monitor accidentally gets wet, unplug it and contact an authorized dealer immediately. You can clean the exterior of the monitor with a damp cloth when necessary, but be sure to unplug the monitor first.
- If your monitor does not operate normally—in particular, if there are any unusual sounds or smells coming from it—unplug the monitor immediately and contact an authorized dealer or service center.



Connecting Your Monitor to a Computer

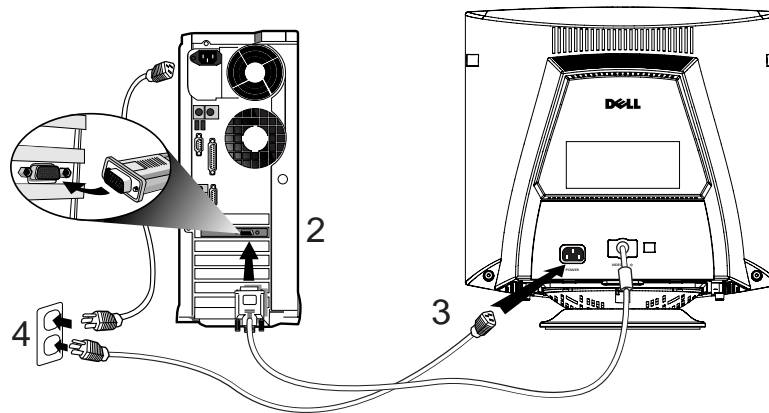

1. Turn off your computer and unplug your computer's power cable.
2. Connect the blue connector of the monitor's signal cable to the blue video connector on the back of your computer. Tighten the connector screws finger-tight. Do not overtighten.
3. Fully insert the monitor power cable into the power port on the back of the monitor.
4. Plug the power cables of your computer and your monitor into a nearby electrical outlet.
5. Turn on your computer and monitor. If the monitor does not display an image, refer to the troubleshooting section of this guide.



Monitor Controls and Indicators

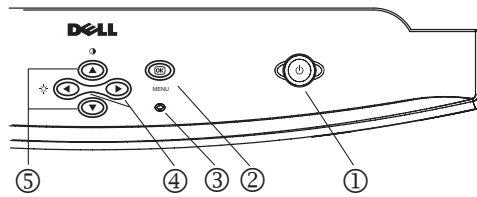

1. Power button - Switches your monitor on.
2. "OK" button - When pressed it will take you to the OSD controls.
3. Power Indicator - This light glows green during normal operation.
4. Brightness hotkeys - Pressing either Left or Right arrow directly will adjust screen brightness (BRIGHTNESS control bar will appear on screen).
LEFT and RIGHT buttons - These are also used for adjusting other functions in the Main OSD Menu of your monitor.
5. Contrast hotkeys - Pressing either Up or Down arrow directly will adjust screen contrast (CONTRAST control bar will appear on screen).
UP and DOWN buttons - These are also used for selecting other functions in the Main OSD Menu of your monitor.



Driver Installation

Use the monitor CD to install the appropriate monitor driver for your operating system.

Microsoft® Windows® 98 Operating System

Windows 98 automatically detects the new monitor and displays the **Add New Hardware Wizard** dialog box if the monitor driver is not already installed.

1. Insert the monitor CD into the CD-ROM drive, and click **Next>** twice when the **Add New Hardware Wizard** dialog box appears.
2. Click the **CD-ROM drive** box to install the drivers from the CD and then click **Next>**.
3. Confirm that the driver was found on the CD, and click **Next>** twice to install the driver.
4. Click **Finish** to exit the **Add New Hardware Wizard** dialog box.

To manually install or update the driver, perform the following steps:

1. Click **Start**—> **Settings**—> **Control Panel** and then double-click **Display**.
2. In the **Display Properties** window, click the **Settings** tab, and then click **Advanced**.
3. Click the **Monitor** tab, and then click **Change**.
4. When the **Update Device Driver Wizard** dialog box appears, follow the steps in the previous paragraph.

Microsoft Windows 95 Operating System

First determine the Windows 95 version installed on your computer by right-clicking the **My Computer** icon on the desktop and selecting **Properties**. The version number is listed under **System**. Perform the steps for the appropriate version.

Version 4.00.950A

1. Click **Start**—> **Settings**—> **Control Panel** and then double-click **Display**.
2. In the **Display Properties** window, click the **Settings** tab and then click **Change Display Type**.
3. In the **Change Display Type** window, click **Change** and then click **Have Disk**.
4. Insert the monitor CD into the CD-ROM drive, type d:\ (change the drive letter to match your CD-ROM drive if it is not drive D) in the **Copy manufacturer's files from:** box, and click **OK**.
5. In the **Select Device** window, click the appropriate monitor model and then click **OK**.
6. In the **Change Display Type** window, click **Close**.
7. In the **Display Properties** window, click **OK**.

Version 4.00.950B

1. Click **Start**—> **Settings**—> **Control Panel** and then double-click **Display**.
2. In the **Display Properties** window, click the **Settings** tab and then click **Advanced Properties**.
3. In the **Advanced Display Properties** window, click the **Monitor** tab and then click **Change**.
4. In the **Select Device** window, click **Have Disk**.
5. Insert the monitor CD into the CD-ROM drive, type d:\ (change the drive letter to match your CD-ROM drive if it is not drive D) in the **Copy manufacturer's files from:** box, and click **OK**.
6. In the **Select Device** window, click the appropriate monitor model and then click **OK**.
7. In the **Advanced Display Properties** window, click **Close**.
8. In the **Display Properties** window, click **OK**.



Accessing the User's Guide Online or via CD

To view the latest monitor *User's Guide*, access the SUPPORT section of the Dell Web site (<http://support.dell.com>).

If you do not have Internet access, you can access the guide on the monitor CD:

1. Insert the monitor CD into your CD-ROM drive.
A start-up document should launch automatically; however, if the start-up document does not launch automatically, click **Start**—> **Run**, type `D:\monitor.htm`, and click **OK**. (Substitute the correct CD-ROM drive letter if it is not the D drive.)
2. Click the appropriate icon to open the *User's Guide* in the desired language.



NOTE: All applicable warranty and regulatory information regarding your monitor is contained in the User's Guide on your CD.



Troubleshooting Tips

Monitor Has No Power

If the monitor's power indicator is off and no image appears on the display, perform the following checks:

- Ensure that the power cable is fully inserted in the monitor's power port and the electrical outlet.
- Test the electrical outlet by plugging in a working electrical device such as a lamp.
- Ensure that the power button has been depressed, and wait for the power indicator to light.
- Try another power cable on the monitor. Use the computer's power cable and turn on the monitor with the signal cable disconnected. If the monitor is working correctly, a self-test pattern appears.

No Image Is Displayed on the Monitor

If the monitor power indicator is on but no image appears on the display, perform the following checks:

- Ensure that the video connector is seated properly. Tighten the connector screws securely with your fingers.
- Ensure that the computer is on.
- Increase brightness and contrast controls.
- Turn off the monitor and unplug the signal cable. Check the cable connector for bent or broken pins.
- With the signal cable still disconnected, turn on the monitor. If the monitor is working correctly, a self-test pattern appears.
- Perform a monitor reset or recall.

IMPORTANT!

Before contacting Dell for technical assistance, refer to the Troubleshooting section in the *User's Guide* on your monitor CD. This section contains detailed information for resolving most monitor problems.

Information in this document is subject to change without notice.
© 1999 Dell Computer Corporation. All rights reserved.

Reproduction in any manner whatsoever without the written permission of Dell Computer Corporation is strictly forbidden.

Trademarks used in this text: *Dell* and the *DELL* logo are trademarks of Dell Computer Corporation; *Microsoft* and *Windows* are registered trademarks of Microsoft Corporation.

Other trademarks and trade names may be used in this document to refer to either the entities claiming the marks and names or their products. Dell Computer Corporation disclaims any proprietary interest in trademarks and trade names other than its own.