

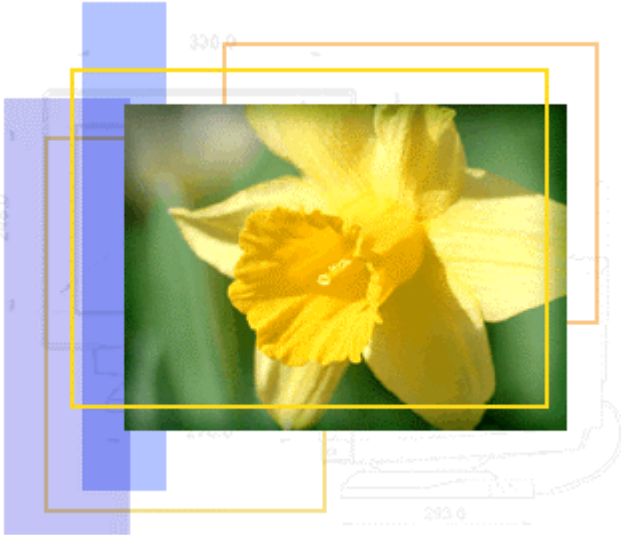

# U s e r ' s M a n u a l

## PV720A



## Table of Contents

1.	<a href="#"><u>Important Safety Instructions</u></a>	3
2.	<a href="#"><u>Introduction</u></a>	8
3.	<a href="#"><u>Recommended Use of the Monitor</u></a>	14
4.	<a href="#"><u>Controls and Adjustments</u></a>	16
5.	<a href="#"><u>Energy Declaration</u></a>	24
6.	<a href="#"><u>Trouble Shooting</u></a>	25
7.	<a href="#"><u>Technical Information</u></a>	27
8.	<a href="#"><u>Product Overview</u></a>	29
9.	<a href="#"><u>Specifications</u></a>	31

## Important Safety Instructions

### FCC Statement

This equipment has been tested to comply with the limits for a class B digital device, pursuant to Part 15 of the FCC rules. These limits are designed to provide reasonable protection against harmful interference in a residential installation. This equipment generates, uses and can radiate radio frequency energy and, if not installed and used in accordance with the instructions, may cause harmful interference to radio communications. However, there is no guarantee that interference will not occur in a particular installation. If this equipment does cause harmful interference to radio or television reception, which can be determined by turning the equipment off and on, the user is encouraged to try to correct the interference by one or more of the following measures:

- Relocate the receiving antenna.
- Increase the separation between the equipment and the receiver.
- Connect the equipment into an outlet on a circuit different from that to which the receiver is connected.
- Consult the dealer or an experienced radio/TV technician for help.

### Warning:

If a shielded-type power cord is supplied with this monitor, it is required in order to meet FCC emission limits and to prevent interference with nearby radio and television reception. Only shielded cables should be used to connect I/O devices to this equipment. You are cautioned that changes or modifications not expressly approved by the party responsible for compliance could void your authority to operate the equipment.

### CE Statement

This device complies with the requirements of EMC (Electromagnetic Compatibility), and with Low Voltage directive.

## TCO'99

**T**CO99 compliant monitors must be compliant with TCO99 which is more stringent than MPRII. The purchase of TCO99 compliant monitors contributes to reducing the burden on the environment and also to the further development of environmentally adapted electronics products.

### **Why do we have environmentally labelled computers?**

In many countries, environmental labelling has become an established method-for encouraging the adaptation of goods and services to the environment. The main problem, as far as computers and other electronics equipment are concerned, is that environmentally harmful substances are used both in the products and during their manufacture. Since it is not so far possible to satisfactorily recycle the majority of electronics equipment, most of these potentially damaging substances sooner or later enter nature.

There are also other characteristics of a computer, such as energy consumption levels, that are important from the viewpoints of both the work (internal) and natural (external) environments. Since all methods of electricity generation have a negative effect on the environment (e.g. acidic and climate-influencing emissions, radioactive waste), it is vital to save energy. Electronics equipment in offices is often left running continuously and thereby consumes a lot of energy.

What does labelling involve?

This product meets the requirements for the TCO'99 scheme which provides for international and environmental labelling of personal computers. The labelling scheme was developed as a joint effort by the TCO (The Swedish Confederation of Professional Employees), Svenska Naturskyddsforeningen (The Swedish Society for Nature Conservation) and Statens Energimyndighet (The Swedish National Energy Administration).

Approval requirements cover a wide range of issues: environment, ergonomics, usability, emission of electric and magnetic fields, energy consumption and electrical and fire safety.

The environmental demands impose restrictions on the presence and use of heavy metals, brominated and chlorinated flame retardants, CFCs (freons) and chlorinated solvents, among other things. The product must be prepared for recycling and the manufacturer is obliged to have an environmental policy which must be adhered to in each country where the company implements its operational policy.

The energy requirements include a demand that the computer and/or display, after a certain period of inactivity, shall reduce its power consumption to a lower level in one or more stages. The length of time to reactivate the computer shall be reasonable for the user.

Labelled products must meet strict environmental demands, for example, in respect of the reduction of electric and magnetic fields, physical and visual ergonomics and good usability. Below you will find a brief summary of the environmental requirements met by this product. The complete environmental criteria document may be ordered from:

TCO Development

SE-114 94 Stockholm, Sweden

Fax: +46 8 782 92 07

Email (Internet): [development@tco.se](mailto:development@tco.se)

Current information regarding TCO'99 approved and labelled products may also be obtained via the Internet, using the address: <http://www.tco-info.com/>

## **Environmental requirements**

### **Flame retardants**

Flame retardants are present in printed circuit boards, cables, wires, casings and housings. Their purpose is to prevent, or at least to delay the spread of fire. Up to 30% of the plastic in a computer casing can consist of flame retardant substances. Most flame retardants contain bromine or chlorine, and those flame retardants are chemically related to another group of environmental toxins, PCBs. Both the flame retardants containing bromine or chlorine and the PCBs are suspected of giving rise to severe health effects, including reproductive damage in fish-eating birds and mammals, due to the bio-accumulative\* processes. Flame retardants have been found in human blood and researchers fear that disturbances in foetus development may occur.

The relevant TCO'99 demand requires that plastic components weighing more than 25 grams must not contain flame retardants with organically bound bromine or chlorine. Flame retardants are allowed in the printed circuit boards since no substitutes are available.

**Cadmium\*\***

Cadmium is present in rechargeable batteries and in the colour-generating layers of certain computer displays. Cadmium damages the nervous system and is toxic in high doses. The relevant TCO'99 requirement states that batteries, the colour-generating layers of display screens and the electrical or electronics components must not contain any cadmium.

**Mercury\*\***

Mercury is sometimes found in batteries, relays and switches. It damages the nervous system and is toxic in high doses. The relevant TCO'99 requirement states that batteries may not contain any mercury. It also demands that mercury is not present in any of the electrical or electronics components associated with the labelled unit.

**CFCs (freons)**

The relevant TCO'99 requirement states that neither CFCs nor HCFCs may be used during the manufacture and assembly of the product. CFCs (freons) are sometimes used for washing printed circuit boards. CFCs break down ozone and thereby damage the ozone layer in the stratosphere, causing increased reception on earth of ultraviolet light with e.g. increased risks of skin cancer (malignant melanoma) as a consequence.

**Lead\*\***

Lead can be found in picture tubes, display screens, solders and capacitors. Lead damages the nervous system and in higher doses, causes lead poisoning. The relevant TCO'99 requirement permits the inclusion of lead since no replacement has yet been developed.

\*Bio-accumulative is defined as substances which accumulate within living organisms.

\*\* Lead, Cadmium and Mercury are heavy metals which are Bio-accumulative.

**Safety Precautions**

Please read the following instructions carefully. This manual should be retained for future reference.

1. To clean the LCD Monitor screen make sure the Monitor is in the power off mode. Unplug the Monitor from its power source before cleaning it. Stand away from the LCD Monitor and spray cleaning solution onto a rag. Without applying excessive pressure clean the screen with the slightly dampened rag.

2. Do not place your LCD Monitor near a window. Exposing the Monitor to rain, water, moisture or sunlight can severely damage it.

3. Do not place anything on top of the Monitor/PC signal cord. Make sure the cord is placed in an area where it will not be stepped on.

4. Do not apply pressure to the LCD screen. Excessive pressure may cause permanent damage to the display.

5. Do not remove the cover or attempt to service this unit by yourself. You may void the warranty. Servicing of any nature should only be performed by an authorised technician.

6. Safe storage of the LCD Monitor is in a range of minus 20 to plus 65 degrees Celsius. Storing your LCD Monitor outside this range could result in permanent damage.

7. If any of the following occurs immediately unplug your Monitor and call an authorized technician.

- The power or Monitor-to-PC signal cord is frayed or damaged.
- Liquid has been spilled into the Monitor, or it has been exposed to rain.
- The Monitor has been dropped or the case has been damaged.

8. For use only with power supply:

- FSP Electronic Co., Ltd. Type: FSP040-1AD101
- Linearity Electronic Co., Ltd. Type: LAD6019AB4
- Li shin International Enterprise Corp. Type: LSE9901B1250
- LIEN CHANG Corp. Type LA-40M-112

**Notice : Actual safety specifications please refer to the label on the back of monitor.**

## Introduction

### Product Description

Congratulations on purchasing this new generation monitor. Your LCD monitor incorporates high quality display into a small lightweight module. It has power- saving capabilities and emits no X-ray radiation.

The features are:

- 17" TFT Liquid Crystal Display
- Compatible with IBM VGA, VESA
- Direct RGB input
- SXGA 1280x1024 resolution
- Lightweight compact design, weighing less than 7.5Kg
- DPMS (power saving)
- Universal adapter power supply
- Anti-glare display
- On-Screen Display (OSD) controls and adjustments

### Package Overview

Your monitor package contains:



LCD Monitor





User's Guide /  
Driver CD



Power Cord



Power Adapter



D-Sub 15 VGA Signal Cable



3.5 mm Audio Cable



Speaker Box

**CAUTION**

*Keep the shipping carton in case the need arises to store or transport the unit. Let the LCD lie on its face when you put it into the carton.*

## Installation & Remove

### 1-1. Installing the Portrait

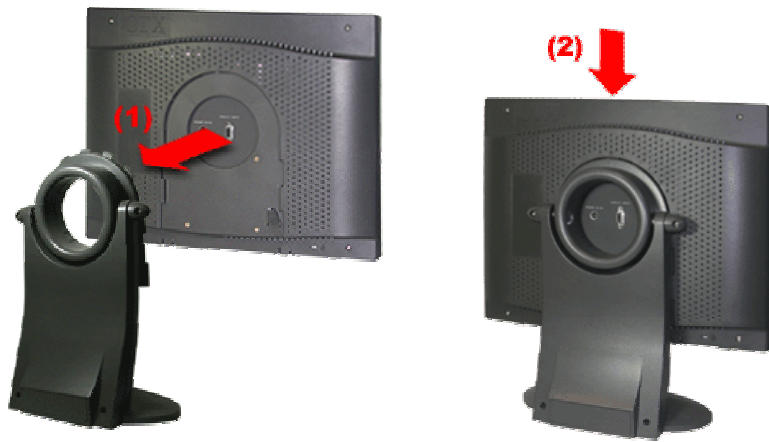

### 1-2. Remove the Portrait



2-1. Rotating to the mode "Portrait" (vertical orientation)

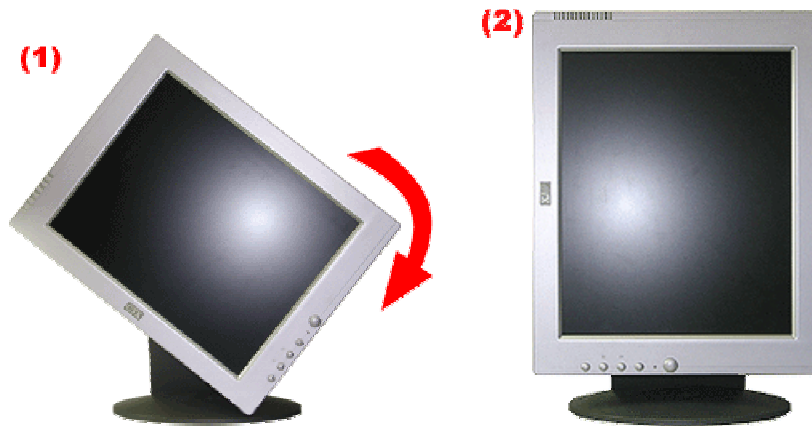

3-1. Installing VESA-compliant Connecting Device\*

This product provides square screw holes that conform to 100mm\*100mm VESA-compliant connection interface.



3-2. Remove VESA-compliant Connecting Device\*



\*User should prepare the connection device for VESA themselves.

4-1. Speaker Box Install



**Cabling for Your Display**

1. Turn off the power of your computer and other devices.
2. Connect (1) the video signal cable of the monitor to the 15-pin connector of the video port in your computer.
3. With the monitor switched off, attach (2) the power cord to the monitor and then to a grounded power outlet.

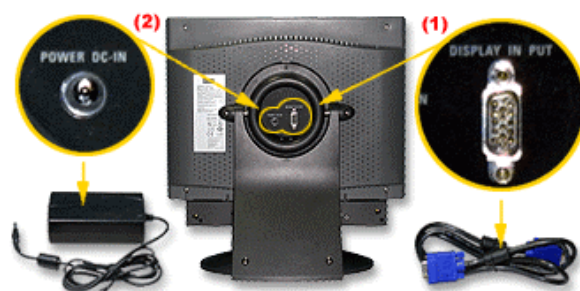

4. Connect your audio cable one end to the external speaker, through the connector of audio input on the rear part; the other end to audio device (such like connector of the sound card in the PC).



5. Connect to the earphone plug-in if you need this device.

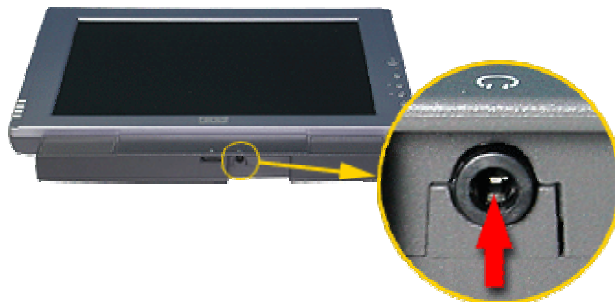

6. Turn on the monitor and computer.
7. If necessary, adjust the front panel controls according to your personal preference.

## Recommended Use of the Monitor

### Power

Use the type of power indicated on the marking label.

### Plugs

Do not remove any of the prongs of the monitor's three-pronged power plug.

Disconnect the power plug from the AC outlet if you are not going to use it for an indefinite period of time.

### Power cords

Use the proper power cord with correct attachment plug type. If the power source is 120 V AC, use a power cord that has UL and CSA approvals. If the power source is a 240 V AC supply, use the tandem (T blade) type attachment plug with ground conductor power cord that meets the respective European country's safety regulations, such as VDE for Germany.

We recommend using the power cord supplied with the product. However, if another type of power cord is required power cord H05VV-F or VW-1, 18AWG x 3G should be used.

Do not overload wall outlets or power cords. Ensure that the total of all units plugged into the wall outlet does not exceed 7 amperes.

Ensure that the total ampere ratings on all units plugged into the extension cord is not above the cord's rating.

If the power supply cord which came with your monitor is to be connected to the PC instead of the wall outlet, this equipment should be used with UL/TUV approved computers with receptacle rated 100~240V AC, 50/60Hz, 1.0A (minimum).

Do not allow anything to rest on the power cord. Do not locate this product where persons will walk on the cord.

## **Environment**

Place the monitor on a flat level surface.

Place the monitor in a well-ventilated place.

Keep the monitor away from: rain or water overly hot, cold or humid places  
sunlight dusty surroundings equipment that generates strong magnetic fields.

## Controls and Adjustments

Once you have installed this monitor with your system, please read the instructions in this section, they give you some guidelines on how to use the monitor more efficiently. And lead you through the various functions of the user controls and explain how to adjust the monitor to your personal preference.

### Front User Controls

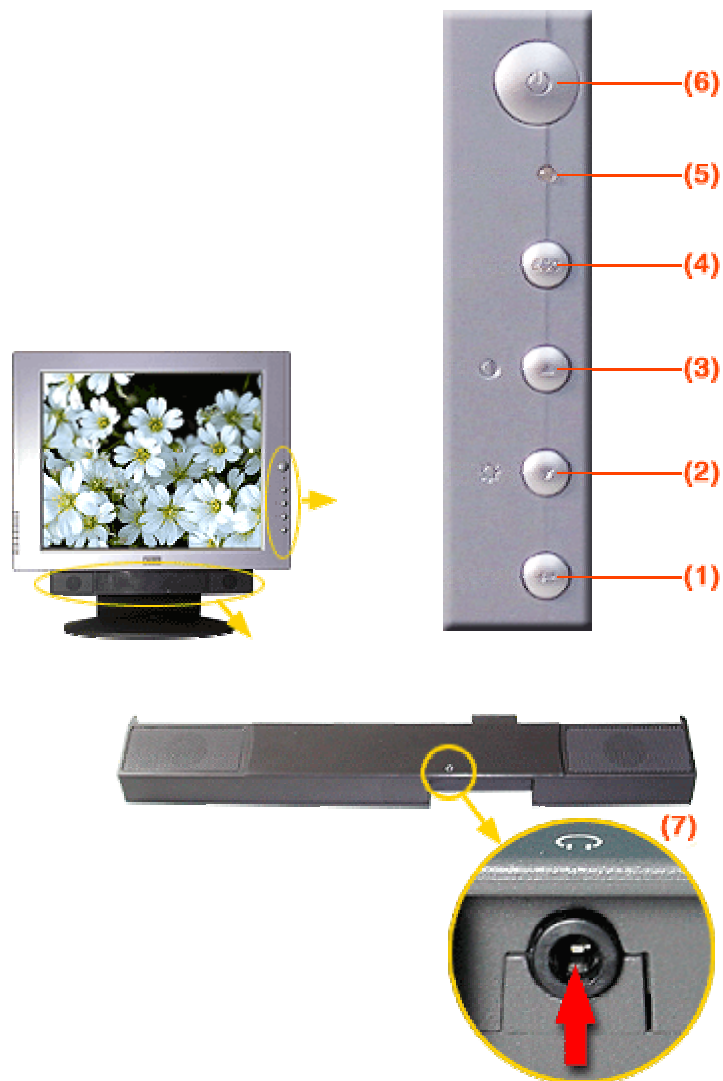



**(1) Enter "↵" button**

To display the OSD manual and select functions.

**(2) Down "▼" button**

To adjust the selected OSD function or the brightness directly.

**(3) Up "▲" button**

To adjust the selected OSD function or the contrast directly.

**(4) "ESC" button**

To close the OSD manual and to escape function.

**(5) Power LED Indicator**

As long as the monitor is powered, this indicator is lit. In normal operation, it lights green. While in power saving mode, the indicator will turn to amber.

**(6) Power Switch**

To turn the monitor On or Off.

**(7) Stereo Earphone Plug-in (Bottom View)**

**(8) Audio Connector (Back View)**



## On Screen Display (OSD) Main menu

1. Press "←" to open the OSD main menu.
2. Use the "▲" and "▼" arrows to move through the displayed functions.
3. Press "←" to confirm your selected function.

### Brightness

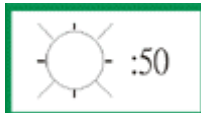

Press the "▼" button to enter the brightness, and press the "▲" or "▼" button to increase or decrease the brightness level, then press "ESC" button to exit.

### Contrast



Press the "▲" button to enter the contrast, and press the "▲" or "▼" button to increase or decrease the contrast level, then press "ESC" button to exit.

## 1. Volume Tuning

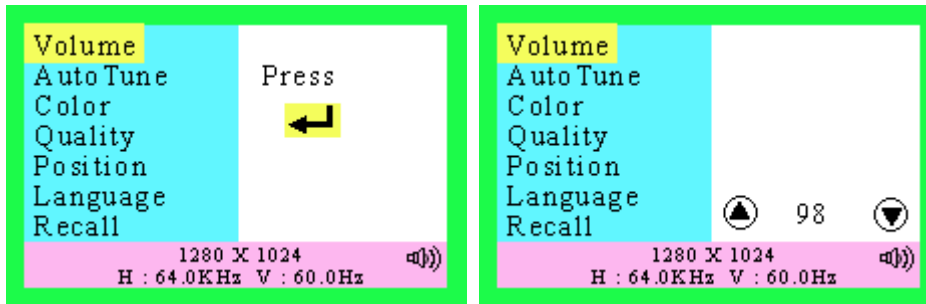

- **Normal Mode**

Press "←" to enter "Volume", and press "▲" or "▼" to adjust the volume.

- **Power Saving Mode (when power indication lights amber)**

a. Mute Hot Key (when playing music)

Press "ESC" to enter Mute Mode, and press "ESC" again will return to sound playing mode.

b. Control the volume

In Power Saving Mode, press "▲" or "▼" to enter the volume tuning window, and press "▲" or "▼" key to adjust the volume. After 6 seconds, the volume tuning window will close automatically.

## 2. Auto Tune

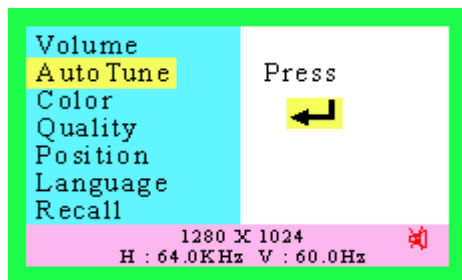

Press "←" button, the system will automatically adjust the clock, phase, H-position and V-position values for optimal settings.

### ADVANCE AUTO TUNE PATTERN PROGRAM USING GUIDE

- As some VGA Card doesn't match the VESA standard. It can't out-put 0.7 V p-p VESA standard. Therefore, we need "ADVANCE AUTO TUNE PATTERN PROGRAM" to modify the parameters of monitor to match different output level of VGA card.
- Win\_pat.exe (This file includes in the folder "driver" of CD Title "Interactive User's Manual") is used for Windows95 or 98 currently display mode adjustment. It will adjust the VGA input level and video quality to optimize.
- Dos\_pat.exe (This file includes in the folder "driver" of CD Title "Interactive User's Manual") is used for 720x400 70Hz & 640x 350 70Hz under DOS mode adjustment. It will adjust the VGA input level and video quality to optimize.
- For the adjustment, please execute the program, then processing the "Auto Tune" function in the OSD menu.

### 3. Color

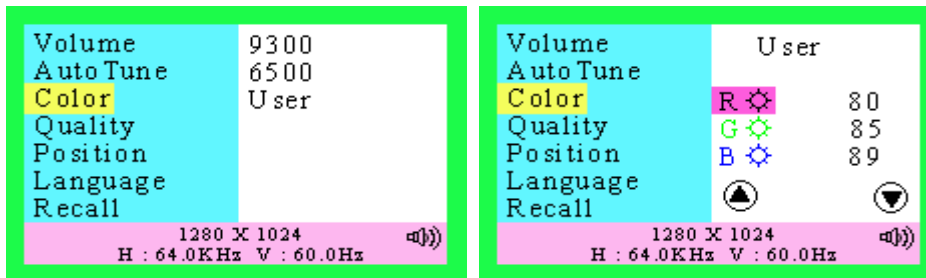

You can choose either the 6500°K, 9300°K colour temperature mode or User mode to store your user defined color settings.

#### User Mode

- Press "←" button to enter User mode.
- Press the "▲" or "▼" button to select the R/G/B gain, then press "←" button to proceed.
- Finally, press "ESC" button to leave this function.

### 4. Quality

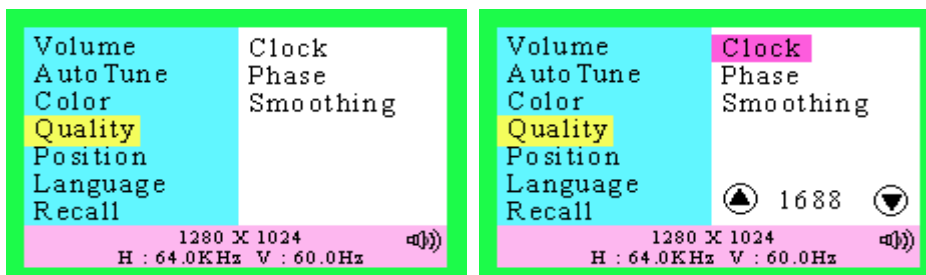

Here are some items can be adjusted as below, please press "←" enter the item menu.

- **Clock:**  
Press the "▲" or "▼" button to adjust the width of the screen to a maximum.
- **Phase:**  
Press the "▲" or "▼" button to reduce the noise on the screen.
- **Smoothing:**  
Press the "▲" or "▼" button to select "Yes" or "No" to enable "smoothing".

## 5. Position

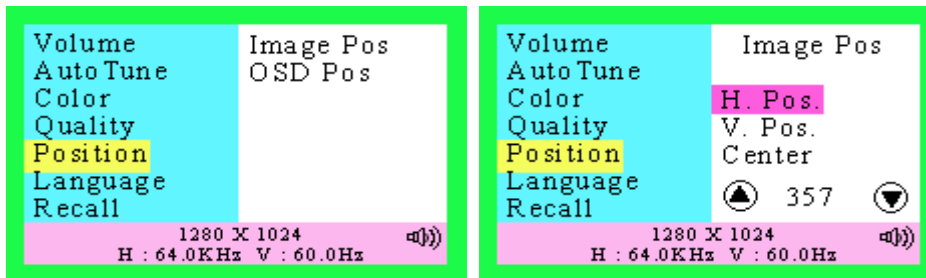

To adjust the Image or OSD position.

### Image Position or OSD Position

- **H - Position:** Press the "▲" or "▼" button to reposition of the picture or the OSD window to the right or left.
- **V - Position:** Press the "▲" button to moves the picture or the OSD window upwards and "▼" to move them downwards.
- **Center:** The Image or OSD window will be adjusted automatically on center of the screen.

## 6. Language

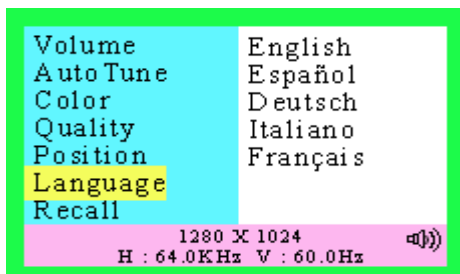

Press the "▲" or "▼" button to select between English, French, Italian, Spanish or German languages.

## 7. Recall

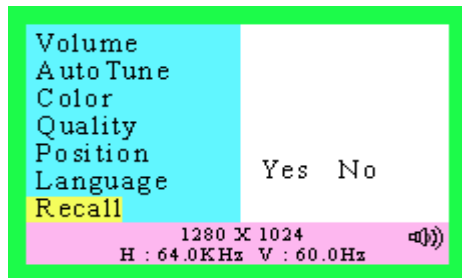

Press the "▲" or "▼" button to select "Yes" or "No".

Choosing Recall to callback all the settings for the current Input Signal mode to factory preset.

## Energy Declaration

This monitor is equipped with a function for saving energy, which supports the VESA Display Power Management Signaling (DPMS) standard. This means that the monitor must be connected to a computer, which also supports the VESA DPMS standard to fulfill the requirements of the NUTEK specification 803299/94/96. The time settings for switching to a power saving mode are adjusted from the system unit by software. From the first indication of inactivity to power saving position A2 the total time must not be set to more than 70 minutes.

### 1. VESA Power-Management Proposal

#### VESA DPMS Standard

H. sync	V. sync	Video	State
Off	On	Blank	Stand-by
On	Off	Blank	Suspend
Off	Off	Blank	Off

### 2. Power Consumption (120/230 Vac) (Without Audio)

NUTEK	VESA state	LED indicator	Power Consumption
Normal operation	On	Green	< 40W
Power Saving Position A1	Suspend	Amber	≤ 5W
Power Saving Position A2	Off	Amber	≤ 5W



## Trouble Shooting

If you are experiencing trouble with the LCD display refer to the following. If the problem persists please contact your local dealer or our service center.

<p><b>The monitor does not respond after you turn on the system.</b></p>	<p>Check if the monitor is turned on.</p> <p>Turn off the power and check the monitor power cord and signal cable are properly connected.</p>
<p><b>The characters on the screen are dim.</b></p>	<p>Refer to the Controls and Adjustments section to adjust the brightness (BRIGHTNESS on the OSD sub-menu.) .</p>
<p><b>The screen is blank.</b></p>	<p>During use the monitor screen may automatically turn off as a result of the Power Saving feature. Press any key to see if the screen comes back.</p> <p>Refer to the Controls and Adjustments section to adjust the brightness (BRIGHTNESS on the OSD sub-menu.) .</p>
<p><b>The screen flashes when it initializes.</b></p>	<p>Turn off the monitor and turn it on again.</p> <p>Refer to the Controls and Adjustments section to reload the default setting (RESET on the OSD main-menu.) .</p>
<p><b>Partial image or incorrectly displayed image</b></p>	<p>Check to see if the resolution of your computer is higher than that of the LCD display.</p> <p>Reconfigure the resolution of your computer to make it less than or equal to 1280 x 1024.</p>

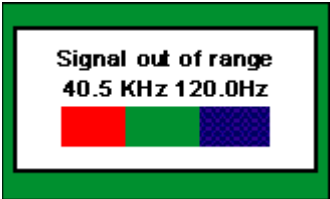
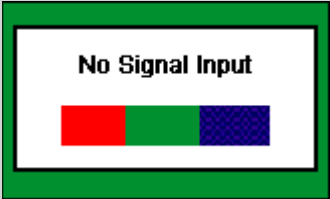
<p><b>Image has vertical line bars</b></p>	<p>Use "Clock" to make an adjustment.</p> <p>Check and reconfigure the display mode of the vertical refresh rate of your graphic card to make it compatible with the LCD display.</p>
<p><b>Image has horizontal flickering lines</b></p>	<p>Use "Phase" to make an adjustment.</p>
<p><b>Signal out of Range</b></p> 	<p>When the input signal is outside the normal specifications the screen will display an "Signal out of Range" message.</p>
<p><b>No Signal Input</b></p> 	<p>The "No Signal Input" message indicates that the cable may not be plugged property into the host system.</p>

**WARNING:**

*Do not disassemble the monitor. Contact your dealer if needed.*

## Technical Information

### Compatibility

This LCD monitor supports multiple operating platforms such as IBM compatible computers. This section provides you with detailed information on pin assignment of the D-Sub connector and the preset timing chart of the prevailing video standards.

### Pin Assignments

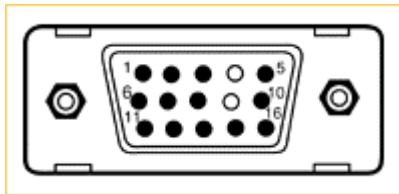

Male Mini D-15 Connector

Signal	15 Pin Mini D-Sub
Red Video	1
Green Video	2
Blue Video	3
Horizontal Sync	13
Vertical Sync	14
Ground	5, 6, 7, 8, 10, 11
No Connection	4, 9
SDA (DDC)	12
SCL (DDC)	15

## Video Modes

<b>Resolution</b>	<b>VCLK(MHz)</b>	<b>Horizontal Frequency (KHz)</b>	<b>Refresh Rate (Hz)</b>	<b>Standard</b>
640*350	25.175	31.470	70.000	IBM VGA
720*400	28.322	31.469	70.000	IBM VGA
640*480	25.175	31.470	59.940	IBM VGA
640*480	30.240	37.861	72.000	VESA
640*480	31.500	37.500	75.000	VESA
800*600	40.000	37.879	60.000	VESA
800*600	50.000	48.077	72.000	VESA
800*600	49.500	46.880	75.000	VESA
1024*768	65.000	48.363	60.000	VESA
1024*768	75.000	56.476	70.000	VESA
1024*768	78.750	60.020	75.000	VESA
1280*1024	108	63.981	60	VESA
1280*1024	135	79.976	75	VESA
1152*864	108	67.500	75	VESA

## Product Overview

### Pivot Function

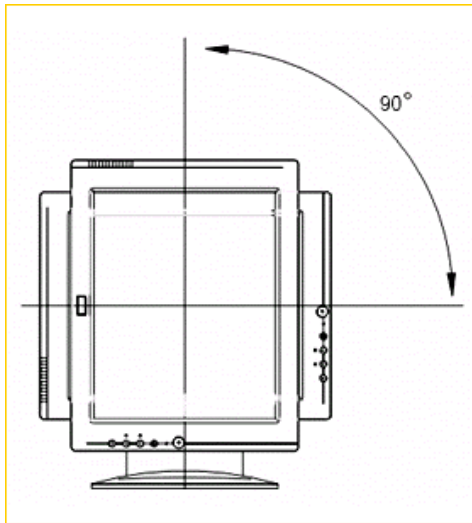

You can turn the LCD panel right 90 degree for particular viewing.

### Front View (unit: mm)

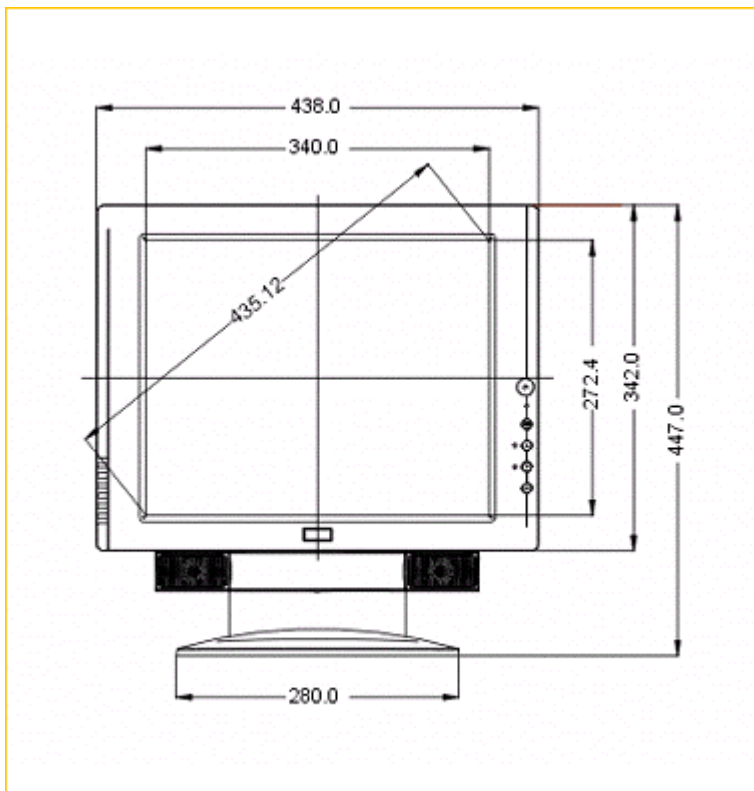

**Side View** (unit: mm)

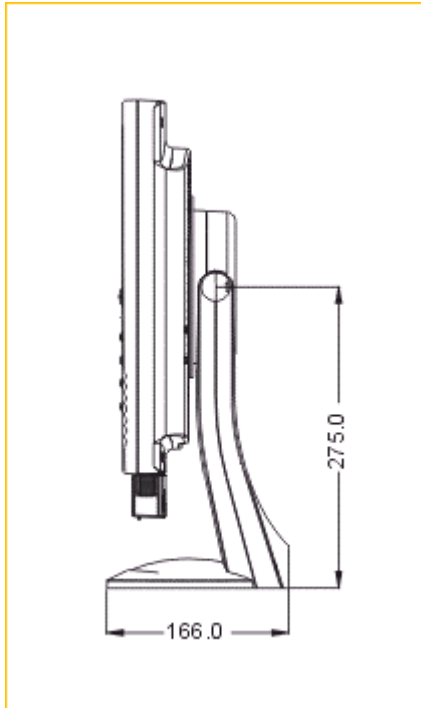

For viewing clarity, you can tilt the LCD panel forward (up to 5 degrees) or backward (up to 20 degrees)

**Rear View** (unit: mm)

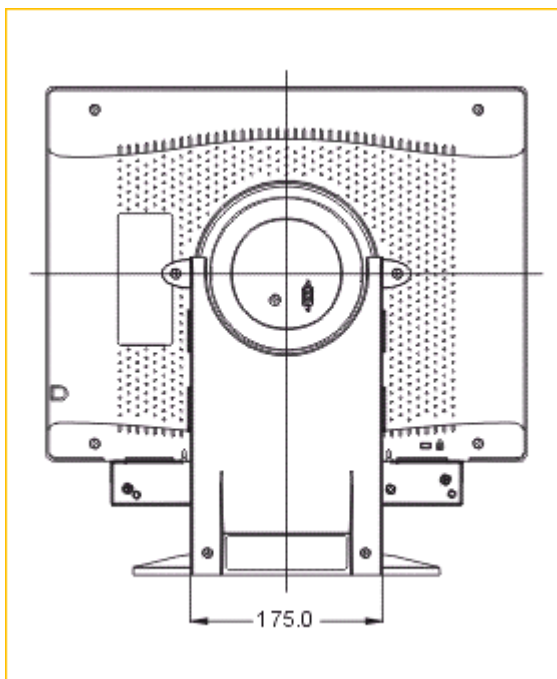

## Specifications

<b>LCD Panel</b>	17" TFT LCD module with wide-viewing angle, 0.264(H)x0.264 (V)mm pixel
------------------	---

### [ Monitor ]

<b>Effective display size</b>	17" (43.2 cm diagonal)
<b>Resolution (max.)</b>	SXGA 1280x1024
<b>Displayable colours</b>	16.7M True color
<b>Brightness</b>	250 Cd/m <sup>2</sup> (typical)
<b>Contrast ratio</b>	350:1 (typical)
<b>Scan Frequency</b>	Horizontal: 30 to 82 kHz automatically Vertical: 50 to 75 Hz automatically
<b>Response time</b>	45 ms
<b>Audio Input</b>	1V(RMS), Max.
<b>Audio Output</b>	1W X 2
<b>User controls</b>	Power/Enter/Up/Down/Esc
<b>Power Consumption</b>	40 W Max. ≤5 W Power Saving

### [ OSD control options ]

<b>Main menu</b>	Volume Tuning, Auto-Tune, Color, Quality, Position, Language, Recall
<b>Sub-menu</b>	Clock, Phase, Smoothing, Image Pos, OSD Pos

<b>Input signal</b>	Analog 0.7V peak to peak separate TTL Positive or Negative
---------------------	---

<b>Power Supply</b>	100~240 VAC, 50/60 Hz (automatically)
---------------------	---------------------------------------

<b>Plug &amp; Play</b>	DDC 1/2B
------------------------	----------

**[ Dimension & Weight ]**

<b>Size (WxDxH)</b>	438 x 166 x 447 mm
<b>Weight (net)</b>	7.5 Kgs

**[ Operating Environment ]**

<b>Temperature</b>	5°C ~ 35°C
<b>Humidity</b>	20% ~ 80% (non-condensing)
<b>Altitude</b>	10,000ft

**[ Storage Environment ]**

<b>Temperature</b>	-20°C ~ 60°C
<b>Humidity</b>	10% ~ 90% (non-condensing)
<b>Altitude</b>	40,000ft

*Note: Specifications are subject to change without notice*