

User's Guide

Compaq P710 Color Monitor
Compaq P910 Color Monitor
Compaq P1210 Color Monitor



CONTENTS

1. INTRODUCTION	
Features	1
Internal Preset Memory Capability	3
Power Management Function	3
DDC	3
Location Considerations	4
Cleaning Your Monitor	4
Unpacking	5
Tilt/Swivel Base	5
Screen Position Adjustment	5
Quick Operation Chart	5
2. PART NAME	
Control Names	1
3. INSTALLATION AND CONNECTION	
AC Power Connection	1
Signal Cable Connection	1
Connecting to VGA Compatible System	1
Connecting to Two Computers(22" Model)	1
Installation of USB Function	3
4. OSD(On Screen Display) FUNCTIONS	
How to adjust the screen	1
Adjustment Items (22" Model)	2
Adjustment Items (19" Model)	5
Adjustment Items (17" Model)	8
5. TROUBLESHOOTING	
6. SPECIFICATIONS	
22" Model.....	1
19" Model.....	2
17" Model.....	3
7. APPENDIX	
Monitor Signal Input Connector (DB9-15P)	1
SC-B104 Signal Cable	1

WARNING!

This product is not designed for use in life support devices and Compaq Computer Corporation makes no representations to the contrary. Life support devices are those devices which are used to measure, diagnose, or evaluate the tissue, systems or functions of the human body; or other devices employed to support or sustain life or good health.

Trademark

©2000 Compaq Computer Corporation. COMPAQ and the Compaq logo are registered in the U.S. Patent and Trademark Office. Microsoft, Windows, and Windows NT are trademarks of Microsoft Corporation. All other product names mentioned herein may be trademarks of their respective companies. Compaq shall not be liable for technical or editorial errors or omissions contained herein. The information in this document is subject to change without notice. First Edition August 2000. ENERGY STAR is a U.S. registered mark.

1 INTRODUCTION

Congratulations on your purchase of the high resolution color monitor. We designed this monitor to provide you with years of reliable trouble-free operation.

This guide tells you how to connect, adjust and care for your monitor. This guide also provides technical specifications and instructions for troubleshooting any basic problems you may experience with your monitor.

Features

This monitor is an intelligent, microprocessor-based monitor compatible with most analog RGB (Red, Green, Blue) display standards available in the following sizes:

- 45 cm/17" (41cm/16" Diagonal Viewable Image)
- 50 cm/19" (46 cm/18" Diagonal Viewable Image)
- 55cm/22" (51cm/20" Diagonal Viewable Image)

It provides crisp text and vivid color graphics.

- The monitor's wide auto-scanning compatibility range makes it possible to upgrade video cards or software without purchasing a new monitor.
- Digitally controlled auto-scanning is done using an internal microprocessor. The microprocessor-based intelligence allows the monitor to operate in each frequency mode with the precision of a fixed frequency monitor. The monitor operates in the following frequencies:
 - 17" Monitor - horizontal scan frequencies between 30kHz and 96kHz, and vertical scan frequencies between 50Hz and 130Hz
 - 19" Monitor - horizontal scan frequencies between 30kHz and 108kHz, and vertical scan frequencies between 50Hz and 140Hz
 - 22" Monitor - horizontal scan frequencies between 30kHz and 121kHz, and vertical scan frequencies between 50Hz and 160Hz.
- The monitor contains resident memory for pre-programmed screen display standards and is also capable of storing additional user adjustment parameters.
- The monitor is capable of producing a non-interlaced maximum addressable resolution format of 1600 dots x 1200 lines (17" monitor), 1920 x 1440 lines (19" monitor) and 2048 dots x 1536 lines (22" monitor). This display is well suited for windowing environments.
- Because of the analog signal inputs, the monitor can display an unlimited palette of colors that can be manually adjusted to suit your specific needs.
- The monitor has a power management function accorded to VESA™-DPMS™-standard. To save energy, the monitor must be connected to a system compliant with the VESA™-DPMS™-standard. (Refer to your computer and/or video card instructions for proper operation.)
- To ensure ease of installation and ongoing use, the

monitor features On Screen Display (OSD) of all monitor set-up and adjustment functions.

- For use in a variety of applications, the monitor complies with UL 1950, CSA C22.2 No.950 and EN60950 for safety, FCC Class-B, VCCI Class-B and EN55022 Class-B for EMI, MPR-II, ISO 9241-3, ISO9241-7 and ISO9241-8 for ergonomics. The monitor also complies with TCO'99 guideline for environmental safe use.
- The world's standard DIAMONDTRON NF CRT upgraded with improved focus and convergence for super sharp and pure picture images.
- The monitor complies with Video Electronics Standards Association (VESA™) DDC™1/2B(EDID) specification. If your computer is Plug & Play compliant setup will be done automatically.
- The monitor provides:
 - fine 0.25mm aperture grille pitch/Maximum addressable resolution of 1600 x 1200 (17")
 - fine 0.24mm (for Northern hemisphere and 0.25/0.27mm for Southern hemisphere aperture grille pitch/Maximum addressable resolution of 1920 x 1440 (19")
 - fine 0.24mm aperture grille pitch/Maximum addressable resolution of 2048 x 1536 (22")
- The monitor has a contrast enhancement function (FPM: Fine Picture Mode) to accentuate pictures and graphical image.

Internal Preset Memory Capability

To minimize adjustment needs, the factory has preset popular display standards into the monitor, as shown in Table 1. If any of these display standards are detected by the microprocessor, the picture size and position are automatically adjusted. All of the factory presets may be overwritten by adjusting the user controls. This monitor is capable of automatically storing up to 15 additional display standards (22" model) or 16 additional display standards (17" and 19" models). The new display information must differ from any of the existing display standards by at least 1kHz for the horizontal scan frequency or 1Hz for the vertical scan frequency or the sync signal polarities must be different.

Table 1. Memory Buffer Factory Presets

22" Model

PRESET			Polarity			
TIMING			Fh(kHz)	Fv (Hz)	H	V
640	x	480 N.I.	31.5	60.0	-	-
640	x	480 N.I.	43.3	85.0	-	-
720	x	400 N.I.	31.5	70.1	-	+
800	x	600 N.I.	46.9	75.0	+	+
800	x	600 N.I.	53.7	85.1	+	+
1024	x	768 N.I.	75.0	75.1	+	+
1024	x	768 N.I.	68.7	85.0	+	+
1152	x	870 N.I.	68.7	75.1	-	-
1280	x	1024 N.I.	64.0	60.0	+	+
1280	x	1024 N.I.	80.0	75.0	+	+
1280	x	1024 N.I.	91.1	85.0	+	+
1600	x	1200 N.I.	93.8	75.0	+	+
1600	x	1200 N.I.	106.3	85.0	+	+
1792	x	1344 N.I.	83.6	60.0	-	+
1792	x	1344 N.I.	106.3	75.0	-	+
1800	x	1350 N.I.	120.4	85.0	-	-
1920	x	1440 N.I.	90.0	60.0	-	+
1920	x	1440 N.I.	112.5	75.0	-	+

19" Model

PRESET			Polarity			
TIMING			Fh(kHz)	Fv (Hz)	H	V
720	x	400 N.I.	31.5	70.0	-	+
640	x	480 N.I.	31.5	60.0	-	-
640	x	480 N.I.	43.3	85.0	-	-
800	x	600 N.I.	46.9	75.0	+	+
800	x	600 N.I.	53.7	85.1	+	+
1024	x	768 N.I.	60.0	75.0	+	+
1024	x	768 N.I.	68.7	85.0	+	+
1152	x	870 N.I.	68.7	75.1	-	-
1280	x	1024 N.I.	80.0	75.0	+	+
1280	x	1024 N.I.	91.1	85.0	+	+
1792	x	1344 N.I.	106.3	75.0	-	+
1920	x	1440 N.I.	90.0	60.0	-	+
1600	x	1200 N.I.	93.8	75.0	+	+
1600	x	1200 N.I.	106.3	85.0	+	+

17" Model

PRESET			Polarity			
TIMING			Fh(kHz)	Fv (Hz)	H	V
640	x	480 N.I.	31.5	60.0	-	-
640	x	480 N.I.	43.3	85.0	-	-
720	x	400 N.I.	31.5	70.1	-	+
800	x	600 N.I.	46.9	75.0	+	+
800	x	600 N.I.	53.7	85.1	+	+
1024	x	768 N.I.	60.0	75.0	+	+
1024	x	768 N.I.	68.7	85.0	+	+
1152	x	870 N.I.	68.7	75.1	-	-
1280	x	1024 N.I.	80.0	75.0	+	+
1280	x	1024 N.I.	91.1	85.0	+	+
1600	x	1200 N.I.	93.7	75.0	+	+

Power Management Function

The monitor has a power management function which reduces the power consumption of the monitor when not in use.

The power saving mode is invoked by a VESA DPMS-compliant computer. Check your computer's manual for setting this function.

22" Model

Mode	Power (with no USB operation)	Power-On Indicator
Normal	140 W	Green
Power Saving Mode	< or = 5 W	Amber

19" Model

Mode	Power	Power-On Indicator
Normal	120 W	Green
Power Saving Mode	< or = 5 W	Amber

17" Model

Mode	Power	Power-On Indicator
Normal	95 W	Green
Power Saving Mode	< or = 5 W	Amber

DDC

The monitor includes the VESA DDCTM1 and DDCTM2B feature. DDC (Display Data Channel) is a communication channel over which the monitor automatically informs the computer system about its capabilities (e.g. each supported resolution with its corresponding timing). DDC is routed through previously unused pins of the 15-pin VGA connector. The system will "Plug and Play" if both monitor and computer implement the DDC protocol.

Location Considerations

When setting up and using the monitor, keep the following in mind:

- For optimum viewing, avoid placing the monitor against a bright background or where sunlight or other light sources may reflect on the display area of the monitor. Place the monitor just below eye level.
- Place the monitor away from strong magnetic or electromagnetic fields, such as high capacity transformers, electric motors, large current power lines, steel pillars, etc.... Magnetism can cause distortion in the picture and/or color purity.
- Avoid covering the slots or openings of the monitor. Allow adequate ventilation around the monitor so the heat from the monitor can properly dissipate. Avoid putting the monitor into any enclosure that does not have adequate ventilation.
- Avoid exposing the monitor to rain, excessive moisture, or dust, as this can cause a fire or shock hazard.
- Avoid placing the monitor, or any other heavy object, on the power cord. Damage to the power cord can cause a fire or electrical shock.
- When transporting the monitor, handle it with care.

Cleaning Your Monitor

When cleaning the monitor, please follow these guidelines:

- Always unplug the monitor before cleaning.
- Wipe the screen and cabinet front and sides with a soft unspoil cloth to prevent causing imperfections.
- If the screen requires more than dusting, apply water or neutral detergent to a soft cloth to clean the monitor screen.

CAUTION

- *Do not use benzene, thinner or any volatile substances to clean the unit as the finish may be permanently marked.*
- *Never leave the monitor in contact with rubber or vinyl for an extended time period.*
- *Do not spray directly on the screen as cleaner may drip into the monitor and damage the circuitry.*
- *Never use an abrasive cleaner on the screen surface as this will damage the anti-reflection coating.*

Unpacking

After you unpack the box you should have all of the items indicated below. Save the box and packing materials in case you transport the monitor.

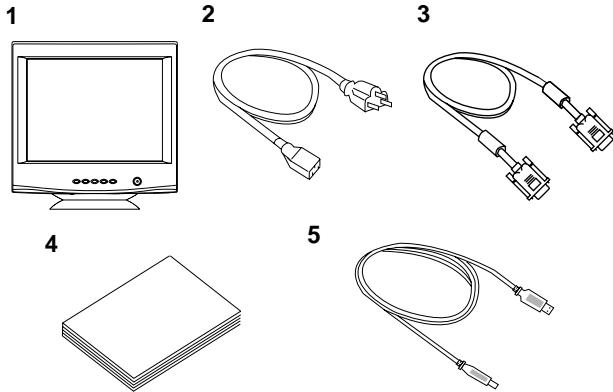

- | | |
|------------------|---|
| 1. Color Monitor | 4. User's Guide
(this document) |
| 2. AC Power Cord | 5. USB Upstream Cable
(22" model only) |
| 3. Signal Cable | |

Tilt/Swivel Base

The monitor comes with a tilt/swivel base. This enables you to position the monitor at the best angle and tilt for maximum viewing comfort.

Screen Position Adjustment

Adjust the tilt and rotation of the monitor by placing your hands at opposite sides of the case. You can adjust the monitor 90 degrees right or left, 10 degrees up or 5 degrees down (22" model), or 15 degrees up or 5 degrees down (17" and 19" models) as shown below.

22" Model

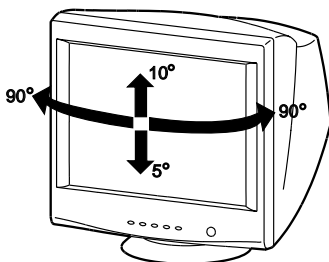

17" and 19" Models

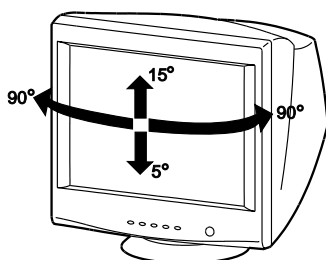

CAUTION

Keep your fingers away from the pivot area of the tilt/swivel base.

Quick Operation Chart

To summarize the steps in connecting your computer with the color monitor and setting the necessary controls and switches, refer to the chart below.

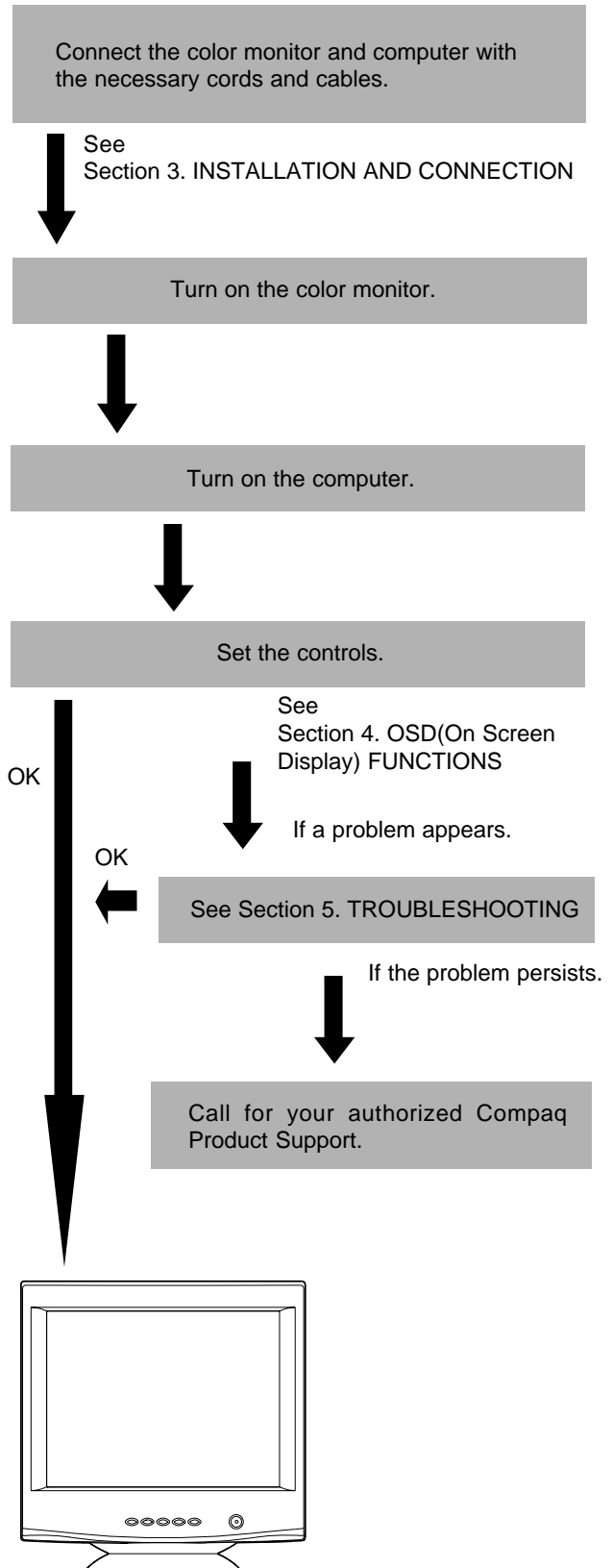

2 PART NAME

Control Names (17" & 19" Models)

See figures below for the location of the user controls, indicator and connectors. Each part is identified by number and is described individually.

FRONT

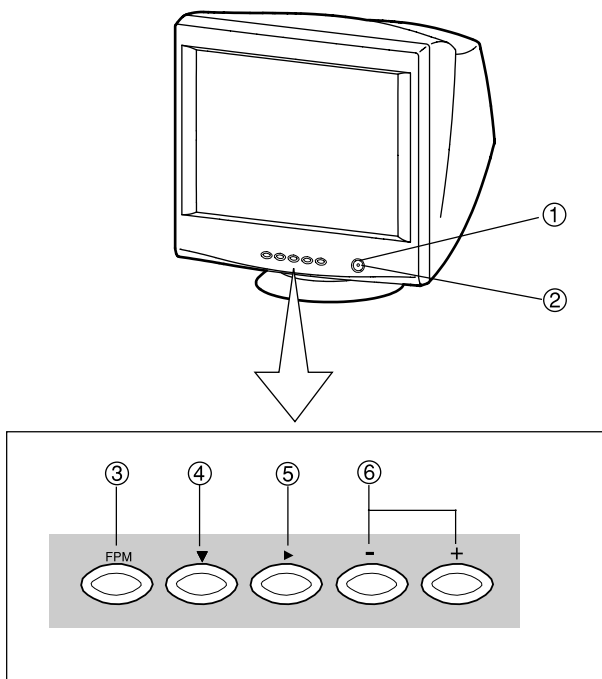

1. **POWER SWITCH:** A push-on / push-off switch for AC power.
2. **POWER-ON INDICATOR:** This indicator illuminates green when AC power is on, and illuminates amber when the monitor is in the power management modes.
3. **FPM (FINE PICTURE MODE):** Push to turn FPM on and off. The normal(default) status is "off", but turning this function "on" may improve camera type image renderings. Select the status which provides the most pleasing image.
Note that only standard color is selected when FPM is on.
4. **DOWN BUTTON:** Push to select group icon.
5. **ITEM SELECT BUTTON:** Push to select the item icon to be adjusted.
6. **FUNCTION ADJUST BUTTONS:** Push the adjust buttons to adjust the function that has been selected by the down button and item select button.

REAR

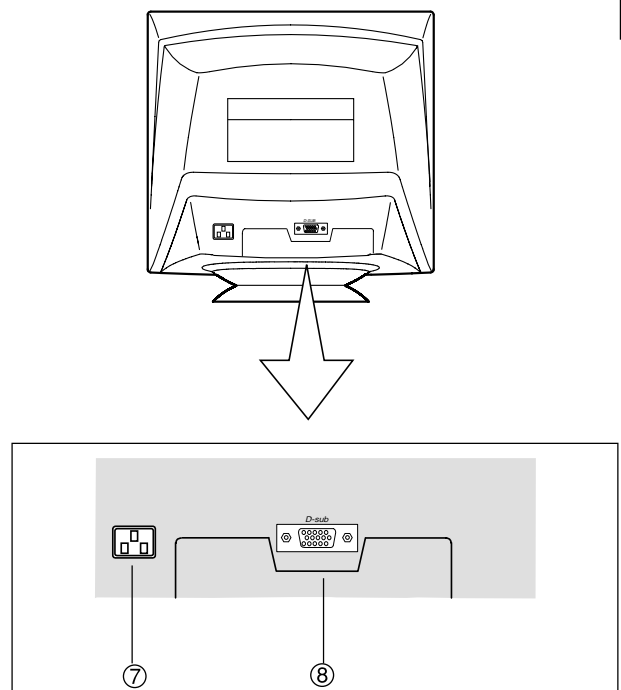

7. **AC POWER CONNECTOR**
8. **SIGNAL INPUT CONNECTOR (DB9-15P)**

Control Names (22" Model)

See figures below for the location of the user controls, indicator and connectors.

FRONT

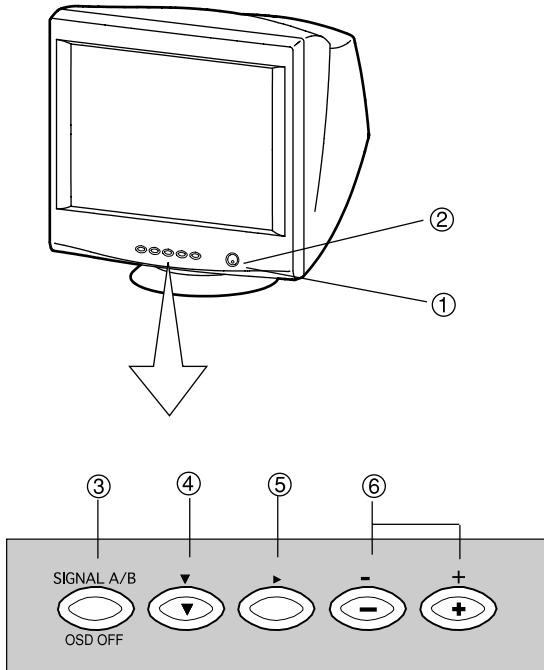

- 1. POWER SWITCH:** A push-on / push-off switch for AC power.
- 2. POWER-ON INDICATOR:** This indicator illuminates green when AC power is on, and illuminates amber when the monitor is in the power management modes.
- 3. INPUT CONNECTOR SELECT/OSD OFF BUTTON:**
 - Without OSD screen, push to select the signal input connector, SIGNAL A or B.
 - With OSD screen, push to turn the OSD screen off.

NOTE

If only one input is used, the monitor will select it automatically.

- 4. DOWN BUTTON:** Push to select group icon.
- 5. ITEM SELECT BUTTON:** Push to select the item icon.
- 6. FUNCTION ADJUST BUTTONS:** Push the adjust buttons to adjust the image on the screen.

REAR

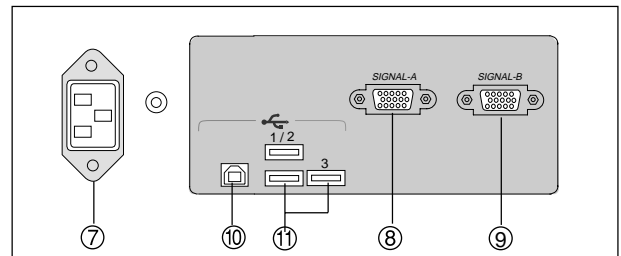
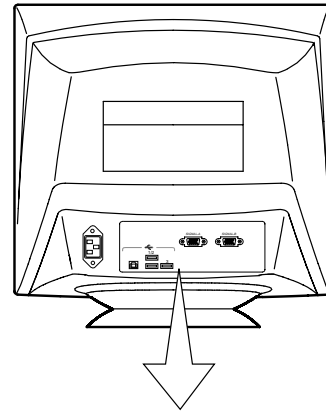

- 7. AC POWER CONNECTOR**
- 8. SIGNAL INPUT CONNECTOR (SIGNAL A): DB9-15P**
- 9. SIGNAL INPUT CONNECTOR (SIGNAL B): DB9-15P**
- 10. USB UPSTREAM PORT:** To connect to a USB equipped computer for Monitor Control Function.
- 11. USB DOWNSTREAM PORT:** To connect to USB equipped peripherals, e.g. USB camera, keyboard, printer, etc.

3 INSTALLATION AND CONNECTION

17" and 19" Models

On the back of the monitor two kinds of plug-in connections are provided: AC power connector for the AC input, DB9-15P connector for video signal input.

AC Power Connection

One end of the AC power cord is connected to the AC power connector on the back of the monitor. The other end is plugged into a properly grounded three-prong AC outlet. The monitor's auto-sensing power supply can automatically detect 100-120V AC or 220-240V AC and 50 or 60Hz.

Signal Cable Connection

The attached signal cable provides a DB9-15P connector for the VGA compatible analog RGB outputs on your computer. The figure below shows the included signal cable connection to the Video Graphics Array (VGA) port.

1. Power off, both the monitor and the computer.
2. Connect one end of the signal cable to the DB9-15P connector on the VGA controller card.
3. Connect the other end of the signal cable to the DB9-15P receptacle on the back of the monitor.
4. Power on the monitor, then the computer.
5. After using the system, power off the monitor, then the computer.

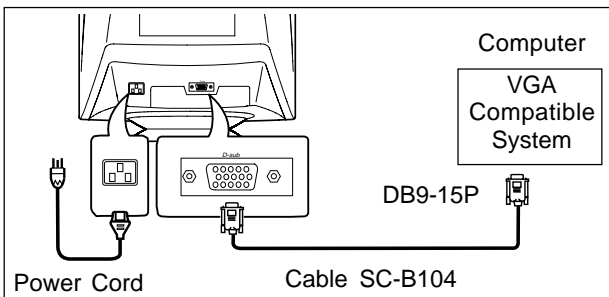

CAUTION

The socket-outlet shall be installed near the equipment and shall be easily accessible. During servicing, disconnect the plug from the socket-outlet.

22" Model

On the back of the monitor three kinds of plug-in connections are provided: AC power connector for the AC input, and two DB9-15P connectors for video signal input and USB ports for USB communication.

AC Power Connection

One end of the AC power cord is connected to the AC power connector on the back of the monitor. The other end is plugged into a properly grounded three-prong AC outlet. The monitor's auto-sensing power supply can automatically detect 100-120V AC or 220-240V AC and 50 or 60Hz.

Signal Cable Connection

The DB9-15P(VGA) connector is provided for compatible analog RGB outputs from your computer.

Connecting to VGA Compatible System

The figure below shows the SC-B104 cable connection to the Video Graphics Array (VGA) port in any VGA compatible system.

1. Power off, both the monitor and the computer.
2. Connect the one end of the SC-B104 cable to the DB9-15P connector on the VGA controller card.
3. Connect the other end of the SC-B104 cable to the DB9-15P receptacle on the back of the monitor.
4. Power on the monitor, then the computer.
5. After using the system, power off the monitor, then the computer.

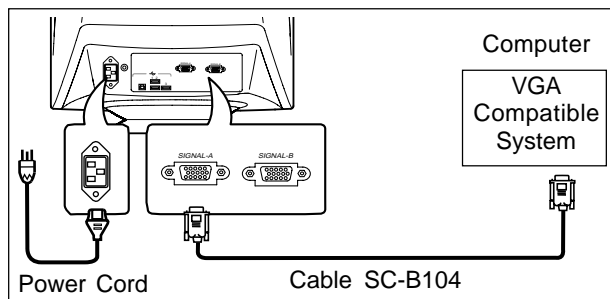

CAUTION

The socket-outlet shall be installed near the equipment and shall be easily accessible. During servicing, disconnect the plug from the socket-outlet.

Connecting to two computers (22" Model)

The figure below shows the connection to two computers.

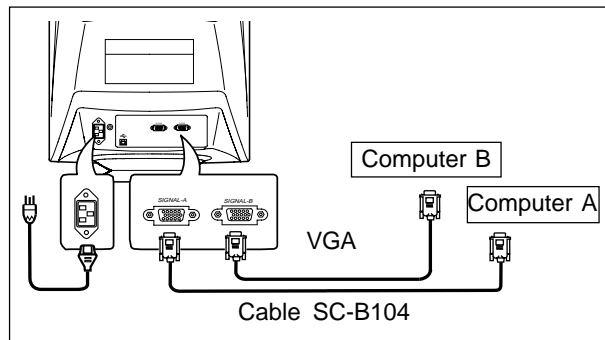

22" Model

USB System Basic Application

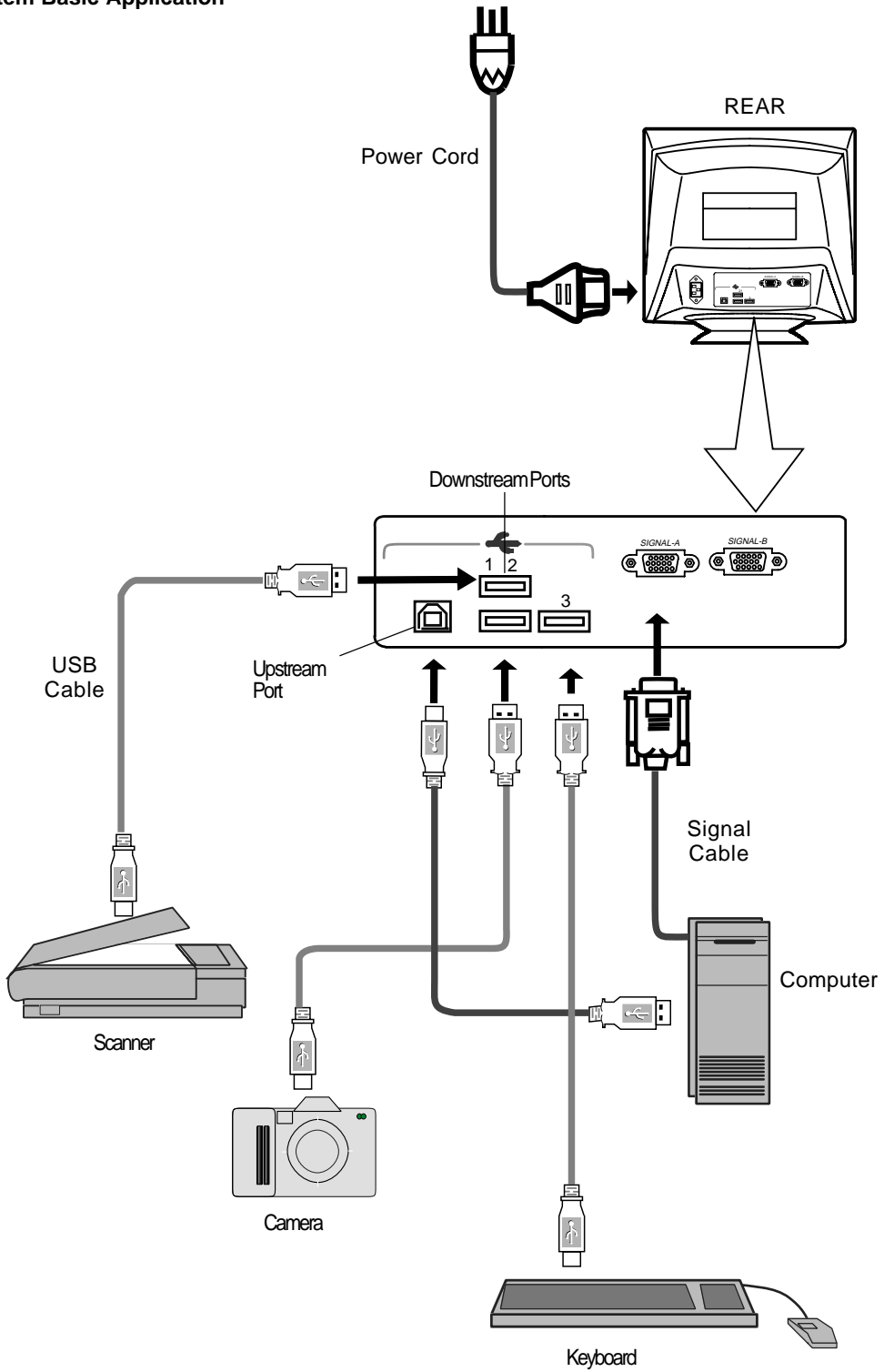

ENGLISH

NOTE

The computer is required to have Windows® 98 or later installed and USB functions.

Installation of USB Function

The following procedure permits your computer to recognize or "enumerate"(A USB term) the USB HUB.

1. Power on the display monitor and then the computer.
2. Start "Enumeration" from the Windows® Desktop.

NOTE

- During the enumeration of the USB Hub, connect the keyboard and mouse, to the computer and not to the downstream ports on the display monitor. After the enumeration, the keyboard and mouse can be used by connecting to the downstream ports, if they are USB-compliant.
- Do not unplug the USB cable during the enumerations.

- (1) Connect the computer and the display monitor with an USB cable. The screen below will appear.
- (2) Click "Next".
- (3) Click "Finish" on the second screen to complete the enumeration of the USB HUB.



You can confirm that the USB HUB is successfully enumerated with the following method.

- Open "Device Manager" tab in "System" property under "Control Panel". Confirm that "Generic USB HUB" is listed in "Universal Serial Bus Controller". If you can't confirm it, re-enumerate the USB HUB again by following (a) or (b).

- (a) Disconnect and connect the USB cable to the upstream port of the display monitor.
- (b) Cycle power of the display monitor off then on.

NOTE

If the mark ① appears with "Generic USB HUB", then enumeration was unsuccessful. Select "Generic USB HUB" marked with ① mark and click "Remove" and "Refresh". After that, the enumeration is automatically started.

NOTE

The enumeration of USB HUB may be necessary for each USB port on the computer.



4 OSD (On Screen Display) FUNCTIONS

How to adjust the screen

The monitor has an OSD(On Screen Display) function. The following procedure shows how to adjust the screen using the OSD function.

(1) Turn on the monitor.

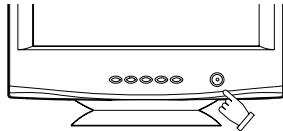

(2) Press button to display the OSD screen.

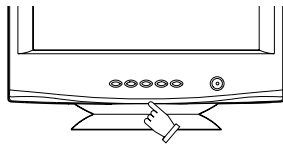

(3) Select the group icon on Main Menu by pressing .

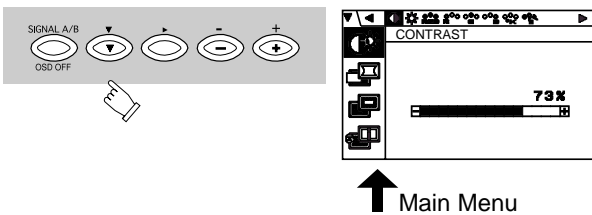

(4) Select the item icon on Sub Menu by pressing button.

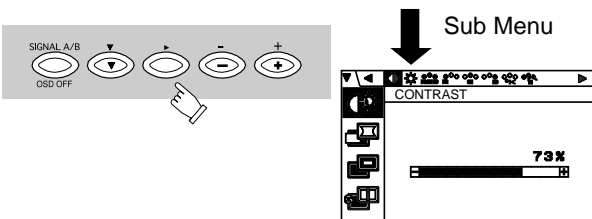

NOTE

When pressing both and buttons simultaneously, moving direction of item selection becomes reverse.

(5) Adjust by pressing or button.



(6) If you don't press any button for about 12 seconds, the OSD screen will disappear.

The 22" model OSD can be turned off quickly by pressing the OSD OFF button.

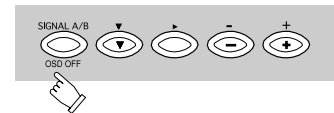
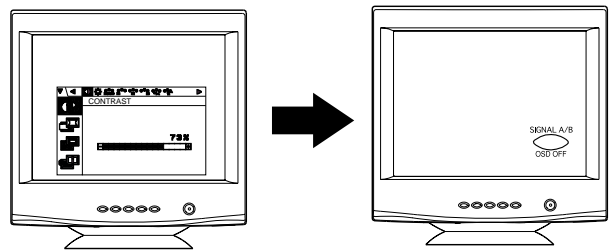



**Adjustment Items
22" Model**

X:Available





















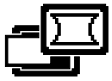





ENGLISH

Items	Function	A	B	C	D
CONTRAST	Adjusts the contrast level.		X	X	X
BRIGHT	Adjusts the black level of the screen		X	X	X
COLOR NO	Select the desired color from Color 1, Color 2, and Color 3 presets.			X	
R-GAIN	Adjusts the red-color balances for the selected color.		X	X	X
G-GAIN	Adjusts the green-color balances for the selected color.		X	X	X
B-GAIN	Adjusts the blue-color balances for the selected color.		X	X	X
COLOR TEMPERATURE	Adjusts the color temperature of the image on the screen.		X	X	X
COLOR RESET	Restores the each color gain and color temperature to the factory preset.	-	-	-	-
HORIZ-SIZE	Adjusts the horizontal size of the image on the screen.	X	X	X	
HORIZ-PHASE	Adjusts the horizontal position of the image on the screen.	X	X	X	
VERT-SIZE	Adjusts the vertical size of the image on the screen.	X	X	X	
VERT-POSITION	Adjusts the vertical position of the image on the screen.	X	X	X	
PINCUSHION	Straightens the left and right sides of the image on the screen.	X	X	X	
KEystone	Adjusts the parallelism of the left and right sides of the image on the screen.	X	X	X	
TOP-PIN	Adjusts the pincushioning at the top corners of the screen.	X	X	X	
BOTTOM-PIN	Adjusts the pincushioning at the bottom corners of the screen.	X	X	X	
PIN-BALANCE	Adjusts the curvature of the left and right sides of the image on the screen.	X	X	X	
KEY-BALANCE	Adjusts the vertical slant or tilt of the screen image.	X	X	X	
VERT-LIN-BALANCE	Centers the linearity of the vertical axis of the screen.	X	X	X	
VERT-LIN	Adjusts the linearity of the vertical axis of the screen.	X	X	X	
ROTATION	Adjusts the rotation of the image on the screen.		X	X	X
ZOOM	Zooms the screen to all sides.	X	X	X	
GEOMETRY RESET	Restores to the factory preset level.(See "NOTE" below.)	-	-	-	-
FINE PICTURE MODE	Selects the status which provides the most pleasing image.			X	
HORIZ-CONVERGENCE	Adjusts the horizontal alignment of the red, green and blue beams.		X	X	X
VERT-CONVERGENCE	Adjusts the vertical alignment of the red, green and blue beams.		X	X	X
CORNER PURITY (TL)	Adjusts the purity of the top-left corners of the screen.		X	X	X
CORNER PURITY (TR)	Adjusts the purity of the top-right corners of the screen.		X	X	X
CORNER PURITY (BL)	Adjusts the purity of the bottom-left corners of the screen.		X	X	X
CORNER PURITY (BR)	Adjusts the purity of the bottom-right corners of the screen.		X	X	X
MOIRE CANCEL	When setting to ON, the moire level on the screen can decreased by the MOIRE CANCEL LEVEL.			X	
MOIRE CANCEL LEVEL	Adjusts the moire level on the screen.		X	X	
CLAMP PULSE POSITION	Uses this function to eliminate excessive green or white background that may occur when both Sync-On-Green and external sync signals are applied to the monitor.			X	
VIDEO LEVEL	Selects video level 1.0V or 0.7V. (0.7V Standard)			X	
DEGAUSS	Eliminates possible color shading or impurity.	-	-	-	-
POWER SAVE	When setting to ON, the power consumption of the monitor will be reduced when not in use if your computer is set for power management.			X	X
CONTROL LOCK	Locks the OSD function except for "BRIGHT" and "CONTRAST".				X
OSD POSITION	Moves the OSD screen position.			X	X
ALL RESET	Restores all items to the factory preset level.(See "NOTE" below.)	-	-	-	-
GTF AUTO ADJUST	Adjusts the screen size and distortion automatically.	-	-	-	-
DIAGNOSIS	Indicates the current scanning frequency, factory or user preset timing number, and signal input connector.	-	-	-	-
LANGUAGE	Selects the language used on OSD screen.				X























- A. Press "GEOMETRY RESET" to restore to the factory preset level.
- B. Press  and  buttons together, to restore to the factory preset level.
- C. Press "ALL RESET" to restore to the factory preset level.
- D. Set data does not change by the change of the signal timing.

NOTE

If a non-Factory Preset timing is used, "GEOMETRY RESET" and "ALL RESET" do not work.

Group Icon	Item Icon	Item	Press the Minus Button 	Press the Plus Button 
		CONTRAST	To decrease the contrast.	To increase the contrast.
		BRIGHT	To decrease the brightness.	To increase the brightness.
		COLOR NO	To select color 1, color 2, color 3.	
		R-GAIN	To decrease red color level of the color mode selected by "COLOR NO".	To increase red color level of the color mode selected by "COLOR NO".
		G-GAIN	To decrease green color level of the color mode selected by "COLOR NO".	To increase green color level of the color mode selected by "COLOR NO".
		B-GAIN	To decrease blue color level of the color mode selected by "COLOR NO".	To increase blue color level of the color mode selected by "COLOR NO".
		COLOR TEMPERATURE	To decrease the color temperature of the color mode selected by "COLOR NO".	To increase the color temperature of the color mode selected by "COLOR NO".
		COLOR RESET	_____	To restore the color-gain and color temperature of the color mode selected by "COLOR NO" to the factory preset.
		HORIZ-SIZE	To narrow the width of the image on the screen.	To expand the width of the image on the screen.
		HORIZ-PHASE	To move the image on the screen to the left.	To move the image on the screen to the right.
		VERT-SIZE	To narrow the height of the image on the screen.	To expand the height of the image on the screen.
		VERT-POSITION	To move the image down.	To move the image up.
		PINCUSHION	To collapse the center of the image.	To expand the center of the image.
		KEystone	To decrease the width at the top of the screen image and to increase the width at the bottom.	To increase the width at the top of the screen image and to decrease the width at the bottom.
		TOP-PIN	To expand the width of the screen image near the corners of top.	To narrow the width of the screen image near the corners of top.
		BOTTOM-PIN	To expand the width of the screen image near the corners of bottom.	To narrow the width of the screen image near the corners of bottom.
		PIN-BALANCE	To move the top and bottom of the screen image to the right.	To move the top and bottom of the screen image to the left.
		KEY-BALANCE	To make the screen slant to the left.	To make the screen slant to the right.
		VERT-LIN-BALANCE	To vertically expand the bottom of the screen and compress the top.	To vertically compress the bottom of the screen and expand the top.
		VERT-LIN	To vertically compress the center of the screen and expand the top and bottom.	To vertically expand the center of the screen and compress the top and bottom.
		ROTATION	To rotate the image counterclockwise.	To rotate the image clockwise.
		ZOOM	To narrow the screen to all sides.	To expand the screen to all sides.
		GEOMETRY RESET	_____	To restore to factory preset level.

22" Model

Group Icon	Item Icon	Item	Press the Minus Button 	Press the Plus Button 	
		FINE PICTURE MODE	To select the status which provides the most pleasing image.		
		HORIZ-CONVERGENCE	To adjust the horizontal beam alignment on the full screen area.		
		VERT-CONVERGENCE	To adjust the vertical beam alignment on the full screen area.		
		CORNER PURITY(TL)	To adjust the purity condition on the top-left corner.		
		CORNER PURITY(TR)	To adjust the purity condition on the top-right corner.		
		CORNER PURITY(BL)	To adjust the purity condition on the bottom-left corner.		
		CORNER PURITY(BR)	To adjust the purity condition on the bottom-right corner.		
		MOIRE CANCEL	To select the Moire Cancel mode off.	To select the Moire Cancel mode on.	
		MOIRE CANCEL LEVEL	To decrease the level of the moire-clear wave.		
		CLAMP PULSE POSITION	To eliminate an excessive green or white-back ground that may occur when both Sync-On-Green and external sync signals are applied to the monitor.	To clamp the video signal at the front of the H-Sync pulse.	To clamp the video signal at the back of the H-Sync pulse.
		VIDEO LEVEL	To select 1.0V of video input.	To select 0.7V of video input.	
		DEGAUSS	To eliminate possible color shading or impurity due to magnetic effects.		
		POWER-SAVE	To select the constant power consumption mode.	To select the power-save mode. (Your computer must be set for power management.)	
		CONTROL LOCK	To unlock the OSD function.	To lock the OSD function except for "BRIGHT" and "CONTRAST".	
		OSD POSITION	To move the OSD screen position in a counter clockwise direction.	To move the OSD screen position in a clockwise direction.	
		ALL RESET	To restore all items to the factory preset.		
		GTF AUTO ADJUST	To adjust screen size, position and distortions automatically.		
		DIAGNOSIS	To show the current scanning frequency, Preset No., and signal input connection.		
		LANGUAGE	To choose the language used on OSD. ENG.....English, FRA.....French, ESP.....Spanish, ITA.....Italian, GER.....German, JPN.....Japanese		

NOTE

CONTROL LOCK: This is to lock the OSD function to keep the OSD screen image you set. Press plus button to lock the OSD function. You can adjust only "BRIGHT" and "CONTRAST" at the condition. Press minus button to unlock the locked condition.

GTF: This function is available when the computer has the GTF™ function according to the VESA®GTF™ standard.

Adjustment Items

19" Model

X = Available























Items	Function	X = Available		
		A	B	C
CONTRAST	Adjusts the contrast level.		X	X
BRIGHT	Adjusts the black level of the screen		X	X
COLOR TEMPERATURE	Adjusts the color temperature of the image on the screen.		X	X
HORIZ-SIZE	Adjusts the horizontal size of the image on the screen.	X		
HORIZ-PHASE	Adjusts the horizontal position of the image on the screen.	X		
VERT-SIZE	Adjusts the vertical size of the image on the screen.	X		
VERT-POSITION	Adjusts the vertical position of the image on the screen.	X		
PINCUSHION	Straightens the left and right sides of the image on the screen.	X		
KEYSTONE	Adjusts the parallelism of the left and right sides of the image on the screen.	X		
TOP-PIN	Adjusts the pincushioning at the top corners of the screen.	X		
BOTTOM-PIN	Adjusts the pincushioning at the bottom corners of the screen.	X		
PIN-BALANCE	Adjusts the curvature of the left and right sides of the image on the screen.	X		
KEY-BALANCE	Adjusts the vertical slant or tilt of the screen image.	X		
ROTATION	Adjusts the rotation of the image on the screen.			X
GEOMETRY RESET	Restores to the factory preset level.(See "NOTE" below.)	-	-	-
HORIZ-STATIC	Adjusts the horizontal alignment of the red, green and blue beams.		X	X
VERT-STATIC	Adjusts the vertical alignment of the red green and blue beams.		X	X
MOIRE CANCEL LEVEL	Adjusts the moire level on the screen.		X	
CORNER PURITY (TL)	Adjusts the purity of the top-left corners of the screen.		X	X
CORNER PURITY (TR)	Adjusts the purity of the top-right corners of the screen.		X	X
CORNER PURITY (BL)	Adjusts the purity of the bottom-left corners of the screen.		X	X
CORNER PURITY (BR)	Adjusts the purity of the bottom-right of the screen.		X	X
CLAMP PULSE POSITION	Uses this function to eliminate excessive green or white background that may occur when external sync signals are applied to the monitor.			
VIDEO LEVEL	Selects video level 1.0V or 0.7V. (0.7V Standard)			
DEGAUSS	Eliminates possible color shading or impurity.	-	-	-
POWER-SAVE	When setting to ON, the power consumption of the monitor will be reduced when not in use if your computer is set for power management.			X
CONTROL LOCK	Locks the OSD function except for "BRIGHT" and "CONTRAST".			X
OSD POSITION	Moves the OSD screen position.			X
DIAGNOSIS	Indicates the current scanning frequency, factory or user preset timing number, and signal input connector.	-	-	-
LANGUAGE	Selects the language used on OSD screen.			X

- A. Press "GEOMETRY RESET" to restore to the factory preset level.
- B. Press - and + buttons together, to restore to the factory preset level.
- C. Set data does not change by the change of the signal timing.

NOTE

If a non-Factory Preset timing is used, "GEOMETRY RESET" does not work.























19" Model

Group Icon	Item Icon	Item	Press the Minus Button   	Press the Plus Button   
 SCREEN		CONTRAST	To decrease the contrast.	To increase the contrast.
		BRIGHT	To decrease the brightness.	To increase the brightness.
		COLOR TEMPERATURE	To decrease the color temperature.	To increase the color temperature.
 GEOMETRY		HORIZ-SIZE	To narrow the width of the image on the screen.	To expand the width of the image on the screen.
		HORIZ-PHASE	To move the image on the screen to the left.	To move the image on the screen to the right.
		VERT-SIZE	To narrow the height of the image on the screen.	To expand the height of the image on the screen.
		VERT-POSITION	To move the image down.	To move the image up.
		PINCUSHION	To collapse the center of the image.	To expand the center of the image.
		KEYSTONE	To decrease the width at the top of the screen image and to increase the width at the bottom.	To increase the width at the top of the screen image and to decrease the width at the bottom.
		TOP-PIN	To expand the width of the screen image near the corners of top.	To narrow the width of the screen image near the corners of top.
		BOTTOM-PIN	To expand the width of the screen image near the corners of bottom.	To narrow the width of the screen image near the corners of bottom.
		PIN-BALANCE	To move the top and bottom of the screen image to the right.	To move the top and bottom of the screen image to the left.
		KEY-BALANCE	To make the screen slant to the left.	To make the screen slant to the right.
		ROTATION	To rotate the image counterclockwise.	To rotate the image clockwise.
		GEOMETRY RESET	_____	To restore to factory preset level.

ENGLISH

19" Model

ENGLISH

Group Icon	Item Icon	Item	Press the Minus Button   	Press the Plus Button   	
 VIDEO		HORIZ-STATIC	To adjust the horizontal beam alignment on the full screen area.		
		VERT-STATIC	To adjust the vertical beam alignment on the full screen area.		
		MOIRE CANCEL LEVEL	To decrease the level of the moire-clear wave.		
		CORNER PURITY(TL)	To adjust the purity condition on the top-left corner.		
		CORNER PURITY(TR)	To adjust the purity condition on the top-right corner.		
		CORNER PURITY(BL)	To adjust the purity condition on the bottom-left corner.		
		CORNER PURITY(BR)	To adjust the purity condition on the bottom-right corner.		
		CLAMP	CLAMPPULSEPOSITION	To eliminate an excessive green or white-back ground that may occur when external sync signals are applied to the monitor. To clamp the video signal at the front of the H-Sync pulse.	To clamp the video signal at the back of the H-Sync pulse.
		VIDEO LEVEL		To select 1.0V of video input.	To select 0.7V of video input.
 MISC.		DEGAUSS	To eliminate possible color shading or impurity due to magnetic effects.		
		POWER-SAVE	To select the constant power consumption mode.	To select the power-save mode. (Your computer must be set for power management.)	
		CONTROL LOCK	To permit all OSD adjustments.	To lock the OSD function except for "BRIGHT" and "CONTRAST".	
		OSD POSITION	To move the OSD screen position in a counter clockwise direction.	To move the OSD screen position in a clockwise direction.	
		DIAGNOSIS	Shows the current scanning frequency and Preset No..		
		LANGUAGE	To choose the language used on OSD. ENG.....English, FRA.....French, ESP.....Spanish, GER.....German, JPN.....Japanese		



Adjustment Items

17" Model





























X: Available

ENGLISH

Items	Function	A	B	C
CONTRAST	Adjusts the contrast level.		X	X
BRIGHT	Adjusts the black level of the screen.		X	X
COLOR TEMPERATURE	Adjusts the color temperature of the image on the screen.		X	X
HORIZ-SIZE	Adjusts the horizontal size of the image on the screen.	X		
HORIZ-PHASE	Adjusts the horizontal position of the image on the screen.	X		
VERT-SIZE	Adjusts the vertical size of the image on the screen.	X		
VERT-POSITION	Adjusts the vertical position of the image on the screen.	X		
PINCUSHION	Straightens the left and right sides of the image on the screen.	X		
KEYSTONE	Adjusts the parallelism of the left and right sides of the image on the screen.	X		
TOP-PIN	Adjusts the pincushioning at the top corners of the screen.	X		
BOTTOM-PIN	Adjusts the pincushioning at the bottom corners of the screen.	X		
PIN-BALANCE	Adjusts the curvature of the left and right sides of the screen image.	X		
KEY-BALANCE	Adjusts the vertical slant or tilt of the screen image.	X		
ROTATION	Adjusts the rotation of the image.			X
GEOMETRY RESET	Restore to the factory preset level. (Only function on factory preset timing)	-	-	-
*MOIRE CANCEL LEVEL	Adjusts the moire level on the screen.		X	
CLAMPULSEPOSITION	Use this function to eliminate excessive green or white background that may occur when external sync signals are applied to the monitor.			
VIDEO LEVEL	Selects video level 1.0V or 0.7V. (0.7V Standard)			
DEGAUSS	Eliminates possible color shading or impurity.	-	-	-
POWER-SAVE	When setting to ON, the power consumption of the monitor will be reduced when not in use.			X
CONTROL LOCK	Locks the OSD function to keep the screen you desired.			X
DIAGNOSIS	Indicates the current scanning frequency and factory or user preset timing number.			
LANGUAGE	Selects the language used on OSD screen.			X

- A. Press "GEOMETRY RESET" to restore to the factory preset level.
- B. Press  and  buttons together, to restore to the factory preset level.
- C. Set data does not change by the change of the signal timing.

*Moire is a series of wavy patterns caused by the interference between the aperture grille of the CRT and the raster generated by the video card. Adjust the level to the minimum value at which moire is no longer observed.

Group Icon	Item Icon	Item	Press the Minus Button 	Press the Plus Button 	
		CONTRAST	To decrease the contrast.	To increase the contrast.	
		BRIGHT	To decrease the brightness.	To increase the brightness.	
		COLORTEMPERATURE	To decrease the color temperature. NOTE When FPM is on, the color temperature is fixed to 9300K and it is not adjustable.	To increase the color temperature.	
		HORIZ-SIZE	To narrow the width of the image on the screen.	To expand the width of the image on the screen.	
		HORIZ-PHASE	To move the image to the left.	To move the image to the right.	
		VERT-SIZE	To narrow the height of the image on the screen.	To expand the height of the image on the screen.	
		VERT-POSITION	To move the image down.	To move the image up.	
		PINCUSHION	To collapse the center of the image.	To expand the center of the image.	
		KEYSTONE	To decrease the width at the top of the screen image and to increase the width at the bottom.	To increase the width at the top of the screen image and to decrease the width at the bottom.	
		TOP-PIN	To expand the width of the screen image near the corners of top.	To narrow the width of the screen image near the corners of top.	
		BOTTOM-PIN	To expand the width of the screen image near the corners of bottom.	To narrow the width of the screen image near the corners of bottom.	
		PIN-BALANCE	To move the top and bottom of the screen image to the right.	To move the top and bottom of the screen image to the left.	
		KEY-BALANCE	To make the screen slant to the left.	To make the screen slant to the right.	
		ROTATION	To rotate the image counterclockwise.	To rotate the image clockwise.	
		GEOMETRY RESET	_____	To restore to factory preset level.	
		MOIRE CANCEL LEVEL	To decrease the level of the moire-clear wave.		
		CLAMPPULSEPOSITION	To eliminate an excessive green or white-back ground that may occur when external sync signals are applied to the monitor. To clamp the video signal at the front of the H-Sync pulse.	To clamp the video signal at the back of the H-Sync pulse.	
		VIDEO LEVEL	To select 1.0V of video input.	To select 0.7V of video input.	
		DEGAUSS	_____	To eliminate possible color shading or impurity.	
		POWER-SAVE	To select the constant power consumption mode.	To select the power-save mode.	
		CONTROL LOCK	To permit all OSD adjustments.	To lock the OSD function except for "BRIGHT" and "CONTRAST".	
		DIAGNOSIS	It shows the current scanning frequency and Preset No. or user mode.		
		LANGUAGE	To choose the language used on OSD. ENG.....English, ESP.....Spanish, JPN.....Japanese, GER.....German, FRA.....French		

5 TROUBLESHOOTING

Before calling your 1-800-OK-COMPAQ for service, please check that the items below are properly connected or set. In case of using a non-standard signal, please check the pin assignments and the signal timing of your computer with the specification outlined in Section 6. SPECIFICATIONS and Section 7. APPENDIX.

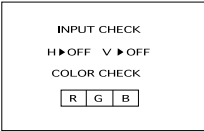
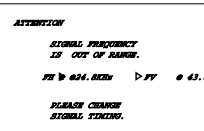
PROBLEM		ITEMS TO CHECK	LOCATION
No picture	LED On (Green)	<ul style="list-style-type: none"> Contrast and brightness controls. 	<ul style="list-style-type: none"> Front
	LED Off	<ul style="list-style-type: none"> Power switch. AC power cord disconnected. 	<ul style="list-style-type: none"> Front Rear
	LED On (Amber)	<ul style="list-style-type: none"> Signal cable disconnected. Computer power switch. Power management function is active. 	<ul style="list-style-type: none"> Rear Computer Press any key on the keyboard or move the mouse.
The following message appeared.		<ul style="list-style-type: none"> Signal cable disconnected. Computer power switch. Power management function is active. 	<ul style="list-style-type: none"> Rear Computer Press any key on the keyboard or move the mouse.
		<ul style="list-style-type: none"> Signal cable disconnected. Computer power switch. Power management function is active. 	<ul style="list-style-type: none"> Rear Computer Press any key on the keyboard or move the mouse.
The following message appeared.		<ul style="list-style-type: none"> Input signal frequency range is too high or too low for the monitor to synchronize with. 	<ul style="list-style-type: none"> Check the specification of graphics adapter
		<ul style="list-style-type: none"> Input signal frequency range is too high or too low for the monitor to synchronize with. 	<ul style="list-style-type: none"> Check the specification of graphics adapter
Abnormal picture	Display is missing, center shifts, or too small or too large of a display size	<ul style="list-style-type: none"> Do "GEOMETRY-RESET" or "ALL RESET" for a standard signal. Adjust HORIZ-SIZE, VERT-SIZE, HORIZ-PHASE, and VERT-POSITION with non-standard signals. Monitor may not be able to get full-screen image depend on signal. In this case, please select other resolution, or other vertical refresh timing. Make sure you wait a few seconds after adjusting the size of the image before changing or disconnecting the signal. 	<ul style="list-style-type: none"> Front (OSD) Front (OSD)
	Display is dark or too bright	<ul style="list-style-type: none"> "VIDEO LEVEL" is not at the appropriate position for your graphics adapter output. (0.7v or 1.0Vp-p). 	<ul style="list-style-type: none"> Front (OSD)

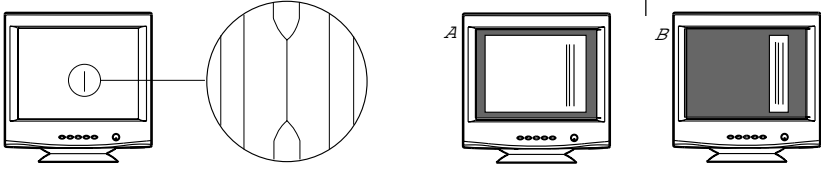
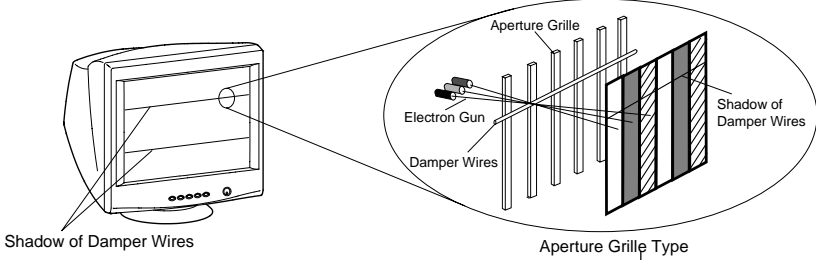
PROBLEM	ITEMS TO CHECK	LOCATION
<p>Abnormal Picture</p> <p>Black vertical lines are visible on the screen.</p>	<ul style="list-style-type: none"> Thin vertical black lines on one or both sides of the screen. This minor condition is caused by grille element overlap which can occur during shipping. <p>Position an open white window over the affected area of the screen and maximize the brightness and contrast controls. This will cause localized heating of the overlap which will clear in a few minutes. Be sure to readjust the brightness and contrast controls back to the normal viewing levels after this procedure.</p> 	<ul style="list-style-type: none"> —
<p>Two fine horizontal lines are visible on the screen.</p>	<ul style="list-style-type: none"> The 2 very faint thin lines across the screen are normal. They are caused by the aperture grille stabilization filaments (Damper Wires) which are required for all aperture grille CRTs'. 	<ul style="list-style-type: none"> —
<p>A buzzing sound when power on.</p>	<ul style="list-style-type: none"> A brief vibration or hum sound that is heard just after power up is normal. This is caused by the automatic degaussing function. This sound will be heard each time the monitor is powered up from a cold start and each time the manual degauss button is used. 	<ul style="list-style-type: none"> —

6 SPECIFICATIONS

22" Model

CRT	Size	55cm/22"(51cm/20" Diagonal Viewable Image)
	Mask type	Aperture grille
	Gun	In-line
	Deflection angle	90°
	Phosphors	Red, Green, Blue EBU (medium short persistence)
	Aperture grille pitch	0.24mm
	Phosphor pitch	0.25mm
	Face Plate	Anti-glare, Anti-reflection and Anti-static coating
	Focusing method	Dynamic Beam Forming (DBF)
INPUT SIGNAL	Video	0.7Vp-p analog RGB
	Sync	Separate H, V sync.
SIGNAL INTERFACE	Input Connectors	DB9-15P x 2
	Input Impedance	75 Ω (video), 2.2k Ω (sync.)
SCANNING FREQUENCY	Horizontal	30 - 121kHz
	Vertical	50 - 160Hz
RESOLUTION (HxV)	2048 dots x 1536 lines Non-Interlaced maximum addressable resolution format at 75Hz	
WARM-UP TIME	30 minutes to reach optimum performance level	
BRIGHTNESS	100cd/m ² , standard full white video signal at 9300K (+ 8MPCD)	
POWER SOURCE	AC100-120/220-240V±10% 50/60Hz 140W (typ.) < 155w (typ.) with USB operation>	
BLANKING TIME	Horizontal	≥ 2.3 μsec (typ.)
	Vertical	≥ 450 μsec (typ.)
DISPLAY SIZE	393mm x 295mm(typ.)	ratio 4:3
COLOR	5000K~9300K	
OPERATING ENVIRONMENT	Temperature	10- 35°C
	Humidity	20 - 80%RH (without condensation)
DIMENSIONS	(W)19.7inch x (H)19.7inch x (D)19.0inch / (W) 500mm x (H) 500mm x (D) 482mm	
WEIGHT	Approx. 30kg (66.14 lbs.)	
TILT/SWIVEL BASE	Tilt Angle	-5° - +10°
	Swivel Angle	±90°
REGULATIONS	Safety	UL1950 (UL), CSA C22.2 No.950 (C-UL) EN60950 (TÜV-GS), NEMKO, SEMKO, DEMKO, FIMKO
	EMC	FCC Class-B, DOC Class-B EN55022 Class-B, VCCI Class-B EN50082-1, EN61000-3-2, EN61000-3-3
	X-Ray	DHHS, HWC, Röv vom 8.1, 1987
	Other	CE-Marking, MPR-II/TCO'91 ISO9241-3, ISO9241-7, ISO9241-8 (TÜV-GS) TCO '99 International ENERGY STAR Program
USB	Functional	Self-powered HUB complying with Universal Serial Bus Specifications Rev 1.0
	Interface	1 Upstream port/12 Mbps 3 Downstream ports/12 Mbps, 1.5 Mbps (500mA max. per each downstream port)

19" Model

CRT	Size	50cm/19"(46cm/18" Diagonal Viewable Image)	
	Mask type	Aperture grille	
	Gun	In-line	
	Deflection angle	90°	
	Phosphors	Red, Green, Blue EBU (medium short persistence)	
	Aperture grille pitch	0.24mm	
	Face Plate	Anti-glare, Anti-reflection and Anti-static film	
	Focusing method	Dynamic Beam Forming (DBF)	
INPUT SIGNAL	Video	0.7 or 1.0Vp-p analog RGB	
	Sync	Separated H, V sync. or Composite sync	
SIGNAL INTERFACE	Input Connector	DB9 - 15P	
	Input Impedance	75 Ω (video), 2.2k Ω (sync.)	
SCANNING FREQUENCY	Horizontal	30 - 108kHz	
	Vertical	50 - 140Hz	
RESOLUTION (HxV)	1920dots x 1440lines Non-Interlaced maximum addressable resolution format at 60Hz Recommended Resolution: 1280 dots x 1024 lines at 85Hz		
WARM-UP TIME	30 minutes to reach optimum performance level		
BRIGHTNESS	110cd/m ² (typ.), standard full white video signal at 9300K (+ 27MPCD)		
BLANKING TIME	Horizontal	≥ 2.3 μsec (typ.)	
	Vertical	≥ 450 μsec (typ.)	
DISPLAY SIZE	350mm x 262mm(typ.)	ratio 4:3	
COLOR TEMPERATURE	5000K~9300K		
POWER SOURCE	AC100-120/220-240V±10% 50/60Hz 120W (typ.) (AC220-240V±10% 50/60Hz for Europe)		
OPERATING ENVIRONMENT	Temperature	10 - 35°C	
	Humidity	20 - 80%RH (without condensation)	
DIMENSIONS	(W)17.9inch x (H)18.2inch x (D)18.0inch / (W) 454mm x (H) 462mm x (D) 456mm		
WEIGHT	Approx. 23.0kg (50.7lbs.)		
TILT/SWIVEL BASE	Tilt Angle	-5° - +15°	
	Swivel Angle	±90°	
REGULATIONS	Safety	UL1950 (UL), CSA C22.2 No.950 (CSA) EN60950 (TÜV-GS), NEMKO, SEMKO, DEMKO, FIMKO	
	EMC	FCC Class-B, DOC Class-B, VCCI Class-B For only Europe: EN55022 Class-B, EN50082-1, EN61000-3-2, EN61000-3-3	
	X-Ray	DHHS, HWC, Röv vom 8.1, 1987	
	Other	CE-Marking, MPR-II/TCO'91 TCO '99, ISO9241-3,-7, and -8 (TÜV-GS) International ENERGY STAR Program	

17" Model

CRT	Size	45cm/17"(41cm/16" Diagonal Viewable Image)
	Mask type	Aperture grille
	Gun	In-line
	Deflection angle	90°
	Phosphors	Red, Green, Blue EBU (medium short persistence)
	Aperture grille pitch	0.25mm
	Face Plate	Anti-glare, Anti-reflection and Anti-static film
	Focusing method	Dynamic Beam Forming (DBF)
INPUT SIGNAL	Video	0.7Vp-p analog RGB
	Sync	Separated H, V sync. or Composite sync
SIGNAL INTERFACE	Input Connector	DB9 - 15P
	Input Impedance	75 Ω (video), 2.2k Ω (sync.)
SCANNING FREQUENCY	Horizontal	30 - 96kHz
	Vertical	50 - 130Hz
RESOLUTION (HxV)	1600dots x 1200lines Non-Interlaced maximum addressable resolution format at 75Hz Recommended Resolution: 1024 dots x 768 lines at 85Hz	
WARM-UP TIME	30 minutes to reach optimum performance level	
BRIGHTNESS	110cd/m ² , standard full white video signal at 9300K (+ 27MPCD)	
BLANKING TIME	Horizontal	> or = 2.7μsec (typ.)
	Vertical	> or = 500 μsec (typ.)
DISPLAY SIZE	312mm x 234mm(typ.)	ratio 4:3
COLORTemperature	5000K~9300K	
	AC100-120/220-240V±10% 50/60Hz 95W (typ.) (AC 220-240V + or - 10% 50 Hz for Europe)	
OPERATING ENVIRONMENT	Temperature	10 - 35°C
	Humidity	20 - 80%RH (without condensation)
DIMENSIONS	(W)16.1inch x (H)16.2inch x (D)17.1inch / (W) 410.2mm x (H) 412.6mm x (D) 435.3mm	
WEIGHT	Approx. 17.5 kg (38.6 lbs.)	
TILT/SWIVEL BASE	Tilt Angle	-5° - +15°
	Swivel Angle	±90°
REGULATIONS	Safety	UL1950 (UL), CSA C22.2 No.950 (C-UL) EN60950 (TÜV-GS), NEMKO, SEMKO, DEMKO, FIMKO
	EMC	FCC Class-B, DOC Class-B EN55022 Class-B EN50082-1, EN60555-2, EN61000-3-3
	X-Ray	DHHS, HWC, Röv vom 8.1, 1987
	Other	CE-Marking, MPR-II/TCO'91 TCO '99, ISO9241-3,-7, and -8 (TÜV-GS) International ENERGY STAR Program

7 APPENDIX

Monitor Signal Input Connector (DB9-15P)

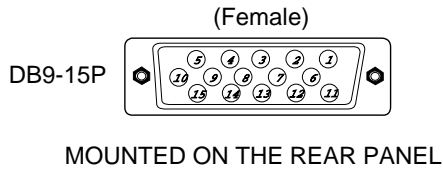

PIN ASSIGNMENTS

Pin No.	Signal
1	RED VIDEO
2	GREEN VIDEO or COMPOSITE SYNC with GREEN VIDEO
3	BLUE VIDEO
4	GROUND
5	DDC GROUND
6	RED GROUND
7	GREEN GROUND
8	BLUE GROUND
9	NC
10	SYNC GROUND
11	GROUND
12	SDA
13	HORIZONTAL SYNC or COMPOSITE SYNC
14	VERTICAL SYNC(VCLK)
15	SCL

DDC DISPLAY DATA CHANNEL
 SDA SERIAL DATA
 SCL SERIAL CLOCK
 NC NO-CONNECTION

SC-B104 Signal Cable

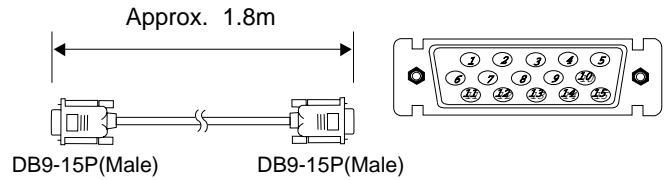

PIN ASSIGNMENTS

Pin No.	Signal
1	RED
2	GREEN
3	BLUE
4	GROUND
5	DDC GROUND
6	RED GROUND
7	GREEN GROUND
8	BLUE GROUND
9	NC
10	SYNC GROUND
11	GROUND
12	SDA
13	HORIZONTAL SYNC
14	VERTICAL SYNC(VCLK)
15	SCL

DDC DISPLAY DATA CHANNEL
 SDA SERIAL DATA
 SCL SERIAL CLOCK
 NC NO-CONNECTION

Regulatory Compliance Notices

Federal Communications Commission Notice

This equipment has been tested and found to comply with the limits for a Class B digital device, pursuant to Part 15 of the FCC Rules. These limits are designed to provide reasonable protection against harmful interference in a residential installation. This equipment generates, uses, and can radiate radio frequency energy and, if not installed and used in accordance with the instructions, may cause harmful interference to radio communications. However, there is no guarantee that interference will not occur in a particular installation. If this equipment does cause harmful interference to radio or television reception, which can be determined by turning the equipment off and on, the user is encouraged to try to correct the interference by one or more of the following measures:

- Reorient or relocate the receiving antenna.
- Increase the separation between the equipment and receiver.
- Connect the equipment into an outlet on a circuit different from that to which the receiver is connected.
- Consult the dealer or an experienced radio or television technician for help.

Modifications

The FCC requires the user to be notified that any changes or modifications made to this device that are not expressly approved by Compaq Computer Corporation may void the user's authority to operate the equipment.

Cables

Connections to this device must be made with shielded cables with metallic RFI/EMI connector hoods in order to maintain compliance with FCC Rules and Regulations.

Declaration of Conformity for products marked with the FCC logo - United States only

This device complies with Part 15 of the FCC Rules. Operation is subject to the following two conditions: (1) this device may not cause harmful interference, and (2) this device must accept any interference received, including interference that may cause undesired operation.

For questions regarding your product, contact:

Compaq Computer Corporation
P. O. Box 692000, Mail Stop 530113
Houston, Texas 77269-2000

Or, call

1-800- 652-6672 (1-800-OK COMPAQ)

For questions regarding this FCC declaration, contact:

Compaq Computer Corporation
P. O. Box 692000, Mail Stop 510101
Houston, Texas 77269-2000

Or, call

(281) 514-3333

Canadian Notice

This Class B digital apparatus meets all requirements of the Canadian Interference-Causing Equipment Regulations

Avis Canadien

Cet appareil numérique de la classe B respecte toutes les exigences du Règlement sur le matériel brouilleur du Canada.

European Union Notice

Products with the CE Marking comply with both the EMC Directive (89/336/EEC) and the Low Voltage Directive (73/23/EEC) issued by the Commission of the European Community.

Compliance with these directives implies conformity to the following European Norms (in brackets are the equivalent international standards):

- EN55022 (CISPR 22) - Electromagnetic Interference
- EN50082-1 (IEC801-2, IEC801-3, IEC801-4) - Electromagnetic Immunity
- EN60950 (IEC950) - Product Safety

Japanese Notice

この装置は、情報処理装置等電波障害自主規制協議会（VCCI）の基準に基づくクラスB情報技術装置です。この装置は、家庭環境で使用することを目的としていますが、この装置がラジオやテレビジョン受信機に近接して使用されると、受信障害を引き起こすことがあります。

取扱説明書に従って正しい取り扱いをして下さい。

Energy Star

Monitors that are marked with the Energy Star Logo meet the requirements of the EPA Energy Star program. As an Energy Star Partner, Compaq Computer Corporation has determined that this product meets the Energy Star guidelines for energy efficiency. Specific details on using the Energy Saving features can be found in the energy saver or power management section of the computer manual.



216028-001