



User Information Manual

701A
702A

SINGLE-PACKAGED ELECTRIC COOLING UNITS

Cancels: OM01-59

OM01-62
1-03

NOTE TO INSTALLER

This manual should be left with the equipment owner.

FOR YOUR SAFETY

Do not store or use gasoline or other flammable vapors and liquids in the vicinity of this or any other appliance.

 **WARNING:** Do not use this unit if any part has been under water. Immediately call a qualified service technician to inspect the unit and to replace any part of the control system which has been under water. Failure to follow this warning could result in electrical shock, fire, personal injury, or death.

 **WARNING:** Before performing recommended maintenance, be sure the main power switch to unit is turned off. Electric shock could cause personal injury or death.

TO START UNIT

- I. TURN ON THE ELECTRICAL POWER SUPPLY TO UNIT.
- II. SELECT TEMPERATURE AND SET SYSTEM SWITCH TO DESIRED MODE.

TO SHUT UNIT OFF

If unit is being shut down because of a malfunction, call your dealer as soon as possible.

- I. SET TEMPERATURE SWITCH TO OFF.
- II. TURN OFF THE ELECTRICAL POWER SUPPLY TO UNIT.

ROUTINE MAINTENANCE

All routine maintenance should be handled by skilled, experienced personnel. Your dealer can help you establish a standard procedure.

For your safety, keep the unit area clear and free of combustible materials, gasoline, and other flammable liquids and vapors.

To assure proper functioning of the unit, flow of condenser air must not be obstructed from reaching the unit. Clearance of at least 48 in. is required from top of unit and on sides except the power entry side (42 in. clearance) and the duct side (12 in. minimum clearance).

MAINTENANCE AND CARE FOR THE EQUIPMENT OWNER

Before proceeding with those things you might want to maintain yourself, please carefully consider the following:

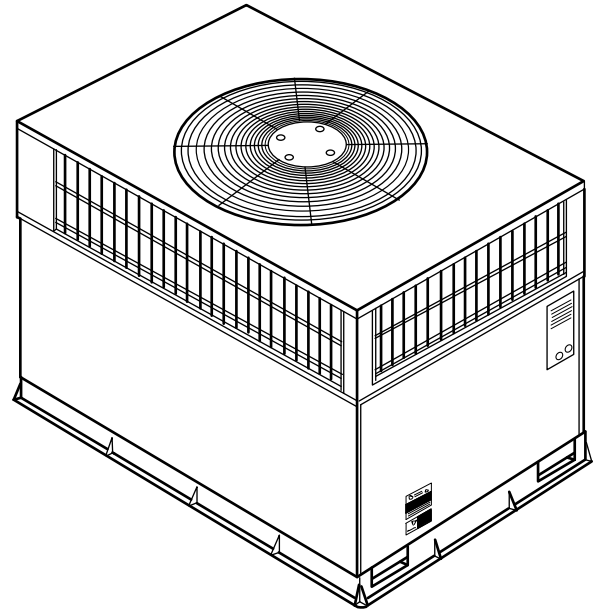



Fig. 1—Unit 701A and 702A

 **WARNING:**

1. TURN OFF ELECTRICAL POWER TO YOUR UNIT BEFORE SERVICING OR PERFORMING MAINTENANCE.
2. When removing access panels or performing maintenance functions inside your unit, be aware of sharp sheet metal parts and screws. Although special care is taken to reduce sharp edges to a minimum, be extremely careful when handling parts or reaching into the unit.

A. Air Filters

Air filter(s) should be checked at least every 3 or 4 weeks and changed or cleaned whenever it becomes dirty. Dirty filters produce excessive stress on the blower motor and can cause the motor to overheat and shut down. Table 1 indicates the correct filter size for your unit. Refer to Fig. 2 to access the filter(s).

To replace or inspect filter(s) (or accessory filter rack when supplied):

1. Remove the filter access panel using a 5/16-in. nut driver.
2. Remove the filter(s) by pulling the filter(s) out of the unit. If the filter(s) is dirty, clean or replace with new one.

When installing the new filter(s), note the direction of the airflow arrows on the filter frame.

If you have difficulty in locating your air filter(s), or if you have questions concerning proper filter maintenance, contact your dealer for instructions. When replacing filters, always use the same size and type of filter that was supplied originally by the installer.

TABLE 1 — INDOOR-AIR FILTER DATA

UNIT SIZE	FILTER SIZE
701A018-030	20x20
701A036-042	20x24
701A048-060	24x30
702A024-030	20x20
702A036	20x24
702A042-060	24x30

WARNING: Never operate your unit without filters in place. Failure to heed this warning may result in damage to the blower motor and/or compressor. An accumulation of dust and lint on internal parts of your unit can cause loss of efficiency and, in some cases, fire.

B. Fans and Fan Motor

Periodically check the condition of fan wheels and housings and fan-motor shaft bearings. No lubrication of condenser- or evaporator-fan bearings or motors is required or recommended.

C. Evaporator and Condenser Coils

Cleaning of the coils should only be done by qualified service personnel. Contact your dealer for the required annual maintenance.

D. Condensate Drain

The drain pan and condensate drain line should be checked and cleaned at the same time the cooling coils are checked by your dealer.

E. Compressor

All compressors are factory-shipped with a normal charge of the correct type refrigeration grade oil in them and should rarely require additional oil.

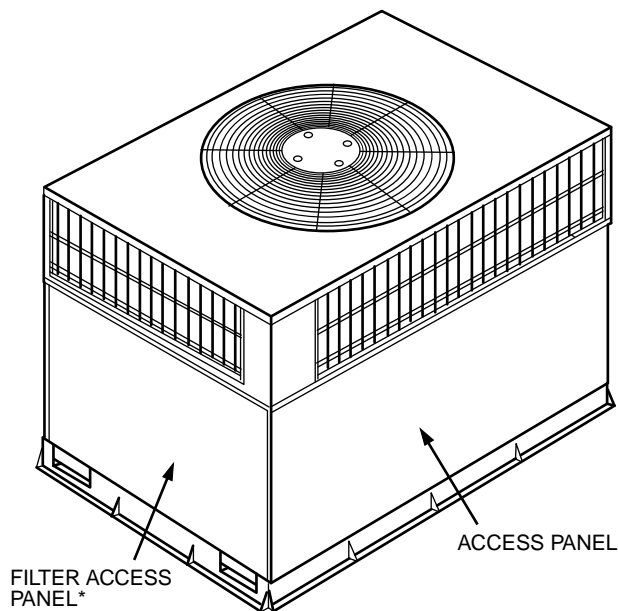

*For accessory filter rack.

Fig. 2—Filter Access Panel—Vertical Supply Shown

F. Condenser Fan

WARNING: Do not poke sticks, screwdrivers, or any other object into revolving fan blades. Severe bodily injury may result.

The fan must be kept free of all obstructions to ensure proper cooling. Contact your dealer for any required service.

G. Electrical Controls and Wiring

Electrical controls are difficult to check without proper instrumentations; therefore, if there are any discrepancies in the operating cycle, contact your dealer and request service.

H. Refrigerant Circuit

The refrigerant circuit is difficult to check for leaks without the proper equipment; therefore, if inadequate cooling is suspected, contact your local dealer for service.

WARNING: System under pressure. Relieve pressure and recover all refrigerant before system repair or final unit disposal to avoid personal injury or death. Use all service ports and open all flow-control devices, including solenoid valves.

I. Unit Panels

After performing any maintenance or service on the unit, be sure all panels are fastened securely in place to prevent rain from entering unit cabinet and to prevent disruption of the correct unit airflow pattern.

REGULAR DEALER MAINTENANCE

In addition to the type of routine maintenance you might be willing to perform, your unit should be inspected regularly by a properly trained service technician. An inspection (preferably each year, but at least every other year) should include the following:

1. Inspection and, if required, cleaning of the condenser and evaporator coils.
2. Inspection and, if required, cleaning of the evaporator drain pan.
3. Inspection and cleaning of blower wheel housing and motor.
4. Inspection of all supply-air and return-air ducts for leaks, obstructions, and insulation integrity. Any problems found should be resolved at this time.
5. Inspection of the unit base to ensure that no cracks, gaps, etc., exist which may cause a hazardous condition.
6. Inspection of the unit casing for signs of deterioration.
7. Inspection of all electrical wiring and components to assure proper connection.
8. Inspection for leaks in the refrigerant circuit. Pressure-check to determine appropriate refrigerant charge.
9. Inspection of compressor oil level by service person to ensure proper oil level is maintained in the compressor when it is installed and running.
10. Operational check of the unit to determine working conditions. Repair or adjustment should be made at this time.

Your servicing dealer may offer an economical service contract that covers seasonal inspections. Ask for further details.

Complete service instructions can be found in the unit Installation, Start-Up and Service Instructions.

WARRANTY CERTIFICATES

Unit 701A and 702A have limited warranties. Certificates are located at the back of this book. Be sure to read the warranty carefully to determine the coverage for your unit.

BEFORE YOU CALL FOR SERVICE, CHECK FOR SEVERAL EASILY-SOLVED PROBLEMS

If insufficient heating or cooling is suspected:

() Check for sufficient airflow. Check the air filter for dirt. Check for blocked return-air or supply-air grilles. Be sure they are open and unobstructed. If these checks do not reveal the cause, call your servicing dealer.

If your unit is not operating at all, check the following list for easy solutions:

() Check to be sure that your thermostat temperature selector is set below the indoor temperature during the cooling season. Be sure the system switch is in the COOL position and not in the OFF position.

() If your unit still fails to operate, call your servicing dealer for troubleshooting and repairs. Specify the model and serial numbers of your unit. (Record them in this manual in the space provided.) If the dealer knows exactly which unit you have, he may be able to offer suggestions over the phone, or save valuable time through knowledgeable preparation for the service call.

IN CASE OF TROUBLE

If after performing the above and unit performance is still unsatisfactory, shut off the unit and call your dealer.

Dealer's Name.....

Telephone

Unit Model

Unit Serial Number

