



installation and start-up instructions

11, 12, 13, 14 SEER
SPLIT-SYSTEM AIR CONDITIONERS
WITH PURON® REFRIGERANT

591B, 550A
552A, 556A

Cancels: II 550A-18-3

II 550A-18-4
11-03

NOTE: Read the entire instruction manual before starting the installation.

This symbol → indicates a change since the last issue.

SAFETY CONSIDERATIONS

Improper installation, adjustment, alteration, service, maintenance, or use can cause explosion, fire, electrical shock, or other conditions which may cause death, personal injury, or property damage. Consult a qualified installer, service agency, or your distributor or branch for information or assistance. The qualified installer or agency must use factory-authorized kits or accessories when modifying this product. Refer to the individual instructions packaged with the kits or accessories when installing.

Follow all safety codes. Wear safety glasses, protective clothing, and work gloves. Use quenching cloth for brazing operations. Have fire extinguisher available. Read these instructions thoroughly and follow all warnings or cautions included in literature and attached to the unit. Consult local building codes and National Electrical Code (NEC) for special requirements.

Recognize safety information. This is the safety-alert symbol . When you see this symbol on the unit and in instructions or manuals, be alert to the potential for personal injury.

Understand these signal words; DANGER, WARNING, and CAUTION. These words are used with the safety-alert symbol. **DANGER** identifies the most serious hazards which will result in severe personal injury or death. **WARNING** signifies hazards which could result in personal injury or death. **CAUTION** is used to identify unsafe practices which would result in minor personal injury or product and property damage. **NOTE** is used to highlight suggestions which **will** result in enhanced installation, reliability, or operation.



WARNING: Before installing, modifying, or servicing system, main electrical disconnect switch must be in the OFF position. There may be more than 1 disconnect switch. Lock out and tag switch with a suitable warning label. Electrical shock can cause personal injury or death.



CAUTION: Puron® systems operate at higher pressures than standard R-22 systems. To avoid damage to the unit or possible personal injury, do not use R-22 service equipment or components on Puron® equipment.

INSTALLATION RECOMMENDATIONS

NOTE: In some cases noise in the living area has been traced to gas pulsations from improper installation of equipment.

1. Locate unit away from windows, patios, decks, etc. where unit operation sound may disturb customer.
2. Ensure that vapor and liquid tube diameters are appropriate to capacity of unit.
3. Run refrigerant tubes as directly as possible by avoiding unnecessary turns and bends.

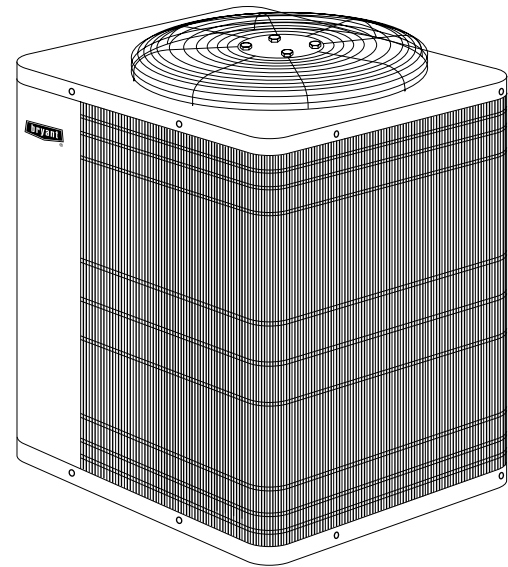

A98515

Fig. 1—Models 591B, 550A, 552A, and 556A

4. Leave some slack between structure and unit to absorb vibration.
5. When passing refrigerant tubes through the wall, seal opening with RTV or other pliable silicon-based caulk. (See Fig. 2.)
6. Avoid direct tubing contact with water pipes, duct work, floor joists, wall studs, floors, and walls.
7. Do not suspend refrigerant tubing from joists and studs with a rigid wire or strap which comes in direct contact with tubing. (See Fig. 2.)
8. Ensure that tubing insulation is pliable and completely surrounds vapor tube.
9. When necessary, use hanger straps which are 1 in. wide and conform to shape of tubing insulation. (See Fig. 2.)
10. Isolate hanger straps from insulation by using metal sleeves bent to conform to shape of insulation.

When outdoor unit is connected to factory-approved indoor unit, outdoor unit contains system refrigerant charge for operation with ARI rated indoor unit when connected by 15 ft of field-supplied or factory accessory tubing. For proper unit operation, check refrigerant charge using charging information located on control box cover and/or in the Check Charge section of this instruction.

IMPORTANT: Maximum liquid-line size is 3/8-in. O.D. for all residential applications including long line.

IMPORTANT: Always install the factory-supplied liquid-line filter drier. If replacing the filter drier, refer to Product Data Sheet for appropriate part number. Obtain replacement filter driers from your distributor or branch.

INSTALLATION

Specifications for this unit in residential new construction market require the outdoor unit, indoor unit, refrigerant tubing sets, metering device, and filter drier listed in presale literature. There

NOTE: Avoid contact between tubing and structure

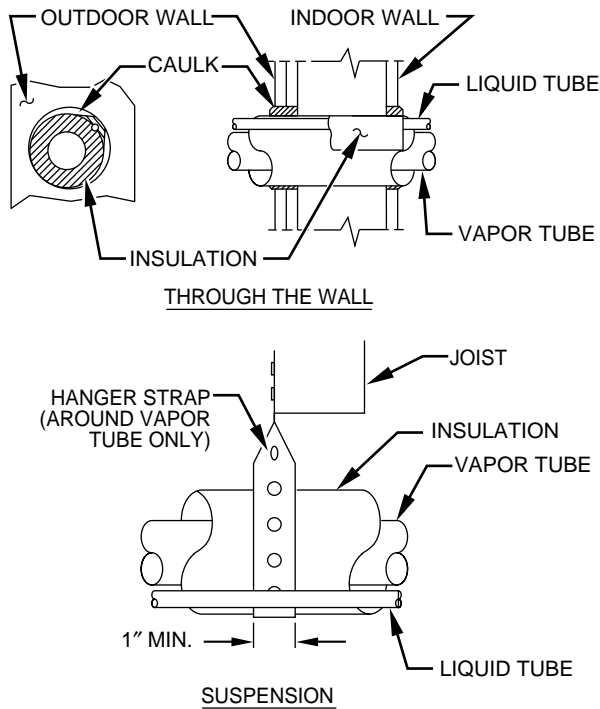

Fig. 2—Connecting Tubing Installation

can be no deviation. Consult the Application Guideline and Service Manual—Air Conditioners and Heat Pumps Using Puron® Refrigerant to obtain required unit changes for specific applications and for R-22 retrofit.

I. CHECK EQUIPMENT AND JOB SITE

A. UNPACK UNIT

Move to final location. Remove carton taking care not to damage unit.

B. INSPECT EQUIPMENT

File claim with shipping company prior to installation if shipment is damaged or incomplete. Locate unit rating plate on unit corner panel. It contains information needed to properly install unit. Check rating plate to be sure unit matches job specifications.

II. INSTALL ON A SOLID, LEVEL MOUNTING PAD

If conditions or local codes require the unit be attached to pad, tie down bolts should be used and fastened through knockouts provided in unit base pan. Refer to unit mounting pattern in Fig. 3 to determine base pan size and knockout hole location.

On rooftop applications, mount on level platform or frame. Place unit above a load-bearing wall and isolate unit and tubing set from structure. Arrange supporting members to adequately support unit and minimize transmission of vibration to building. Consult local codes governing rooftop applications.

Roof mounted units exposed to winds above 5 mph may require wind baffles. Consult the Application Guideline and Service Manual—Air Conditioner with Puron® Refrigerant for wind baffle construction.

NOTE: Unit must be level to within $\pm 2^\circ$ ($\pm 3/8$ in./ft) per compressor manufacturer specifications.

III. CLEARANCE REQUIREMENTS

When installing, allow sufficient space for airflow clearance, wiring, refrigerant piping, and service. Allow 30-in. clearance to service end of unit and 48 in. above unit. For proper airflow, a 6-in.

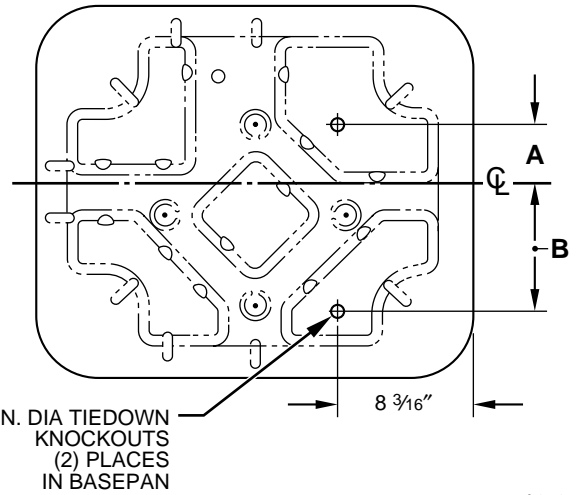

DIMENSIONS (IN.)

A97375

UNIT BASE PAN DIMENSIONS	TIEDOWN KNOCKOUT LOCATIONS	
	A	B
22-1/2 X 27-1/2	2-13/16	6-15/16
30 X 33	5-1/16	9-11/16

Fig. 3—Clearance Requirements

clearance on 1 side of unit and 12 in. on all remaining sides must be maintained. Maintain a distance of 24 in. between units. Position so water, snow, or ice from roof or eaves cannot fall directly on unit.

On rooftop applications, locate unit at least 6 in. above roof surface.

IV. OPERATING AMBIENT

The minimum outdoor operating ambient in cooling mode is 55°F, and the maximum outdoor operating ambient in cooling mode is 125°F.

→ V. CHECK INDOOR CHECK-FLO-RATER® PISTON AND INSTALL PISTON RING [STANDARD ON 591B, 550A (024-048 AND 060-G), AND 552A]

If unit is to be installed with a piston metering device, proceed as follows:

1. Check indoor coil piston to see if it matches the required piston shown on outdoor unit rating plate. If it does not match, replace indoor coil piston with piston shipped with outdoor unit. The piston shipped with outdoor unit is correct for any approved indoor coil combination.
2. After correct piston is installed, locate neoprene piston ring shipped in piston bag. Install piston ring behind metering piston as shown in Fig. 4. The piston ring ensures that piston stays seated during all operating conditions.

→ VI. INSTALL TXV

NOTE: ALL 556A and 550A060-H UNITS MUST BE INSTALLED WITH A HARD SHUT OFF PURON TXV.

The thermostatic expansion valve is specifically designed to operate with Puron®. **Do not use an R-22 TXV.** An existing R-22 TXV must be replaced with a factory-approved TXV specifically designed for Puron®.

NOTE: FK4 and FC4 fan coils are equipped with an R-22 TXV. If an FK4 or an FC4 fan coil is used with a Puron® air conditioner, the R-22 TXV must be replaced with a Puron® TXV or with the accessory piston body kit and piston shipped with outdoor unit.

IMPORTANT: The TXV should be mounted as close to the indoor coil as possible and in a vertical, upright position. Avoid mounting the inlet tube vertically down. Valve is more susceptible to malfunction due to debris if inlet tube is facing down. A factory-approved filter drier must be installed in the liquid line.

INSTALLING TXV IN PLACE OF PISTON

1. Pump system down to 2 psig and recover refrigerant.
2. Remove hex nut from piston body. Use backup wrench on fan coils.
3. Remove and discard factory-installed piston. Be sure teflon seal is in place.
4. Reinstall hex nut. Finger tighten nut plus 1/2 turn.

NOTE: If the piston is not removed from the body, TXV will not function properly.

⚠	CAUTION: To prevent damage to the unit, use a brazing shield and wrap TXV with wet cloth or use heat sink material.
---	--

5. Install TXV on indoor coil liquid line. Sweat swivel adapter to inlet of indoor coil and attach to TXV outlet. Use backup wrench to avoid damage to tubing or valve. Sweat inlet of TXV, marked "IN" to liquid line. Avoid excessive heat which could damage valve.
6. Install vapor elbow with equalizer adapter to suction tube of line set and suction connection to indoor coil. Adapter has a 1/4-in. male connector for attaching equalizer tube.
7. Connect equalizer tube of TXV to 1/4-in. equalizer fitting on vapor line adapter.
8. Attach TXV bulb to horizontal section of suction line using clamps provided. Insulate bulb with field-supplied insulation tape. See Fig. 5 for correct positioning of sensing bulb.
9. Proceed with remainder of unit installation.

REPLACING TXV ON R-22 INDOOR COIL

1. Pump system down to 2 psig and recover refrigerant.
2. Remove coil access panel and fitting panel from front of cabinet.

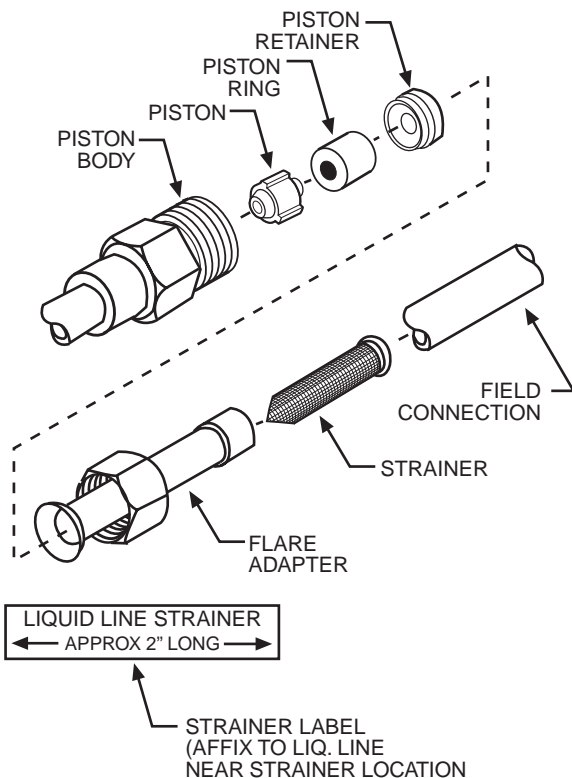
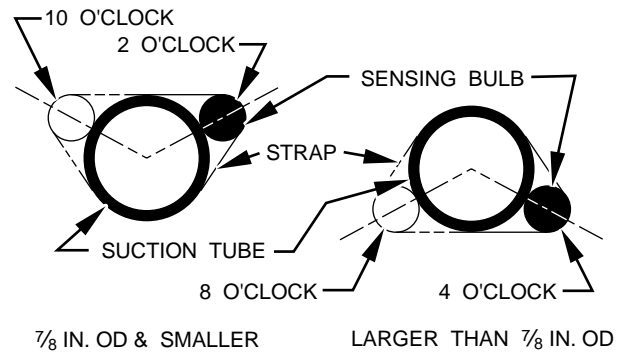

Fig. 4—Check-Flo-Rater® Components (550A, 552A, 591B Only)

A01019



A81032

Fig. 5—Position of Sensing Bulb

3. Remove TXV support clamp using a 5/16-in. nut driver. Save the clamp.
4. Remove R-22 TXV using a backup wrench on flare connections to prevent damage to tubing.
5. Using wire cutters, cut equalizer tube off flush with vapor tube inside cabinet.
6. Remove bulb from vapor tube inside cabinet.
7. Braze equalizer stub-tube closed. Use protective barrier as necessary to prevent damage to drain pan.

IMPORTANT: Route the equalizer tube of Puron® TXV through suction line connection opening in fitting panel prior to replacing fitting panel around tubing.

8. Install TXV with 3/8-in. copper tubing through small hole in service panel. Use wrench and backup wrench, to avoid damage to tubing or valve, to attach TXV to distributor.
9. Reinstall TXV support clamp (removed in item 3).
10. Attach TXV bulb to vapor tube inside cabinet, in same location as original was when removed, using supplied bulb clamps (nylon or copper). See Fig. 5 for correct positioning of sensing bulb.
11. Route equalizer tube through suction connection opening (large hole) in fitting panel and install fitting panel in place.
12. Sweat inlet of TXV, marked "IN" to liquid line. Avoid excessive heat which could damage valve.
13. Install vapor elbow with equalizer adapter to vapor line of line set and vapor connection to indoor coil. Adapter has a 1/4-in. male connector for attaching equalizer tube.
14. Connect equalizer tube of TXV to 1/4-in. equalizer fitting on vapor line adapter. Use backup wrench to prevent damage to equalizer fitting.
15. Proceed with remainder of unit installation.

⚠	CAUTION: To avoid improper performance and possible equipment failure, remove indoor coil piston if unit is to be installed on system with a TXV metering device.
---	--

VII. MAKE PIPING CONNECTIONS

⚠	WARNING: Relieve pressure and recover all refrigerant before system repair or final unit disposal to avoid personal injury or death. Use all service ports and open all flow-control devices, including solenoid valves.
---	---

TABLE 1—REFRIGERANT CONNECTIONS AND RECOMMENDED LIQUID AND VAPOR TUBE DIAMETERS (IN.)

UNIT SIZE	LIQUID		VAPOR		VAPOR (LONG LINE)	
	Connection Diameter	Tube Diameter	Connection Diameter	Tube Diameter	Connection Diameter	Tube Diameter
018, 024	3/8	3/8	5/8	5/8	5/8	3/4
030, 036	3/8	3/8	3/4	3/4	3/4	7/8
042, 048	3/8	3/8	7/8	7/8	7/8	1-1/8
060	3/8	3/8	7/8	1-1/8	7/8	1-1/8

NOTES:

1. Tube diameters are for lengths up to 50 ft. For tubing lengths greater than 50 ft, consult the Application Guideline and Service Manual—Air Conditioners and Heat Pumps Using Puron®.
2. Do not apply capillary tube indoor coils to these units.

TABLE 2—ACCESSORY USAGE

ACCESSORY	REQUIRED FOR LOW-AMBIENT APPLICATIONS (BELOW 55°F)	REQUIRED FOR LONG-LINE APPLICATIONS* (OVER 50 FT)	REQUIRED FOR SEA COAST APPLICATIONS (WITHIN 2 MILES)
Crankcase Heater	Yes	Yes	No
Evaporator Freeze Thermostat	Yes	No	No
Winter Start Control	Yes†	No	No
Accumulator	No	No	No
Compressor Start Assist Capacitor and Relay	Yes	Yes	No
MotorMaster® Control, or Low-Ambient Pressure Switch	Yes	No	No
Wind Baffle	See Low-Ambient Instructions	No	No
Coastal Filter	No	No	Yes
Support Feet	Recommended	No	Recommended
Liquid-Line Solenoid Valve or Hard Shutoff TXV	No	See Long-Line Application Guideline	No
Ball Bearing Fan Motor	Yes‡	No	No

* For Tubing Sets between 50 and 175 ft horizontal or 20 ft vertical differential, refer to the Application Guideline and Service Manual—Air Conditioners and Heat Pumps Using Puron®.

† Only when low-pressure switch is used.

‡ Required for low-ambient controller (full modulation feature) and MotorMaster® Control only.

CAUTION: To prevent improper performance and/or unit component failures, do not leave system open to atmosphere any longer than minimum required for installation. POE oil in compressor is extremely susceptible to moisture absorption. Always keep ends of tubing sealed during installation.

CAUTION: To prevent improper performance or equipment failure this caution must be followed. If ANY refrigerant tubing is buried, provide a 6 in. vertical rise at service valve. Refrigerant tubing lengths up to 36 in. may be buried without further special consideration. **Do not bury lines over 36 in. in length.**

CAUTION: To prevent damage to unit or service valves observe the following:

- Use a brazing shield.
- Wrap service valves with wet cloth or use a heat sink material.

Manual—Air Conditioners and Heat Pumps Using Puron® Refrigerant will reduce these losses. Refer to Table 1 for field tubing diameters. Refer to Table 2 for accessory requirements.

There are no buried-line applications greater than 36 in.

If refrigerant tubes or indoor coil are exposed to atmosphere, they must be evacuated to 500 microns to eliminate contamination and moisture in the system.

A. OUTDOOR UNIT CONNECTED TO FACTORY-APPROVED INDOOR UNIT

Factory refrigerant charge is for a 15 ft line set. Outdoor unit contains correct system refrigerant charge for operation with ARI rated indoor unit. Check refrigerant charge for maximum efficiency. The charge must be adjusted based on the actual line set length. Add *or subtract* 0.6 oz/ft for line sets longer *or shorter* than 15 ft.

B. INSTALL LIQUID-LINE FILTER DRIER

CAUTION: To avoid performance loss and compressor failure, installation of filter drier in liquid line is required.

Refer to Fig. 6 and install filter drier as follows:

1. Braze 5-in. connector tube to liquid service valve. Wrap filter drier with damp cloth.
2. Braze filter drier between connector tube and liquid tube to indoor coil. Flow arrow must point towards indoor coil.

Outdoor units may be connected to indoor section using accessory tubing package or field-supplied refrigerant grade tubing of correct size and condition. For tubing requirements beyond 50 ft, substantial capacity and performance losses can occur. Following the recommendations in the Application Guideline and Service

C. REFRIGERANT TUBING

Connect vapor tube to fitting on outdoor unit vapor service valves. Connect liquid tube to filter drier. (See Fig. 6 and Table 1.) Use refrigerant grade tubing.

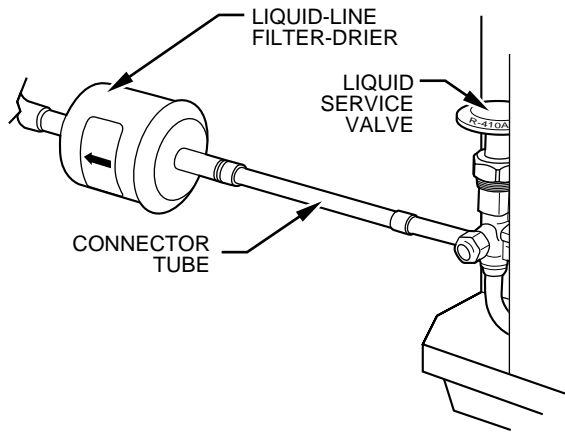

A95509

Fig. 6—Liquid-Line Filter Drier

D. SWEAT CONNECTION

CAUTION: To avoid valve damage while brazing, service valves must be wrapped in a heat-sinking material such as a wet cloth.

Use refrigerant grade tubing. Service valves are closed from factory and ready for brazing. After wrapping service valve with a wet cloth, braze sweat connections using industry accepted methods and materials. Consult local code requirements. Refrigerant tubing and indoor coil are now ready for leak testing. This check should include all field and factory joints.

E. EVACUATE REFRIGERANT TUBING AND INDOOR COIL

CAUTION: To avoid compressor damage, never use the system compressor as a vacuum pump.

Refrigerant tubes and indoor coil should be evacuated using the recommended deep vacuum method of 500 microns. The alternate triple evacuation method may be used if the procedure outlined below is followed. Always break a vacuum with dry nitrogen.

DEEP VACUUM METHOD

The deep vacuum method requires a vacuum pump capable of pulling a vacuum of 500 microns and a vacuum gage capable of accurately measuring this vacuum depth. The deep vacuum method is the most positive way of assuring a system is free of air and liquid water. (See Fig. 7.)

TRIPLE EVACUATION METHOD

The triple evacuation method should only be used when vacuum pump is only capable of pumping down to 28 in. of mercury vacuum and system does not contain any liquid water. Refer to Fig. 8 and proceed as follows:

1. Pump system down to 28 in. of mercury and allow pump to continue operating for an additional 15 minutes.
2. Close service valves and shut off vacuum pump.
3. Connect a dry nitrogen cylinder and regulator to system and open until system pressure is 2 psig.
4. Close service valve and allow system to stand for 1 hr. During this time, dry nitrogen will be able to diffuse throughout the system absorbing moisture.

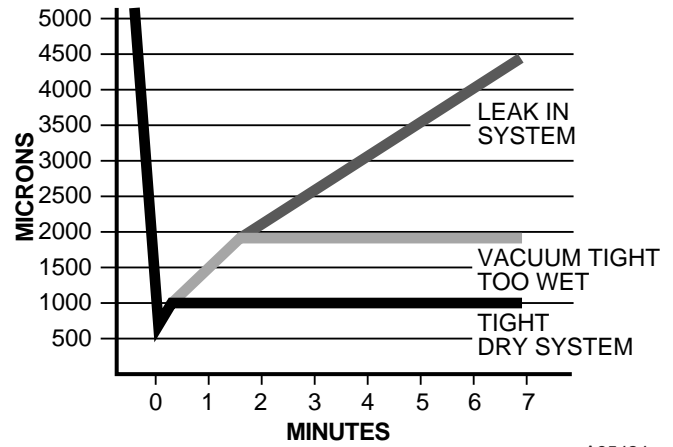

A95424

Fig. 7—Deep Vacuum Graph

5. Repeat this procedure as indicated in Fig. 8. System will then be free of any contaminants and water vapor.

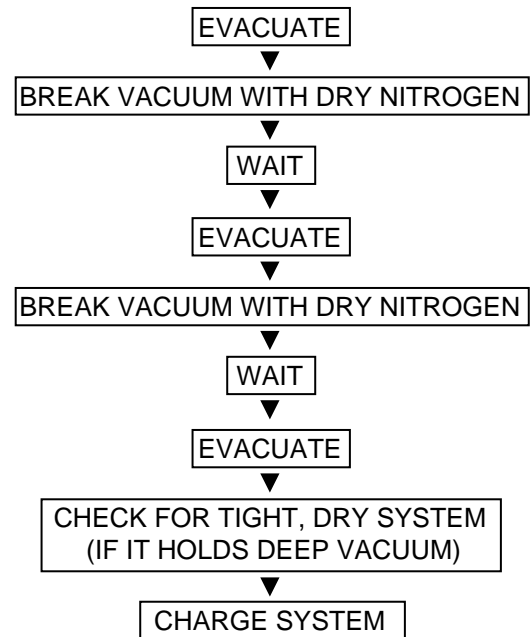

A95425

Fig. 8—Triple Evacuation Method

VIII. MAKE ELECTRICAL CONNECTIONS

WARNING: To avoid personal injury or death, do not supply power to unit with compressor terminal box cover removed.

Be sure field wiring complies with local and national fire, safety, and electrical codes, and voltage to system is within limits shown on unit rating plate. Contact local power company for correction of improper voltage. See unit rating plate for recommended circuit protection device.

NOTE: Operation of unit on improper line voltage constitutes abuse and could affect unit reliability. See unit rating plate. Do not install unit in system where voltage may fluctuate above or below permissible limits.

NOTE: Use copper wire only between disconnect switch and unit.

NOTE: Install branch circuit disconnect of adequate size per NEC to handle unit starting current. Locate disconnect within sight from and readily accessible from unit, per Section 440-14 of NEC.

A. ROUTE GROUND AND POWER WIRES

Remove access panel to gain access to unit wiring. Extend wires from disconnect through power wiring hole provided and into unit control box.

WARNING: The unit cabinet must have an uninterrupted or unbroken ground to minimize personal injury if an electrical fault should occur. The ground may consist of electrical wire or metal conduit when installed in accordance with existing electrical codes. Failure to follow this warning can result in an electric shock, fire, or death.

B. CONNECT GROUND AND POWER WIRES

Connect ground wire to ground connection in control box for safety. Connect power wiring to contactor as shown in Fig. 9.

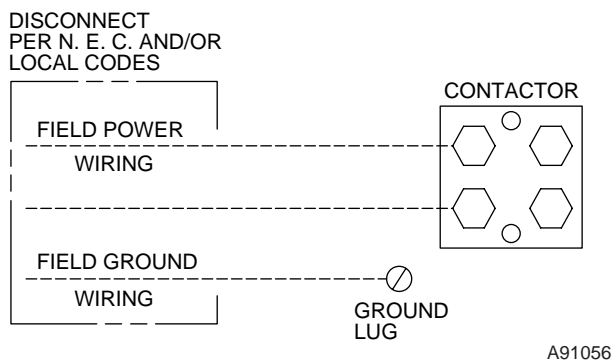

Fig. 9—Line Power Connections

C. CONNECT CONTROL WIRING

Route 24v control wires through control wiring grommet and connect leads to control wiring. (See Fig. 10.)

Use No. 18 AWG color-coded, insulated (35°C minimum) wire. If thermostat is located more than 100 ft from unit, as measured along the control voltage wires, use No. 16 AWG color-coded wire to avoid excessive voltage drop.

All wiring must be NEC Class 1 and must be separated from incoming power leads.

Use furnace transformer, fan coil transformer, or accessory transformer for control power, 24v/40va minimum.

NOTE: Use of available 24v accessories may exceed the minimum 40-va power requirement. Determine total transformer loading and increase the transformer capacity or split the load with an accessory transformer as required.

IX. COMPRESSOR CRANKCASE HEATER

When equipped with a crankcase heater, furnish power to heater a minimum of 24 hr before starting unit. To furnish power to heater only, set thermostat to OFF and close electrical disconnect to outdoor unit.

A crankcase heater is required if refrigerant tubing is longer than 50 ft. Refer to the Application Guideline and Service Manual—Air Conditioner and Heat Pump Using Puron® Refrigerant.

X. INSTALL ELECTRICAL ACCESSORIES

Refer to the individual instructions packaged with kits or accessories when installing.

XI. START-UP

CAUTION: To prevent compressor damage or personal injury, observe the following:

- Do not overcharge system with refrigerant.
- Do not operate unit in a vacuum or at negative pressure.
- Do not disable low-pressure switch.

In scroll compressor applications:

- Dome temperatures may be hot.

CAUTION: To prevent personal injury wear safety glasses, protective clothing, and gloves when handling refrigerant and observe the following:

- Back seating service valves are not equipped with Schrader valves. Fully back seat (counter clockwise) valve stem before removing gage port cap.
- Front seating service valves are equipped with Schrader valves.

CAUTION: Federal regulations require that you do not vent refrigerant to atmosphere. Recover during system repair or final unit disposal.

Follow these steps to properly start up the system:

1. After system is evacuated, fully back seat (open) liquid and vapor service valves.
2. Unit is shipped with valve stem(s) front seated (closed) and caps installed. Replace stem caps after system is opened to refrigerant flow (back seated). Replace caps finger-tight and tighten with wrench an additional 1/12 turn.
3. Close electrical disconnects to energize system.
4. Set room thermostat at desired temperature. Be sure set point is below indoor ambient temperature.
5. Set room thermostat to COOL and fan control to ON or AUTO mode, as desired. Operate unit for 15 minutes. Check system refrigerant charge.

A. SEQUENCE OF OPERATION

Turn on power to indoor and outdoor units. Transformer is energized.

On a call for cooling, thermostat makes circuits R-Y and R-G. Circuit R-Y energizes contactor, starting outdoor fan motor and compressor circuit. R-G energizes indoor unit blower relay, starting indoor blower motor on high speed.

When thermostat is satisfied, its contacts open, de-energizing contactor and blower relay. Compressor and motors stop.

If indoor unit is equipped with a time-delay relay circuit, the indoor blower will run an additional 90 sec to increase system efficiency.

XII. CHECK CHARGE

A. UNIT CHARGE

Factory charge and charging method are shown on unit information plate. **Puron® refrigerant cylinders contain a dip tube which allows liquid refrigerant to flow from cylinder in upright position.** Charge Puron® units with cylinder in upright position and a commercial-type metering device in manifold hose. Charge refrigerant into suction line.

NOTE: Charge must be adjusted in accordance with unit rating plate, ±0.6 oz/ft of 3/8-in. liquid line above or below 15 ft, respectively.

TABLE 3—REQUIRED LIQUID-LINE TEMPERATURE (°F)

LIQUID PRESSURE AT SERVICE VALVE (PSIG)	REQUIRED SUBCOOLING TEMPERATURE (°F)					
	8	10	12	14	16	18
189	58	56	54	52	50	48
195	60	58	56	54	52	50
202	62	60	58	56	54	52
208	64	62	60	58	56	54
215	66	64	62	60	58	56
222	68	66	64	62	60	58
229	70	68	66	64	62	60
236	72	70	68	66	64	62
243	74	72	70	68	66	64
251	76	74	72	70	68	66
259	78	76	74	72	70	68
266	80	78	76	74	72	70
274	82	80	78	76	74	72
283	84	82	80	78	76	74
291	86	84	82	80	78	76
299	88	86	84	82	80	78
308	90	88	86	84	82	80
317	92	90	88	86	84	82
326	94	92	90	88	86	84
335	96	94	92	90	88	86
345	98	96	94	92	90	88
354	100	98	96	94	92	90
364	102	100	98	96	94	92
374	104	102	100	98	96	94
384	106	104	102	100	98	96
395	108	106	104	102	100	98
406	110	108	106	104	102	100
416	112	110	108	106	104	102
427	114	112	110	108	106	104
439	116	114	112	110	108	106
450	118	116	114	112	110	108
462	120	118	116	114	112	110
474	122	120	118	116	114	112
486	124	122	120	118	116	114
499	126	124	122	120	118	116
511	128	126	124	122	120	118

EXAMPLE:

To calculate additional charge required for a 25-ft line set:
 25 ft - 15 ft = 10 ft X 0.6 oz/ft = 6 oz of additional charge.

B. COOLING ONLY PROCEDURE

UNITS WITH COOLING MODE PURON® TXV

Units installed with cooling mode TXV require charging by the subcooling method.

1. Operate unit a minimum of 10 minutes before checking charge.
2. Measure liquid service valve pressure by attaching an accurate gage to service port.
3. Measure liquid line temperature by attaching an accurate thermistor type or electronic thermometer to liquid line near outdoor coil.
4. Refer to unit rating plate for required subcooling temperature.
5. Refer to Table 3. Find the point where required subcooling temperature intersects measured liquid service valve pressure.

6. To obtain required subcooling temperature at a specific liquid line pressure, add refrigerant if liquid line temperature is higher than indicated or reclaim refrigerant if temperature is lower. Allow a tolerance of ± 3°F.

UNITS WITH INDOOR PISTONS

Units installed with indoor pistons require charging by the superheat method.

The following procedure is valid when indoor airflow is within ± 21 percent of its rated CFM.

1. Operate unit a minimum of 10 minutes before checking charge.
2. Measure suction pressure by attaching an accurate gage to suction valve service port.
3. Measure suction temperature by attaching an accurate thermistor type or electronic thermometer to suction line at service valve.
4. Measure outdoor air dry-bulb temperature with thermometer.
5. Measure indoor air (entering indoor coil) wet-bulb temperature with a sling psychrometer.

TABLE 4—SUPERHEAT CHARGING

OUTDOOR TEMP (°F)	EVAPORATOR ENTERING AIR TEMPERATURE (°F WB)													
	50	52	54	56	58	60	62	64	66	68	70	72	74	76
55	9	12	14	17	20	23	26	29	32	35	37	40	42	45
60	7	10	12	15	18	21	24	27	30	33	35	38	40	43
65	—	6	10	13	16	19	21	24	27	30	33	36	38	41
70	—	—	7	10	13	16	19	21	24	27	30	33	36	39
75	—	—	—	6	9	12	15	18	21	24	28	31	34	37
80	—	—	—	—	5	8	12	15	18	21	25	28	31	35
85	—	—	—	—	—	—	8	11	15	19	22	26	30	33
90	—	—	—	—	—	—	5	9	13	16	20	24	27	31
95	—	—	—	—	—	—	—	6	10	14	18	22	25	29
100	—	—	—	—	—	—	—	—	8	12	15	20	23	27
105	—	—	—	—	—	—	—	—	5	9	13	17	22	26
110	—	—	—	—	—	—	—	—	—	6	11	15	20	25
115	—	—	—	—	—	—	—	—	—	—	8	14	18	23

Where a dash (—) appears, do not attempt to charge system under these conditions or refrigerant slugging may occur. Charge must be weighed in.
NOTE: Superheat °F is at low-side service port.

- Refer to Table 4. Find outdoor temperature and evaporator entering air wet-bulb temperature. At this intersection, note superheat.
- Refer to Table 5. Find superheat temperature located in item 6 and suction pressure. At this intersection, note suction line temperature.
- If unit has a higher suction line temperature than charted temperature, add refrigerant until charted temperature is reached.
- If unit has a lower suction line temperature than charted temperature, reclaim refrigerant until charted temperature is reached.
- When adding refrigerant, charge in liquid form into suction service port using a flow-restricting device.
- If outdoor air temperature or pressure at suction valve changes, charge to new suction line temperature indicated on chart.
- Ensure that all wiring and tubing is secure in unit before adding panels and covers. Securely fasten all panels and covers.
- Tighten service valve stem caps to 1/12-turn past finger tight.
- Leave User’s Manual with owner. Explain system operation and periodic maintenance requirements outlined in manual.
- Fill out Dealer Installation Checklist and place in customer file.

CARE AND MAINTENANCE

For continuing high performance and to minimize possible equipment failure, periodic maintenance must be performed on this equipment.

Frequency of maintenance may vary depending upon geographic areas, such as coastal applications. See Users Manual for information.

XIII. FINAL CHECKS

IMPORTANT: Before leaving job, be sure to do the following:

- Ensure that all wiring is routed away from tubing and sheet metal edges to prevent rub-through or wire pinching.

TABLE 5—REQUIRED SUCTION-LINE TEMPERATURE

SUPERHEAT TEMP (°F)	SUCTION PRESSURE AT SERVICE PORT (PSIG)								
	107.8	112.2	116.8	121.2	126.0	130.8	138.8	140.8	145.8
0	35	37	39	41	43	45	47	49	51
2	37	39	41	43	45	47	49	51	53
4	39	41	43	45	47	49	51	53	55
6	41	43	45	47	49	51	53	55	57
8	43	45	47	49	51	53	55	57	59
10	45	47	49	51	53	55	57	59	61
12	47	49	51	53	55	57	59	61	63
14	49	51	53	55	57	59	61	63	65
16	51	53	55	57	59	61	63	65	67
18	53	55	57	59	61	63	65	67	69
20	55	57	59	61	63	65	67	69	71
22	57	59	61	63	65	67	69	71	73
24	59	61	63	65	67	69	71	73	75
26	61	63	65	67	69	71	73	75	77
28	63	65	67	69	71	73	75	77	79
30	65	67	69	71	73	75	77	79	81
32	67	69	71	73	75	77	79	81	83
34	69	71	73	75	77	79	81	83	85
36	71	73	75	77	79	81	83	85	87
38	73	75	77	79	81	83	85	87	89
40	75	77	79	81	83	85	87	89	91

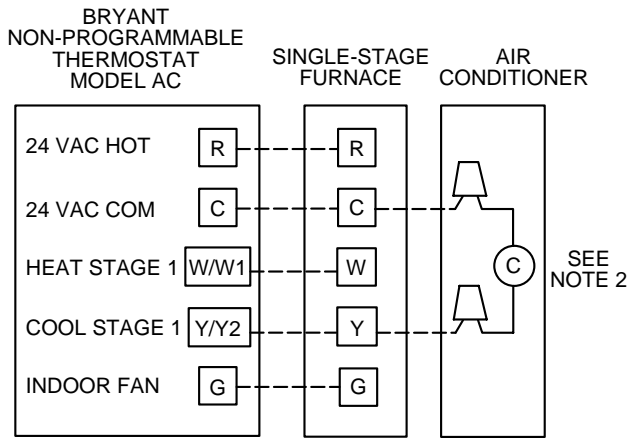

A97359

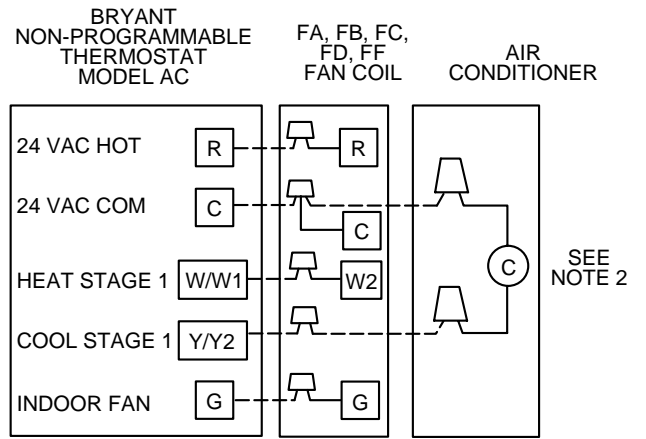

A97360

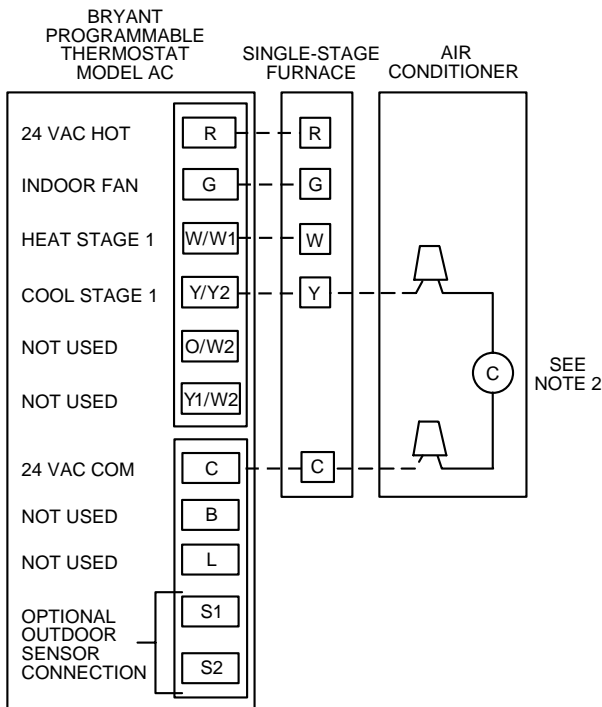

A97361

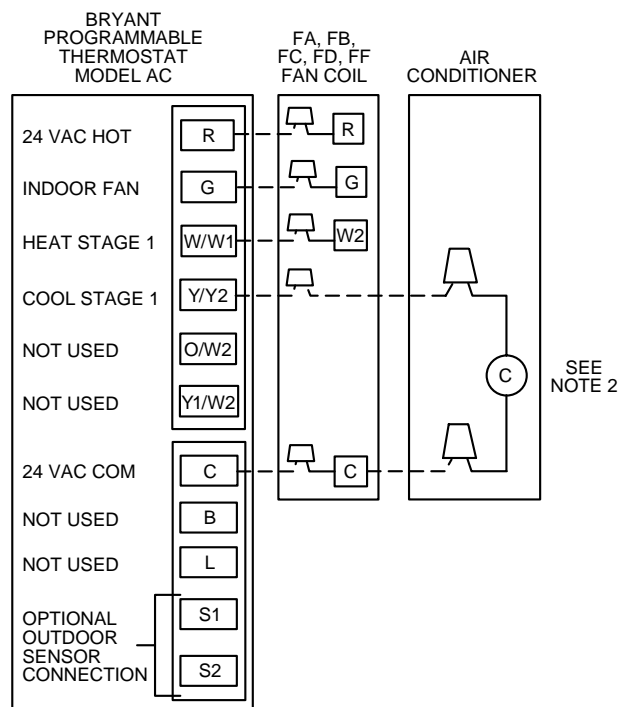

A97362

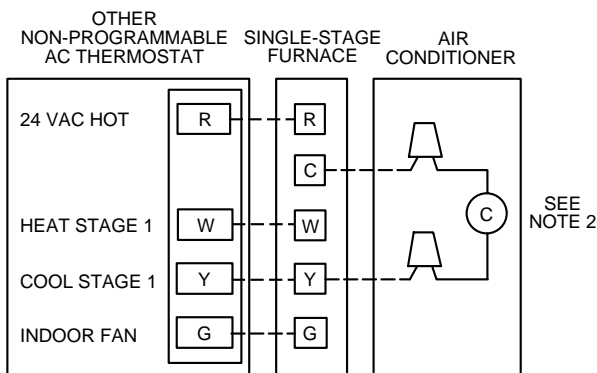

A97367

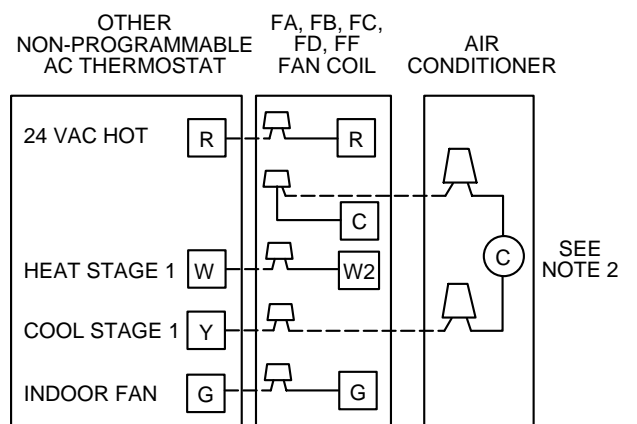

A97366

Fig. 10—Typical 24v Circuit Connections

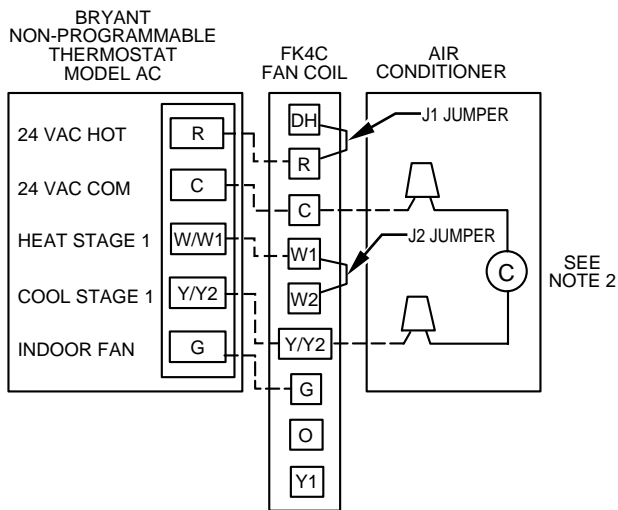

A97363

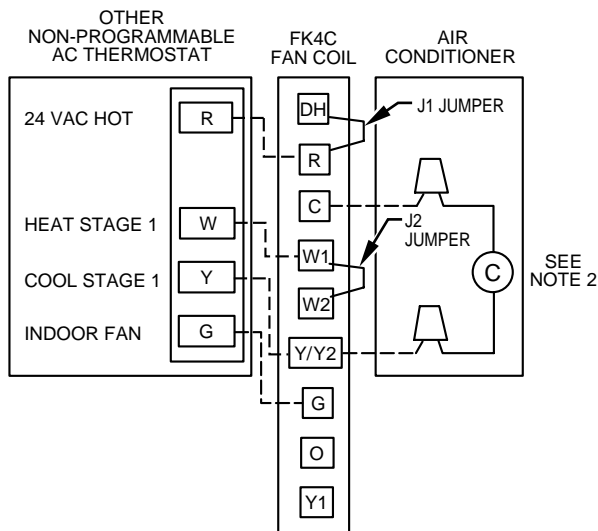

A97365

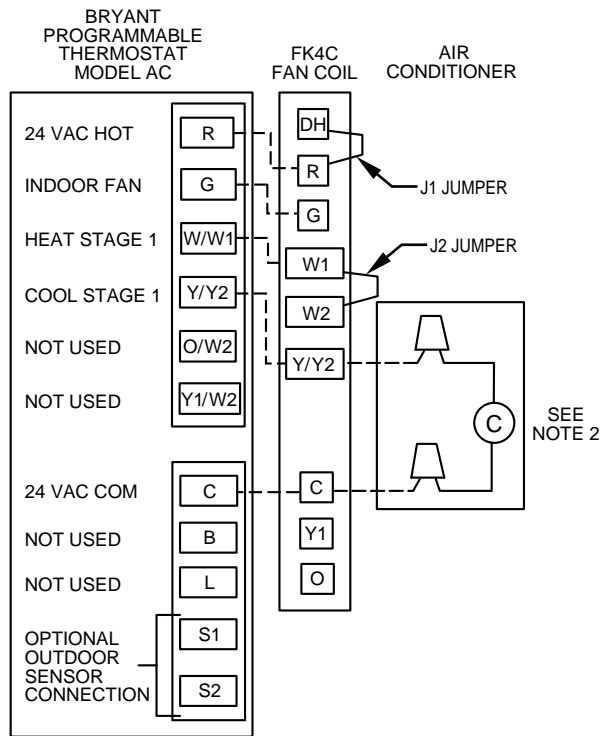

A97364

Fig. 10—Typical 24v Circuit Connections (Continued)

NOTES:

1. BRYANT THERMOSTAT WIRING DIAGRAMS ARE ONLY ACCURATE FOR MODEL NUMBERS TSTAT _____.
2. WIRING MUST CONFORM TO NEC OR LOCAL CODES.
3. SOME UNITS ARE EQUIPPED WITH PRESSURE SWITCH(ES), TEMPERATURE SWITCH, OR 5-MINUTE COMPRESSOR CYCLE PROTECTION. CONNECT 24V FIELD WIRING TO FACTORY-PROVIDED STRIPPED LEADS.
4. A LIQUID-LINE SOLENOID VALVE IS REQUIRED ON SOME UNITS. SEE SPECIFIC UNIT INSTRUCTIONS.
5. THERMOSTATS ARE FACTORY CONFIGURED WITH 5-MINUTE COMPRESSOR CYCLE PROTECTION AND 4 CYCLES PER HOUR LIMIT. SEE THERMOSTAT INSTALLATION INSTRUCTIONS FOR DETAILS.
6. TO STAGE ELECTRIC RESISTANCE HEAT, CONSULT OUTDOOR THERMOSTAT INSTALLATION INSTRUCTIONS.

PURON® (R-410A) QUICK REFERENCE GUIDE

- Puron® refrigerant operates at 50-70 percent higher pressures than R-22. Be sure that servicing equipment and replacement components are designed to operate with Puron®
- Puron® refrigerant cylinders are rose colored.
- Recovery cylinder service pressure rating must be 400 psig, DOT 4BA400 or DOT BW400.
- Puron® systems should be charged with liquid refrigerant. Use a commercial type metering device in the manifold hose when charging into suction line with compressor operating
- Manifold sets should be 700 psig high side and 180 psig low side with 550 psig low-side retard. • Use hoses with 700 psig service pressure rating.
- Leak detectors should be designed to detect HFC refrigerant.
- Puron®, as with other HFCs, is only compatible with POE oils.
- Vacuum pumps will not remove moisture from oil.
- Do not use liquid-line filter driers with rated working pressures less than 600 psig.
- Do not leave Puron® suction line filter driers in line longer than 72 hours.
- Do not install a suction-line filter drier in liquid line.
- POE oils absorb moisture rapidly. Do not expose oil to atmosphere.
- POE Oils may cause damage to certain plastics and roofing materials.
- Wrap all filter driers and service valves with wet cloth when brazing.
- A factory approved liquid-line filter drier is required on every unit.
- Do NOT use an R-22 TXV.
- If indoor unit is equipped with an R-22 TXV, it must be changed to a Puron® TXV.
- Never open system to atmosphere while it is under a vacuum.
- When system must be opened for service, recover refrigerant, evacuate then break vacuum with dry nitrogen and replace filter driers. Evacuate to 500 microns prior to recharging.
- Do not vent Puron® into the atmosphere.
- Do not use capillary tube coils.
- Observe all **warnings**, **cautions**, and **bold** text.

