

**KIT FEATURES**

- ▶ Shaft and DIN unit provisions
- ▶ Incorporates factory climate controls into installation

**KIT COMPONENTS**

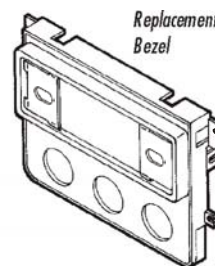

**TOOLS REQUIRED**



Phillips screwdriver



Cutting tool



Adjustable wrench

# 99-3101

## INSTALLATION INSTRUCTIONS

**APPLICATIONS**

| <b>CAR</b>  | <b>PAGE</b> |
|---|-------------|
| <b>CHEVROLET</b>                                  |             |
| Beretta 1988-90<br>(models equipped with AC)..... | 1-2         |
| Corsica 1988-90<br>(models equipped with AC)..... | 1-2         |



## ALL VEHICLES

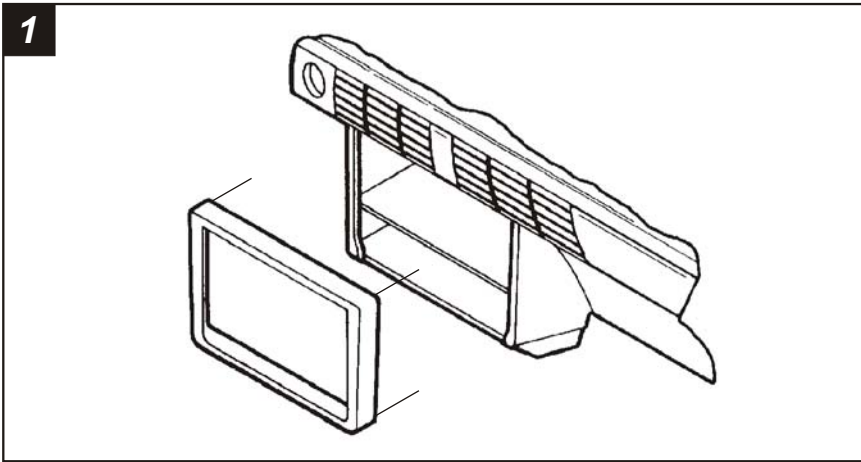

Disconnect the negative battery terminal to prevent an accidental short circuit. Unclip the trim bezel surrounding the factory head unit and climate controls. Remove (4) screws securing the head unit/climate control assembly. Reach under the dash and remove the colored tubing assembly connected to the "mode" control on the climate control panel. Pull the head unit/climate control assembly from the dash and disconnect the wiring. Remove (4) screws securing the factory head unit to the metal bracket housing and remove the unit. Remove (4) screws securing the climate controls to the metal bracket housing and remove the controls.

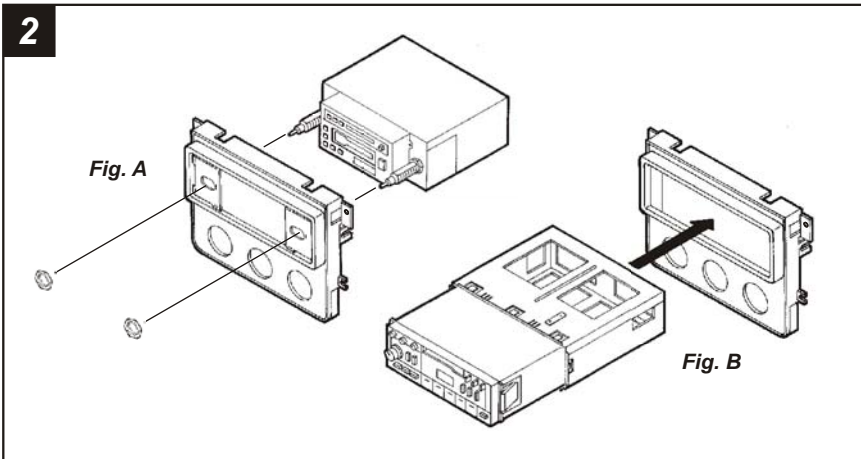

**2-SHAFT HEAD UNITS:** Slide the aftermarket head unit into the kit and secure with shaft nuts. (see Fig. A)

**DIN HEAD UNITS:** Cut and remove the shaft supports from the **Replacement Bezel**. Slide the DIN cage into the kit and secure by bending the metal locking tabs down. Slide the aftermarket head unit into the cage until secure. (see Fig. B)

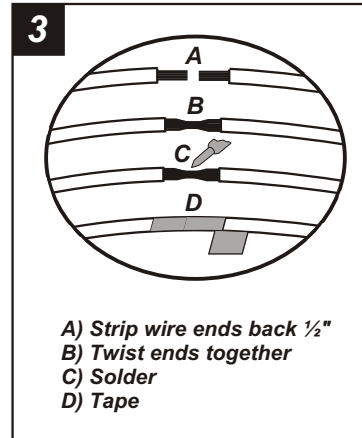

- A) Strip wire ends back 1/2"
- B) Twist ends together
- C) Solder
- D) Tape

Locate the factory wiring harness in the dash. Metra recommends using the proper mating adaptor and making connections as shown. (Isolate and individually tape off the ends of any unused wires to prevent electrical short circuit).

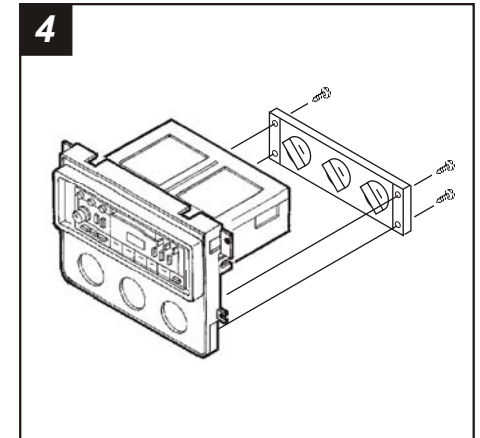

Mount the climate controls to the back of the dash. Metra recommends using the **Replacement Bezel** with (4) screws previously removed in step #1.

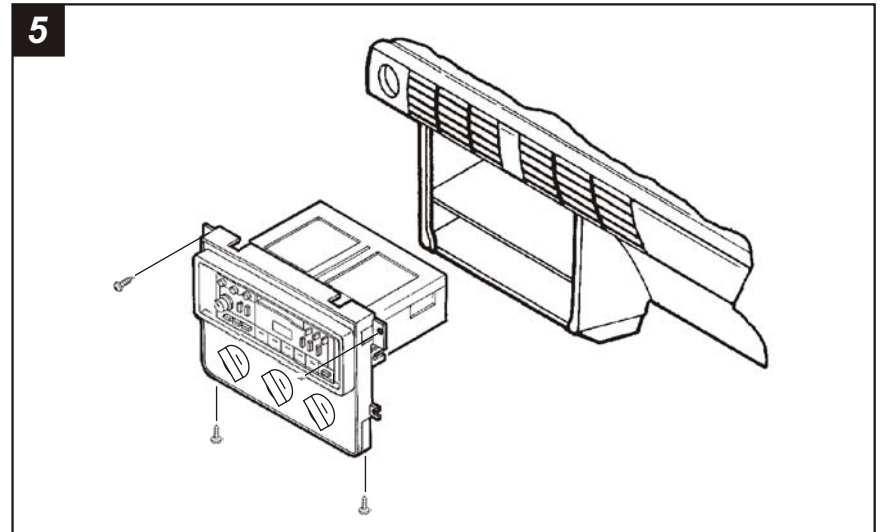

Re-connect the battery terminal and test the unit for proper operation. Mount the head unit/kit assembly to the sub-dash with (4) screws previously removed in step #1.