



Promaster 252z / 260Z / 272Z

Owner/Operator Manual

Models

- 992066 - 25hp 52"
- 992067 - 25hp 60"
- 992068 - 27hp 60"
- 992069 - 28hp 60"
- 992070 - 25hp 72"
- 992071 - 27hp 52"
- 992072 - 27hp 72"

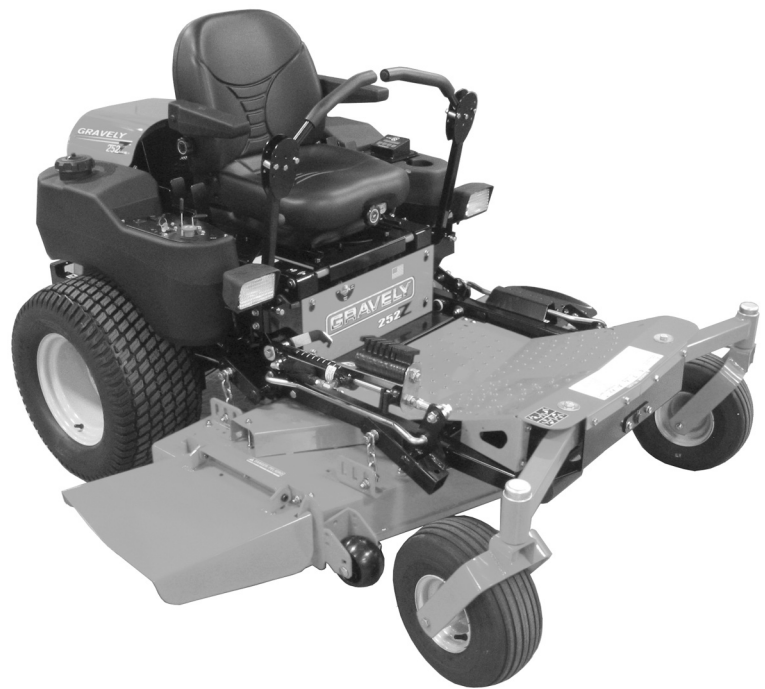

US Patent 6,301,864



(GB) ENGLISH

(F) FRANÇAIS

(E) ESPAÑOL

CONTROLS AND FEATURES

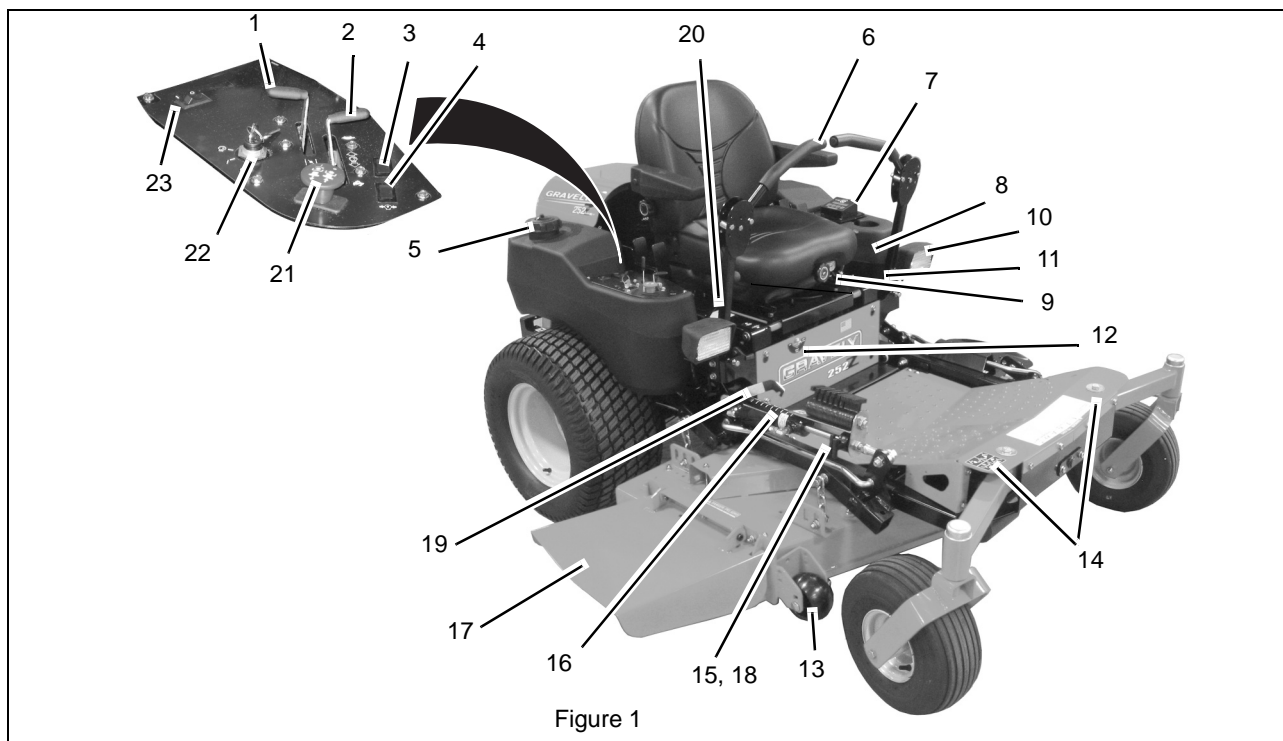

Figure 1

ENGLISH

1. Choke Control (Not on EFI* models)
2. Throttle Lever
3. Malfunction Indicator Light (EFI* models only)
4. Oil Pressure Indicator
5. Fuel Tanks and Caps
6. Steering Levers
7. Eye-Q™
8. Mower Lift Lever
9. Seat Suspension Adjustment Knob
10. Headlight
11. Seat Adjustment Lever
12. Fuel Shut Off Valve
13. Antiscalp Rollers
14. Axle Locks
15. Cylinder Stops
16. Height of Cut Indicator
17. Mower Deck with Chute Deflector
18. Cylinder Stop Storage Post
19. Foot Board Latch
20. Parking Brake
21. Power Take Off (PTO) Switch
22. Ignition Switch
23. Headlight Switch

*Electronic Fuel Injection

FRANÇAIS

1. Starter (indisponible sur les modèles EFI*)
2. Manette des gaz
3. Voyant d'anomalie (modèles EFI* modèles uniquement)
4. Indicateur de pression d'huile
5. Réservoirs de carburant et bouchons
6. Leviers de direction
7. Eye-Q™
8. Levier de relevage de la tondeuse
9. Levier de réglage de la suspension
10. Phare
11. Levier de réglage du siège
12. Robinet de carburant
13. Rouleaux anti-scalp
14. Verrouillage de l'essieu
15. Butées de vérin
16. Indicateur de hauteur de coupe
17. Carter de coupe avec déflecteur
18. Montant de remisage de butées de vérin
19. Attache du repose-pied
20. Frein de stationnement
21. Contacteur de régime de la Pdf
22. Contacteur de démarrage
23. Commande des phares

*Injection électronique

ESPAÑOL

1. Control de aire (no en modelos EFI*)
2. Palanca de ralentí
3. Lámpara indicadora de fallo (solamente modelos EFI*)
4. Indicador de la presión del aceite
5. Tapas y depósitos de combustible
6. Palancas de dirección
7. Eye-Q™
8. Palanca de elevación del cortacésped
9. Palanca de ajuste de la suspensión
10. Luces delanteras
11. Palanca de ajuste del asiento
12. Válvula de cierre de combustible
13. Rodillos antidesbroce
14. Trabas del eje
15. Topes de cilindro
16. Altura del indicador de corte
17. Plataforma de corte
18. Poste de almacenamiento del tope del cilindro
19. Traba de la plataforma de pie
20. Freno de estacionamiento
21. Interruptor de la toma de fuerza (TDF)
22. Interruptor de encendido
23. Interruptor de los faros delanteros

*Inyección electrónica de combustible

⚠ WARNING ⚠

The engine exhaust from this product contains chemicals known to the State of California to cause cancer, birth defects or other reproductive harm.

TABLE OF CONTENTS

Controls and Features	2	Storage	25
Safety	5	Accessories	26
Assembly	10	Troubleshooting	25
Operation	11	Service Parts	26
Maintenance Schedule	14	Specifications	27
Service and Adjustments	17	Warranty	28

INTRODUCTION

THE MANUAL

Before operation of unit, carefully and completely read your manuals. The contents will provide you with an understanding of safety instructions and controls during normal operation and maintenance.

All reference to left, right, front, or rear are given from operator sitting in the operation position and facing the direction of forward travel.

SERVICE AND REPLACEMENT PARTS

Transfer model & serial number label from product registration here.

When ordering publications, replacement parts, or making service inquiries, know the Model and Serial numbers of your unit and engine. Numbers are located on the product registration form in the unit literature package. They are printed on a serial number label, located on the frame of your unit (Figure 2).

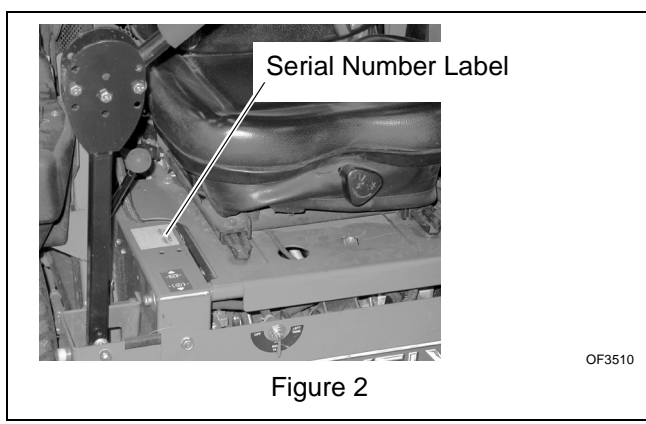

• Record Unit Model and Serial numbers here.

• Record Engine Model and Serial numbers here.

PRODUCT REGISTRATION

The Gravely dealer must register the product at the time of purchase. Registering the product will help the company process warranty claims or contact you with the latest service information. All claims meeting requirements during the limited warranty period will be honored, whether or not the product registration card is returned. Keep a proof of purchase if you do not register your unit.

Customer Note: If Dealer does not register your product, please fill out, sign and return the product registration card to Gravely.

UNAUTHORIZED REPLACEMENT PARTS

Use only Gravely replacement parts. The replacement of any part on this equipment with anything other than a Gravely authorized replacement part may adversely affect the performance, durability, and safety of this unit and may void the warranty. Gravely disclaims liability for any claims or damages, whether regarding warranty, property damage, personal injury or death arising out of the use of unauthorized replacement parts.

NOTE: To locate your nearest Gravely Dealer, call 1-800-472-8359 or go to www.gravely.com on the internet.

DISCLAIMER

Gravely reserves the right to discontinue, change, and improve its products at any time without public notice or obligation to the purchaser. The descriptions and specifications contained in this manual were in effect at printing. Equipment described within this manual may be optional. Some illustrations may not be applicable to your unit.

DEALER DELIVERY

Dealer should:

1. Test brakes after tractor is assembled to be sure adjustment has not been disturbed in shipment (See *Parking Brake Interlock System* on page 11). Wheel brakes are properly adjusted at factory.

2. Check the safety interlock system to make sure that it is functioning properly. With operator on seat, unit must not start unless steering levers are in neutral (N) and Power Takeoff (PTO) is disengaged (Off). Engine must stop if operator leaves seat when steering levers are in any drive position or PTO is engaged (On). See *Safety Interlock System* on page 11.
3. Fill out Original Purchaser Registration Card and return the card to Gravely.
4. Explain Gravely Limited Warranty Policy.
5. Explain recommended lubrication and maintenance. Advise customer on adjustments.

Instruct customer on controls and operation of unit. Discuss and emphasize the Safety Precautions. Give customer Owner/Operator, Parts, and Engine Manuals. Advise customer to thoroughly read and understand them.

Customer Note: Your Dealer has been provided complete set-up and preparation instructions which must be completed prior to you taking delivery of this unit. The dealer is required to review important information in this manual with you before or upon delivery of the unit or attachment.

SAFETY



WARNING: This cutting machine is capable of amputating hands and feet and throwing objects. Failure to observe the safety instructions in the manuals and on decals could result in serious injury or death.

Slopes are a major factor related to loss-of-control and tip-over accidents. Operation on all slopes requires extra caution.

Tragic accidents can occur if the operator is not alert to the presence of children. Never assume that children will remain where you last saw them.

Gasoline is extremely flammable and the vapors are explosive, handle with care.

Disengage attachment, stop unit and engine, remove key, engage parking brake, and allow moving parts to stop before leaving operator's position.



WARNING: POTENTIALLY HAZARDOUS SITUATION! If not avoided, COULD RESULT in death or serious injury.



CAUTION: POTENTIALLY HAZARDOUS SITUATION! If not avoided, MAY RESULT in minor or moderate injury. It may also be used to alert against unsafe practices.

NOTATIONS

NOTE: General reference information for proper operation and maintenance practices.

IMPORTANT: Specific procedures or information required to prevent damage to unit or attachment.

PRACTICES AND LAWS

Practice usual and customary safe working precautions, for the benefit of yourself and others. Understand and follow all safety messages. Be alert to unsafe conditions and the possibility of minor, moderate, or serious injury or death. Learn applicable rules and laws in your area, including those that may restrict the age of the operator.

REQUIRED OPERATOR TRAINING

Original purchaser of this unit was instructed by the seller on safe and proper operation. If unit is to be used by someone other than original purchaser (loaned, rented or sold), ALWAYS provide this manual and any needed safety training before operation.



SAFETY ALERT SYMBOL

These are safety alert symbols. They mean:

- ATTENTION!
- YOUR SAFETY IS INVOLVED!



When you see this symbol:

- BECOME ALERT!
- OBEY THE MESSAGE!

SIGNAL WORDS

The safety alert symbols above and signal words below are used on decals and in this manual.

Read and understand all safety messages.



DANGER: IMMINENTLY HAZARDOUS SITUATION! If not avoided, WILL RESULT in death or serious injury.

SAFETY DECALS AND LOCATIONS

ALWAYS replace missing or damaged Safety Decals.
Refer to Figure 3 for Safety Decal locations.

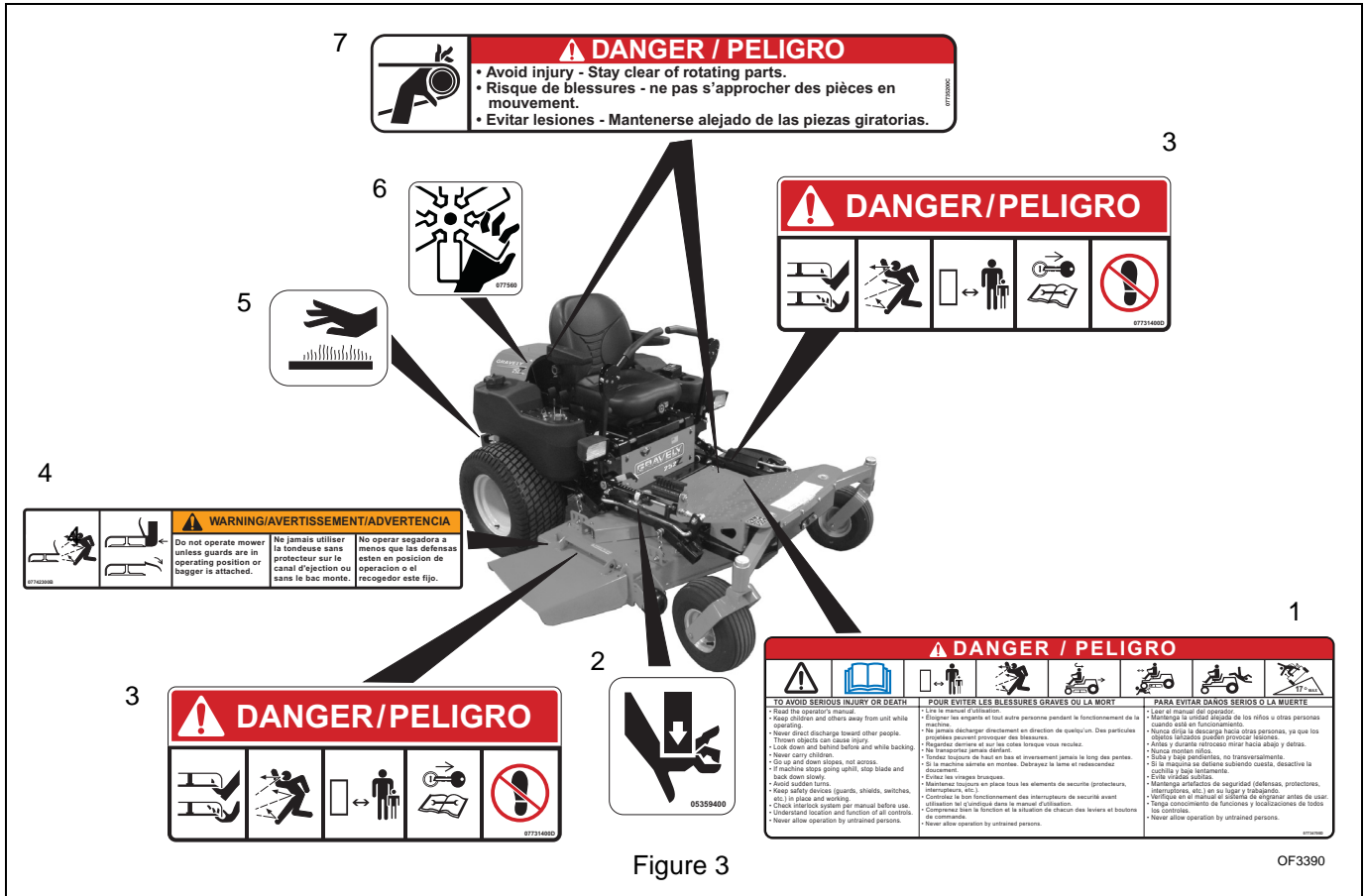

Figure 3

OF3390

1. DANGER! TO AVOID SERIOUS INJURY OR DEATH



OL1801

Read Owner/Operator Manual.



OL4370

Keep children and others away from unit while operating.



OL0910

Never direct discharge toward other people. Thrown objects can cause injury. Remove objects that could be thrown by the blade.



OL4460

Look down and behind before and while backing.



OL4470

Keep children out of work area and under watchful care of a responsible adult.



OL4480

NEVER CARRY CHILDREN.

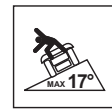

OL4450

Go up and down slopes, not across.
DO NOT operate on slopes over 17°.

- If machine stops going uphill, stop blade and back down slowly.
- Avoid sudden turns.
- Keep safety devices (guards, shields, switches, etc.) in place and working.
- Check interlock system per manual before use.
- Understand location and function of all controls.
- Never allow operation by untrained persons.

2. PINCH POINT



OF3330

Avoid pinch points.

3. DANGER! ROTATING PARTS



OL3030

Always keep feet and hands away from rotating parts.



OL0910

Always stand clear of discharge area. Do not direct discharge toward other people.

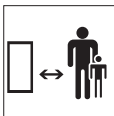

OL3292

Keep people away from unit while operating.



OL4010

Shut off engine, remove key, read manual before you adjust or repair unit.



OL4420

NO STEP! Always keep feet away from rotating parts.

4. WARNING!



OL4430

Always stand clear of discharge area.

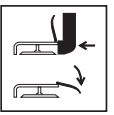

OL3320

Do not operate mower unless bagger is attached or guards are in operating position.

5. HOT SURFACES!



OS0731

DO NOT touch parts which are hot from operation. **ALWAYS** allow parts to cool.

6. ROTATING PARTS



OF3450

AVOID INJURY. Stay clear of rotating parts.

7. DANGER!



OL4730

AVOID INJURY. Stay clear of rotating parts.

SAFETY RULES

Read, understand, and follow all safety practices in Owner/Operator Manual before beginning assembly. Failure to follow instructions could result in personal injury and/or damage to unit.

ALWAYS remove key and/or wire from spark plug before assembly. Unintentional engine start up can cause death or serious injury.

Complete a walk around inspection of unit and work area to understand:

- Work area
- Your unit
- All safety decals

ALWAYS check overhead and side clearances carefully before operation. **ALWAYS** be aware of traffic when operating along streets or curbs.

Keep children and people away.

Keep children out of work area and under watchful care of a responsible adult.

Keep area of operation clear of all toys, pets, and debris. Thrown objects can cause injury.

Check for weak spots on docks, ramps or floors. Avoid uneven work areas and rough terrain. Stay alert for hidden hazards or traffic.

DO NOT operate near drop offs, ditches, or embankments. Unit can suddenly turn over if a wheel is over the edge of a cliff or ditch, or if an edge caves in.

Data indicates that operators, age 60 and above, are involved in a larger percentage of riding mower related injuries. These operators should evaluate their ability to operate the riding mower safely enough to protect themselves and others from serious injury.

Read the entire Owner/Operator manual and other training material. If the operator or the mechanic cannot read the manual, it is the owner's responsibility to explain it to them. Only the user can prevent and is responsible for accidents or injuries occurring to themselves, other people or property.

Only trained adults may operate or service unit.

Local regulations may restrict the age of the operator.

Training includes actual operation.

NEVER allow children to operate or play on or near unit. Be alert and shut off unit if children enter area.

NEVER operate unit after or during the use of medication, drugs or alcohol. Safe operation requires your complete and unimpaired attention at all times.

DO NOT wear loose clothing or jewelry and tie back hair that may get caught in rotating parts.

Wear adequate outer garments.

NEVER wear open sandals or canvas shoes during operation. Wear adequate safety gear, protective gloves and footwear.

Wear proper footwear to improve footing on slippery surfaces.

Always wear safety goggles or safety glasses with side shields when operating mower.

Moving parts can cut or amputate fingers or a hand. Wrap blade(s) or wear gloves to service. On multiblade mowers, rotation of one blade will cause all blades to rotate.

NEVER place your hands or any part of your body or clothing inside or near any moving part while unit is running.

ALWAYS keep hands and feet away from all rotating parts during operation. Rotating parts can cut off body parts.

ALWAYS keep body and hands away from pin holes or nozzles which eject hydraulic fluid under pressure.

DO NOT touch parts which are hot. Allow parts to cool.

ALWAYS keep hands and feet away from all pinch points.

Fumes from the engine exhaust can cause death or serious injury. DO NOT run engine in an enclosed area. Always provide good ventilation.

Read, understand, and follow all instructions in the manual and on the machine before starting.

Understand:

- How to operate all controls
- The functions of all controls
- How to STOP in an Emergency
- Braking and steering characteristics
- Turning radius and clearances

Keep safety devices or guards in place and functioning properly. NEVER modify or remove safety devices.

Ensure Safety Interlock System is functioning properly. DO NOT operate unit if safety interlock is damaged or disabled.

Start and operate unit only when seated in operator's position. Steering control levers must be in neutral, PTO disengaged and parking brake set when starting engine.

Use care when approaching blind corners, shrubs, trees or other objects that may obscure vision.

Dust, smoke, fog, etc. can reduce vision and cause an accident. Mow only in daylight or good artificial light.

Avoid slippery surfaces. Always be sure of your footing.

DO NOT mow on wet grass. Reduced traction could cause sliding and effect the machine's stability.

Watch for traffic when operating near or crossing roadways.

Never carry passengers.

DO NOT try to stabilize the machine by putting your foot on the ground.

Never direct discharge towards persons or property that may be injured or damaged by thrown objects. Use extreme caution on gravel surfaces.

Always stand clear of the discharge area.

ALWAYS disengage PTO, stop unit and engine, remove key, engage parking brake and allow moving parts to stop before leaving operator's position.

Never engage PTO while raising attachment or when attachment is in raised position.

DO NOT operate at too fast a rate. DO NOT change engine governor settings or over-speed engine. Slow down before turning.

DO NOT operate in reverse unless absolutely necessary. ALWAYS look down and behind before and while backing.

If equipment vibrates abnormally, stop engine at once, wait for moving parts to stop and remove wire from spark plug. Repair any damage before restarting unit.

Take all possible precautions when leaving unit unattended. Shut off engine. Remove wire from spark plug and secure it away from spark plug.

ALWAYS remove key to prevent unauthorized use.

Know the weight of loads. Limit loads to those you can safely control and the unit can safely handle.

Disengage PTO when attachment is not in use. ALWAYS turn off power to attachment when travelling, crossing driveways, etc.

Mow up and down slopes, not across them.

DO NOT operate on slopes of more than 17 degrees.

Use of a Rollover Protection System (ROPS) is recommended for slope operation. See *Accessories* on page 26.

Always wear a seat belt when operating unit using a Rollover Protection System (ROPS).

Keep all movements on the slope *slow* and *gradual*. Do not make sudden changes in speed or direction.

Avoid starting or stopping on the slope. If tires lose traction, disengage the blades and proceed slowly *straight* down the slope.

If you cannot back up a slope or you feel uneasy on it, do not mow it.

DO NOT park on slopes unless necessary. When parking on slope always chock or block wheels. Always engage parking brake.

Use a slow speed. Tires may lose traction on slopes even though the brakes are functioning properly.

Do not bypass transmission when on a slope.

Use extra care when loading or unloading unit onto trailer or truck.

Secure unit chassis to transport vehicle. NEVER secure from rods or linkages that could be damaged.

DO NOT transport machine while engine is running.

ALWAYS turn off power to attachment when transporting.

Keep unit free of debris. Clean up oil or fuel spills.

This product is equipped with an internal combustion type engine. DO NOT use unit on or near any unimproved, forest-covered or brush covered land unless exhaust system is equipped with a spark arrester meeting applicable local, state or federal laws. A spark arrester, if it is used, must be maintained in effective working order by operator.

Fuel is highly flammable and its vapors are explosive. Handle with care. Use an approved fuel container.

NO smoking, NO sparks, NO flames. ALWAYS allow engine to cool before servicing.

NEVER fill fuel tank when engine is running or hot from operation.

NEVER fill or drain fuel tank indoors.

Replace fuel cap securely and clean up spilled fuel.

Never fill containers inside a vehicle or on a truck or trailer bed with a plastic liner. Always place containers on the ground away from your vehicle before filling.

When practical, remove gas-powered equipment from the truck or trailer and refuel it on the ground. If this is not possible, then refuel such equipment on a trailer with a portable container, rather than from a gasoline dispenser nozzle.

Keep the nozzle in contact with the rim of the fuel tank or container opening at all times until fuelling is complete. Do not use a nozzle lock-open device.

If fuel is spilled on clothing, change clothing immediately.

Avoid Electric Shock. Objects contacting both battery terminals at the same time may result in injury and unit damage. DO NOT reverse battery connections.

Explosive Gases from battery can cause death or serious injury. Poisonous battery fluid contains sulfuric acid and its contact with skin, eyes or clothing can cause severe chemical burns.

No flames, No sparks, No smoking near battery.

ALWAYS wear safety glasses and protective gear near battery.

DO NOT TIP battery beyond a 45° angle in any direction.

ALWAYS keep batteries out of reach of children.

Battery posts, terminals and related accessories contain lead and lead compounds, chemicals known to the State of California to cause cancer and reproductive harm. Wash hands after handling.

ALWAYS block wheels and know all jack stands are strong and secure and will hold weight of unit during maintenance.

Release pressure slowly from components with stored energy.

Keep nuts and bolts tight, especially blade attachment bolts, and keep equipment in good condition.

NEVER attempt to make any adjustments to unit while engine is running (except where specifically recommended). Stop engine, remove key or spark plug wire and wait for all moving parts to stop before servicing or cleaning.

Check parking brake operation frequently. Adjust and service as required.

ALWAYS maintain unit in safe operating condition. Damaged or worn out muffler can cause fire or explosion.

NO smoking, NO sparks, NO flames. ALWAYS allow engine to cool before servicing.

Maintain or replace safety and instructions labels, as necessary.

NEVER store unit with fuel in fuel tank, inside a building where any ignition sources are present.

Shut off fuel and allow engine to cool completely before storing in closed area or covering unit.

Clean grass and debris from unit, especially from around muffler and engine, to help prevent fires.

For extended storage, shut off fuel and clean unit thoroughly. See engine manual for proper storage.

Lower cutting deck unless a positive mechanical lock is used.

Use only attachments or accessories designed for your unit.

Check attachment components frequently. If worn or damaged, replace with manufacturer's recommended parts.

ASSEMBLY



WARNING: AVOID INJURY. Read and understand entire *Safety* section before proceeding.

UNIT ASSEMBLY

Package Contents:

Unit, Mower Deck and Literature Pack

Preparation Checklist

Refer to the Owner/Operator manual as required.

1. Unpack Unit - Remove shrink wrap and packaging materials.
2. Remove Unit From Container - Open Bypass Valves (dump valves) (See *Moving the Unit with the Engine Off* on page 14).
Push unit from container onto a level surface. Close the dump valves.
3. Tires - Adjust tire pressure for front tires: 20-25 PSI (138-172 kN/m²), rear tires: 12-15 PSI (83-103 kN/m²).
4. Position and Attach Seat - Remove nuts from seat studs in hood frame. Lift and rotate seat onto hood frame. Secure with nuts.
5. Position Steering Levers - Remove bolts and spacers from steering rod. Flip the steering levers into operating position. Reinstall spacers, bolts and nuts. Tighten hardware securely. See Figure 4.

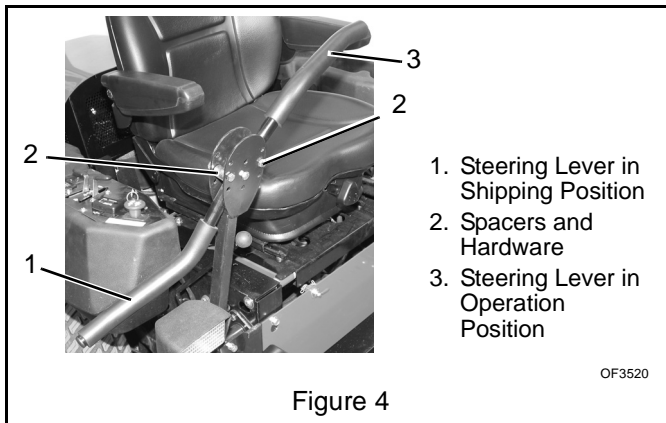

6. Battery - Remove battery from unit and charge (See *Battery* on page 19).
7. Check Engine Crankcase - To access engine, open hood. Check and add oil if needed. See Engine Manual for specifications.
8. 60" and 72" Decks - Remove, reverse, and reinstall discharge chute and mounting bracket.



WARNING: Discharge chute must pivot freely. DO NOT overtighten the pivot bolts.

9. Fill Engine Fuel Tank - Add clean fuel to the fuel tank.

IMPORTANT: Refer to Engine Manual for fuel type.

10. Hardware - Check for loose hardware.
11. Check Safety Interlock System - Check to see that the interlock system operates correctly (See *Safety Interlock System* on page 11).



WARNING: FAILURE OF INTERLOCK together with improper operation can result in severe personal injury.

12. Lubrication - Lubricate all fittings per maintenance label under seat and check hydrostat oil level (See *Lubricate Unit* on page 20).
13. Level Deck - Check unit to assure deck level set at factory has been maintained (See *Leveling the Mower Deck* on page 24).
14. Check Function of all Controls - Ensure unit runs and performs properly.



WARNING: FAILURE OF CONTROLS could result in death or serious injury.

OPERATION



WARNING: AVOID INJURY. Read and understand entire *Safety* section before proceeding.

CONTROLS AND FEATURES

See Figure 1 for Controls and Features locations.

Safety Interlock System



WARNING: Safety interlock system failure and improper operation of unit can result in death or serious injury. Test this system each time the unit is operated. If this system does not function as described, do not operate until repairs are made.

Perform the following tests to ensure the safety interlock system is working properly. If the unit does not perform as stated, contact your Gravely dealer for repairs.

NOTE: When the parking brake is engaged, the steering levers are locked in neutral.

Test	Steering Levers	PTO	Parking Brake	Engine
STARTING INTERLOCK				
1	Neutral	Off	Engaged	Starts
2	Neutral	On	Engaged	Doesn't Start
3	Neutral	Off	Disengaged	Doesn't Start
OPERATING INTERLOCK (ENGINE ON)				
4*	Neutral	On	Engaged	Shuts Off
5*	Neutral	Off	Disengaged	Shuts Off

* Operator lifts off seat.

Parking Brake Interlock System

With the parking brake engaged, the steering levers must be locked in neutral.

With the parking brake disengaged, the engine must not start and the engine must shut off if the operator leaves the seat.

Eye-Q™



Monitors equipment performance, operator performance, and equipment maintenance. See Eye-Q Owner's Manual for how to access these features.

Steering Levers

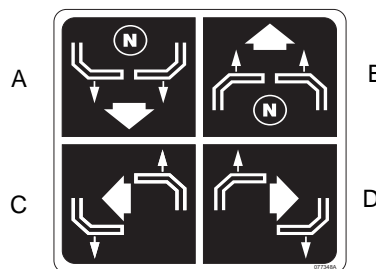

The steering levers control speed and direction. In addition, they will stop the unit.

- A. For reverse travel, pull both steering control levers backward.
- B. For straight forward travel, push both steering control levers forward.
- C. To turn left, pull the left back or push the right steering control lever forward or a combination of both.
- D. To turn right, pull the right back or push the left steering control lever forward or a combination of both.

To stop, return both steering levers to neutral.

NOTE: The steering controls are mechanically locked in neutral whenever the parking brake is engaged.

NOTE: Aggressive turning can scuff or damage lawns. ALWAYS keep both wheels rotating when making sharp turns. DO NOT make turns with inside wheel completely stopped. To obtain minimum turning radius, slowly reverse inside wheel while moving outside wheel slowly forward.

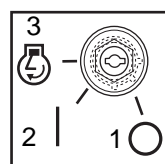

OF1751

Ignition Switch

Operate the ignition switch with the removable key. The switch has three positions: Off (1), On (2) and Start (3). To start the engine, turn the key to Start, then release to On. To stop the engine, turn the key to Off.

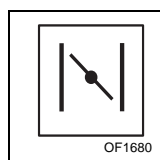

OF1680

Choke Control (Not on EFI models)

Push the choke lever forward to start a cold engine. Pull the choke lever to the rear when the engine gets warm.



Throttle Lever

The throttle lever changes the engine speed. Move the throttle lever to Fast (1) to increase engine speed. Move the lever to Slow (2) to decrease engine speed.

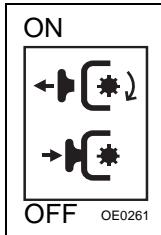

Power Take Off (PTO) Switch

Power take off (PTO) switch engages and disengages the mower blades.

Pull the power take off (PTO) switch to "On" position to engage mower blades.

Push the power take off (PTO) switch to "Off" position to disengage mower blades.

NOTE: The engine will not start unless the steering control levers are in the neutral position, the PTO switch is in the "Off" position and parking brake is engaged.

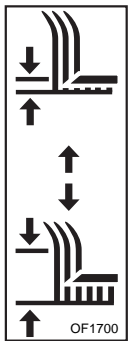

Mower Lift Lever

Use the mower lift lever, located on the left side of tractor, to raise and lower the mower deck.

Pull the lever rearward to raise or push the lever forward to lower the mower deck.

Release lever to hold the mower deck in selected position.

The cutting height indicator on the right lift cylinder shows the approximate cutting

height in inches.

Cylinder Stops

The cylinder stops ensure the same cutting height after raising the deck to clear an obstacle. Store the stops on the post behind the hydraulic lift cylinder. The stops come in two (2) sizes, 1/4" (.64 cm) and 1/2" (1.27 cm).

1. Remove the cylinder stops from the post and snap onto the lift cylinder rod.
2. Push the lift lever forward until the cylinder rests against the cylinder stops.

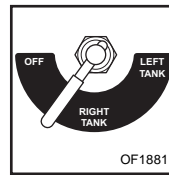

Fuel Shut-Off Valve

Use this valve to control fuel flow from left or right fuel tank.

Open the valve to operate the engine. Turn the valve to "Off" when storing or transporting the unit.

NOTE: Fuel shut-off valve on EFI units does not have an "Off" position.

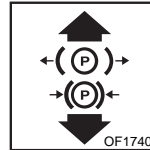

Parking Brake Lever

1. Pull lever up to engage parking brake.
2. Push lever down to disengage parking brake.

Seat Adjustments



WARNING: Make all seat adjustments with unit stationary, parking brake engaged and engine shut off.

To adjust seat forward or backward:

1. While seated, pull seat adjustment lever outward and slide seat into desired position.
2. Release lever and slide seat forward or back to lock seat into position.

To adjust seat suspension:

- To make seat more firm turn knob clockwise. To make seat less firm turn knob counter clockwise. Turn knob several turns at a time until desired position is achieved.

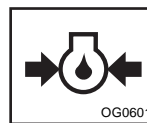

Engine Oil Pressure Indicator

Indicator lights up "Red" if the oil pressure is low. Check oil level and add if necessary. Refer to engine manual.

Malfunction Indicator Light (EFI models only)



The malfunction indicator light flashes when there is a problem with the electronic fuel injection system. When indicator light flashes, disengage PTO,

shut off engine, remove key and see engine manual.

Axle Locks

For a solid front axle, install axle locks on front axle. For a pivoting front axle, remove axle locks from front axle and store on unit.

Headlights

Push headlight switch to ON position to turn ON headlights. Push headlight switch to OFF position to turn OFF headlights.

FILLING FUEL TANK



WARNING: AVOID INJURY. Read and understand entire *Safety* section before proceeding.

Add fuel to Fuel Tank as needed. See your Engine Manual for correct type and grade of fuel.

To add fuel to the fuel tank:

1. Place unit in an open or well-ventilated open area.
2. Stop the engine.
3. Clean the fuel cap and the area around the fuel cap to prevent dirt from entering the fuel tank. Remove the cap from the fuel tank.
4. Fill the fuel tank to within 1" (25 mm) below bottom of filler neck.
5. Replace fuel cap and tighten.
6. Clean up any spilled fuel.

PRE-START



CAUTION: Make sure all hardware is tight, all safety devices are in place and all adjustments are made correctly.

1. Check Safety Interlock System

If this system does not function as described do not operate until repairs are made.

2. Check Air Cleaner

Check air filter for dirt. Clean as required. See Maintenance Section.

3. Check Engine Fuel and Crankcase Oil

Check and add fuel if required. Check that engine crankcase oil is full. Refer to Maintenance Section.

4. Check Tire Pressure

5. Check Hydraulic Fluid Level

6. Adjust Seat

Be sure all controls can be reached safely from operator's position.

STOPPING IN AN EMERGENCY

The unit can be stopped immediately at any time by turning the ignition key to the "Off" position.

STARTING AND SHUT OFF



CAUTION: Read entire Owner/Operator Manual, Clutch Manual, and Engine Manual first.

DO NOT attempt to start engine at this time.

To start the engine:

1. Make sure the steering levers are in neutral.
2. Put the PTO switch in the "Off" position.
3. Engage parking brake.
4. For models with choke:
If the engine is cold, move the choke control to the "On" position. If the engine is warm or hot, do not use choke.
5. Move the throttle to 3/4 "Fast" position. See Engine Manual for detailed instructions.
6. Put the ignition key in the switch and turn it to the "Start" position.
7. As soon as the engine starts, release the key.
8. For models with choke:
Move the choke control to the "Off" position from the "Choke" position. Wait until the engine is running smoothly before operation.

To stop the engine:

1. Bring the steering levers to neutral. Disengage the PTO and engage the parking brake.
2. Move the throttle lever to the "Slow" position.
3. Turn the ignition key to the "Off" position.

TO MOW WITH UNIT

Operate the unit only when seated in the operator's position.

1. Start the engine. Let the engine warm until it is running smoothly.
2. Release parking brake.



WARNING: Move the steering control levers slowly and keep the throttle control lever at slow speed until you learn how to operate the unit.

3. Bring the steering levers to neutral.
4. Slow the engine down to about 3/4 speed.
5. Turn ON the PTO switch to engage the mower.

IMPORTANT: Never engage the PTO if the mower is plugged with grass or other material. This may cause damage to the electric clutch.

6. Move throttle control to fast.
7. Move the steering levers forward to obtain a slow ground speed.
8. To disengage the mower, move the PTO switch to the "Off" position.
9. When you know how to operate the unit, select a speed appropriate to your mowing conditions.

PARKING

To park the unit:

1. Bring the steering levers to neutral. Turn off PTO.
2. Move the throttle lever to the "Slow" position.
3. Engage the parking brake.

4. Lower the attachment.
5. Turn the ignition key to the "Off" position and remove the key.

MOVING THE UNIT WITH THE ENGINE OFF

IMPORTANT: Never tow unit.

1. Shut OFF engine.
2. Place seat in the service position. See *Service Positions* on page 17.
3. Turn right and left bypass valve levers counter clockwise 1/2 turn (Figure 5).



WARNING: Do not bypass transmission when on a slope.

4. Disengage parking brake.
5. Push unit to desired location.
6. Engage parking brake.
7. Turn bypass valve levers clockwise 1/2 turn.

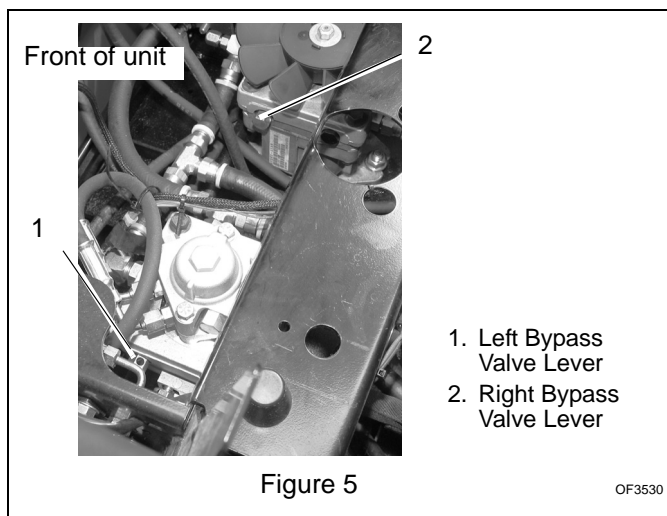

Figure 5

OF3530

FOR BEST PERFORMANCE

- Cut grass when it is dry.
- Keep mower blades sharp.
- Keep mower deck properly leveled.
- Adjust anti-scalp rollers to prevent scalping.
- Do not set height of cut too low. For very tall grass, mow twice.
- Do not travel too fast.
- Mow with the engine set at full throttle.
- When mulching, only remove 1/3 of grass length per cutting.
- Discharge clippings into areas already cut.
- Vary cutting pattern with each mowing.
- Do not allow grass or debris to collect inside of mower deck. Clean after each use.

MAINTENANCE SCHEDULE



WARNING: AVOID INJURY. Read and understand entire *Safety* section before proceeding.

Proper maintenance can prolong the life of unit. The following charts show the recommended service schedule. More frequent service may be required due to working conditions (heavy loads, high ambient temperatures, dusty conditions, or airborne debris).

See the maintenance instructions in the Engine Manual for additional information.

NOTE: Use Figure 6 for maintenance item locations.

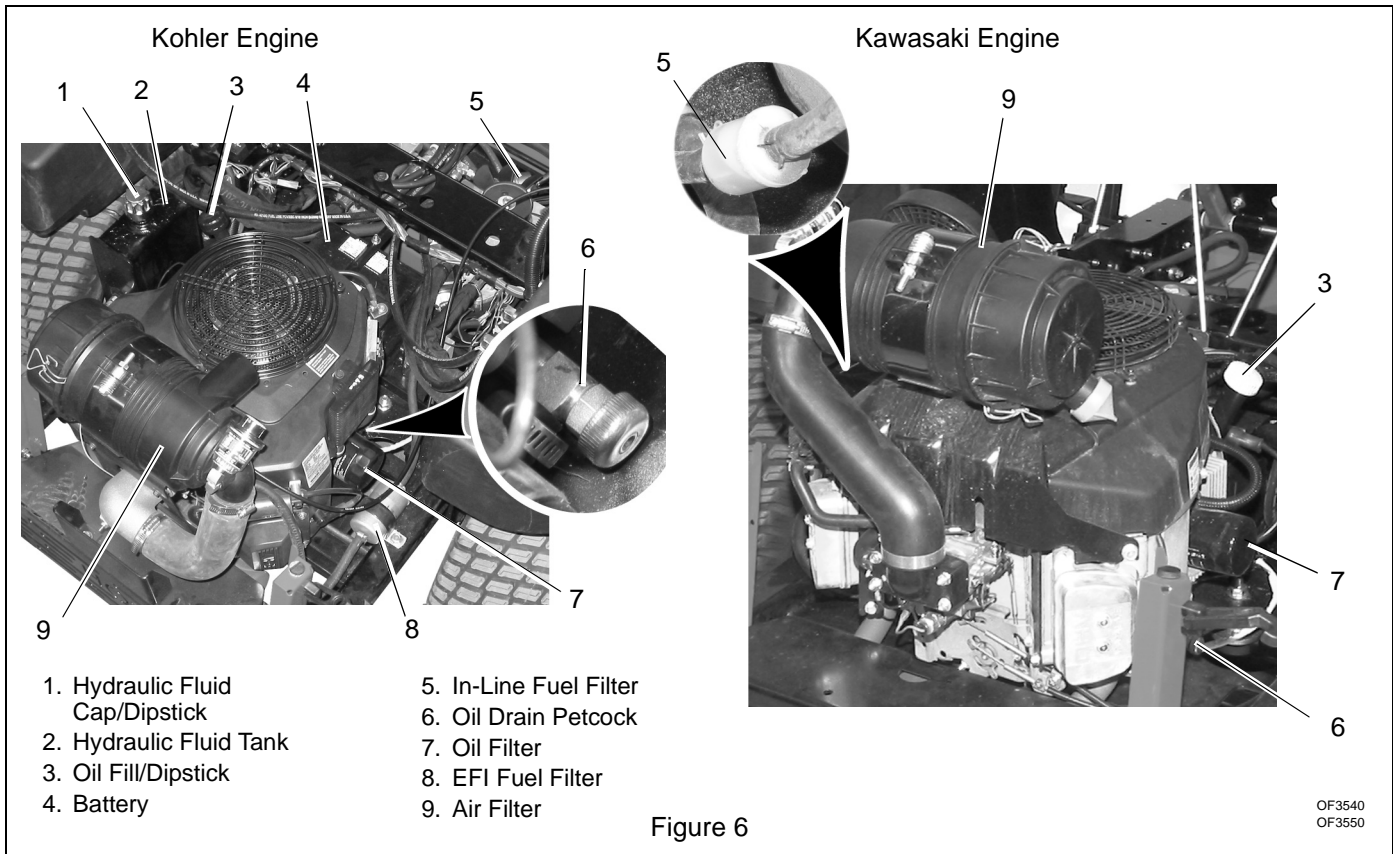

Figure 6

Period	Service	Task
Each Use	Check Safety Interlock	WARNING: Safety interlock system failure and improper operation of unit can result in death or serious injury. Test this system each time the unit is operated. If this system does not function as described, do not operate until repairs are made. See <i>Safety Interlock System</i> on page 11.
	Check Parking Brake Interlock System	See <i>Parking Brake Interlock System</i> on page 11.
	Check Engine Oil	Check oil level on dipstick (item 3). Add more oil through the engine oil fill cap if needed. See engine manual for detailed instructions.
	Check Air Filter	Check the air cleaner element (item 9) before each use. See engine manual for detailed instructions.
	Check Hydraulic Fluid	Check hydraulic oil level mark on cap/dipstick (item 1). Add 15W50 Synthetic oil as needed. Do not overfill. See <i>Hydraulic Fluid</i> on page 17.
Every 25 Hours	Check Tires	See <i>Specifications</i> on page 27 for correct tire pressure.
	Check Mower Blades	Check mower blades for wear. Sharpen or replace as needed. See <i>Mower Blades</i> on page 18.
Every 50 Hours	Clean Air Filter Outer Element (992066, 067, 070)	Clean the outer filter element (item 9). Replace as needed. Refer to engine manual for detailed instructions.
	Lubricate Unit	Oil all pivot points and pin connections. Grease lube fittings. See <i>Lubricate Unit</i> on page 20.

Period	Service	Task
Every 100 Hours	Clean Battery	Keep battery (item 4) and its terminals clean. See <i>Clean Battery</i> on page 19.
	Change Engine Oil	Drain oil by opening oil drain petcock (item 6) on right side of unit. Refer to engine manual for detailed instructions.
	Clean Air Filter Inner Element (992066, 067, 070)	Clean the inner filter element (item 9).
	Check Fasteners	Check mower blade mounting hardware and all other fasteners. Replace missing or damaged fasteners. Tighten all nuts and bolts to their correct torque value.
	Check Belts	Replace worn or deteriorated belts. See <i>Replacing Mower Belts</i> on page 22 and <i>Replacing the Hydro Pump Belt</i> on page 23.
	Change Fuel Filter	Change in-line fuel filter (item 5). Refer to engine manual for detailed instructions.
Every 200 Hours	Change Oil Filter	Change oil filter (item 7). Refer to engine manual for detailed instructions.
	Replace Air Filter Inner Element (992066, 067, 070)	Replace the inner filter element (item 9). Refer to engine manual for detailed instructions.
Every 250 Hours	Replace Air Filter Outer Element (992068, 069, 071, 072)	Replace the outer filter element (item 9). Refer to engine manual for detailed instructions.
Every 500 Hours	Change Hydraulic Fluid and Filter	Drain hydraulic fluid tank (item 2), replace hydraulic oil filter, refill system. See <i>Change Hydraulic Fluid and Filter</i> on page 18.
	Replace Air Filter Inner Element (992068, 069, 071, 072)	Replace the inner filter element (item 9). Refer to engine manual for detailed instructions.
Every 1,500 Hours	Change EFI Fuel Filter (992069 only)	Replace canister fuel filter (item 8) on frame. Refer to engine manual for detailed instructions.

SERVICE AND ADJUSTMENTS

Gravely Dealers will provide any service which may be required to keep your unit operating at peak efficiency. Should engine service be required, it can be obtained from a Gravely Dealer or the engine manufacturer's authorized service center.



WARNING: AVOID INJURY. Read and understand entire *Safety* section before proceeding.



CAUTION: HOT SURFACES may result in injury. DO NOT touch engine or drive parts which are hot from operation. Allow parts to cool before servicing.

SERVICE POSITIONS

1. Place unit on a flat level surface. ALWAYS stop engine. Ensure unit is secure and will not tip over. Strap and clamp onto lift if used.
2. Place steering levers in neutral position and engage parking brake.
3. Unhook hood latches.
4. Firmly grasp engine frame and cover. Lift to desired service position (Figure 7).



CAUTION: WHEN OPENING ENGINE COVER, USE CARE TO PROPERLY ENGAGE PROP INTO SLOT. Be sure footing is secure to accommodate weight shift of hood when rotating to full service position.

Daily Service Position: Place engine hood prop rod into service slot. Assure rod is engaged in slot properly.

Full Service Position: Slowly release frame after seat contacts foot board. Use care and be sure of your footing. Do not step on mower deck.

5. When service is complete, lower hood and secure with latches.

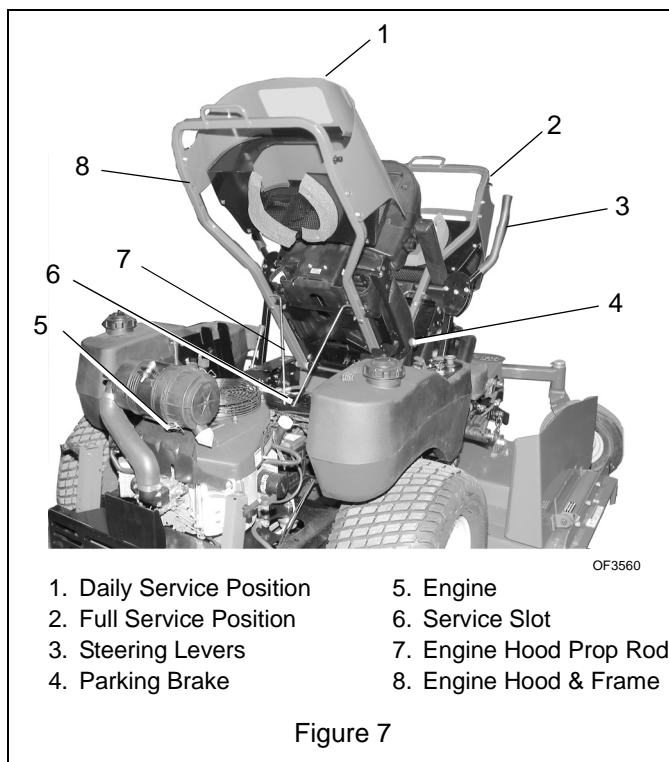

Figure 7

HYDRAULIC FLUID



WARNING: HYDRAULIC FLUID can result in severe burns. Fluid in hydraulic system can penetrate skin and result in serious injury or death.

Be sure to stop the engine before doing any work on hydraulic parts.

Keep body and hands away from pin holes or nozzles which expel hydraulic fluid when under pressure. Use paper or cardboard, not hands, to search for leaks.

Ensure all hydraulic fluid connections are tight and all hydraulic hoses and lines are in good condition before applying pressure to system.

FOREIGN FLUID INJECTED INTO BODY can result in gangrene. Fluid must be surgically removed within a few hours by a doctor familiar with this form of injury.

Check Hydraulic Fluid Level

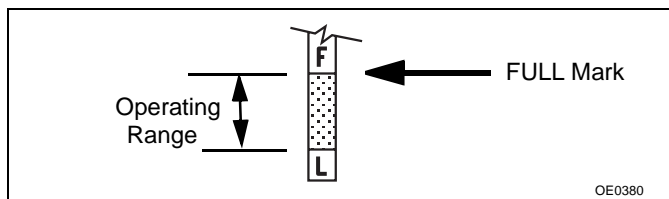

1. Shut OFF engine. Engage parking brake. Remove the ignition key.

2. Put seat in service position.
3. Remove any dirt that may be around the cap/dipstick on the hydraulic reservoir.
4. Remove cap/dipstick.
5. Check hydraulic oil level mark on cap/dipstick.
6. Add 15W50 Synthetic oil as needed. Do not overfill.

Change Hydraulic Fluid and Filter

Change the hydraulic oil filter and hydraulic oil every 500 hours. Use Mobil 15W50 synthetic oil for best component life.

1. Clean around dipstick cap and dipstick. Remove dipstick.
2. Place container under oil filter to catch oil.
3. Remove oil filter.
4. Allow tank to drain.
5. Lubricate rubber gasket on new oil filter with clean hydraulic oil.
6. Spin new oil filter onto filter housing until it makes contact. Tighten oil filter another 1/2 turn.
7. Add new oil to the oil tank. It will take about 4 quarts. Use Mobil 15W50 synthetic oil for best pump and wheel motor life.
8. Properly dispose of waste oil.

MOWER BLADES

Remove



CAUTION: Use sturdy gloves or padding to protect hands when working with mower blades.

1. Turn the engine off. Remove the ignition key. Remove the ignition wire from the spark plugs.
2. Remove the bolts, lock washer, flat washers, and blades from the spindle shafts.

Replace

1. Put the blades, flat washers, lock washers, and the bolts back on the spindle shafts.
2. Tighten the bolts to a torque of 115-120 lbf-ft (156-162.6 N•m).
3. Replace the ignition wire on the spark plugs.

Sharpen the Mower Blades



CAUTION: DO NOT sharpen mower blades while on unit. An unbalanced mower blade will cause excessive vibration and eventual damage to unit. Check mower blade balance before reinstalling blades.

NEVER weld or straighten bent blades.

1. Remove mower blade from unit.

Discard mower blade if:

- More than 1/2 in. (1.27 cm) of metal is removed.
 - Air lifts become eroded.
 - Blade is bent or broken.
2. Sharpen mower blade by removing an equal amount of material from each end of mower blade. DO NOT change angle of cutting edge or round the corner of the mower blade.
 3. Check mower blade balance.

Slide mower blade on an unthreaded bolt. A balanced blade should remain in a horizontal position. If either end of mower blade moves downward, sharpen the heavy end until blade is balanced.
 4. Install mower blade(s) on unit.
 5. Tighten the bolts to a torque of 115-120 lbf-ft (156-162.6 N•m).

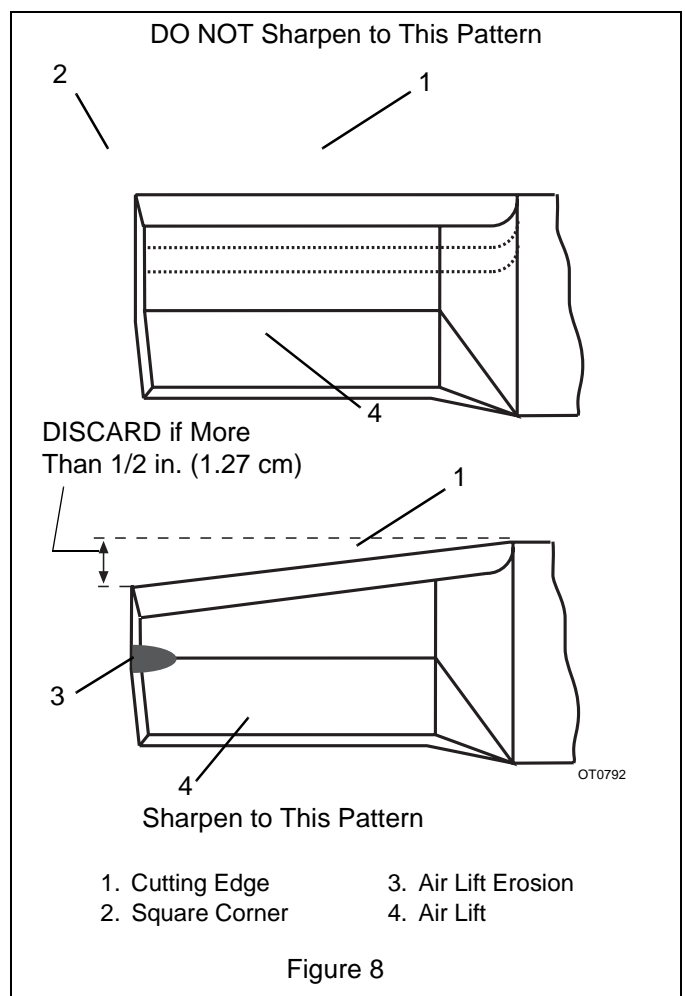

BATTERY



WARNING: AVOID INJURY. Read and understand entire *Safety* section before proceeding.



WARNING: Battery posts, terminals and related accessories contain lead and lead compounds, chemicals known to the State of California to cause cancer and reproductive harm. Wash hands after handling.

Unit comes equipped with a maintenance-free battery that requires no regular maintenance except cleaning the terminals.

Remove Battery

1. Shut OFF engine. Engage parking brake. Remove the ignition key.
2. Place seat in the service position (See *Service Positions* on page 17 in *Maintenance*).
3. Disconnect cables from battery (negative, then positive) (Figure 9).
4. Remove hold down and remove battery.

Replace Battery

1. Replace battery and secure with battery hold down.
2. Reconnect cables to battery (positive, then negative). Position boot over positive terminal.
3. Return seat to operating position.

Clean Battery

Keep battery and its terminals clean. Inspect every 100 operating hours or monthly for best performance.

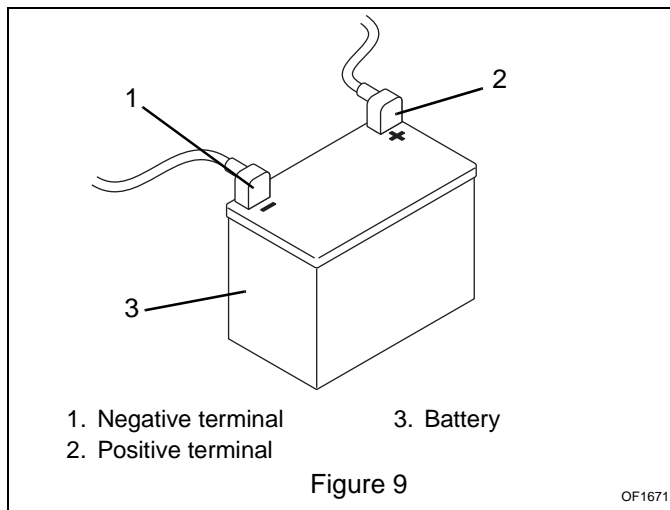

1. Remove battery from unit. See *Remove Battery* on page 19.
2. Clean terminals and battery cable ends with wire brush.

3. Coat terminals with dielectric grease or petroleum jelly.
4. Replace battery. See *Replace Battery* on page 19.

Charging the Battery

Battery Electrolyte First Aid

Follow First Aid directions for contact with battery fluid.

- External Contact: Flush with water.
- Eyes: Flush with water for at least 15 minutes and get medical attention immediately!
- Internal Contact: Drink large quantities of water. Follow with Milk of Magnesia, beaten egg or vegetable oil. Get medical attention immediately!

In case of internal contact, DO NOT induce vomiting!

IMPORTANT: DO NOT fast charge. Charging at a higher rate will damage or destroy battery. ONLY use an automatic charger designed for use with your battery.

ALWAYS follow information provided on battery by battery manufacturer. Contact battery manufacturer for extensive instructions to charge battery.

1. Remove battery from unit. See *Remove Battery* on page 19.
2. Place battery on bench or other well-ventilated place.
3. Connect positive (+) lead of charger to positive (+) terminal, and negative (-) lead to negative (-) terminal.
4. Charge battery according to charger and battery manufacturers' instructions.
5. Replace battery. See *Replace Battery* on page 19.

Jump Starting Battery

IMPORTANT: DO NOT jump start battery on model 992069. Failure to comply will void the engine warranty and can damage the engine.

The unit used for jump starting should have a 12 volt battery with at least 500 cold cranking amperes, and a negatively grounded system.

NOTE: Ensure battery is not frozen. If the fluid is frozen, remove battery from unit and allow it to thaw before charging.

1. Connect the positive (+) jumper cable to the positive terminal of the discharged battery (Figure 9).
2. Connect the other end of the same jumper cable to the positive (+) terminal of the booster battery.
3. Connect one end of the second jumper cable to the negative (-) terminal of the booster battery.
4. Make the final jumper cable connection to the engine block or the furthest ground point away from the discharged battery.



WARNING: Make sure cables are clear of any moving engine parts before starting engine.

5. Start engine (refer to Operation Section). If engine will not start after several tries, unit or battery may need service.
6. After engine starts, leave cables connected for one to two minutes.
7. Disconnect cables in reverse order.
8. Operate unit as normal to charge battery.

LUBRICATE UNIT

IMPORTANT: Wipe each fitting clean before and after lubrication.

Steering system and Speed Selector components should be lubricated every 50 hours of operation or every 3 months whichever comes first (Figure 10).

Lube fitting locations are:

- front axle pivot (2)

Apply Stens Mix Hi-Temp Grease or equivalent to the lube fittings. Order P/N: 00036700 - ten pack of 14 oz. cartridges.

When using Stens Mix Grease for the first time, all components should be thoroughly cleaned prior to lubricating.

Apply oil at all pivot points and pin connections.

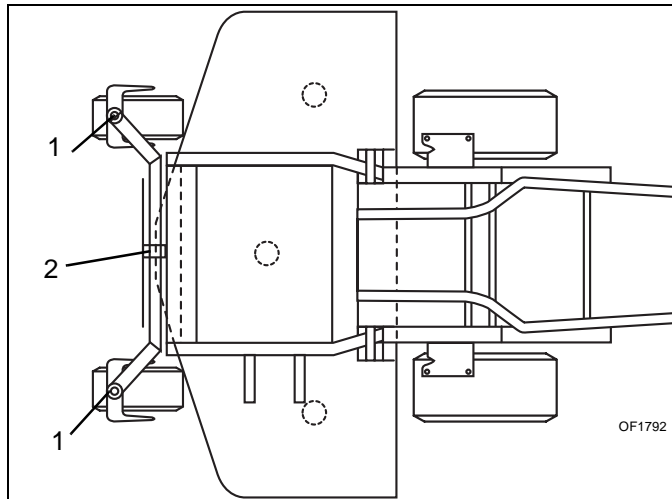

REF	LUBRICATION	QTY	DESCRIPTION-LOCATION	INTERVAL
1	REPACK	2	CASTER PIVOT	400 Hrs
2	GREASE	1	AXLE PIVOT	50 Hrs
	OIL		ALL PIVOT POINTS, PIN CONNECTIONS	50 Hrs

Figure 10

STEERING CONTROL NEUTRAL ADJUSTMENT

If the steering levers do not line up (match) or the unit has excessive creeping when the steering levers are in neutral, adjust as follows.

Adjusting the Steering Levers to Line Up (Match) (Figure 11)

1. Shut OFF engine. Engage parking brake. Remove the ignition key.
2. Place seat in the service position (See *Service Positions* on page 17 in *Maintenance*).
3. Loosen damper locknut on the same side as the steering lever to be adjusted.
4. Loosen brake interlock on the same side as steering lever to be adjusted.
5. Loosen tie rod jam nut and turn tie rod until steering levers are aligned.
6. Tighten jam nut on tie rod, tighten brake interlock and tighten damper locknut.

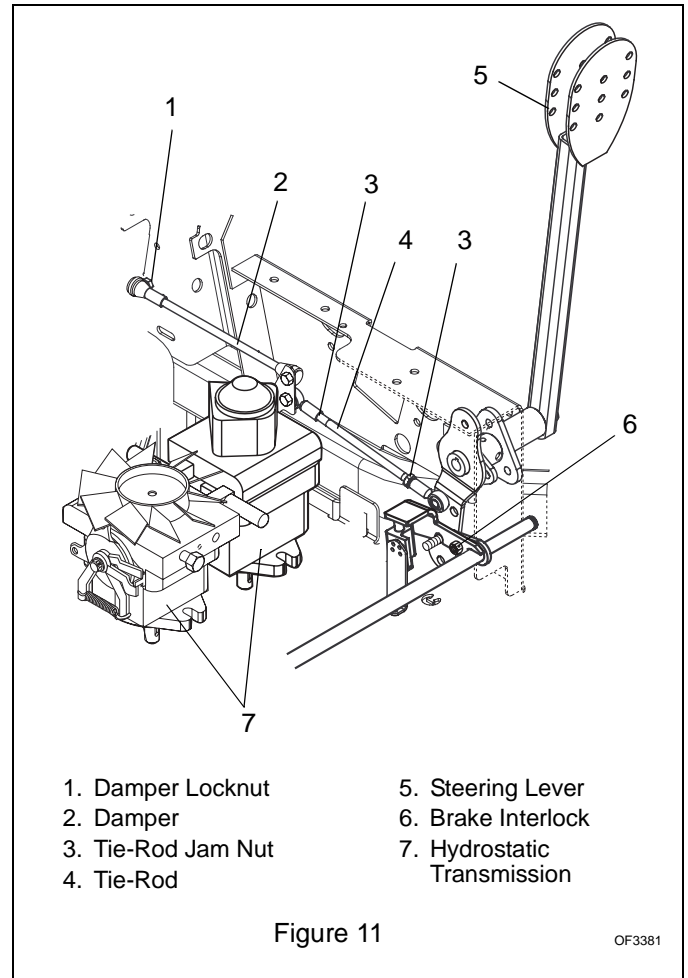

Eliminating Excessive Creeping of the Unit (Figure 11)

WARNING: This adjustment requires operating the engine. Use extreme care to avoid contact with moving parts and hot surfaces. Be sure rear of unit is well supported and secure before starting engine.

1. If hydraulic system is cold, run unit for a minimum of five minutes, then shut OFF engine.
2. With the unit up to and facing a wall, jack the unit up so that both drive wheels are off the ground.
3. Start the engine and release the parking brake.
4. Move the steering levers from Forward to Reverse several times to make sure controls are free. Then return steering levers to neutral position.
5. Check wheel(s) for movement.
6. Shut OFF engine.

NOTE: The right and left steering levers are adjusted the same way. To access the tie-rod, place seat in service position.

7. Adjust tie-rod(s):

If the wheel is moving in a forward direction:

- a. Loosen the jam nut on each end of the tie-rod.
- b. Turn tie-rod counterclockwise (lengthening the distance between the steering lever and hydrostatic transmission) several times.

If the wheel is moving in a reverse direction:

- a. Loosen the jam nut on each end of the tie-rod.
- b. Turn tie-rod clockwise (decreasing the distance between the steering lever and hydrostatic transmission) several times.

8. Return seat to operating position.
9. Start engine.
10. Move steering levers from Forward to Reverse several times. Then return steering levers to neutral position.
11. Shut OFF engine.
12. If wheel is not moving, tighten jam nuts on tie-rod. The adjustment is complete.
13. If wheel is still moving, repeat steps 7 through 12.

ADJUSTING THE UNIT TO TRACK STRAIGHT

WARNING: Prior to adjusting the tracking of the unit, shut OFF engine, engage parking brake, and remove the ignition key.

Check and adjust tire pressure. Increase pressure on side unit tracks to. DO NOT exceed maximum recommended tire pressure. See *Specifications* on page 27 for correct tire pressure.

If tire pressure adjustment does not solve tracking problem, adjust the limiter bolts on the stop bracket (Figure 12). Front bolts adjust forward and rear bolts adjust reverse. Lengthen the limiter bolt (move closer to lever) on side which is too fast.

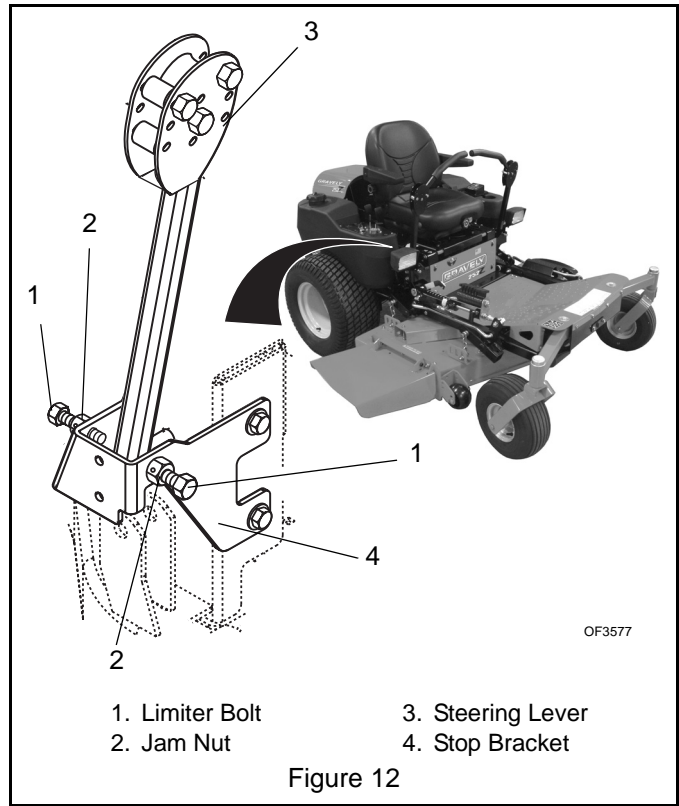

Figure 12

ADJUSTING THE HEIGHT OF THE STEERING LEVER HANDLES

The handles have three height positions (Figure 13).

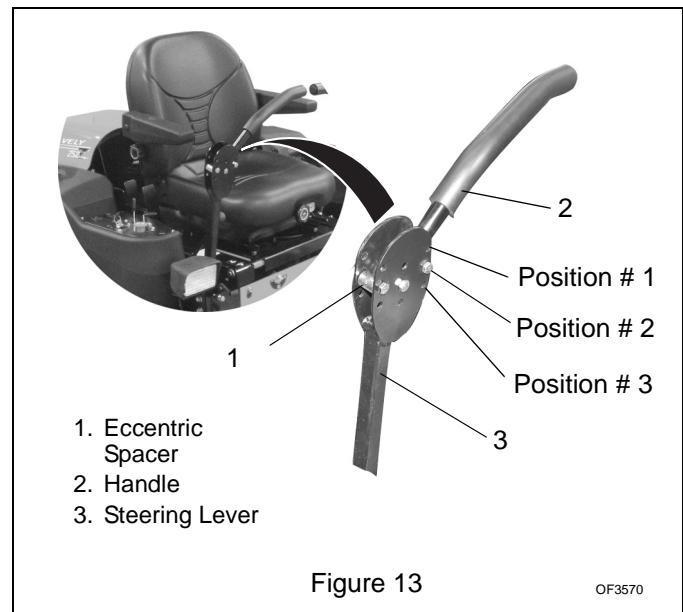

Figure 13

1. Shut OFF engine. Engage parking brake. Remove the ignition key.

- Remove the spacer, handle, and eccentric spacers from the steering lever.

NOTE: Position the right and left handles at the same height position.

- Install the eccentric spacers, spacers and handle in the appropriate height position. Do not tighten the nuts holding the eccentric spacers.
- Turn the eccentric spacer until the right and left handles are the same height. Tighten nut.

ADJUSTING THE PARKING BRAKE

The parking brake might need adjustment over time and after new brake pads have been installed.

NOTE: After installing new brake pads in the calipers, they must be burnished by driving for a short distance (about 100 feet) with the brake on. To do this, bring the parking brake lever part-way up while driving in a straight line. This quickly breaks-in the pads for maximum effectiveness.

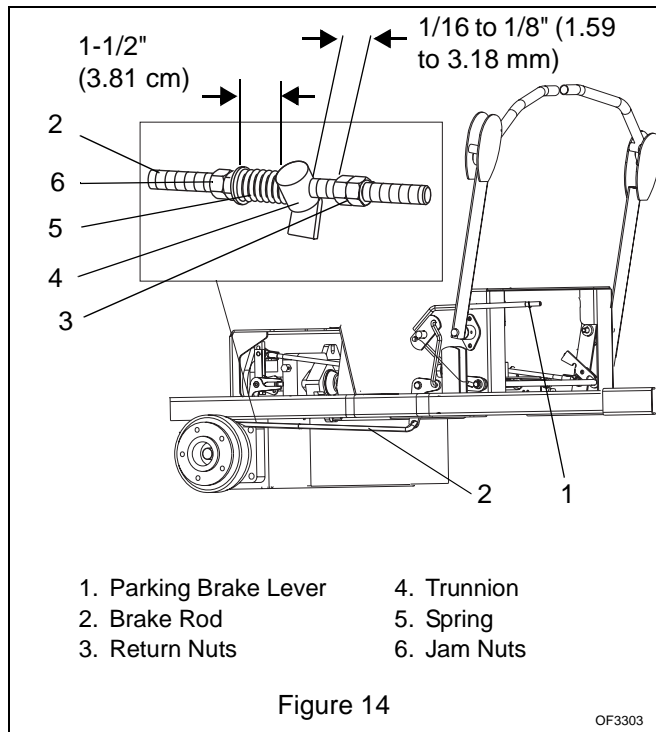

Check Adjustment

NOTE: Be sure to check the parking brake on both sides of the unit (Figure 14).

With the parking brake engaged, the spring length should measure 1 1/2" between the jam nuts and the trunnion and the clearance between the return nuts and trunnion should measure 1/16 to 1/8" (1.59 to 3.18 mm). If either of these measurements is off, adjust the parking brake appropriately.

Adjust the Parking Brake

- Engage the parking brake.
- Turn the jam nuts clockwise to compress the spring or counterclockwise to extend the spring until there

is 1-1/2" (3.81 cm) clearance between the jam nuts and trunnion.

- Tighten jam nuts together.
- Turn the return nuts clockwise to decrease the distance or counterclockwise to increase the distance until there is 1/16 to 1/8" (1.59 to 3.18 mm) between the return nuts and trunnion.
- Tighten return nuts together.

BELTS

WARNING: MOVING PARTS can cut or amputate body parts. ALWAYS wait for moving parts to stop before performing maintenance or service.

CAUTION: DAMAGED OR WORN BELTS may result in injury and/or damage to unit. Check belts for excessive wear or cracks often.

Belt Access

- Properly stop and park unit (refer to Operation Section).
- Lower the mower.
- Place seat in most rearward position.
- Remove belt covers.
- Place foot board in open position (Figure 15).
- Secure raised footboard with latch.

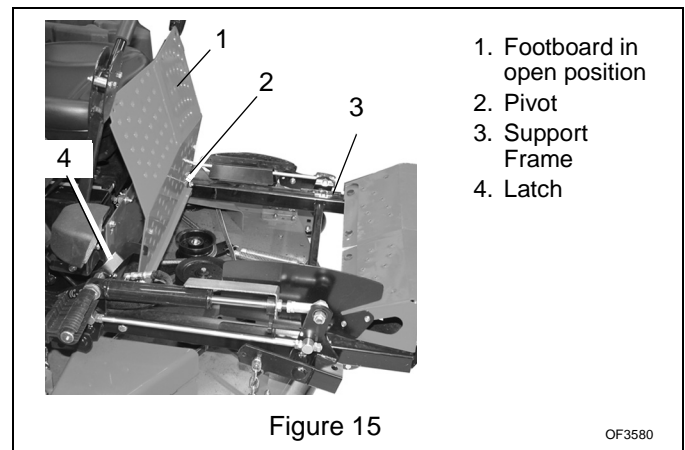

Replacing Mower Belts

NOTE: Long mower belt must be removed to remove short mower belt.

CAUTION: Use care when releasing idler spring tension. Keep body parts well away from idlers when performing this operation.

- Slowly release the tension on the long mower belt idler until all the tension is removed from the springs.

2. Remove long mower belt from left blade spindle and remove from deck.
3. Slowly release the tension on the short belt idler until all the tension is removed from the springs.
4. Remove short mower belt from right blade spindle and from deck. Idler pivot bolt must be loosened slightly to gain clearance to remove belt from under idler pulley (Figure 16).
5. Arrange new mower belt(s) on deck (short belt first). Retighten short mower belt idler pivot bolt. Install belts on sheaves. Put belts onto center sheave last.
6. Replace belt covers and return foot board to closed position.

4. Slowly release the tension on the hydro pump belt idler until all the tension is removed from the springs.
5. Remove old hydro pump belt from right hand hydrostat sheave first (Figure 17).
6. Install new hydro pump belt by positioning belt on sheaves. Put belt onto right hand hydrostat sheave last.
7. Replace clutch anchor.
8. Replace long mower belt on mower clutch sheave. See *Replacing Mower Belts* on page 22.

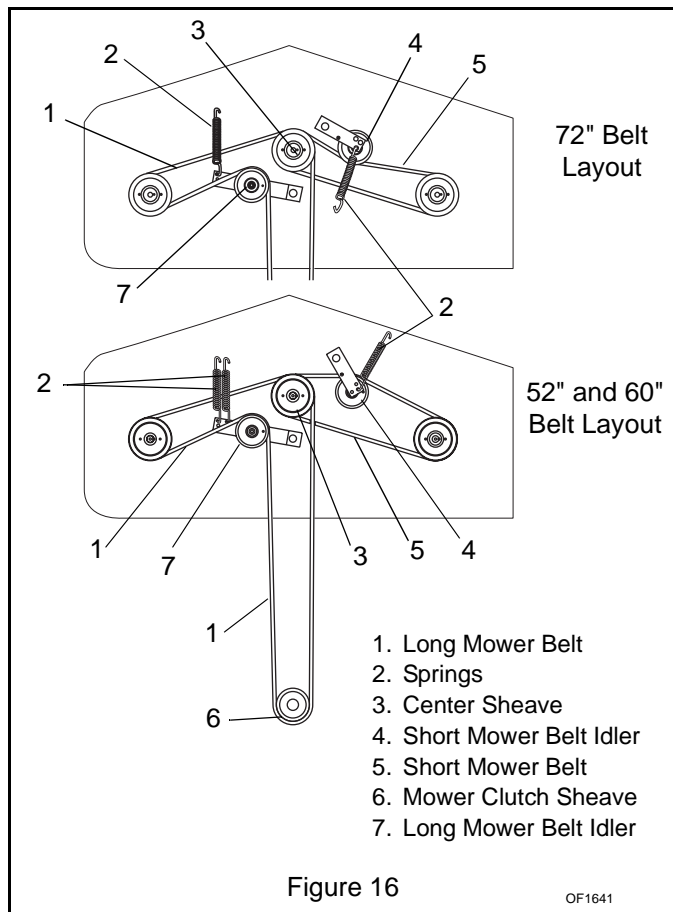

Replacing the Hydro Pump Belt

1. Properly stop and park unit (refer to Operation Section).
2. Remove the long mower belt from the mower clutch sheave. See *Replacing Mower Belts* on page 22.



CAUTION: Use care when releasing idler spring tension. Keep body parts well away from idlers when performing this operation.

3. Remove clutch anchor.

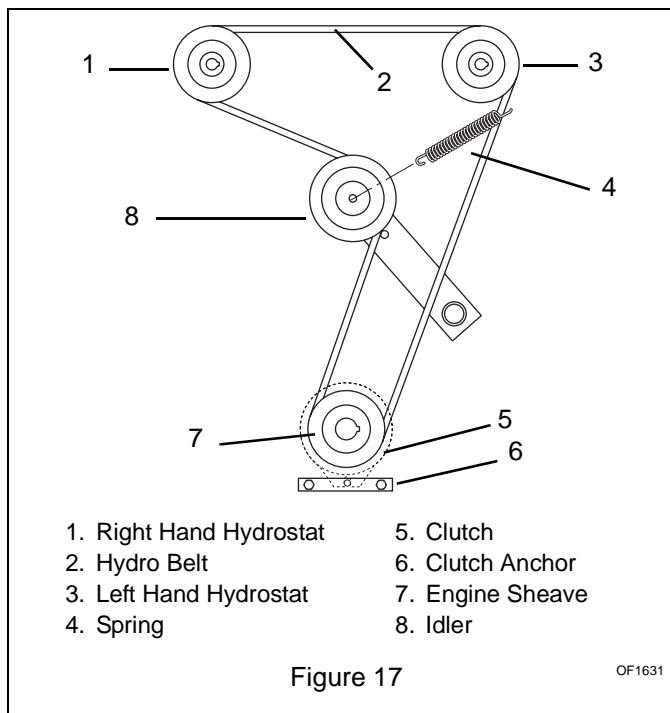

MOWER DECKS

Adjusting Anti-Scalp Rollers

The anti-scalp rollers are set at the factory for typical mowing height, but can be adjusted for high or low cutting conditions (Figure 18).

Rollers are intended to prevent lawn scalping, not to control cutting height.

For a very high cutting height, set the rollers in their lowest position on the bracket.

For a very low cutting height, set the rollers in their highest position on the bracket.

All rollers should be set at the same height.

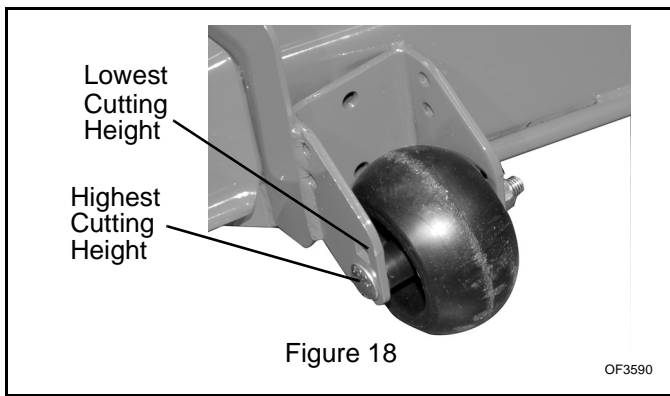

Figure 18

Removing the Mower Deck

1. Remove PTO (long) mower belt. See *Replacing Mower Belts* on page 22.
2. Remove link chains from mower lift arms. Note hole location on mower lift arms for replacement.
3. Remove mower mounting arms from frame.
4. Slide mower deck out from under unit.

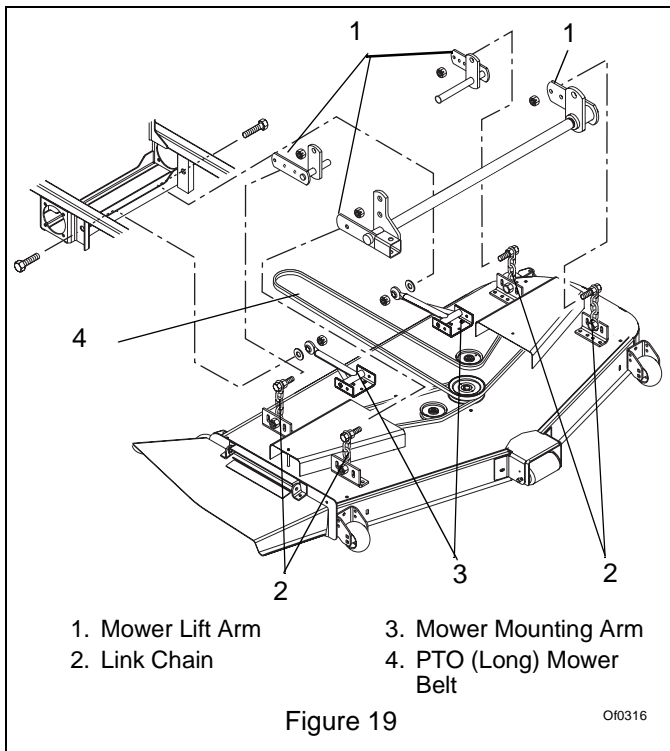

Figure 19

Installing the Mower Deck

1. Slide mower deck under unit.
2. Install mower mounting arms on frame.
3. Install link chains on the mower lift arms in the same holes they were removed from.
4. Install PTO (long) mower belt. See *Replacing Mower Belts* on page 22.
5. Level mower deck.

Leveling the Mower Deck

These adjustments should be made on a level surface with the tires inflated to the correct air pressure.

Level the mower with the slots where 4 chains fasten to the mower mounting brackets (Figure 20).

1. Shut off engine. Engage parking brake. Remove the ignition key.
2. Raise mower deck to its highest position and place 4.75 in. (12.1 cm) tall blocks at each rear corner and 4.625 in. (11.7 cm) tall blocks at each front corner.
3. Lower deck onto the blocks.
4. Loosen the locknuts on the side where the chains are slack and slide the bolt down the slot until the chains are tight.
5. Tighten the locknuts.
6. Lift mower and remove blocks.
7. Measure height of deck at each side. Measurements must be within 3/16 in. (4.76 mm) of each other.
8. If measurements are out of range, fix by adjusting chains on low side of deck.
9. Once deck is level side to side, measure height of deck at middle of front and on both sides of rear. Front of deck should be 1/8 in. \pm 1/8 in. (3.18 \pm 3.18 mm) lower than rear.

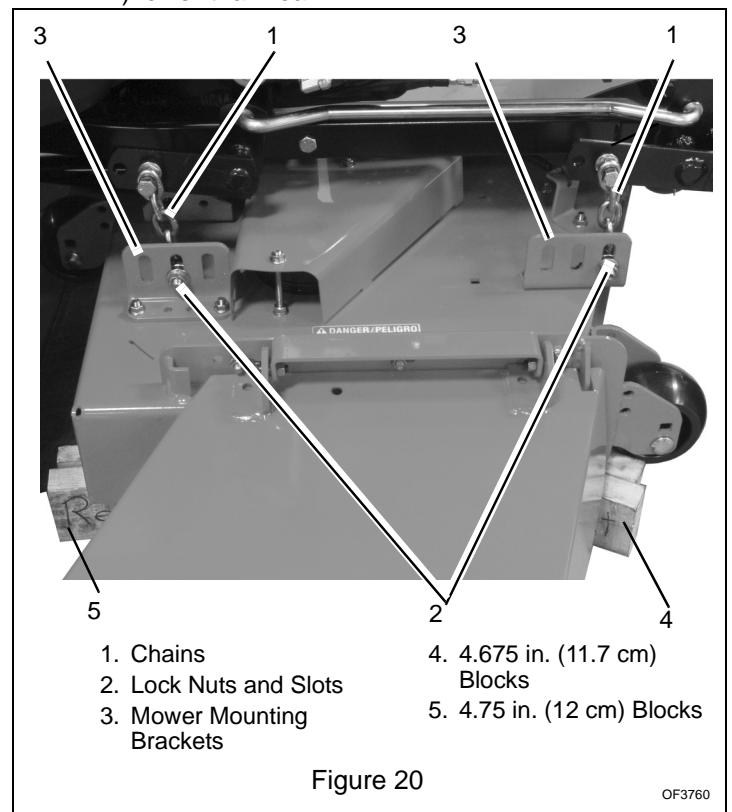

Figure 20

STORAGE



WARNING: AVOID INJURY. Read and understand entire *Safety* section before proceeding.

SHORT TERM

NEVER spray unit with high pressure water or store unit outdoors.

Inspect unit for visible signs of wear, breakage or damage.

Keep all nuts, bolts and screws properly tightened and know unit is in safe working condition.

Store unit in a cool, dry protected area.

LONG TERM

Clean unit thoroughly with mild soap and low pressure water and lubricate (See *Lubricate Unit* on page 20 in *Maintenance*). Touch up all scratched painted surfaces.

Remove weight from wheels by putting blocks under frame or axle.

When storing unit for extended periods of time, remove all fuel from tank and carburetor (run dry). Refer to Engine Manual.

Clean and charge the battery. Charge battery every three to four weeks when storing unit.

To Take the Unit Out of Storage

1. Refer to the engine service manual to prepare the engine for service.
2. Put fresh, clean fuel in the fuel tank.
3. Begin the maintenance schedule.
4. Charge and install the battery.

TROUBLESHOOTING

PROBLEM	PROBABLE CAUSE	CORRECTION
Engine does not crank.	<ol style="list-style-type: none"> 1. PTO engaged. 2. Parking brake disengaged. 3. Loose or corroded battery cables. 4. Discharged battery. 5. Faulty starter. 	<ol style="list-style-type: none"> 1. Disengage PTO. 2. Engage parking brake. 3. Clean and tighten battery cables (see <i>Battery</i> on page 19). 4. Charge battery (see <i>Battery</i> on page 19). 5. See your Gravely Dealer.
Engine cranks but does not start.	<ol style="list-style-type: none"> 1. Fuel tank empty. 2. Faulty spark plug. 3. Air cleaner is plugged or dirty. 4. Fuel filter is dirty. 5. Faulty engine. 	<ol style="list-style-type: none"> 1. Fill fuel tank (see <i>Filling Fuel Tank</i> on page 13). 2. Replace spark plug. Refer to Engine Manual. 3. Clean or replace air cleaner. Refer to Engine Manual. 4. Clean or replace fuel filter. Refer to Engine Manual. 5. Refer to Engine Manual or see your Gravely Dealer.
Battery light does not light up when starting engine.	<ol style="list-style-type: none"> 1. Discharged battery. 	<ol style="list-style-type: none"> 1. Charge battery (see <i>Battery</i> on page 19).
Oil pressure light is on.	<ol style="list-style-type: none"> 1. Oil pressure is low. 	<ol style="list-style-type: none"> 1. Refer to Engine Manual.
Engine continues to run when ignition key is in the off position.	<ol style="list-style-type: none"> 1. Ignition ground wire disconnected. 2. Ignition switch failure. 	<ol style="list-style-type: none"> 1. Connect ground wire to clean metal surface. 2. Replace ignition switch (see your Gravely Dealer).

TROUBLESHOOTING

PROBLEM	PROBABLE CAUSE	CORRECTION
PTO or mower blades do not engage or shuts off.	<ol style="list-style-type: none"> Operator presence switch not depressed. Eye-Q™ alarm setting is turned on. The Eye-Q™ circuitry senses an overload to the PTO clutch and is shutting off the PTO switch. Faulty PTO switch. 	<ol style="list-style-type: none"> Depress operator presence switch by sitting on seat. Turn off the alarm that deactivates the PTO on a regular schedule. See Eye-Q Owner's Manual. Check the mower deck for clogging or debris. Check the electrical system to the clutch for damage or wear. See your Gravely Dealer.
Unit does not drive.	<ol style="list-style-type: none"> Parking brake engaged. Transmission bypass levers open. Hydraulic oil level low. Faulty hydraulic drive system. 	<ol style="list-style-type: none"> Disengage parking brake. Close transmission bypass levers (see <i>Moving the Unit with the Engine Off</i> on page 14). Add hydraulic oil (see <i>Hydraulic Fluid</i> on page 17). See your Gravely dealer.

ACCESSORIES

Part No.	Description
78803500	52" Mulching Kit
78803900	52" Bahia/Tall Grass Baffle Kit
79200300	60" Mulching Kit
79200400	Discharge Cover Kit - 60" Decks
79200900	72" Mulching Kit
79201000	Discharge Cover Kit - 72" Decks
79201600	60" Bahia/Tall Grass Baffle Kit
79201700	Counterweight Kit
79202000	72" Bahia/Tall Grass Baffle Kit
79202100	Liftmaster Kit
79202300	Hitch Kit
79202400	Antiscalp Wheel Kit
79202600	Lawn Striper Kit, 60" and 72"
79202800	Discharge Cover Kit - 52" Decks
79203100	Lawn Striper Kit, 52"
89200100	Rollover Protection System (ROPS)
89200200	60" Bagger (Peco) (requires bumper p/n 09249953)
89200500	60" Bagger

SERVICE PARTS

Part No.	Qty	Description
01554800	1	Battery
21539600	1	Air Filter Outer Element - Kawasaki
21539700	1	Air Filter Inner Element - Kawasaki
21537000	1	Outer Primary Element - Kohler
21536900	1	Inner Safety Element - Kohler
21536300	1	Element Precleaner - Kohler 25 HP
21535800	1	Engine Oil Filter - Kawasaki
21397200	1	Engine Oil Filter - Kohler
09246900	1	Hydraulic Oil Filter
21536100	2	Spark Plug - Kawasaki
21525900	2	Spark Plug - Kohler
07240700	1	PTO (Engine to Deck) Belt (52")
07241300	1	PTO (Engine to Deck) Belt (60")
07242300	1	PTO (Engine to Deck) Belt (72")
07222300	1	Mower Drive Belt (52")
07235000	1	Mower Drive Belt (60")
07237700	1	Mower Drive Belt (72")
07242000	1	Traction (Hydro Pump) Belt - Poly V
04916400	1	Blade (52")
04917900	1	Mulch Blade (52")
09081200	1	Blade (60")
08866900	1	Mulch Blade (60")
09290500	1	Blade (72")
09290600	1	Mulch Blade (72")

SPECIFICATIONS

Model Number	992066	992067	992068	992069	992070	992071	992072
Model	252Z	260Z	260Z	260Z	272Z	252Z	272Z
Length – cm (in)	203 (80)						
Height – cm (in)	127 (50)						
Width – cm (in)	165 (65)	185 (73)			216 (85)	165 (65)	216 (85)
Weight Actual – kg (lbs)	476.2 (1050)	510.2 (1125)			532.9 (1175)	476.2 (1050)	532.9 (1175)
Battery	12 volt						
Brakes	Hydro/Dynamic Drum– Parking						
Turning Radius	0						
Tire Size Front Rear	15 x 6 - 6 24 x 12 - 12						
Engine – manufacturer	Kawasaki	Kawasaki	Kohler	Kohler EFI	Kawasaki	Kohler	
Model Number	FH721V		CV740S	CV74SS	FH721V	CV740S	
Cycle	4						
Engine Power – HP (kW) @ Governed RPM	25 (18.6)		27 (20.1)	28 (20.9)	25 (18.6)	27 (20.1)	
Governed RPM	3600						
Idle RPM	1800						
Starting System	Electric						
Fuel Tank Capacity	14 gals. US (53 liters)						
Fuel	See Engine Manual						
Air Cleaner	Heavy Duty Dual Element with Pre-Clean Screen						
Cooling Capacity	Air Cooled						
Engine oil type	See Engine Manual						
Spark Plug Gap	See Engine Manual						
Transmission	Hydrostatic Drive						
Speed – Forward Max. Reverse Max.	13 MPH (20.8 KM/H) 6 MPH (9.6 KM/H)						
Transmission Lube	Mobil 1 15W-50 Synthetic						
Drive Clutch	Hydrostatic						
Tire Pressure Front Rear	20-25 psi (138-172 kN/m ²) 12-15 psi (83-103 kN/m ²)						
Lift System	Hydraulic						
Power Take Off	Electric PTO Clutch/Brake						
Cutting Width – cm (in)	132 (52)	152 (60)			183 (72)	132 (52)	183 (72)
Cutting Height – cm (in)	2.5 - 12.7 (1 - 5)						
Cut Increments – cm (in)	Infinite between 2.5 -12.7 (1 - 5)						
Max. Towing Capacity – kg (lbs)	226.8 (500)						
Max. Tongue Weight – kg (lbs)	22.7 (50)						



Gravely Division of Ariens Company
655 West Ryan Street
P.O. Box 157
Brillion, WI 54110-0157
920-756-2141
Fax 920-756-2407
www.gravely.com

2-Year Limited Warranty

Gravely Division of Ariens Company (Gravely) hereby warrants to the original consumer purchaser that all Gravely Two-Wheel, Professional G, Pro, and ProMaster products will be free from defects in material and workmanship for a period of two (2) years from the date of purchase or 1000 hours, whichever comes first.

Protection Plan

Gravely will repair or replace any part found upon examination by Gravely to be defective. Such repair or replacement will be free of charge to the purchaser (labor and parts), except as noted below.

This warranty is subject to the following exceptions, conditions, and limitations:

Usage Requirement

The duration of this warranty shall be ninety days or 1000 hours, whichever comes first, if the product is rented or leased.

Purchaser's Responsibilities

- The purchaser must perform maintenance and minor adjustments per the operator's manual.
- The purchaser must notify Gravely or an authorized Gravely service representative of the need for warranty service.
- The purchaser must transport the product to and from the place of warranty repair.

Product Registration

- Returning the product registration card to Gravely will enable the company to contact the registrant with repair or replacement part information.

Service Parts and Accessories

- Service parts and accessories not purchased with the product covered by this warranty are warranted to be free of defects for a period of ninety (90) days following the date of purchase, and will be replaced free of charge (except for labor).

Service

- Warranty service must be done by an authorized Gravely dealer. To find an authorized Gravely service representative, contact Gravely at the website, number or address above.

Battery Warranty Prorated

- One to three months - Free replacement
- Four to twelve months - Prorated over 12 months

Exclusions (No Warranty)

- Normal maintenance, services, and normal replacement items, such as spark plugs, oil, oil filters, air filters, mufflers, belts, tires, shoes, runners, scraper blades, shear bolts, mower blades, mower vanes, headlights, light bulbs, knives, etc. are not covered by this warranty.
- Any equipment which has been altered, misused, misassembled, improperly adjusted, neglected, or damaged by accident is not covered by this warranty.
- Service completed by someone other than an authorized Gravely dealer is not covered by this warranty.
- Any attachment not approved by Gravely nor any parts that are not genuine Gravely service parts are not covered by this warranty.
- Engines and engine accessories are covered only by the warranty made by the engine manufacturer, and are not covered by this warranty.
- If the product is equipped with a Hydro-Gear transmission and/or Hydro-Gear drive components, the Hydro-Gear transmission and/or drive components are covered only by the warranty made by Hydro-Gear, and are not covered by this warranty.
- This warranty applies only to products purchased in the United States (including Puerto Rico) and Canada. In all other countries, contact place of purchase.

Gravely may from time to time change the design of its products. Nothing contained in this warranty shall be construed as obligating Gravely to incorporate such design changes into previously manufactured products, nor shall such changes be construed as an admission that previous designs were defective.

LIMITATION OF REMEDY AND DAMAGES

Gravely's liability under this express warranty, and under any implied warranty that may exist, is limited to repair or replacement of any defective part. In no event shall Gravely be liable for incidental, special, or consequential damages (including lost profits). This warranty gives you specific legal rights. You may also have other rights which vary from state to state. Some states do not allow the exclusion of incidental or consequential damages, or limitations on how long an implied warranty lasts, so the above limitations and exclusions may not apply to you.

DISCLAIMER OF FURTHER WARRANTY

Gravely makes no warranty other than what is expressly made in this warranty. If the law of your state provides that an implied warranty of merchantability, or an implied warranty of fitness for a particular purpose, applies to Gravely, any such implied warranty is limited to the duration of this express warranty.

Form: GLW2-122002



GRAVELY
A Division of Ariens Company
655 West Ryan Street
P.O. Box 157
Brillion, WI 54110-0157
920-756-2141
Fax 920-756-2407
www.gravelly.com