

# FURUNO

## OPERATOR'S MANUAL

SCANBEAM SOUNDER

MODEL FCV – 10

( Display Unit )



**FURUNO ELECTRIC CO., LTD.**  
NISHINOMIYA, JAPAN

©FURUNO ELECTRIC CO., LTD.

9-52, Ashihara-cho,  
Nishinomiya, Japan 662

Telephone: 0798-65-2111  
Telefax: 0798-65-4200

All rights reserved. Printed in Japan

-Your Local Agent/Dealer

FIRST EDITION : SEP 1990  
H : DEC. 8, 1998

(TATA)

PUB. No. OME-23230  
FCV-10 (FE-1280)





# SAFETY INSTRUCTIONS

"DANGER", "WARNING" and "CAUTION" notices appear throughout this manual. It is the responsibility of the operator and installer of the equipment to read, understand and follow these notices. If you have any questions regarding these safety instructions, please contact a FURUNO agent or dealer.



**DANGER**

This notice indicates a potentially hazardous situation which, if not avoided, will result in death or serious injury.



**WARNING**

This notice indicates a potentially hazardous situation which, if not avoided, could result in death or serious injury.



**CAUTION**

This notice indicates a potentially hazardous situation which, if not avoided, could result in minor or moderate injury, or property damage.



# SAFETY INFORMATION FOR THE OPERATOR

## **WARNING**



**Do not open the cover of the equipment.**

This equipment uses high voltage electricity which can shock, burn, or cause death. Only qualified personnel should work inside the equipment.

**Do not disassemble or modify the equipment.**

Fire, electrical shock or serious injury can result.

**Immediately turn off the power at the ship's mains switchboard if water or foreign object falls into the equipment or the equipment is emitting smoke or fire.**

Continued use of the equipment can cause fire, electrical shock or serious injury.

## **CAUTION**

**Do not place liquid-filled containers on the top of the equipment.**

Fire or electrical shock can result if a liquid spills into the equipment.

**Do not place heater near the equipment.**

Heat can melt the power cord, which can result in fire or electrical shock.

**Do not operate the unit with wet hands.**

Electrical shock can result.

**Use the correct fuse.**

Use of the wrong fuse can cause fire or equipment damage.

*(Continued on next page)*

# NOTICE

**Do not use the equipment for other than its intended purpose.**

Use of the equipment as a chair or a shelf, for example, can cause equipment damage.

**Immediately turn off the power whenever you feel the equipment is abnormal.**

Continued use can cause equipment damage.

**The useable temperature range is 0°C to 50°C.**

Use out of the range can cause equipment damage.

**Keep magnets and magnetic fields (speaker, transformer, etc.) away from the equipment.**

Magnets and magnetic fields can cause equipment malfunction.

**Do not place objects near the equipment.**

Objects near the equipment can cause overheating.

**Handle the equipment carefully.**

Rough handling can cause corrosion.

**Do not use chemical cleaners to clean the equipment.**

Chemical cleaners can remove paint and markings.



# SAFETY INFORMATION FOR THE INSTALLER

## **WARNING**



Only qualified personnel should work inside the equipment.

This equipment uses high voltage electricity which can shock, burn, or cause death.

**Turn off the power at the ship's mains switchboard before beginning the installation. Post a warning sign near the switchboard to ensure that the power will not be applied while the equipment is being installed.**

Serious injury or death can result if the power is not turned off, or is applied while the equipment is being installed.

## **CAUTION**



Ground the equipment to prevent electrical shock and mutual interference.

Ungrounded equipment can give off or receive electromagnetic interference or cause electrical shock.

**Confirm that the power supply voltage is compatible with the voltage rating of the equipment.**

Connection to the wrong power supply can cause fire or equipment damage. The voltage rating appears on the label at the rear of the equipment.

## **NOTICE**

**The mounting location must satisfy the following conditions:**

- Away from rain and water splash
- Out of direct sunlight
- Away from air conditioner vents
- Away from magnets and magnetic fields
- Moderate and stable in temperature and humidity

# HANDLING PRECAUTIONS

- Moderate screen brightness to extend the life of the CRT.
- Do not remove the display cover. High voltage exists inside the unit.
- Do not use too high a setting of the CLUTTER control, or small and weak fish echoes may be missed.
- Observing the following points will help to keep your FCV-10 in top condition for many years.

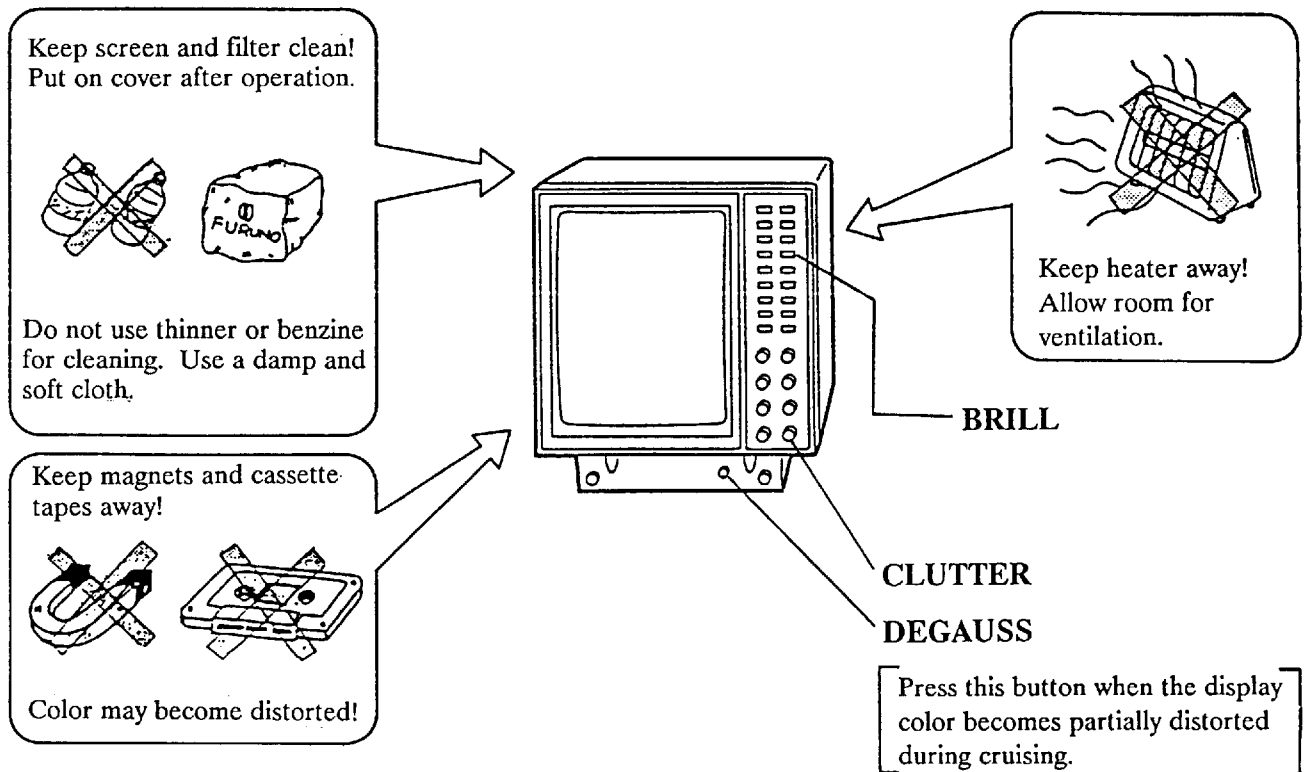

# Table of Contents

---

## HANDLING PRECAUTIONS

<b>1. A WORD TO FURUNO FCV-10 OWNERS:</b> .....	<b>1</b>
Features.....	1
<b>2. SYSTEM CONFIGURATION</b> .....	<b>3</b>
<b>3. OPERATING CONTROLS AND KEYS</b> .....	<b>4</b>
Before Turning ON the Power .....	4
<b>4. DESCRIPTION OF CONTROL PANEL</b> .....	<b>5</b>
<b>5. DISPLAY MODES</b> .....	<b>6</b>
Variety of Displays.....	6
Vertical display .....	6
Port display.....	6
STBD (Starboard) display.....	6
Auto scan display.....	6
Example of Display Selection .....	6
<b>6. OPERATION</b> .....	<b>7</b>
Turning Power On/Off .....	7
Adjusting Brilliance.....	7
Selecting Combination of Display Colors .....	7
Selecting Display RANGE .....	7
Shifting Range .....	8
Display Advance Speed Selection.....	8
Adjusting GAIN .....	9
Adjusting TVG .....	10
Removing Clutter .....	10
Selecting Display Mode .....	11
Selecting Sub-Mode Display .....	12
Selecting Transmit Direction.....	12
Selecting Transmit Angle .....	13
Selecting Display Range for Pelagic Expansion and Bottom-locked Expansion.....	13
Selecting Net Recorder Display Range .....	14
Using the Vertical and Horizontal VRMs .....	14
Storing/Recalling Picture .....	15
A-Scope Presentation .....	16
Quick Display Selection Table.....	17
<b>7. INTERPRETING THE DISPLAY</b> .....	<b>18</b>



Example of Display (3- Display Mode) .....	18
Scanning Area of Sounding Beams .....	19
One sounding beam .....	19
Two sounding beams.....	19
Three sounding beams .....	20
Auto scanned beam.....	20
Using Three Direction Combination Display.....	21
False Echo by Sidelobe of Sounding Beam .....	21
<b>8. CHANGE OF OPERATING MODE BY MENU .....</b>	<b>22</b>
Basic Operation.....	22
Initial Menu .....	23
Transmitter Menu .....	24
Receiver Menu.....	25
Display Menu.....	26
Depth Range Menu .....	27
Fine Tuning Hue .....	27
<b>9. IF SOMETHING SHOULD GO WRONG WITH YOUR UNIT.....</b>	<b>29</b>
Operation Check .....	29
No Echo Presentation, But Scale Shows.....	29
No Zero Line.....	29
Low Sensitivity.....	29
No Water Depth Readout/Bottom Lock Inoperative.....	30
Display Color Distorted.....	30
System Diagnosis (Self-check).....	30
Memory ICs (Check 1) .....	30
Checking Controls and Keys on the Front Panel (Check 2) .....	31
Checking With the LED Displays .....	31
Checking With Demo Display .....	33
<b>10. SPECIFICATIONS .....</b>	<b>35</b>
<b>11. INSTALLATION .....</b>	<b>40</b>
Recommended Installtion of Transducer CV-102.....	40
Assembling thr Transfucer Cable .....	42
Modifying Unit for Connection with FE-1282 .....	43
Installing Clinometer Unit.....	44
Calibration of Clinometer .....	44
<b>INDEX .....</b>	<b>45</b>
<b>INTERCONNECTION DIAGRAMS/OUTLINE DRAWINGS .....</b>	<b>D-1</b>
<b>SCHEMATIC DIAGRAMS .....</b>	<b>S-1</b>

---

## 1. A WORD TO FURUNO FCV-10 OWNERS:

---

Congratulation on your choice of the **FURUNO FCV-10** Scanbeam Sounder! For over 40 years Furuno Electric Company has enjoyed an enviable reputation for quality and reliability throughout the world. This dedication to excellence is furthered by our extensive global network of agents and dealers.

The **FURUNO FCV-10** is designed and constructed to give the user many years of trouble-free operation. However, to obtain optimum performance from this unit, you should carefully read and follow the recommended procedures for installation, operation and maintenance. No machine can perform to the utmost of its ability unless it is installed and maintained properly.

Thank you for considering and purchasing Furuno equipment.

---

### FEATURES

---

- 16-color presentation (including background) shows detailed information on fish density and the nature of the bottom, on a 14" diagonal medium resolution CRT. Selectable background color lessens eye-fatigue in both daytime and nighttime operations.
- In addition to a real-time color display, the **FE-1280** paper recorder is optionally available for extended recording of underwater searching for later reference.
- The high power and narrow beam transducer of 24 kHz, 10 kW, 10 degrees (port-starboard) x 9.5 degrees (fore-aft) has a maximum detection range up to 6000 m deep.
- The transducer transmits and receives three sounding beams towards ship's port and starboard as well as downward. Searching area is thus three times that of a single beam detection. In the automatic scanning mode, the transmitting beam is scanned between the selected transmit angles in port and starboard. This feature is useful for observing fish behavior and seabed nature.
- To stabilize a sounding beam against ship's rolling, a clinometer unit is provided standard. This ensures stable picture presentation of fishes and seabed echoes even under severe weather conditions.
- The split screens simultaneously display detected echoes from an external net recorder or echo sounders as well as own transceiver-detected echoes if these units are connected to the display unit.
- Display of ship's position and water temperature. (External navigation equipment and water temperature indicator required)

- The A-scope presentation provides detailed presentation of echoes every transmission of ultrasonic pulse by the transceiver unit. This feature is especially useful for trawling where detailed presentation of bottom fish is important.
- Bottom locked expansion and pelagic expansion displays give you highly detailed presentations of echoes.

## 2. SYSTEM CONFIGURATION

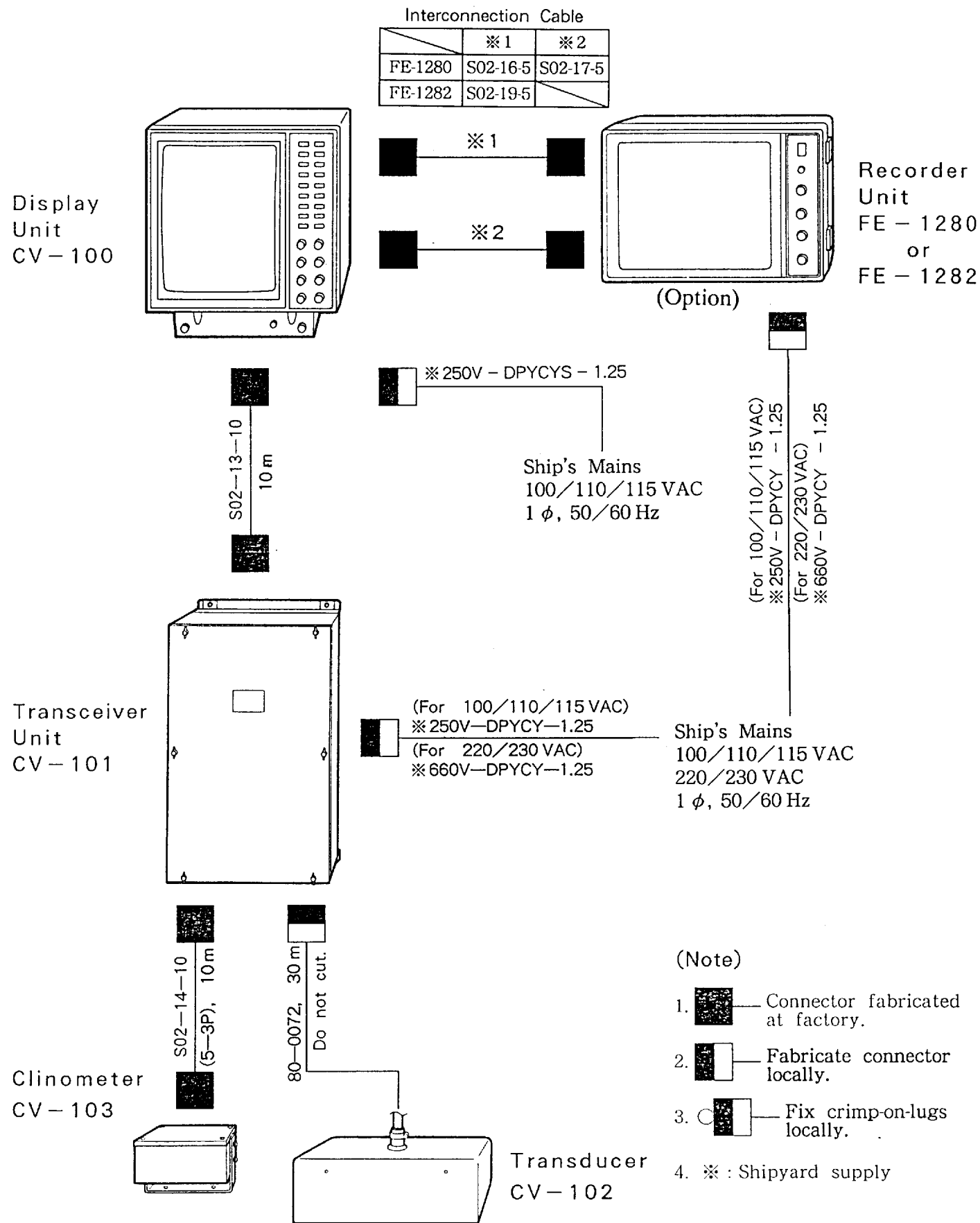

### 《 Interfaced to 》

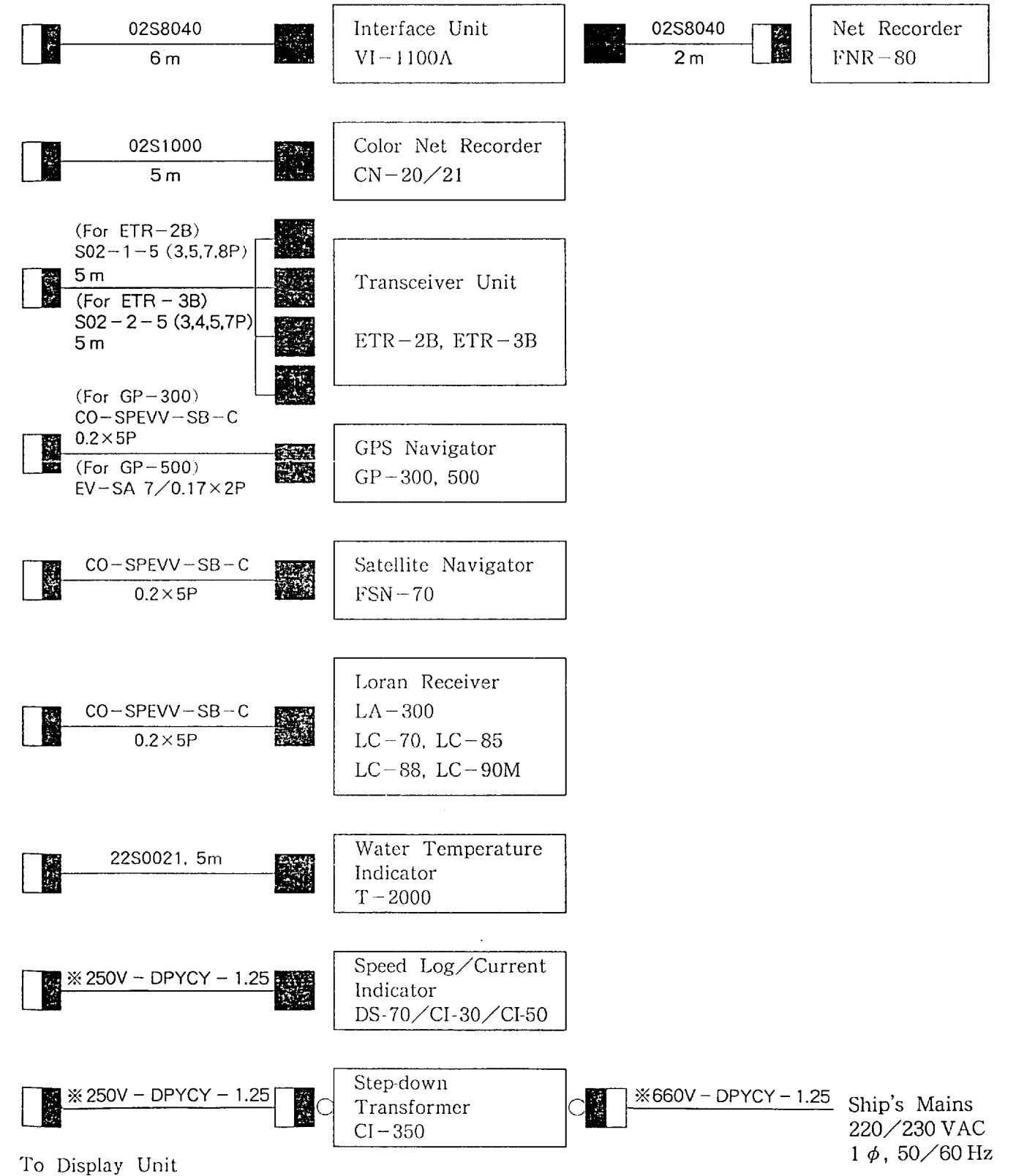

---

### 3. OPERATING CONTROLS AND KEYS

---

The FCV-10 Scanbeam Sounder has a color display unit and a paper recorder unit FE-1280 (option) as output devices. Each unit has individual operating controls and keys. This manual explains the color display unit. For the FE-1280 paper recorder, refer to the operator's manual for the FE-1280 Scanbeam Sounder recorder unit which is separately published.

Take a look at the display unit. The front part of the display unit is separated into two sections: controls and keys on the right-hand side and the CRT on the left-hand side. Operation is simple and straight forward. If you press a key or operate a control the associated reaction is seen on the screen almost immediately.

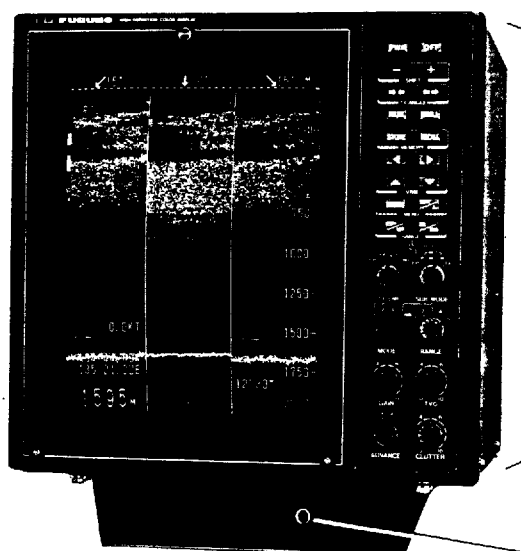

#### CONTROL PANEL

A brief description of the function of each key and control appears on the next page.

#### DEGAUSS Button

Press this button when the display color becomes partially distorted by unwanted access of magnetic field or change of terrestrial magnetism during sailing.

F Photo No.1922 PC

---

### BEFORE TURNING ON THE POWER

---

This system can utilize external signals coming from navigation equipment, net recorder, echo sounder, etc. Ensure that all these machines operate properly before turning on this system.

## 4. DESCRIPTION OF CONTROL PANEL

This chapter provides rough description of operating controls and keys on the control panel. Numbers in brackets denote reference pages. As the operator becomes familiar with operation, you can easily operate this system referring to this page and the display selection guide table on page 17.

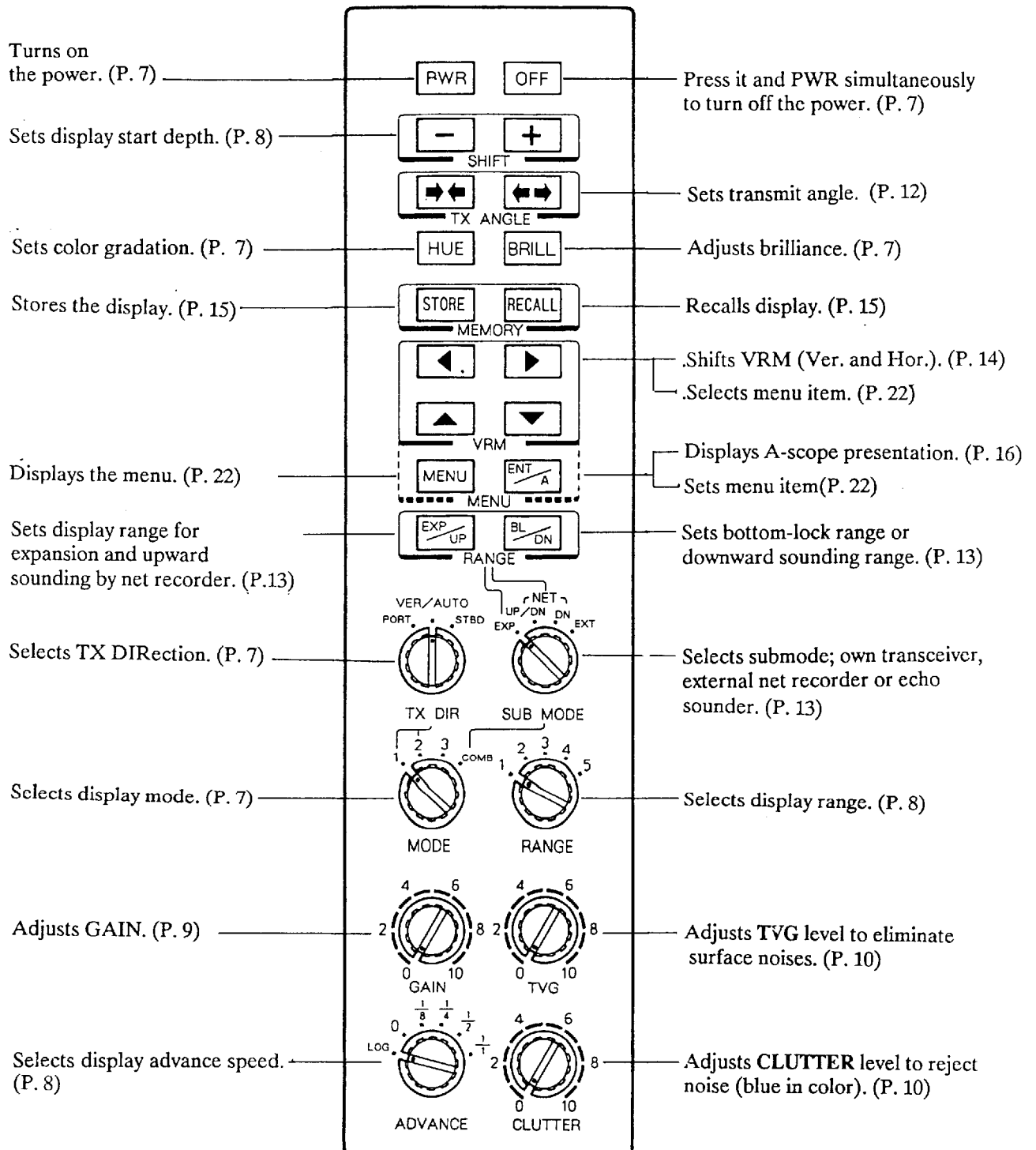

---

## 5. DISPLAY MODES

---

The FCV-10 provides eight display modes to meet the requirements of fishing methods and conditions.

### Variety of Displays

---

Below are the eight display modes. All display modes appear on the quick display selection table on page 17 which shows you how to select a display mode by the display **MODE** selector, **TX DIR** selector and **SUB-MODE** selector.

<b>VERTical display</b>	presents echoes by sounding vertically like conventional color video sounders. This unit transmits ultrasonic sounds in three directions of port, vertical, and starboard.
<b>PORT display</b>	presents echoes sounded towards port.
<b>STBD (Starboard) display</b>	presents echoes sounded towards starboard.
<b>AUTO scan display</b>	presents echoes sounded towards between port and starboard.
<b>EXTernal echo sounder display</b>	presents echoes sounded by external echosounders connected to the display unit. Selection of the display is done on the <b>DISPLAY</b> menu screen. For further details, see page 26.
<b>NET UP/DN and DN displays</b>	presents echoes by upward and downward soundings of the connected net recorder.

### Example of Display Selection

---

- 1) Select the desired display by referring to the quick display selection table on page 17. For example, select the display of vertical and starboard soundings for observation of underwater situation in two directions.
- 2) Since this is a 2-display screen, set the **MODE** selector to the **2** position.
- 3) The **TX** direction is starboard, so select **STBD** with the **TX DIR** selector.

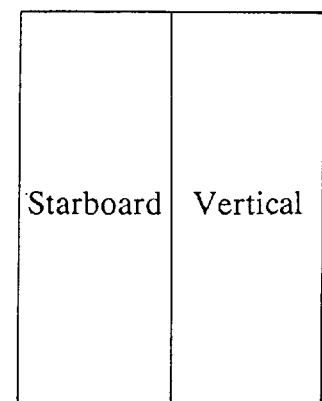

Ex. Two display mode

---

## 6. OPERATION

---

The FCV-10 is simple to operate. Most major functions can be set with a single key stroke or selector setting. When you become familiar with the unit, you can operate it referring to the separate operation guide sheet.

---

### Turning Power On/Off

---

- PWR key** Press the **PWR** key to turn on the power. The unit will commence transmission and display echoes on the CRT screen in a few seconds.
- PWR, OFF keys** Press the **PWR** and **OFF** keys simultaneously to turn off the unit.

---

### Adjusting Brilliance

---

- BRILLiance key** The **BRILL** key adjusts the picture brilliance in four steps; **1, 2, 3, 4** and the value selected appears in large letters for two seconds. To extend the life of the CRT use moderate brilliance.

---

### Selecting Combination of Display Colors

---

- HUE key** The **HUE** key changes the arrangement of display colors. Every pressing changes it in eight steps to match surrounding lightness.

---

### Selecting Display RANGE

---

- RANGE selector** The **RANGE** selector sets the basic RANGE from the five ranges tabulated below. These ranges are the factory-set values. You can customize the BASIC range depending on your requirement. See page 27 for DEPTH RANGE menu.

Position	1	2	3	4	5
Range	100 m	200 m	500 m	1000 m	1500 m



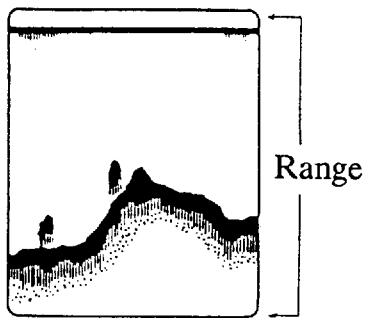

## Shifting Range

---

### Shift + - keys

The **SHIFT + -** keys set the start depth of the display. Note that continuous pressing of the keys accelerates the rate of change. (End depth: Max. 6000 m)

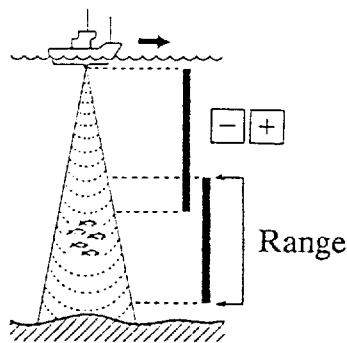

## Display Advance Speed Selection

---

### ADVANCE selector

The **ADVANCE** selector sets the display advance speed from 1/1, 1/2, 1/4 or 1/8.

At the fastest speed (1/1) echoes are horizontally expanded. The slowest speed (1/8) provides longer observation period. The **0** position stops picture advancement to observe echoes closely, or take a photograph of the display.

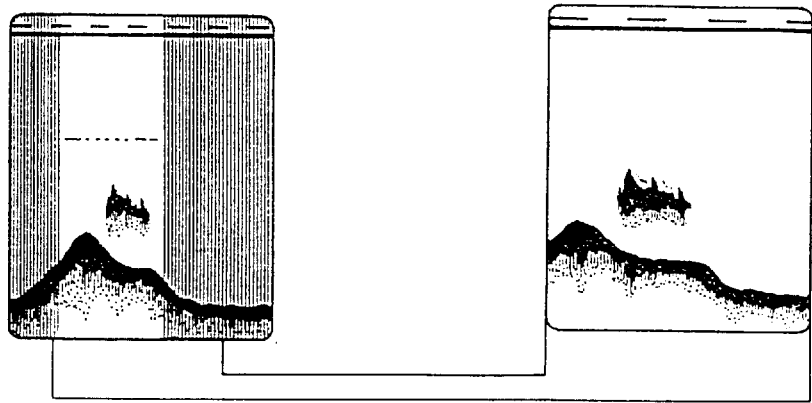

The **LOG** position, operative when a log pulse is available from a speed log, a current indicator, or navigation equipment, sets the display advance speed according to ship's speed.

In this position, the display advance rate changes automatically in proportion to ship's speed. The illustration below shows that the horizontal scale of the display is not influenced by the change of ship's speed, permitting judgement of fish school size and abundance.

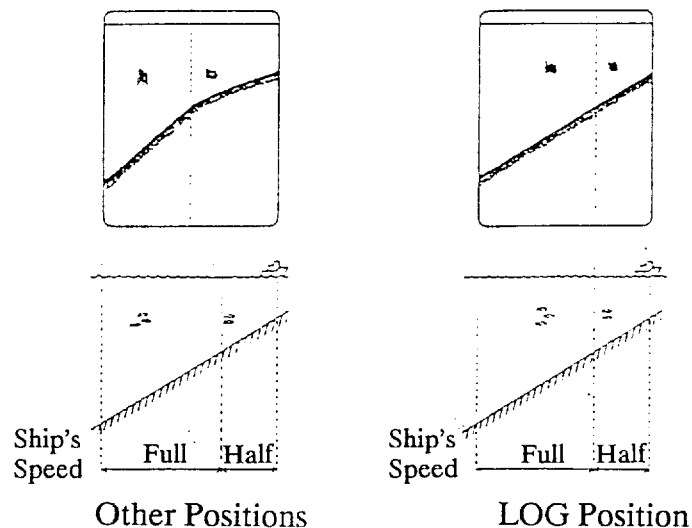

## Adjusting GAIN

### GAIN control

The **GAIN** control adjusts the sensitivity of the receiver. Set it to the point just below where weak noise disappears from the screen. Detected echoes are painted in reddish to bluish colors according to their intensity. The seabed and large fish schools are drawn in reddish color, and the seabed tail and small fish echoes in bluish color. Normal setting is between 3 and 5. Note that the color of echoes will change when the **HUE** key is pressed.

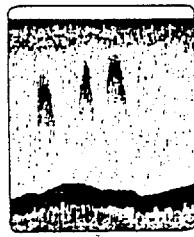

Too high

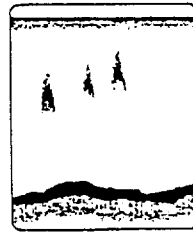

Proper

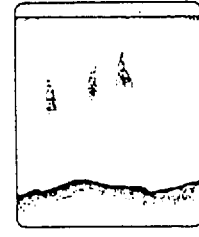

Too low

## Adjusting TVG

---

### TVG control

The **TVG** control compensates for propagation attenuation of the ultrasonic pulses. It equalizes echo presentation in color level so that the fish schools of the same size appear in the same density in both shallow and deep waters. In addition, it also helps to eliminate surface noise, which may mask shallow targets.

For normal operation, set the **TVG** control between 3 and 5. Too excessive setting of the **TVG** may eliminate the desired echoes. If the **TVG** curve is not suitable for your fishing, you can change it using the **RECEIVER** menu. See page 25.

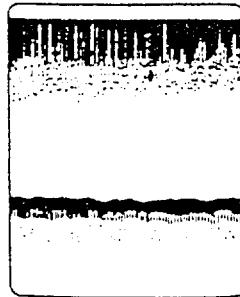

Improper

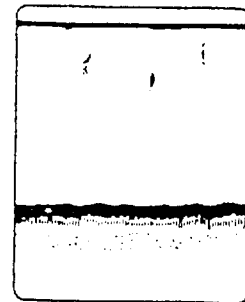

Proper

## Removing Clutter

---

### CLUTTER control

Turn the **CLUTTER** control clockwise if blue dots (noise caused by contaminated water) appear on the whole screen. Additionally adjust it whenever the **TVG** is adjusted. Normally set it between 0 and 2. Note that some forms of noises cannot be eliminated.

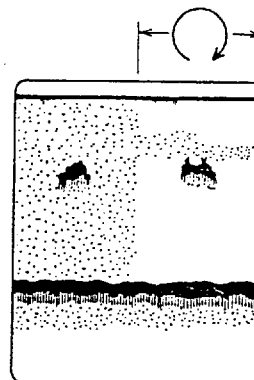

## Selecting Display Mode

---

As noted earlier the FCV-10 has a wide variety of display modes. This section shows you how to select display modes. Also refer to the quick display selection table on page 17.

*Note: The display unit is shipped with the screen split vertically. If you prefer horizontally divided screen, select it on the DISPLAY menu. See page 26.*

### MODE selector

The **MODE** selector selects the display mode as shown below.

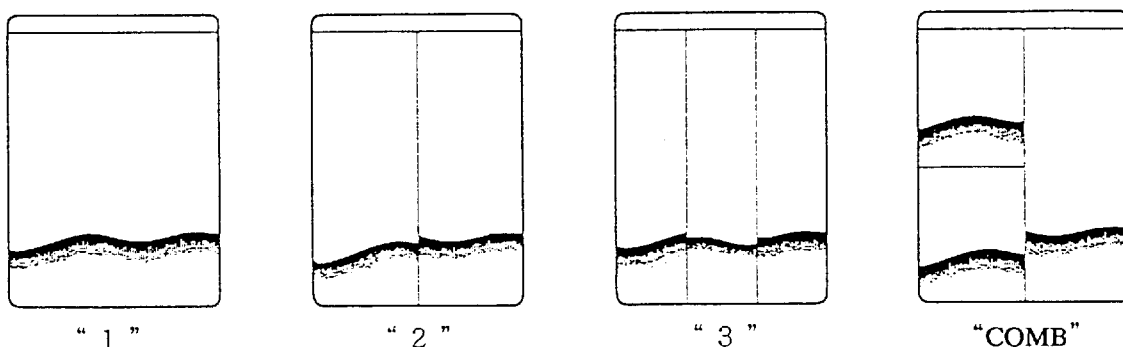

### MODE 1

One-screen display of echoes detected by the sounding beam in the direction of **VERTical**, **PORT**, or **STBD** (starboard), selected by the **TX DIR** selector.

### MODE 2

The right screen displays echoes detected by the vertical sounding beam, and the left, echoes detected by the sounding beam selected by the **TX DIR** selector.

### MODE 3

The three-display picture shows echoes detected by the port, vertical and starboard soundings on the left, center and right screens, respectively.

### MODE COMBination

The combination display mode gives you vertical sounding plus **EXPan**sion, **NET UP/DN** (net recorder upward and downward) and **NET DN** (downward) displays, which you can select by the **SUB MODE** selector.

## Selecting Sub-Mode Display

---

### EXPansion mode

This position presents an expansion display on whole or half of the screen as selected on the RANG menu. See page 27.

### NET UP/DN (Net recorder upward and downward sounding mode)

This position plots echoes on the left screen which are detected by upward and downward soundings of the connected net recorder.

### NET DN (Net recorder downward sounding mode)

This position plots echoes on the left screen which are detected by downward sounding of the connected net recorder.

### EXTernal echo sounder mode

This position plots echoes detected by external echo sounders connected to the display unit.

## Selecting Transmit Direction

---

### **TX DIR selector**

The **TX DIR** selector chooses the sounding direction among vertical, port, starboard, and auto scan soundings. This selection is necessary when the **MODE** selector is set to **1** or **2** (one- or two- screen display).

### AUTO SCAN Mode

In this mode, the sounding beam is automatically scanned between the selected directions in port and starboard. This mode is useful for observing the distribution of fish in a wide area. The figure below illustrates the concept of the **AUTO SCAN** mode.

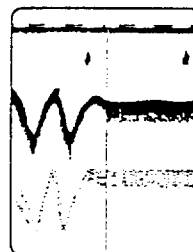
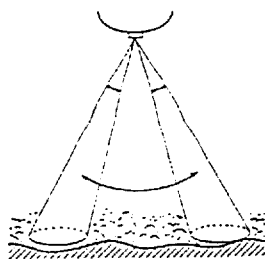

## Selecting Transmit Angle

### TX ANGLE key

The FCV-10 uses three sounding beams: port, starboard and vertical. The **TX ANGLE** keys set transmit directions of port and/or starboard sounding beams in one degree steps up to 16 degrees relative to the vertical. The transmit directions are shown by arrows and angles at the top of the display.

*Note: When ROLL CALIB is set to OFF on the TRANSMITTER menu, maximum TX angle is 32 degrees instead of 16 degrees. See page 24.*

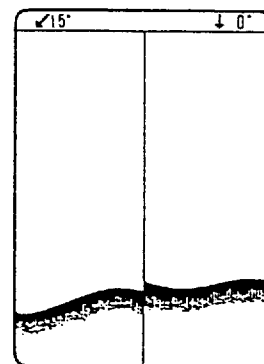
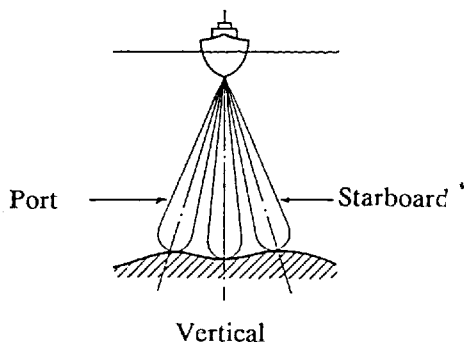

Ex. Two Display Mode

## Selecting Range for Expansion and Bottom-locked Display

### MODE and SUB MODE selectors

Set the **MODE** selector to the **COMB** position and the **SUB MODE** selector to the **EXP** position to display a zoom or bottom-locked expansion display. The expansion display range may be adjusted by the **EXP/UP** and **BL/DN RANGE** keys. The display range appears on the expansion display for two seconds. Note that the depth range scale is calibrated automatically.

The bottom-locked display function operates only when the bottom is detected at certain level. Note that the bottom cannot be detected in the water with air bubbles and if the bottom is steep or muddy.

### Pelagic Expansion Display

#### EXP/UP key

The **EXP/UP** key sets the range for marker zoom (M/Z) and bottom zoom (B/Z) displays. The start depth of the display may be set by the **VRM** up and down keys.

Position	1	2	3	4	5
Expansion Range	5 m	10 m	20 m	40 m	80 m

#### BL/DN key

The **BL/DN** key sets the expansion range of the bottom-locked display.

**BL/DN key**

The BL/DN key sets the expansion range of the bottom-locked display.

Position	1	2	3	4	5
Bottom-lock Range	5 m	10 m	20 m	40 m	80 m

### Selecting Net Recorder Display Range

---

**MODE and SUB MODE selectors**

Set the **MODE** selector to the **COMB** position and the **SUB MODE** selector to **NET UP/DN** or **DN** position to get the net recorder display (on the left display screen). To adjust the display range, use the **EXP/UP** and **BL/DN RANGE** keys. The display range appears on the expansion display for two seconds.

#### Net Recorder Upward Sounding Display Range

**EXP/UP key**

The EXP/UP key selects the upward range of the net recorder.

Position	1	2	3	4	5	6	7	8
Net Recorder Upward Range	10 m	20 m	120 m	180 m	280 m	400 m	500 m	600 m

#### Net Recorder Downward Sounding Display Range

**BL/DN key**

The BL/DN key sets the downward range of the net recorder.

Position	1	2	3	4	5	6	7	8
Net Recorder Downward Range	5 m	10 m	20 m	40 m	60 m	120 m	180m	400 m

### Using the Vertical and Horizontal VRMs

---

**VRM keys**

This unit provides two types of **VRMs** (Variable Range Marker): one vertical and one horizontal VRMs. The VRMs function to measure the depth or range to a fish school, by moving the horizontal or vertical VRM with right/left and up/down arrow keys.

#### Measuring Depth to a Fish School

**VRM UP/DOWN keys**

Move the horizontal **VRM** marker onto a fish school with the up/down arrow keys. The depth to the fish school is digitally shown above the marker.

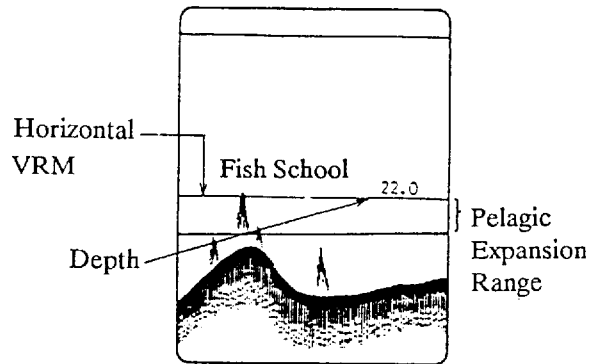

### Measuring Horizontal Distance to a Fish School

#### **RIGHT and LEFT arrow keys**

Move the vertical **VRM** marker onto a fish school with the right/left arrow keys. The horizontal distance to the fish school is digitally shown at the lower left-hand corner of the display.

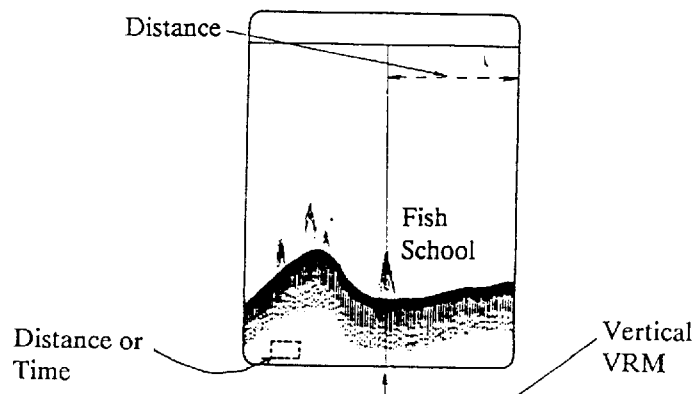

*Note: To display distance ship's speed data should be entered from the connected speed log or navigational equipment. If unavailable, elapsed time after passing over the point of the vertical VRM marker is displayed instead.*

### Storing/Recalling Picture

This equipment is capable of storing the current display in its memory for later reference and study.

#### Storing the Display

#### **STORE key**

Press the **STORE** key to store the current display in the memory. **STORE** appears on the screen during the storing process. At the same time, an orange color vertical line appears on the screen and advances with the display to mark the position where the **STORE** key was pressed.



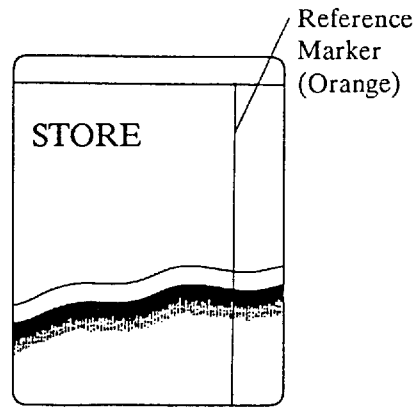

### Recalling the Stored Display

#### **RECALL key**

Press the **RECALL** key to recall the stored display. To restore normal operation, press the **RECALL** key.

*Note 1: The display stored in the memory is erased each time the STORE key is pressed or the power is turned off.*

*2: The color of the marker line may change when the HUE key is pressed to change the display color.*

### A-Scope Presentation

#### **ENT/A key**

The A-scope presentation provides for detailed presentation of fish echoes. Press the **ENT/A** key to enable the A-scope presentation. Since fish echoes are displayed with varying amplitudes and colors according to echo strength, the discrimination of bottom fish and their density become easier.

To return to the previous mode, press the **ENT/A** key again.

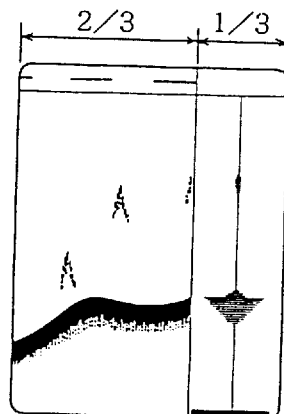

③ Quick Display Selection Table (MODE, TX DIR, SUB MODE Selectors)

Sp TX Dir Mode	Horizontally Split Screen (Set by Menu display, P.26)				Vertically Split Screen (Factory Setting)															
	Port		Ver/Auto		STBD (Starboard)		Port		Ver/Auto		STBD (Starboard)									
1	Port 0- 25- 50- 75- 100-		Vertical 0- 25- 50- 75- 100-		STBD 0- 25- 50- 75- 100-		Port 0- 25- 50- 75- 100-		Vertical 0- 25- 50- 75- 100-		STBD 0- 25- 50- 75- 100-									
2	Vertical 0- 50- 100- Port 0- 50- 100-		Vertical 0- 50- 100- Auto 0- 50- 100-		Vertical 0- 50- 100- STBD 0- 50- 100-		Port 0- 25- 50- 75- 100- Vertical		Auto 0- 25- 50- 75- 100- Vertical		STBD 0- 25- 50- 75- 100- Vertical									
3	<table border="1"> <tr><td>Port</td><td>0- 100-</td></tr> <tr><td>Vertical</td><td>0- 100-</td></tr> <tr><td>STBD</td><td>0- 100-</td></tr> </table>				Port	0- 100-	Vertical	0- 100-	STBD	0- 100-	<table border="1"> <tr><td>Port</td><td>0- 25- 50- 75- 100- Vertical</td></tr> <tr><td>Vertical</td><td>0- 25- 50- 75- 100- Vertical</td></tr> <tr><td>STBD</td><td>0- 25- 50- 75- 100- Vertical</td></tr> </table>				Port	0- 25- 50- 75- 100- Vertical	Vertical	0- 25- 50- 75- 100- Vertical	STBD	0- 25- 50- 75- 100- Vertical
Port	0- 100-																			
Vertical	0- 100-																			
STBD	0- 100-																			
Port	0- 25- 50- 75- 100- Vertical																			
Vertical	0- 25- 50- 75- 100- Vertical																			
STBD	0- 25- 50- 75- 100- Vertical																			
SUB Mode	Expansion		NET UP/DN		NET DN		External Echosounder		Expansion		NET UP/DN		NET DN		External Echosounder					
COMB (Factory Setting)	Bottom-lock 10- 5- 0-		Vertical 0- 50- 100- Net Up 0- 10- Net Down 0- 5-		Vertical 0- 50- 100- Net 0- 2.5- Down 5-		Vertical 0- 50- 100- ES 1 0- 100- ES 2 0- 100-		Bottom-lock 10- 5- 0-		Net Up 10- 5- 0- Net Down 0- 2.5- 5- Vertical 0- 25- 50- 75- 100-		Net Down 0- 2.5- 5- Vertical 0- 25- 50- 75- 100-		ES 1 0- 100- Vertical 0- 25- 50- 75- 100- ES 2 0- 100- Vertical 0- 25- 50- 75- 100-					
COMB (Change with Menu Display, P.27)	Vertical 0- 50- 100- Bottom-lock 50- 60- 70-		Vertical 0- 50- 100- Marker zoom 50- 60- 70-		Vertical 0- 50- 100- Bottom zoom 10- 5- 0-		Vertical 0- 50- 100- ES2 50- 100- ES1 50- 100-		Bottom-lock 50- 60- 70- Vertical 0- 25- 50- 75- 100- Marker zoom 50- 60- 70- Vertical 0- 25- 50- 75- 100-		Bottom zoom 10- 5- 0- Vertical 0- 25- 50- 75- 100- ES1 0- 25- 50- 75- 100- Vertical 0- 25- 50- 75- 100-		ES2 0- 25- 50- 75- 100- Vertical 0- 25- 50- 75- 100- ES1 0- 25- 50- 75- 100- Vertical 0- 25- 50- 75- 100-							

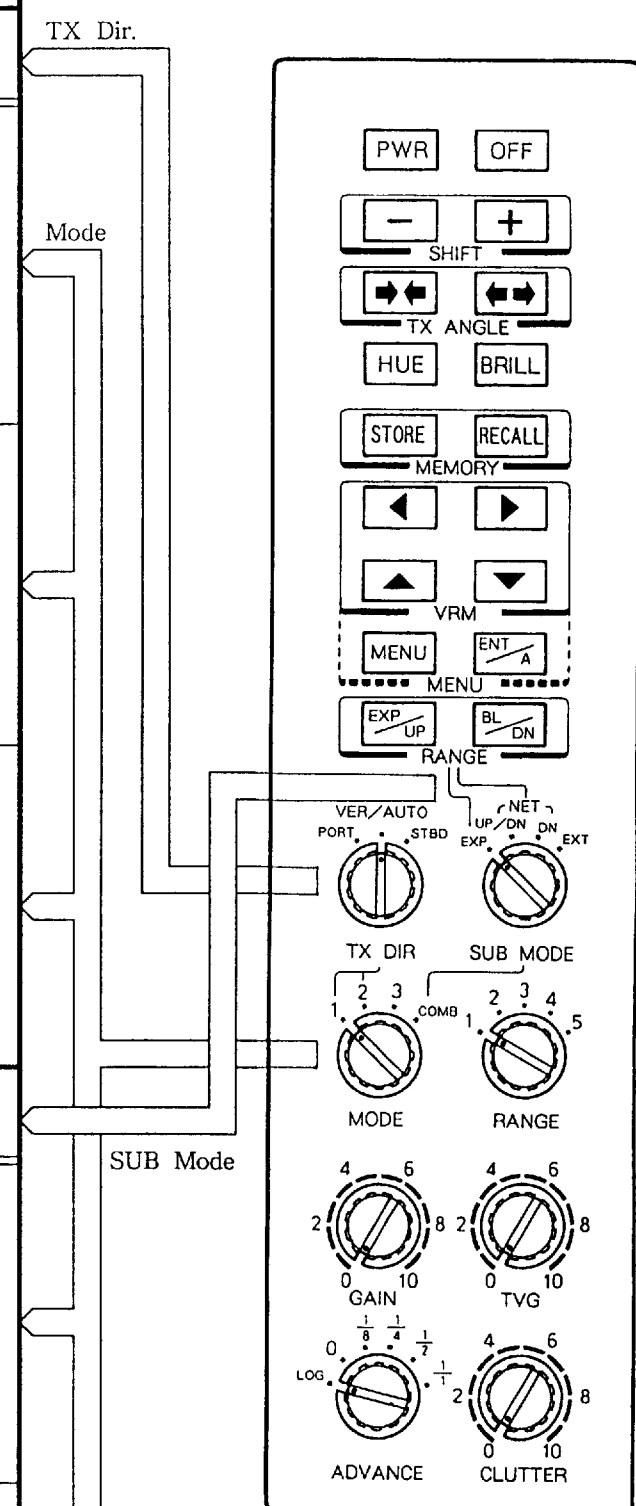

Note : For A-scope presentation, press ENT/A

# 7. INTERPRETING THE DISPLAY

## Example of Display (3- Display Mode)

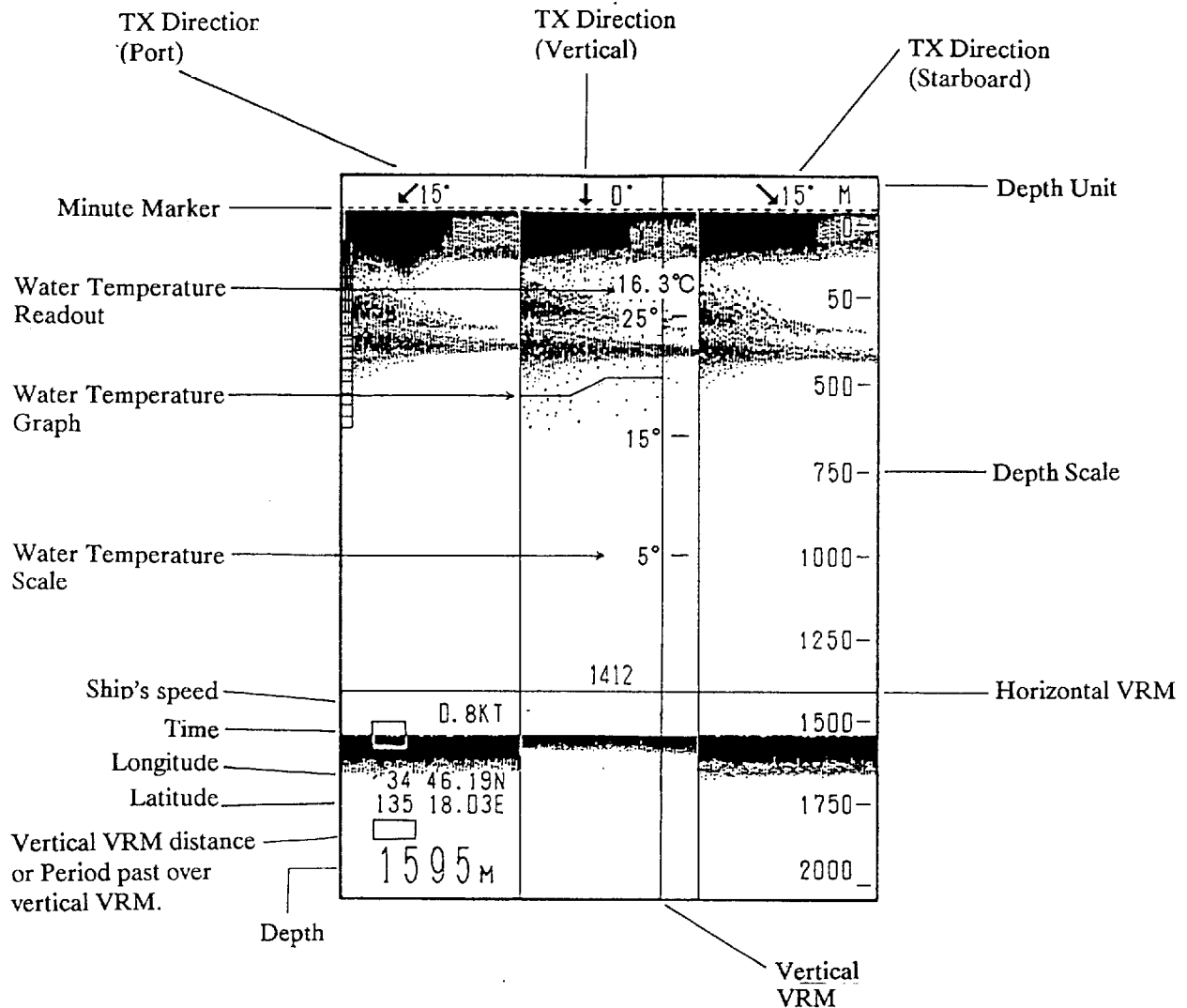

The above illustration shows the location of every marker and indication which appear on the display. Explanation is given for items not previously mentioned.

- Minute Marker** Shows one minute by a 30-second mark and 30-second space.
- Time, Ship's Speed** Appears when navigation equipment or speed log is connected to the display unit.
- Ship's position** Indicated in latitude and longitude, if navigation equipment is connected.
- Depth** Measured by the vertical sounding beam.

<b>Water Temperature Scale</b>	Appears when a water temperature indicator is connected to the display unit. Changes automatically according to the temperature among -5 to 15 °C, 5 to 25 °C, 15 to 35 °C.
<b>Water Temperature Readout</b>	Indicates water temperature.
<b>Water Temperature Graph</b>	Plots change of water temperature with a continuous line.

## Scanning Area of Sounding Beams

The **FCV-10** scanbeam sounder is provided with the scanning function of sounding beams in port and starboard directions. In this section, the detecting area by scanning sounding beams is explained. .

### **One sounding beam**

When the **MODE** selector is set to "1", the sounding beam is directed vertically. The beam is 10 degrees (port-starboard) by 9.5 degrees (fore-aft) wide, covering an area of 17.5 m by 16.5 m at 100 m depth.

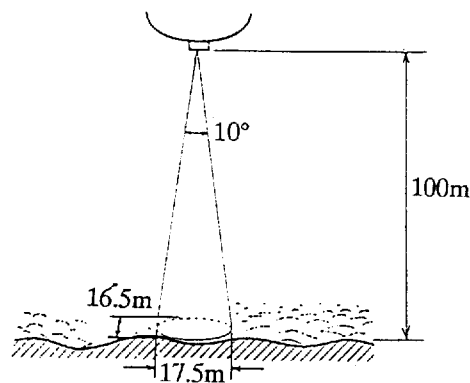

### **Two sounding beams**

With the **MODE** selector set to 2 and the **TX DIR** selector to **PORT**, another sounding beam is added in the port direction. In the example at the top of the next page, it directs towards port 10 degrees. By this addition, the sounding beam is widened to 20 degrees by 9.5 degrees and its detecting area is 35 m by 16.5 m at 100 m depth. Compared to sounding by a single beam with similar beamwidth, this has an advantage of better resolution of fish school location because fish schools detected by respective sounding beams are displayed on the respective screens. It may be utilized to observe how fish school and shoal are distributed or shaped and also how bottom condition changes.

*Note : Since echoes from a flat seabed become weaker when they are of the slanted sounding beams, be careful not to judge its hardness simply from display colors.*

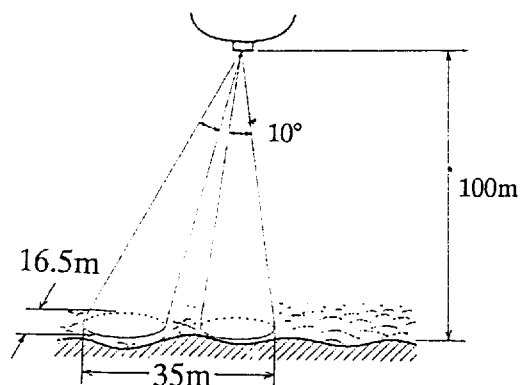

**Three Sound-  
ing Beams**

When the **MODE** selector is set to the **3** position, another beam of 10 degrees wide is added to the previous mode. Then the total beam width is 30 degrees x 9.5 degrees, and effective for general searching.

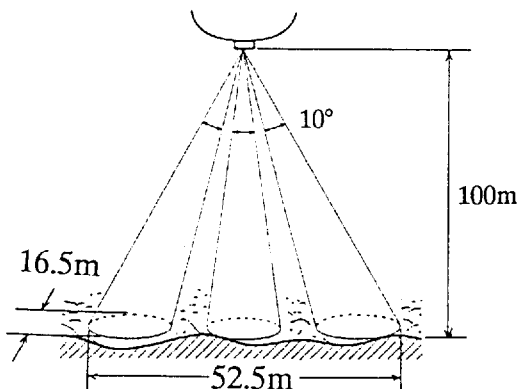

**AUTO scanned  
beam**

When the **MODE** selector is set to the **2** position and the **TX DIR** selector **VER/AUTO**, the sounding beam scans in steps of 1 degree or 2 degrees between port and starboard like a single beam searchlight sonar. This mode is useful for examining the nature of a of shoal and distribution of fish. Note that it takes about 9.6 seconds for 1 degree-step scanning with the **RANGE** set to **100 m** to scan from port 16 degrees to starboard 16 degrees. Also the scanning speed becomes slower as the **RANGE** is increased.

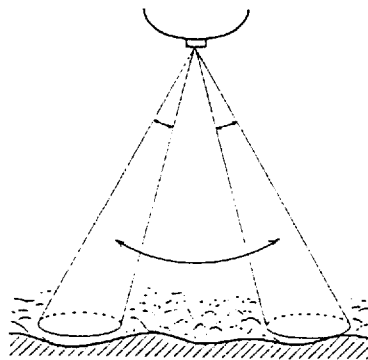

Note: The scanning step can be set for 1 or 2 degrees with the DEPTH RANGE menu. See page 27.

## Using Three Direction Combination Display

When the MODE selector is set to the 3 position, the vertical, port and starboard displays appear on the entire screen irrespective of the TX DIR selector setting. The two features of this mode are explained referring to Example 2 below.

### Distribution of Fish

The port and vertical displays detect fish but the port display does not. This means you should steer your ship in the port direction.

### Shape of Bottom

The starboard display draw the longer tail for the bottom than the port display, indicating a hard bottom. The vertical display shows the bottom with the shortest tail, because it is detected with the narrower sounding area by the vertical sounding beam in comparison with by the slant port and starboard sounding beams. Also the port and starboard displays can show the inclination of the bottom by reading each depth.

## False Echo by Sidelobe of Sounding Beam

The ultrasonic beam comprises the main lobe and other sidelobe components. Most of the ultrasonic energy is contained in a main lobe; but some energy is transmitted in unwanted direction as sidelobes. If the sidelobe can detect the bottom and fish with a sufficient echo level, false echo by a sidelobe is displayed like Example 2.

Example 1

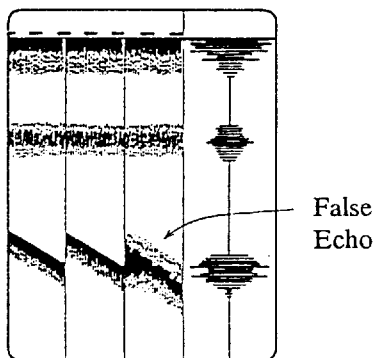

Example 2

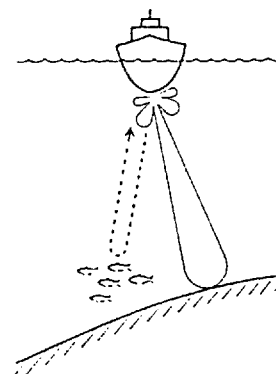
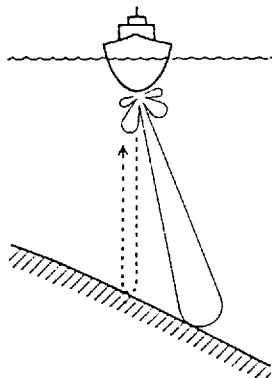
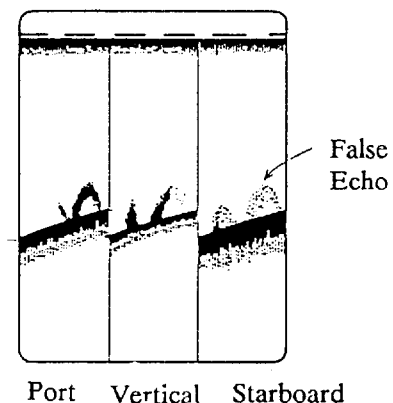

---

## 8. CHANGE OF OPERATING MODE BY MENU

---

### Basic Operation

---

The **MENU**s of the FCV-10 let you change the operating mode from the factory settings to meet your demand, fishing ground condition, method, etc. There are four menus: **INIT**ial, **TX**, **RX**, **DIS**Play and **RAN**Ge.

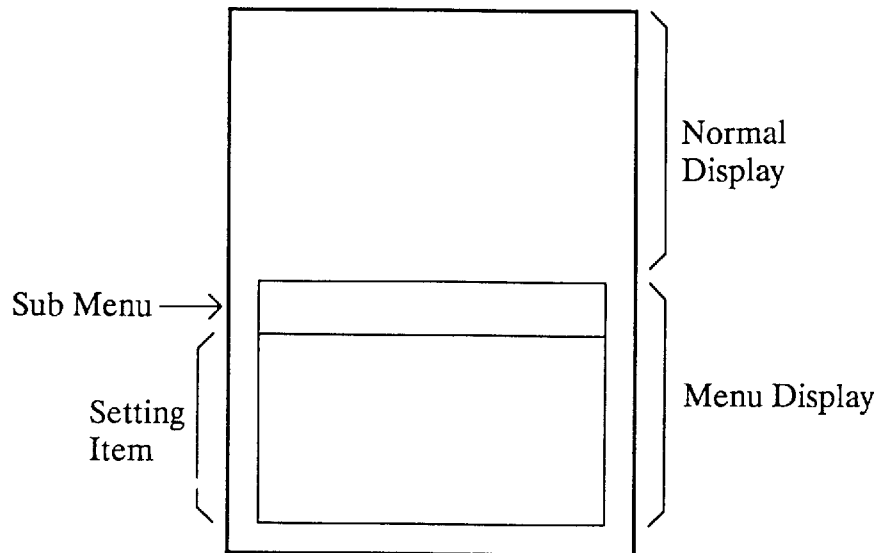

### Procedure

- 1) Press the **MENU** key. The **INIT**ial menu appears on the lower half of the screen.
- 2) Press the up and down arrow keys to move the longer cursor to the **MENU SELECT** position.
- 3) Select a submenu by moving the shorter cursor to the desired submenu (**INIT**, **TX**, **RX**, **RANG**) with the right and left arrow keys.
- 4) Press the **ENT/A** key. The selected submenu is highlighted and items of the submenu appear below the **MENU SELECT** row.
- 5) Move the shorter cursor to the item to be changed, by pressing the up, down, right and left arrow keys. Details of the items are given on the following pages.
- 6) Press the **ENT/A** key to register selection.
- 7) To change other items, repeat the steps 5 and 6.
- 8) After making selection, press the **MENU** key. Control is returned to the previous display.

## INITIAL Menu

The INITIAL menu contains items which are set during installation, and thus does not require frequent readjustment.

M E N U						
MENU SELECT	:	INIT	TX	RX	DISP	RANG
UNIT	:	M	FT	FA	HIRO	
I/O FORMAT	:	CIF	NMEA			
NAV INPUT	:	LC	LA	DR	GPS	OTHR
POSI DATA	:	L/L	TD			
LOG INPUT	:	OFF	200P	300P	400P	500P
ROLL-ANG ADJ	:	L4°	L2°	0°	R2°	R4°
ROLL-AMP ADJ	:	-10%	-5%	0%	+5%	+10%
MOVE CURSOR WITH ▲▼ OR ◀▶, THEN HIT <b>ENT</b> KEY. HIT MENU KEY TO RETURN NORMAL DISPLAY.						

- UNIT** Unit of depth measurement: **M** (meter), **FT** (Feet), **FA** (Fathom), **HIRO** (Japanese Fathom)
- I/O FORMAT** selects the format {**FURUNO CIF** or **NMEA** (NMEA0183)} of the communication data fed from or sent out to external devices such as navigation equipment.
- NAV INPUT** selects the device to feed position data: **LC** (Loran C navigator), **LA** (Loran A navigator), **DR** (Dead reckoning position made by a gyrocompass and a speed log), **GPS** navigator and **OTHR** (other navigation equipment).
- POSI DATA** selects the ship's position data measurement system: **L/L** (Latitude/Longitude), **TD** (Time difference measured by a Loran navigator).
- LOG INPUT** selects the speed data source; **OFF** (No entry of pulsed speed data), **200Pulses/n.m.**, **300P**, **400P**, **500P**.
- Note 1: The log mark is plotted on the optional recorder unit FE-1280 only.*  
*2: When the OFF position is selected, a digital speed data in CIF or NMEA format is fed from navigation equipment.*
- ROLL-ANG ADJ** compensates for mounting inclination of the transducer in port and starboard directions.
- ROLL-AMP ADJ** compensates for siting deviation of the clinometer from its best mounting location. Refer to page 48.



## TRANSMITTER Menu

Normally these items may not be changed after installation. If you would sail a different fishing ground or catch a different species of fish, these items may be changed by the operator.

M E N U						
MENU SELECT	:	INIT	<b>TX</b>	RX	DISP	RANG
SCAN SPEED	:	<b>HIGH</b>	STD			
SCAN STEP	:	<b>1°</b>	2°			
ROLL CALIB	:	<b>ON</b>	OFF			
TX OUTPUT	:	1	2	3	<b>4MAX</b>	
SIDE LOBE	:	<b>MIN</b>	MAX			
TX PRR	:	<b>STD</b>	LOW			
MOVE CURSOR WITH ▲▼ OR ◀▶, THEN HIT <b>ENT</b> KEY. HIT MENU KEY TO RETURN NORMAL DISPLAY.						

- SCAN SPEED**                    **HIGH** (Alternates vertical and simultaneous port/starboard soundings), **STD** (Vertical to port to starboard to vertical successive sounding).
- SCAN STEP**                    selects the scanning step for the sounding beam in the auto scanning mode: 1 degree or 2 degrees.
- ROLL CALIB**                    enables and disables compensation for ship's rolling by the clinometer. If set to **ON**, the adjustable range of the TX angle changes from 36 degrees to 16 degrees for both port and starboard.
- TX OUTPUT**                    selects transmitter output power emitted from the transducer. The 4 position is for the maximum output. In shallow waters, select the lower power (**1, 2 or 3**) to avoid unwanted surface noises.
- SIDELOBE**                      selects the level of the sidelobe of the transmitting signal. The **MAX** position is proper for discrimination of ground quality.
- TX PRR**                         selects the number of transmitting pulses per minutes. The **STD** position is for the standard setting. If the second reflection appears on the screen, however, select the **LOW** position to eliminate it.

## RECEIVER Menu

These items may be changed in accordance with fishing ground and fishing method, etc. Set them for distinct echo presentation.

M E N U					
MENU SELECT	:	INIT	TX	<b>FX</b>	DISP RANG
ES IR	:	<b>OFF</b>	1	2	
NET IR	:	<b>OFF</b>	1	2	
EXTERNAL KP	:	<b>OFF</b>	ON		
ATTENUATOR	:	<b>OFF</b>	1	2	3
TVG CURVE	:	<b>1</b>	2	3	4
TVG RANGE	:	1	2	<b>3</b>	4 5FAR
BEAM WIDTH	:	<b>WIDE</b>	NAR		
MOVE CURSOR WITH ▲▼ OR ◀▶, THEN HIT <b>ENT</b> KEY. HIT MENU KEY TO RETURN NORMAL DISPLAY.					

**ES IR** sets the degree of interference rejection from other echo sounders and sonar. The **2**-position may reject weak echoes as well as unwanted ones.

**NET IR** rejects unwanted noise appearing on the net recorder display.

**EXTERNAL KP** synchronizes transmission with another echo sounder installed onboard to prevent mutual interference.

*Note: To use this function, the keying pulse from another echo sounder should be applied to the FCV-10.*

**ATTENUATOR** If the intensity of seabed and fish echoes is too high with the **GAIN** control set to the minimum position, increase this value to decrease receiver sensitivity.

**TVG CURVE** presets the **TVG** curve. The higher the setting the greater the **TVG** effect. Change the position according to your fishing ground and method: **1** for 20log R curve suitable for seabed and large fish school detection, **2** for 20log 2R, **3** for 30log R, **4** for 40log R suitable for a single fish and small fish school detection.

**TVG RANGE** sets both the **TVG** start depth (from 1 to 5 meters), and **TVG** effective range. Note that the **TVG** effective range is determined by combination of **TVG CURVE** and **TVG RANGE** settings. If, for example, the **TVG RANGE** is set to 3, the effective ranges are; 700 m for 20log R, 350 m for 20 log 2R, 75 m for 30log R and 30 m for 40 log R.

**BEAMWIDTH** 10 degrees for **WIDE**, 6 degrees for **NAR**row.

## DISPLAY Menu

These items may be changed locally on your requirements.

M E N U					
MENU SELECT	:	INIT	TX	RX	DISP RANG
SPLIT SCREEN	:	VERT	HOR		
DEPTH SCALE	:	BOTH	DEPTH	OFF	
SLANT CALIB	:	ON	OFF		
EXP MARKER	:	ON	OFF		
LEGEND	:	ON	OFF		
EXT SEL	:	1 - 2	1	2	
CHARACTER	:	和文	ENG		
MOVE CURSOR WITH ▲▼ OR ◀▶, THEN HIT <span style="border: 1px solid black; padding: 2px;">ENT</span> KEY. HIT MENU KEY TO RETURN NORMAL DISPLAY.					

- SPLIT SCREEN**            **VERT**ically or **HOR**izontally divided.
- DEPTH SCALE**            **BOTH** (Temperature and depth scale displayed), **DEPTH** (Depth scale displayed), **OFF** (No scale displayed)
- SLANT CALIB**            **ON** (Slant ranges to a seabed measured by port and starboard soundings are converted into true sea depth.), **OFF** (Slant ranges are displayed. These are greater than a true depth because of longer sounding paths of ultrasonic pulse.)
- EXP MARKER**            **ON** (The pelagic and bottom-locked expansion ranges are shown with marker lines on the vertical display.), **OFF** (No expansion range marker)
- LEGEND**                    turns **ON** and **OFF** digital display of ship's speed, ship's position in latitude/longitude, date, and time data fed from external devices if connected.
- EXT SEL**                    selects either or both external echo sounders, if connected, which are monitored on the left screen: **1** (#1 echo sounder), **2** (#2 echo sounder), **1.2** (#1 and 2 echo sounders).
- CHARACTER**                selects display language: Japanese or **ENGLISH**.

## RANGE Menu

M E N U						
MENU SELECT	:	INIT	TX	RX	DISP	<b>RANG</b>
RANGE 1	:	100	100	<b>100</b>	120	150
RANGE 2	:	120	150	<b>200</b>	250	300
RANGE 3	:	300	400	<b>500</b>	600	800
RANGE 4	:	600	800	<b>1000</b>	1200	1500
RANGE 5	:	1000	1200	<b>1500</b>	2000	2000
DRAFT	:	<b>+0.0</b>				
EXP MODE	:	<b>B/L-A</b>	B/L-B	M/Z	B/Z	
MOVE CURSOR WITH ▲▼ OR ◀▶, THEN HIT <b>ENT</b> KEY. HIT MENU KEY TO RETURN NORMAL DISPLAY.						

### RANGE 1 to 5

These items let you customize depth ranges.

### DRAFT

Set ship's draft (depth of transducer from sea surface). Setting range is 50.0 to -6.0. Normally set it in positive polarity. When unit of depth readout is changed, re-enter it.

### EXP MODE

Set type of expansion picture which is displayed when **SUB MODE** switch is set to "EXP".

B/L-A: Bottom-lock expansion picture on whole screen.

B/L-B: Normal and bottom-lock expansion picture combination display.

M/Z: Normal and marker zoom picture combination display.

B/Z: Normal and bottom zoom picture combination display.

## Fine Tuning Hue

---

As noted on page 7, you can adjust display hue with the **HUE** key. If you would like to fine tune the hue, follow the procedure below.

### Procedure

- 1) Press the **PWR** and **OFF** keys together to turn off the unit.
- 2) Press the **HUE** and **PWR** keys to enable the **HUE CHANGE** mode.
- 3) Press the **MENU** key. The **HUE CHANGE** menu appears.
- 4) Select the desired brilliance by pressing the **BRILL** key.
- 5) Select the color to be changed; **0** to **F** by pressing the up and down arrow keys.  
(**0**: background color, **F**: reddish brown)
- 6) Move the cursor to the primary color **R** (red), **G** (green) or **B** (blue) by pressing the right and left arrow keys.  
  
*Note: The display color develops with the three primary colors of red, green and blue.*
- 7) Observing the color bar, change the value on the cursor, press the up and down arrow keys while pressing the **ENT/A** key. If the desired color cannot be obtained by a single primary color setting, do the same on other primary colors.
- 8) To set other color levels, repeat the steps 4) to 7) .
- 9) To set other brilliances, repeat the steps 3) to 8).
- 10) After setting the hue to your liking, press the **PWR** and **OFF** keys together to turn off the unit.

### Recovering Factory-set Hue

If the above cannot bear satisfactory results unfortunately, the factory-set hue can be recovered by pressing the **PWR** and **BRILL** keys together.

---

## 9. IF SOMETHING SHOULD GO WRONG WITH YOUR UNIT

---

If you cannot get the unit to operate properly, do the Operation Check below to determine if there is equipment fault. If there is a problem, execute the System Diagnosis (P. 30), and report the results when requesting service.

### OPERATION CHECK

---

#### No Echo Presentation, But Scale Shows.

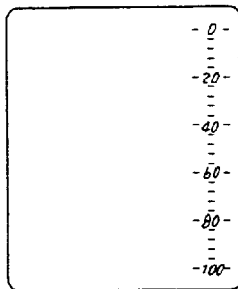

- Is the **ADVANCE** (display advance speed) control set to **0** (stop)? Normal setting is 1/1.
- Is the **ADVANCE** control set to **LOG**? This position requires ship speed signal input which is fed from a speed log or navigation equipment. Also check that they are working properly.

#### No Zero Line

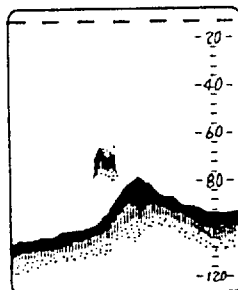

- Is the range shift reading **0**? If the range is shifted several meters or more, the zero line is not displayed. Press the - shift key to move the zero line to 0 meters.

#### Low Sensitivity

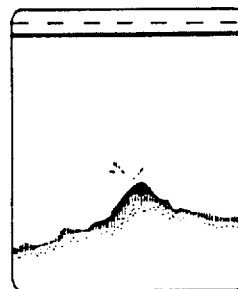

- Is the **GAIN** control set too low?
- Is the **CLUTTER** control set too high?
- Turn the **GAIN** control clockwise or the **CLUTTER** control counterclockwise to increase the receiver sensitivity.

## No Water Depth Readout/Bottom Lock Inoperative

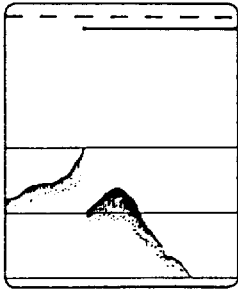

- Is the seabed echo present within the normal display range?
- Is the seabed return strong enough; i.e., red or reddish brown?
- Water depth may not be indicated in the following cases:
  - 1) Seabed return is too weak.
  - 2) Seabed return is interrupted by air foam or a large fish school.
  - 3) Seabed echo is not painted red or reddish brown.

## Display Color Distorted



- Is a magnetic field generator (heavy duty transformer, rectifier, etc.) nearby?
- Picture may become distorted if a machine including a heavy duty transformer is located near the unit.
- Display color may become distorted when echoes are greatly different in intensity.

## SYSTEM DIAGNOSIS (SELF-CHECK)

---

Your unit provides self-check facilities to check it for proper operation.

### Memory ICs (Check 1)

- 1) Turn off the unit by pressing the **PWR** and **OFF** keys simultaneously.
- 2) Turn on the unit by pressing the **-** and **PWR** keys simultaneously. The results of the memory ICs check appear shortly thereafter. Below is an example of check results.

C H E C K 1		
MAIN		
0252037-00		
ROM	OK	
SRAM	OK	
DRAM	OK	
SI01 <-> SI02	NG	
MAIN <-> SUB1	OK	
MAIN <-> SUB2	OK	
SUB1 CPU		
0252038-00		
ROM	OK	
SRAM	OK	
DRAM	OK	
SUB1 <-> SUB2	OK	
SUB2 CPU		
0252039-00		
ROM	OK	
SRAM	OK	

*Note: SI01 <-> SI02 are for factory use only. Therefore the indication NG (No Good) is normal.*

- 3) To terminate the system diagnosis check, turn off the unit by pressing the **PWR** and **OFF** keys simultaneously. Then press the **PWR** key to begin the normal operation again.

### Checking Controls and Keys on the Front Panel (Check 2)

- 1) Turn off the unit by pressing the **PWR** and **OFF** keys simultaneously.
- 2) Press the **PWR** and **ENT/A** keys simultaneously. The display should look something like the figure below.
- 3) Operate each control and key one by one. The corresponding number on the screen changes if the control or key is functioning properly.

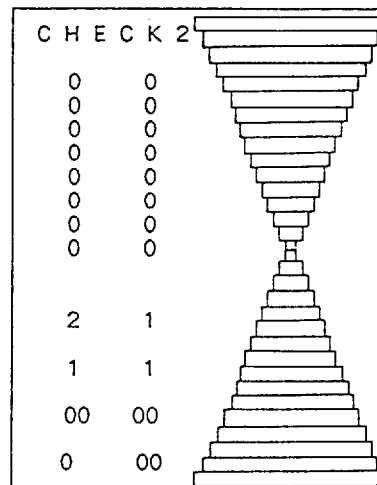

- 4) To terminate Check 2, press the **PWR** and **OFF** keys simultaneously. Then press the **PWR** key to begin the normal operation again.

### Checking With the LED Displays

---

There are several LEDs inside the unit. The status of LEDs give the service technician some hints to bring replacement parts. Therefore it is preferable you open the cover and check the status of LEDs before calling service.

## DANGER

**HIGH VOLTAGE** exists inside the display unit. Precautions must always be exercised when reaching inside the equipment for checking LED status.



### LEDs on MAIN PCB(02P6084)

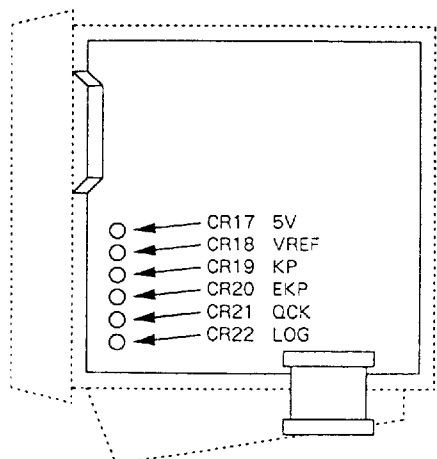

Symbol	Signal	LED Status	Remarks
CR17	5V	Lighting	5V supply for logic ckt.
CR18	VREF	Lighting	Reference voltage +5V for A/D conversion of operating control signals
CR19	KP	Blinking	Every transmission
CR20	EKP	Not lit or Blinking	Keying pulse from external transceivers.
CR21	QCK	Lighting faintly	When HIGH scan speed is selected.
CR22	LOG	Blinking	When ship speed signal is input.

### LEDs on SUB PCB(02P6085)

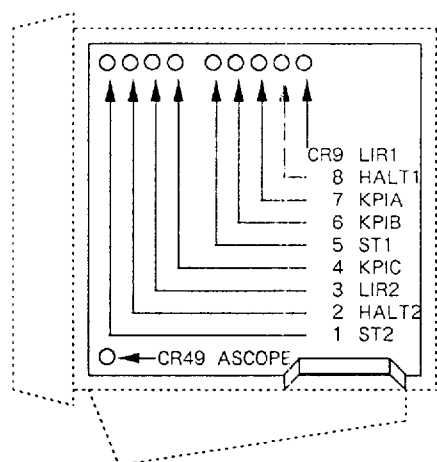

Symbol	Signal	LED Status	Remarks
CR1	ST2	Lighting faintly	Checks CPU on SUB2 board.
CR2	HALT2	Lighting darkly	Checks CPU on SUB2 board.
CR3	LIR2	Blinking	Checks CPU on SUB2 board.
CR4	KPIC	Blinking	By KP. Checks echo acquisition port C.
CR5	ST1	Lighting faintly	Checks CPU on SUB1 board.
CR6	KPIB	Blinking	By KP. Checks echo acquisition port B. (Note)
CR7	KPIA	Blinking	By KP. Checks echo acquisition port A. (Note)
CR8	HALT1	Lighting darkly	Checks CPU on SUB1 board.
CR9	LIR1	Lighting faintly	Checks CPU on SUB1 board.
CR49	ASCOPE	Blinking	By KP. Checks A-scope ckt.

Note: LEDs CR6 and CR7 may not light in some display modes.

## Checking With Demo Display

---

This mode operates the display unit without transceiver unit connection. Thus this mode is useful for judging whether the display unit is operating properly.

### Procedure

- 1) Turn on the unit by pressing the **RECALL** and **PWR** keys. The demo display shown below appears. (**F**: Reddish brown, **0**: Background color)
- 2) The unit checks following key and control functions:
  - **RANGE** control and **SHIFT** key
  - **MODE** switch
  - **ADVANCE** control
  - **CLUTTER** control
  - **STORE** and **RECALL** keys
  - **TX DIR** control (See note 1)
  - **MENU** key
  - A-scope display with the **ENT/A** key
  - **HUE** and **BRILL** keys

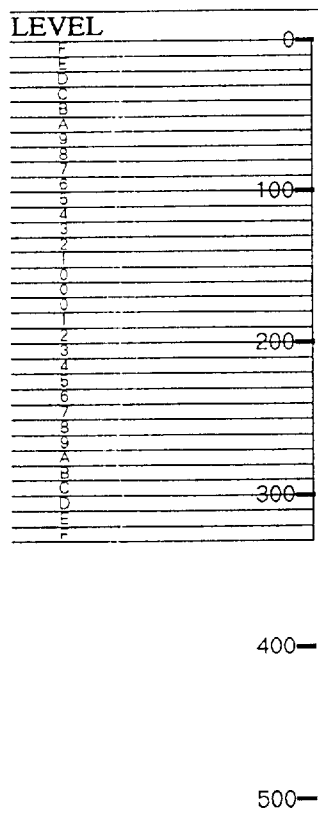

*Note 1: When the SLANT CALIB is set to ON on the menu display, the width of echoes on port, starboard and auto scan displays is reduced with the formula below.*

$$\text{Width (slant display)} = \text{Width (vertical display)} \times \cos(\text{TX angle})$$

*2: The above display is given when the CLUTTER control is set to 0.*

- 3: *The color bars do not appear when the **SCAN SPEED** is set to **HIGH** on the **TRANSMITTER** menu.*
- 4: *The **GAIN** and **TVG** controls do not function during this check.*
- 5: *The **UP/DN**, **DN** and **EXT** positions of the **SUB MODE** switch can be checked when a net recorder or external transceiver is connected.*

---

## 10. SPECIFICATIONS

---

### Display Unit CV-100

- |   |  |
|---|--|
| 1. Display Tube   | 14" diagonal medium resolution CRT   |
| 2. Echo Color   | 8 or 16 colors depending on echo intensity. (Combination of colors can be selected by the HUE key.)  |
| 3. Basic Display Range  | 100, 200, 500, 1000, 1500 m (Reprogramable by MENU.)   |
| 4. Display Start Depth  | 0 to 6000 m minus basic display range  |
| 5. Sounding Direction   | Slant port, slant starboard, vertical, auto scanning (slant port and slant starboard)  |
| 6. Presentation Mode  | 1) Vertical sounding<br>2) Slant port sounding<br>3) Slant starboard sounding<br>4) Autoscan sounding<br>5) Bottom-locked expansion<br>6) Pelagic expansion<br>7) A-scope presentation<br>8) Monitoring external net recorder (Upward and/or downward sounding)<br>9) Monitoring external transceivers (ETR-2B/3B) sounding signal |
| 7. Expansion Range  | 5, 10, 20, 40, 80 m for both pelagic expansion and bottom-locked expansions  |
| 8. Variable Range Markers (VRM)   | 1) Vertical VRM (Time or distance* from VRM to present position)<br><br>2) Horizontal VRM (Depth from zero line to VRM)  |
| <i>Note: Speed log input required to measure the distance from the vertical VRM to the present ship's position.</i> |  |
| 9. Display Memory Capacity  | One full screen  |
| 10. Brilliance Control  | Adjustable in four steps   |
| 11. Digital Display   | Ship's position in latitude and logitude, Water temperature (digital readout and graph), Ship's speed*   |

*\* Navigation equipment, water temperature indicator and speed log required.*

- |                           |   |
|---------------------------|---|
| 12. Power Supply          | 100/110/115 Vac, 2 A, 50/60 Hz, 1 $\phi$ ,<br>220/230 Vac, 1 A, 50/60 Hz, 1 $\phi$ (Optional step-down transformer CI-350 required) |
| 13. Dimensions and Weight | 372 (W) x 432 (H) x 465 (D) mm, 21 kg   |

#### **Transceiver Unit CV-101**

- |                             |   |
|-----------------------------|---|
| 1. Frequency                | 24 kHz  |
| 2. Output Power             | 10 kW <sub>rms</sub>  |
| 3. Pulselength              | 1 to 20 msec (variable according to display range)  |
| 4. Number of Transmission   | 200 ppm or less (variable according to display range)   |
| 5. Slant Sounding Direction | Can be set in 1 degree or 2 degrees step from 0 degrees (vertical) to 16 degrees or 36 degrees.   |
| 6. TVG Curve                | 20logR, 20log2R, 30logR, 40logR (selected on the menu display)  |
| 7. Detection Capability     | 6000 m for seabed, 1400 m for fish in a satisfactory condition  |
| 8. Power Supply             | 100/110/115 Vac, 2 A, 50/60 Hz, 1 $\phi$ or<br>220/230 Vac, 1 A, 50/60 Hz, 1 $\phi$ (Change of transformer tap connection is required.) |
| 9. Dimensions and Weight    | 374 (W) x 194 (H) x 592 (D) mm, 25 kg   |

#### **Transducer CV-102**

- |                          |  |
|--------------------------|--|
| 1. Beamwidth             | 10 degrees (port-starboard) x 9.5 degrees (fore-aft) at -3dB point |
| 2. Dimensions and Weight | 467 x 467 x 167 (H) mm, 65 kg                                      |

#### **Clinometer CV-103**

- |                          |   |
|--------------------------|---|
| 1. Detection Direction   | Ship's rolling of port 20 degrees to starboard 20 degrees |
| 2. Dimensions and Weight | 168 (W) x 108 (H) x 150 (D) mm, 2 kg                      |

## COMPLET SET

No.	Description	Type	Qty	Code Number	Remarks
1	Display Unit	CV-100-E	1	000-014-552 000-014-591	For color 2.5GY5/1.5 For color 2.5G7/2
2	Transceiver Unit	CV106-6	1	000-014-553	100/110/115 Vac
		CV-101-7	1	000-014-554	220/230 Vac
3	Transducer	CV-102	1	000-014-557	
4	Thru-hull Pipe	TFB-1400	1	000-015-227	
5	Clinometer	CV-103	1	000-014-558	
6	Spare Parts		1 set		See table on following page.
7	Installation Materials		1 set		See table on following page.
8	Accessories		1 set		See table on following page.

## OPTION

No.	Description	Type	Code Number	Remarks
1	Recorder Unit	FE-1280	1	Vertical feed or horizontal feed
2	Paper Winder	WI-31	000-014-589	
3	Step-down Transformer	CI-350-72	000-069-848	For 220 Vac ship's mains
		CI-350-73	000-069-849	For 230 Vac ship's mains
4	Transducer Tank	T-674	000-015-989	

### Accessories

No.	Description	Type	Qty	Sketch	Code Number	Remarks
1	Hood	10-044-0032-0	1	1	000-109-250	
2	Filter Assembly	FP02-02620	1	2	002-007-290	
3	Vinyl Cover	10-044-0031-1	1	3	000-801-859	

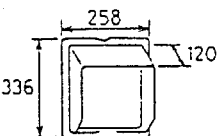
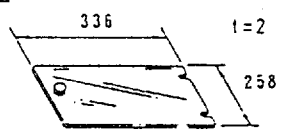
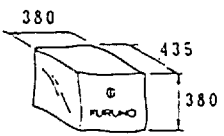

<p>1</p> 	<p>2</p> 	<p>3</p> 
--	--	---

### Installation Materials

No.	Description	Type	Qty	Sketch	Code Number	Remarks
1	Copper Strap	WEA-1004-0	1	1	500-310-040	For display unit
2	Connector	NCS-252-P	1	2	000-506-501	For display unit
3	Connector	SRCN6A13-3P	1	3	000-508-660	
4	Connector	SRCN6A16-10P	1	4	000-508-663	
5	Connector	SRCN6A25-24P	1	5	000-508-676	
6	Insulation Tube	3.0x0.3 *50cm*	4	6	000-568-226	
7	Copper Strap	WEA-1004-0	1	1	500-310-040	For transceiver unit
8	Connector	NCS-252-P	1	7	000-506-501	
9	Signal Cable Assy.	S02-13-10 (24-25P)	1	8	002-007-270	
10	Signal Cable Assy	S02-14-10 (5-3P)	1	8	002-007-270	For clinometer unit
11	Signal Cable Assy	S02-19-10 (24P)	1		002-135-270	For FE-1282

<p>1</p> 	<p>2</p> 	<p>3</p> 	<p>4</p> 
--	--	---	--

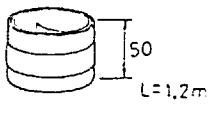
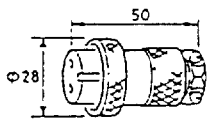
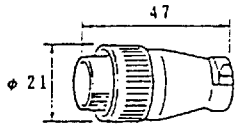
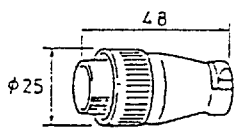
### Accessories

No.	Description	Type	Qty	Sketch	Code Number	Remarks
1	Hood	10-044-0032-0	1	1	000-109-250	
2	Filter Assembly	FP02-02620	1	2	002-007-290	
3	Vinyl Cover	10-044-0031-1	1	3	000-801-859	

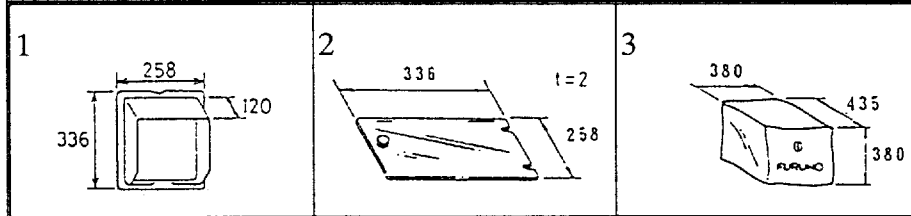

### Spare Parts

No.	Description	Type	Qty	Fig.	Code Number	Remarks
1	Fuse	FGBO 7A, AC125V or JSO 7A, 125A	1	1	000-549-013	For 100/110/115 Vac ship's mains
		FGBO 5A, AC125V	1	1	000-549-022	For 220/230Vac ship's mains
2	Fuse	FGBO 3A, AC125V or JSO 3A, 125A	1	1	000-549-063	
3	Hex Wrench	Hex size 4 mm	1	2	000-830-132	
4	Spare Parts Box	For F-710	1	3	000-831-610	

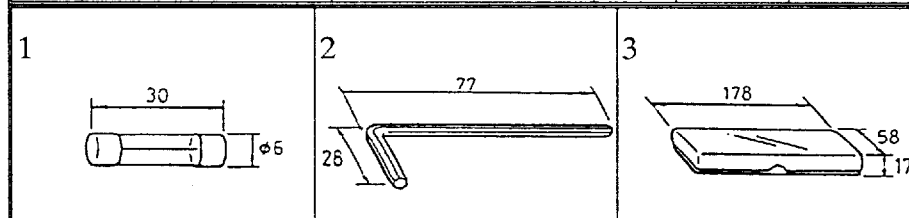



# 11. INSTALLATION

## Recommended Installation of Transducer CV-102

When the transducer CV-102 is installed on a large vessel just under the bulbous bow, we recommend that it be installed as shown in Fig. 1. FURUNO standard tank T-674 is not strong enough for big slamming.

- 1) For locally made tank, use a steel plate whose thickness is 10 to 12 mm.
- 2) The diameter of the cable hole in the top plate should be between 60 and 80 mm.
- 3) Fix the transducer cable as shown in Fig. 1 if the distance between the transducer and the thru-hull pipe is longer than 1 m. This will prevent damage to wiring inside the transducer due to cable vibration.

### Recommended installation:

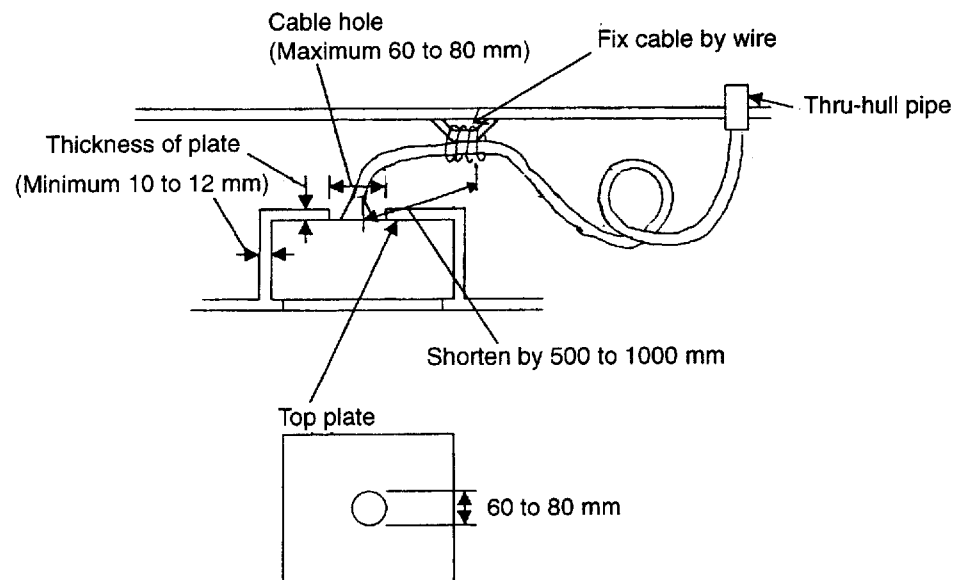

Fig.1

## CAUTION

Damage to the CV-102 has been reported from large trawlers where the transducers, installed just under the bulbous bow, have been struck by waves.

According to our investigation, the CV-102 was installed as shown in Fig. 2 or Fig. 3. These installations did not provide sufficient protection from large waves and thus the transducers were damaged.

Installation case 1 (Refer to Fig. 2): The cutout in the top plate was 400 mm in diameter. Because of the large cutout and large waves, the top of the CV-102 projected outward, which allowed waves to dent the transducer bottom and break wires and elements in the transducer.

Installation case 2 (Refer to Fig. 3): The transducer is only fixed by two bars instead of the top plate. This allowed the transducer to separate from the tank and break.

### Bad installation: Case 1

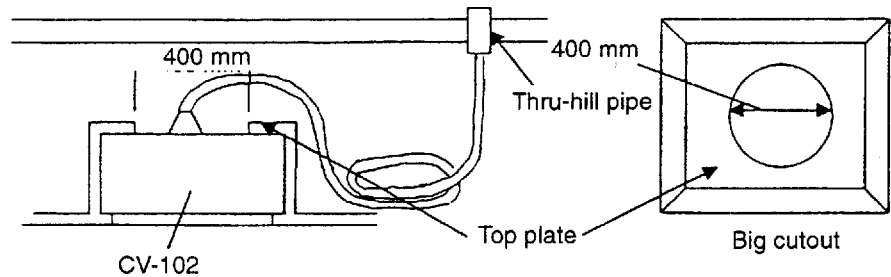

Fig. 2

### Bad installation: Case 2

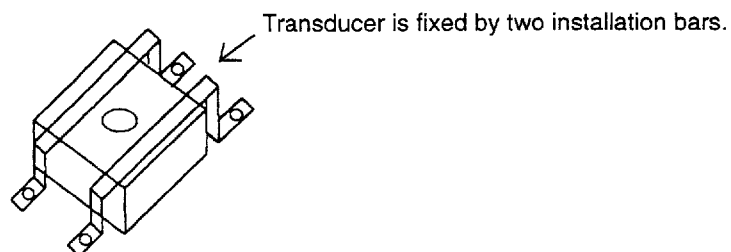
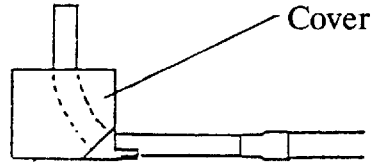

Fig. 3

## Assembling the Transducer Cable

The transducer cable is 30 meters long and has necessary contact pins attached. Insert contact pins into the connector plug and assemble the connector when the unit is installed on board the ship.

- 1) Pass the cable through the connector housing like the figure below.



- 2) Insert the contact pins to the plug until they are securely pushed in. Refer to the wiring list for each lead color.

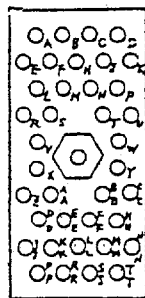
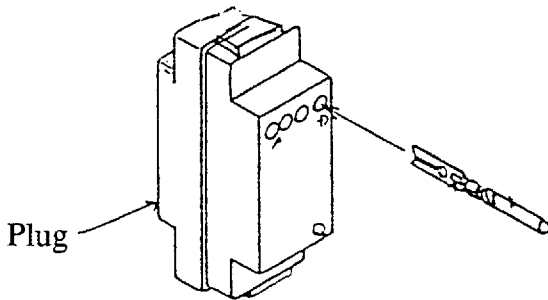

	Color		Color
A	White	EE	(White)
B	Red	FF	(Red)
C	Green	HH	(Green)
D	Yellow	JJ	(Yellow)
E	Brown	KK	(Brown)
F	Blue	LL	(Blue)
H	Gray	MM	(Gray)
J	Orange	NN	(White/Yellow)
K	Purple	PP	Black
L	White/Black	RR	(White/Black)
M	White/Red	SS	(White/Red)
N	White/Green	TT	(White/Green)

*Note: Colors in parentheses denote colors of tubing which covers black color vinyl leads.*

Note: Colors in parentheses denote colors of tubing which covers black color vinyl leads.

3) Fix the plug and cable clamp to the connector cover.

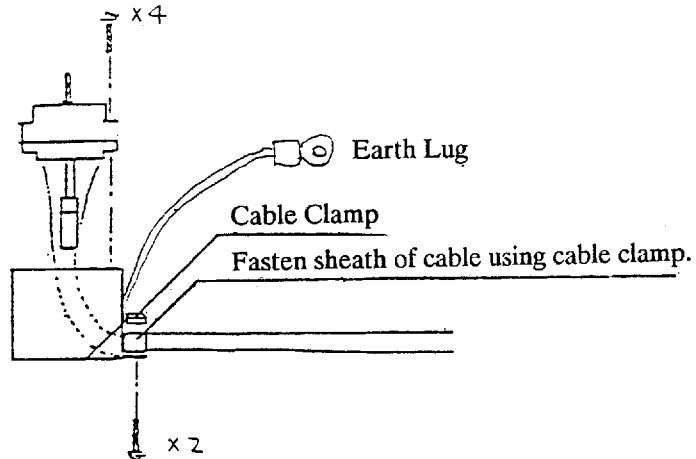

4) Check that the guide pin is set to 1 (factory setting is also 1).

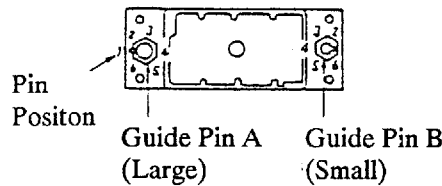
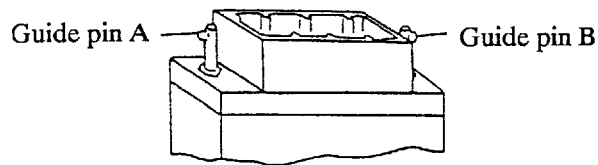

## Modifying Unit for Connection with FE-1280

Modify the display unit as follows to connect the FE-1280 (option).

- 1) Remove wires which connect J2 on rear panel to SUB board. Then, make wiring between J2 on rear panel and SUB board by using "SRC Connector 1" (connectors fitted with interconnection wires) supplied as an installation material of FE-1280.
- 2) Make wiring between J3 on rear panel and SUB board by using "SRC Connector 2" supplied as an installation materials of FE-1280.

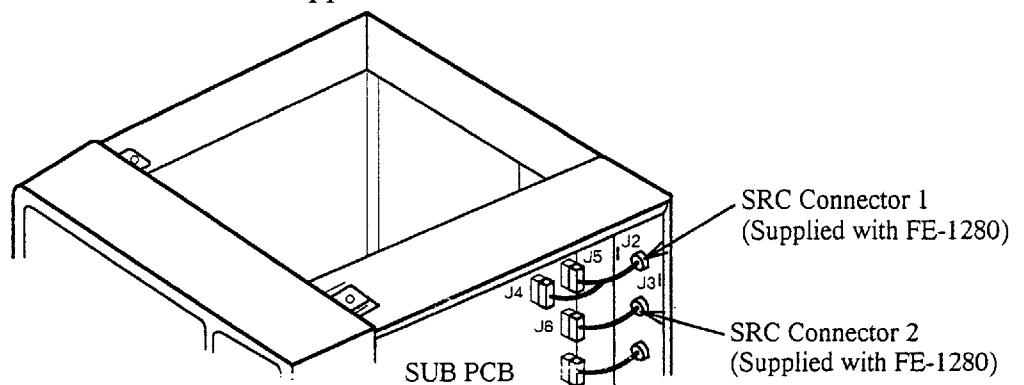

## Installing Clinometer Unit

The clinometer is used to detect the inclination of the ship during rolling to stabilize the transmitting beam. Therefore it is preferable that it be located as near the ship's rolling axis as possible. The best position is summarized as below:

- 1) The vertical position is as close to the ship's draft level as possible.
- 2) The horizontal position is as close to the ship's center as possible.

Following the recommendations outlined in 1) and 2), the mounting position is shown below.

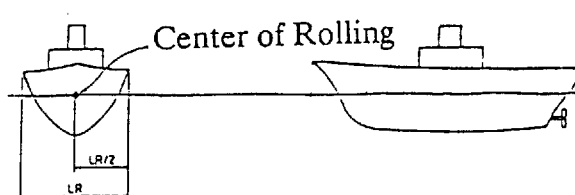

*Note: The unit should be oriented forward referring to the bow mark.*

### Calibration of Clinometer

If the clinometer causes unwanted error due to its mounting position, compensate for it on the **INITIAL** menu.

- 1) Measure actual inclination by the ship's clinometer.
- 2) Press the **MENU** key to present the menu display.
- 3) Three digital displays shows rolling angle in three digit.
- 4) Select the calibration value at the **ROLL-AMP ADJUST** between -10% and +10% so that the digital display indicates the value most closest to the actual inclination angle.

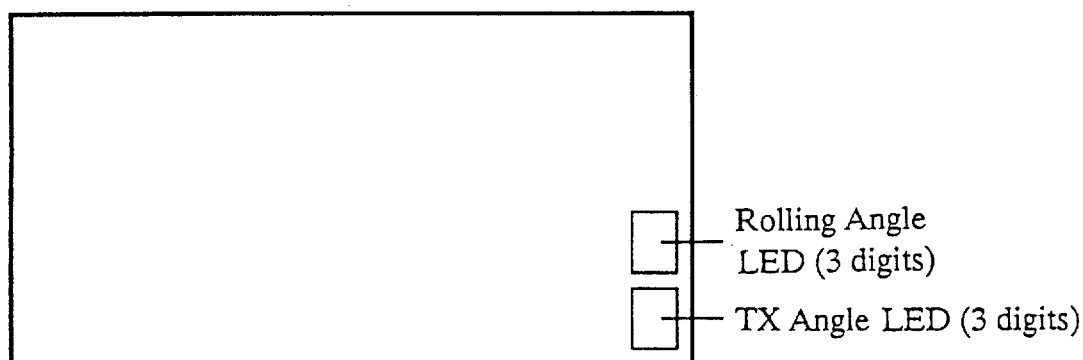

# Index

## A

A-scope presentation ..... 5, 13  
ADVANCE selector ..... 5, 8, 29  
AUTO scan display ..... 6, 12, 20

## B

Beamwidth ..... 25  
BL/DN key ..... 5, 14  
Bottom-lock Range ..... 5, 14  
Bottom shape ..... 21  
BRILLiance key ..... 5, 7

## C

Character (Display) ..... 26  
CIF Format ..... 23  
CLUTTER control ..... 5, 10, 29  
Control panel ..... 5

## D

Degauss button ..... 4  
Demo display ..... 33  
Depth ..... 18  
    Scale ..... 26  
Display advance speed ..... 5, 8  
Display range ..... 7  
Display start depth ..... 5  
Distribution of fish ..... 21

## E

ENT/A key ..... 5, 16, 22  
EXP/UP key ..... 5, 13  
External echo sounder display ..... 6  
    EXT SElector ..... 26  
External marker ..... 26  
External keying pulse ..... 25

## F

False echo ..... 21  
Fish distribution ..... 21

## G

GAIN control ..... 5, 9, 29

## H

Horizontal VRM ..... 15  
HUE Key ..... 5, 7, 27

## I

Inteference rejector (ES IR, NET IR) ..... 25

## L

LESD display ..... 31  
LOG input ..... 23  
LOG position  
    Picture freeze ..... 9

## M

Menu ..... 5, 22  
    Beamwidth ..... 25  
    Character ..... 26  
    Depth range ..... 27  
    Depth scale ..... 26  
    Depth unit ..... 23  
    Display menu ..... 26  
    Expansion marker ..... 26  
    External KP ..... 25  
    External selector ..... 26  
    I/O Format ..... 23  
    Legend ..... 26  
    MENU key ..... 5, 22  
    NAV INPUT ..... 23  
    POSITION DATA ..... 23  
    SCAN speed ..... 24  
    SCANning STEP ..... 24  
    SIDELOBE ..... 24  
    Slant calibration ..... 26  
    Speed LOG INPUT ..... 23  
    Split screen ..... 26  
    TVG Curve ..... 25  
    TVG Range ..... 25  
    TX OUTPUT ..... 24  
    TX PRR ..... 24  
Minute Marker ..... 18  
MODE selector ..... 5, 7, 11

## N

Navigator input ..... 23  
Net Recorder ..... 5, 6, 14

Interference rejector (NET IR) .....	25
NMEA format .....	23

## O

OFF key .....	5, 7
---------------	------

## P

Pelagic expansion display .....	13
Pelagic expansion range .....	5
Port display .....	6
Position data .....	23
Power (PWR) Key	
PWR key .....	5, 7

## R

RANGE selector .....	5, 7
RECALL key .....	5, 16
Recalling display .....	5
Recalling the stored display .....	15
Roll calibration .....	24

## S

Scanning area .....	19
Scan speed .....	24
Scan step .....	24
Self-check .....	30
Shape of bottom .....	21
SHIFT key .....	8
Ship's position .....	18
Ship's speed .....	18
Sidelobe .....	21, 24
Split screen .....	26
Sounding angle .....	5
STBD (Starboard) display .....	6
STORE key .....	5, 15
Storing display .....	5, 15
Sub mode	
Expansion .....	12
External echo sounder .....	12
NET DN key .....	12
NET UP/DN key .....	12
SUB MODE Selector .....	5, 13
System diagnosis .....	30

## T

Time .....	18
Transducer cable .....	46
TVG control .....	5, 10
TVG curve .....	25

TVG level .....	6
TVG range .....	25
TX ANGLE key .....	13
TX DIRection selector .....	5, 7, 12
TX output .....	24
TX PRR (pulse repetition rate) .....	24

## U

Unit .....	23
------------	----

## V

Vertical display .....	6
Vertical VRM .....	15
VRM key .....	5, 14

## W

Water temperature	
graph .....	19
readout .....	19
temperature scale .....	19

## Z

Zero line .....	29
-----------------	----

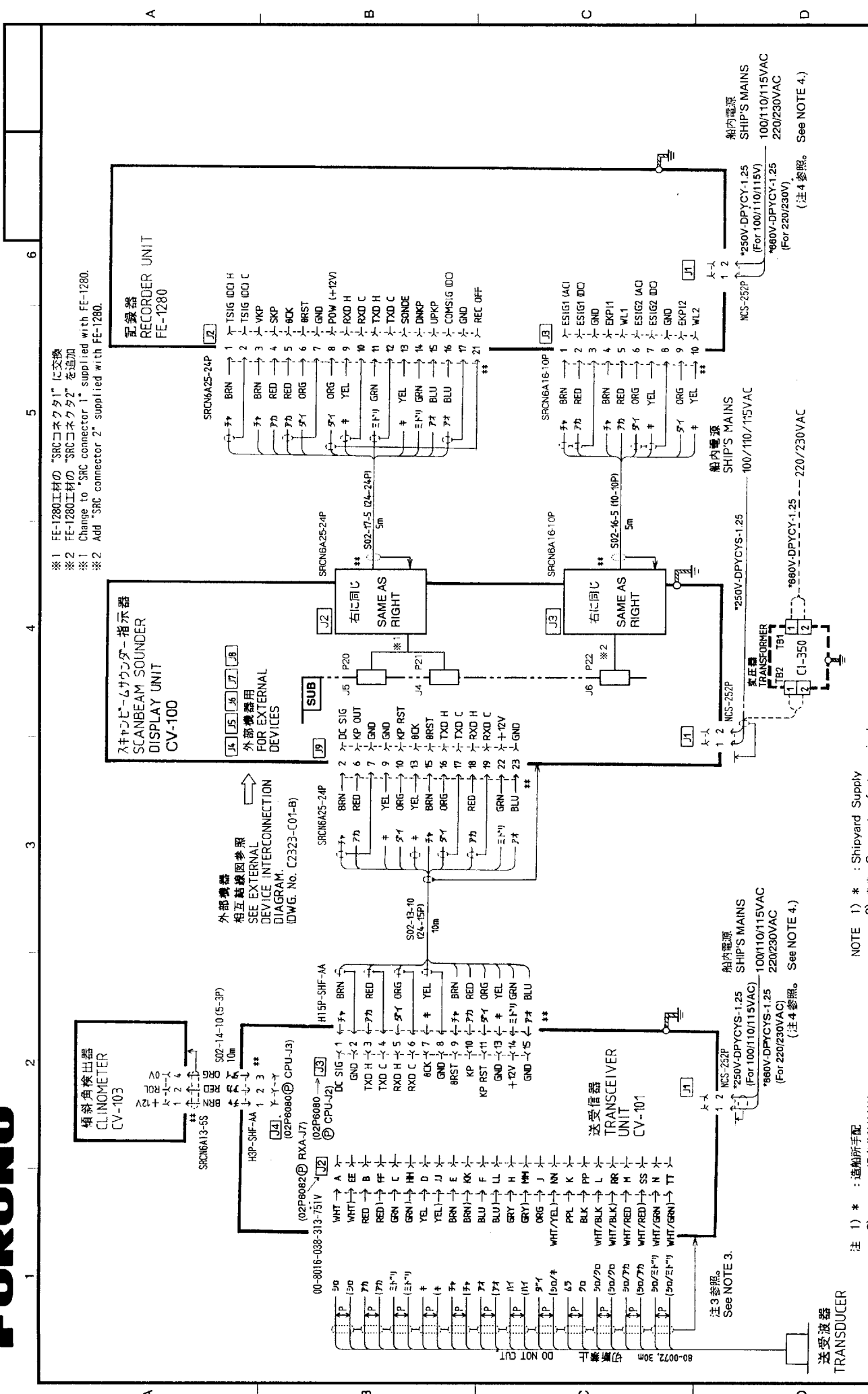

※1 FE-1280工材の“SRCコネクタ1”に交換  
 ※2 FE-1280工材の“SRCコネクタ2”を追加  
 ※3 Change to “SRC connector 1” supplied with FE-1280.  
 ※4 Add “SRC connector 2” supplied with FE-1280.

外部機器  
 相互接続図参照  
 SEE EXTERNAL  
 DEVICE INTERCONNECTION  
 DIAGRAM.  
 DWG. No. C2323-C01-B)

注 1) \* : 通動所手配  
 2) \*\* : 工場出荷時接続  
 3) 送受波器ケーブルの( )はリード線に被せた  
 スミチューブの色を示す。  
 4) 電源電圧をAC100/110/115VまたはAC220/230Vへ  
 変更する場合は、電源トランスのタップ変更  
 (送受信器)、電源パックの交換(記録器)および  
 ヒューズの交換(両ユニット)が必要です。

NOTE 1) \* : Shipyard Supply  
 2) \*\* : Connector factory-wired  
 3) Colors in ( ) for the transducer cable are of tubes  
 covering lead wires.  
 4) To change operating voltage between 100/110/115VAC  
 and 220/230VAC, change tap connection on power  
 transformer (transceiver unit), replace power pack  
 (recorder unit) and replace fuses (both units).

承認 APPROVED	MAY・28・90 T. NAKAWO	名称 TITLE	FCV-10 + FE-1280 相互接続図 INTERCONNECTION DIAGRAM
検図 CHECKED	APR・19・90 M. USUDA		
製図 DRAWN	APR・19・90 T. KODA	図番 DWG.NO	C2323-C02-D



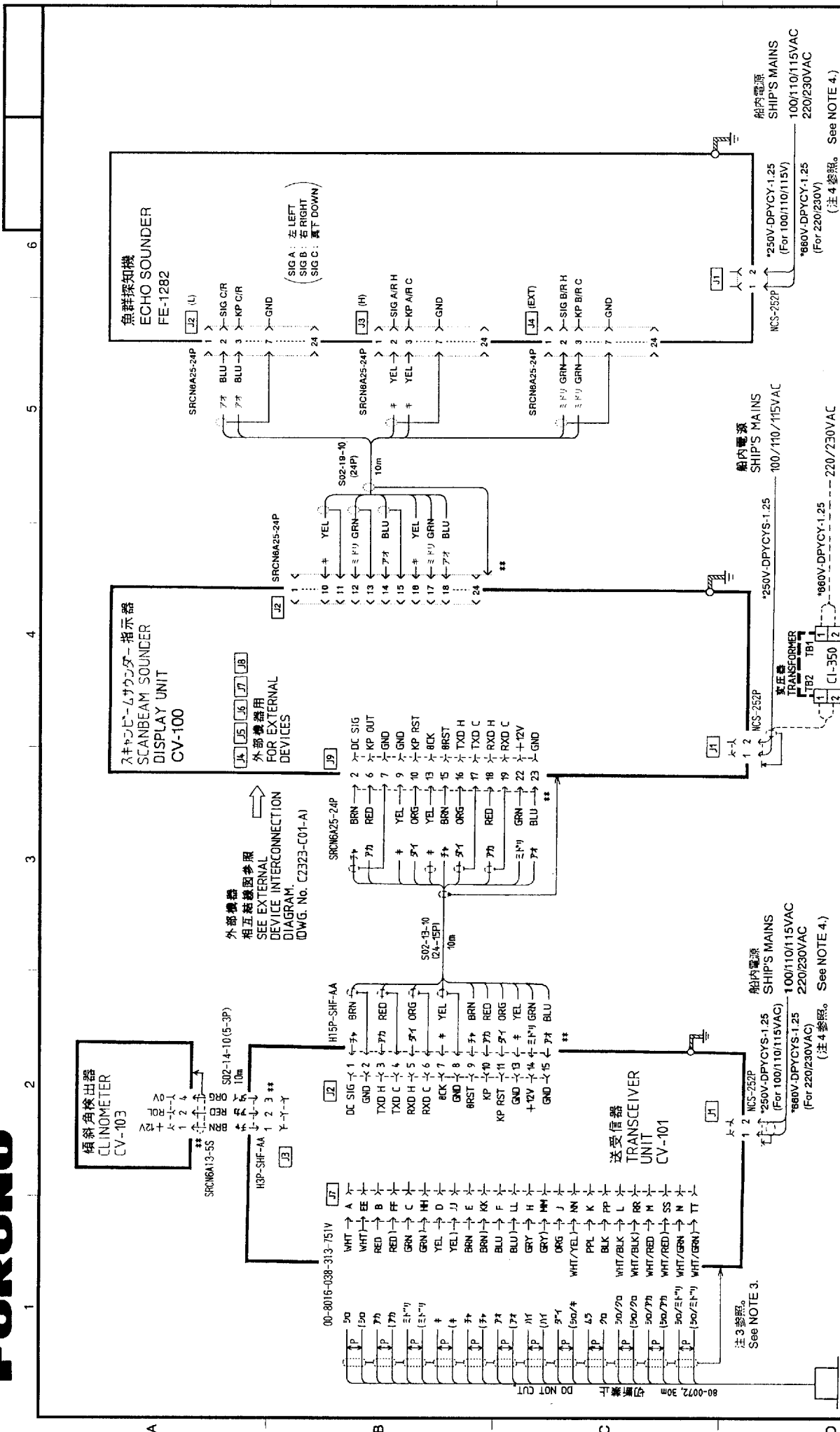

承認 APPROVED	FCV-10 + FE-1282	名称 TITLE	相互結線図
検図 CHECKED	FEB・19・93 K. OKAMOTO	製造 DRAWN	FEB・19・93 M. USUDA
製図 DRAWN	FEB・19・93 M. USUDA	図番 DWG. NO	C2323-C03-B

注 1) \* : 造船所配  
 2) \*\* : 工場出荷時接続済  
 3) 送受波器ケーブルの ( ) はリード線に被せた  
 スミューブの色を示す。  
 4) 電源電圧をAC100/110/115VまたはAC220/230Vへ  
 変更する場合は、電源トランスのタップ変更  
 (送受波器)、電源パックの交換 (魚群探知機)  
 およびヒューズの交換 (両ユニット) が必要です。

NOTE 1) \* : Shipyard Supply  
 2) \*\* : Connector factory-wired  
 3) Colors in ( ) for the transducer cable are of tubes  
 covering lead wires.  
 4) To change operating voltage between 100/110/115VAC  
 and 220/230VAC, change tap connection on power  
 transformer (transceiver unit), replace power pack  
 (Echo Sounder) and replace fuses (both units).

送受波器  
TRANSDUCER



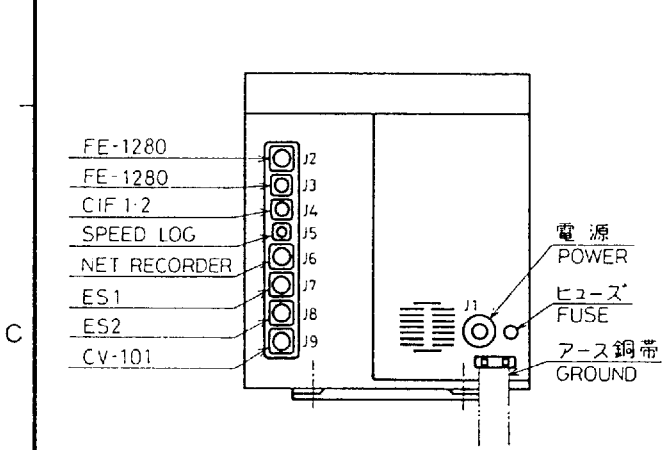
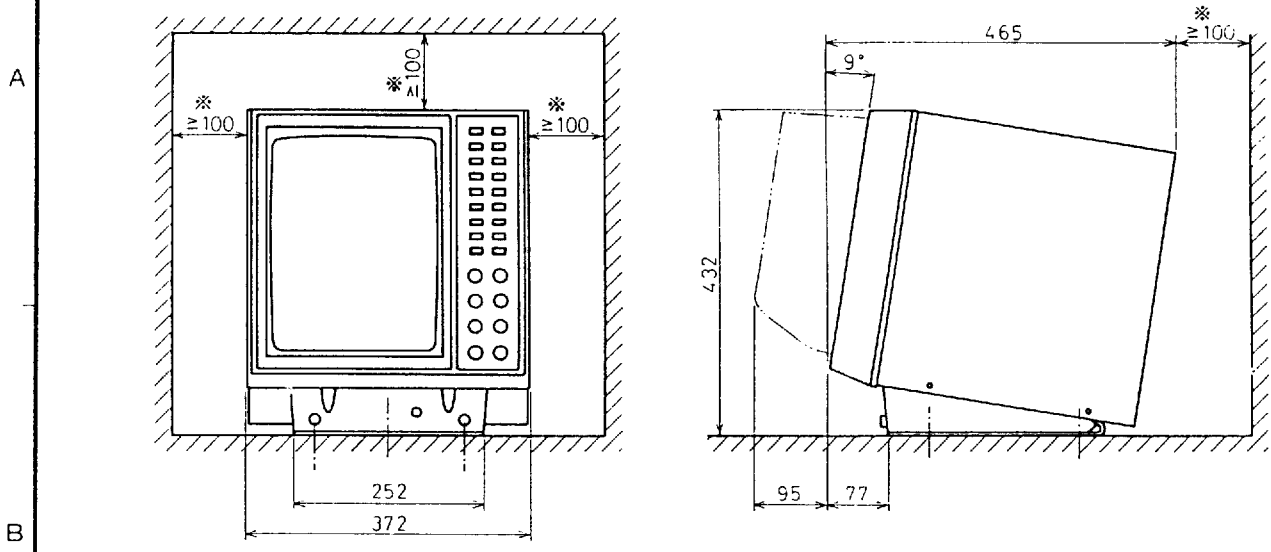

背面図  
REAR VIEW

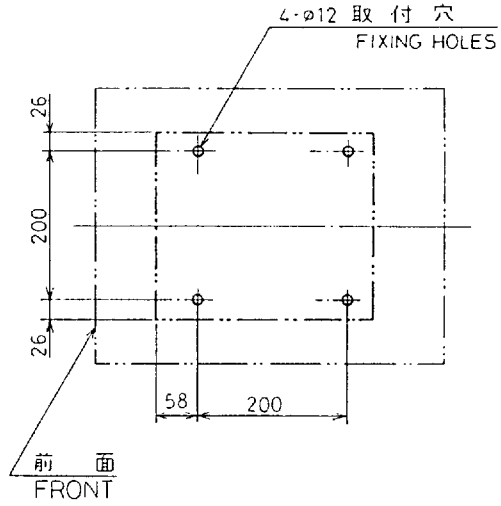

取付寸法  
MOUNTING DIMENSION

NOTE 1. 保守点検及び放熱用として \*印のスペースをとる事。  
DIMENSIONS MARKED "\*" SHOW MINIMUM MAINTENANCE AND VENTILATION SPACE.

品番 ITEM	品名 NAME	材質 MATERIAL	数量 Q'TY	図番 DWG. NO.	摘要 REMARKS
承認 APPROVED	JAW. 29. '90 T. NAKAHO	三角法 THIRD ANGLE PROJECTION	名称 TITLE	指示器 DISPLAY UNIT	
検図 CHECKED	JAN. 29. '90 M. USUDA	尺度 SCALE	1 / 10	FCV-10	
製図 DRAWN	Jan. 29. '90 T. KODA	重量 WEIGHT	21 kg	図番 DWG. NO.	C2323-G01-A

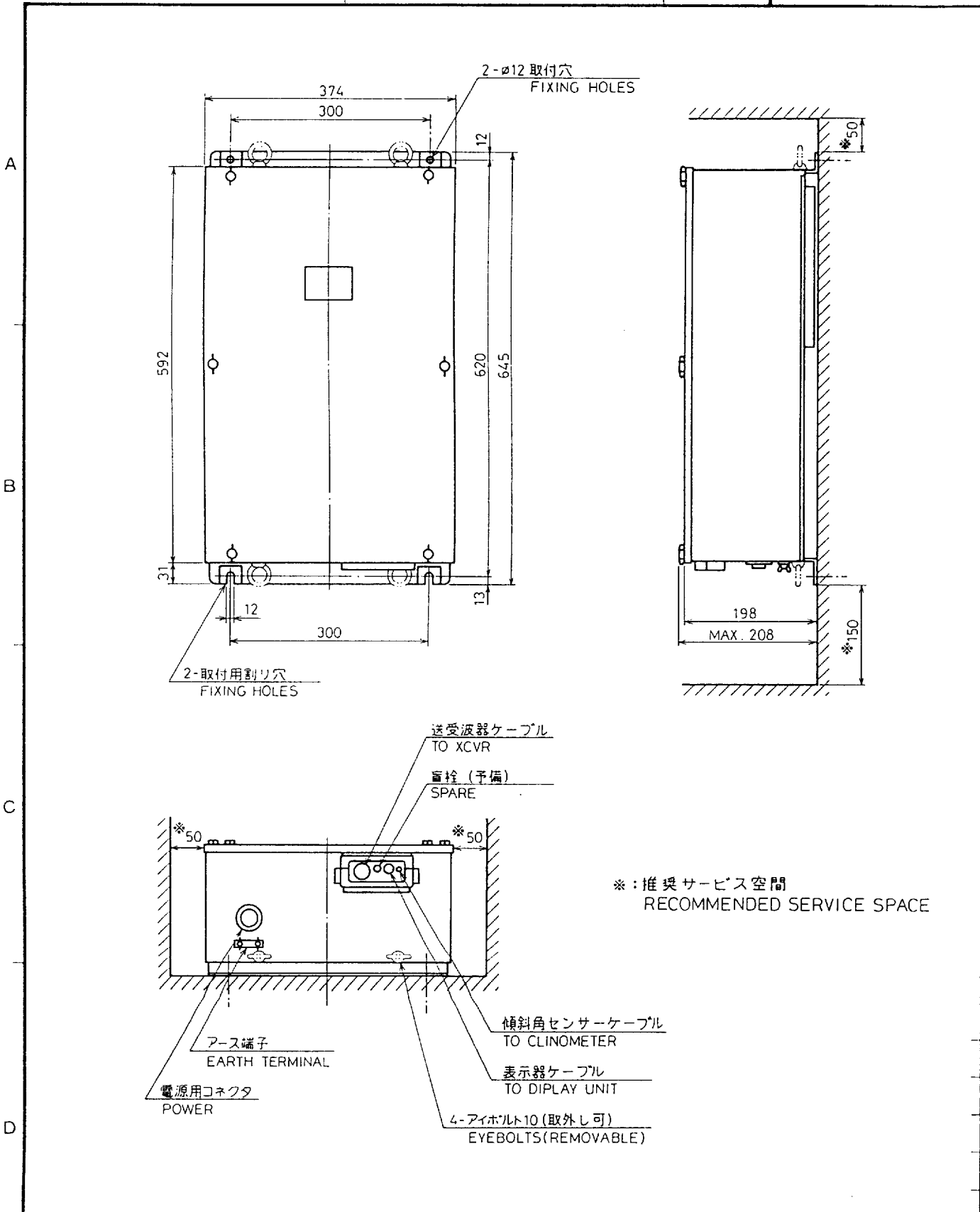

品番 ITEM	品名 NAME	材質 MATERIAL	数量 Q'TY	図番 DWG.NO.	摘要 REMARKS
承認 APPROVED	JAN. 22. '90 T. NAKAJO	三角法 THIRD ANGLE PROJECTION	名称 TITLE	送受信器 TRANSCIVER UNIT	
検図 CHECKED	JAN. 22. '90 M. USUDA	尺度 SCALE	1/8	CV-101	
製図 DRAWN	Jan. 22. '90 T. KODRA	重量 WEIGHT	25 kg	図番 DWG.NO.	C2323-G02-A

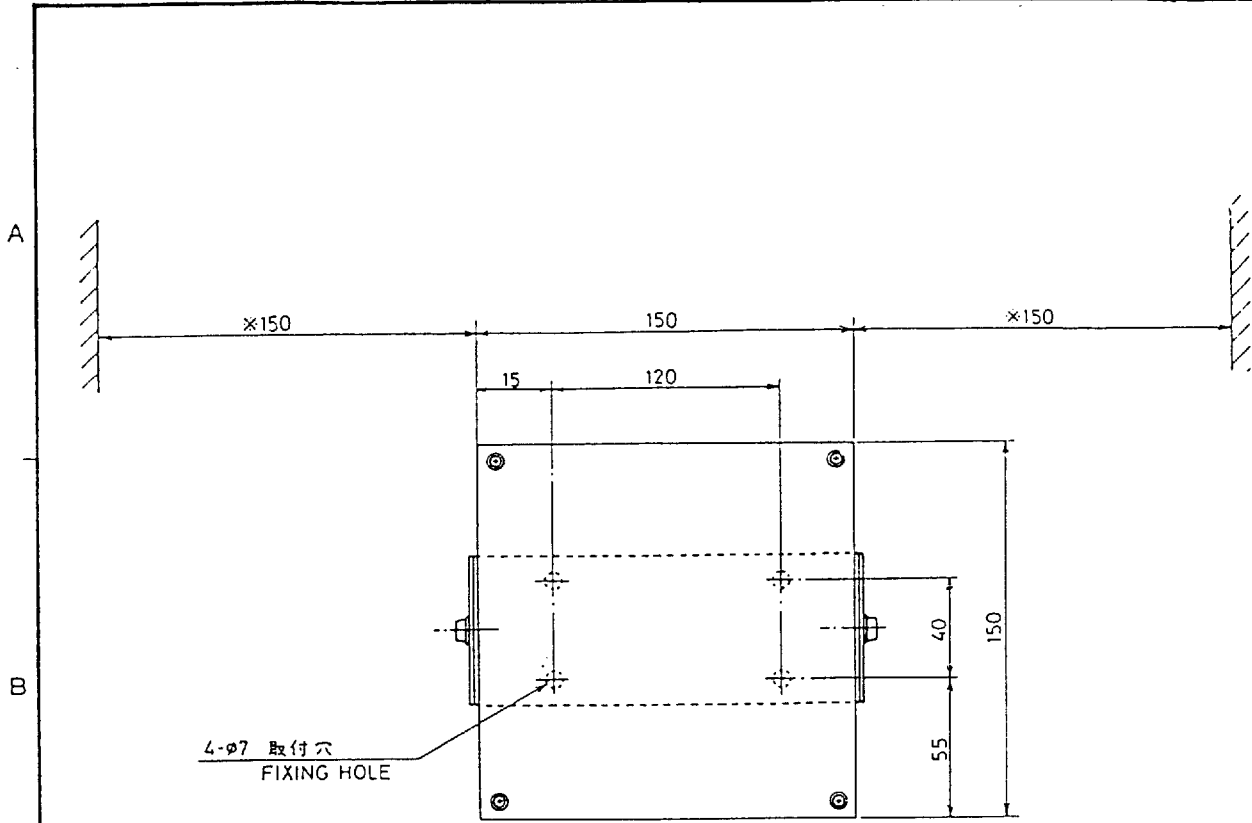

4-φ7 取付穴  
FIXING HOLE

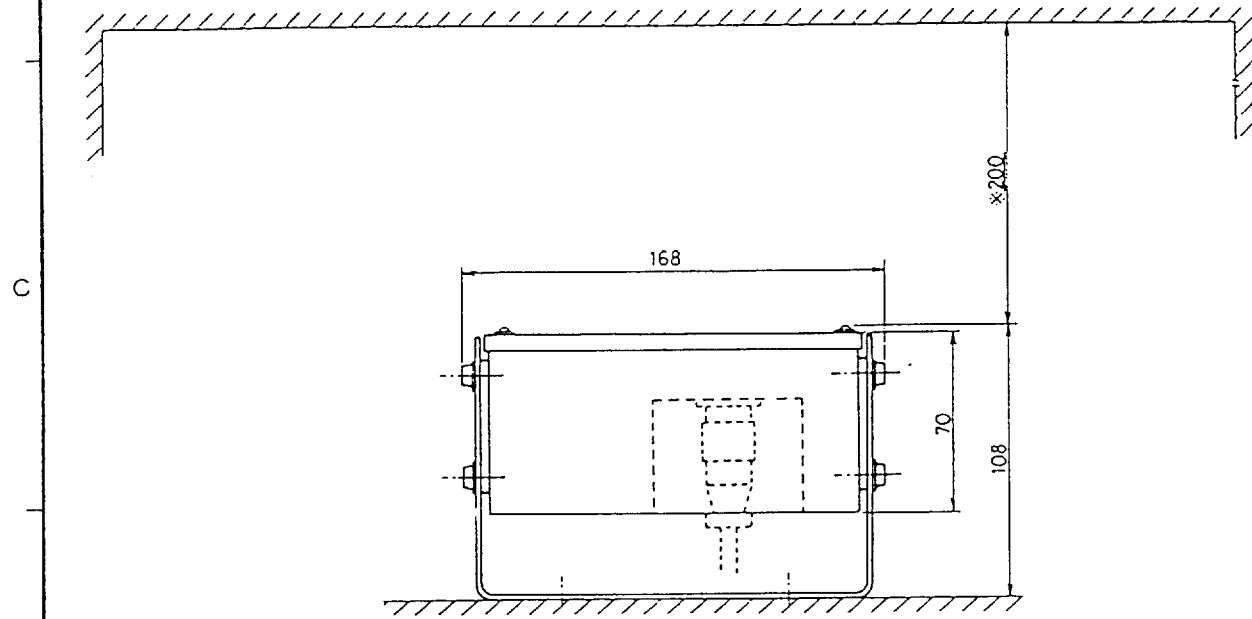

NOTE 1. 保守点検及び放熱用として \*印のスペースをとる事。  
DIMENSIONS MARKED \* SHOW RECOMMENDED MAINTENANCE AND VENTILATION SPACE.

品番 ITEM	品名 NAME	材質 MATERIAL	数量 Q'TY	図番 DWG NO.	備考 REMARKS
承認 APPROVED	三角法 THIRD ANGLE PROJECTION	名称 TITLE	傾斜角検出器 CV-103 CLINOMETER		
検図 CHECKED	尺度 SCALE	1/3			
製図 DRAWN	重量 WEIGHT	2 kg	図番 DWG. NO.	C1259-G01-A	

A

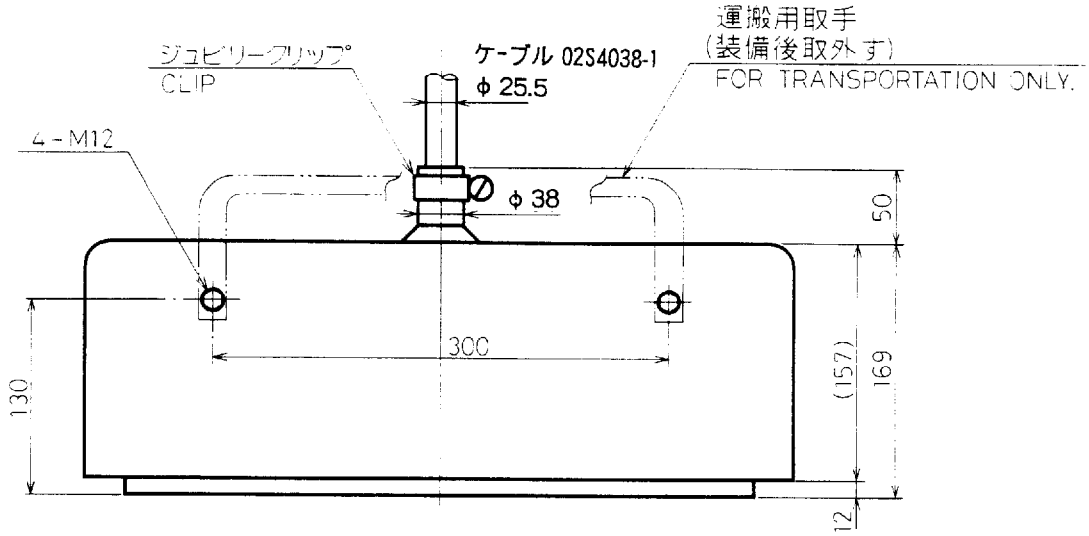

B

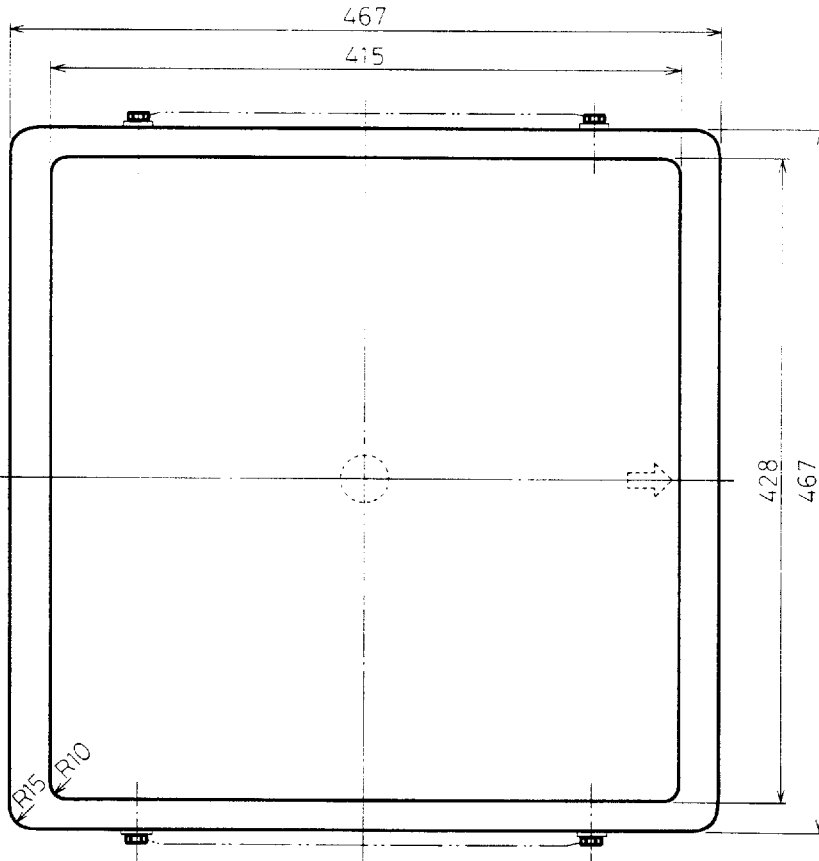

C

D

品番 ITEM	品名 NAME	材質 MATERIAL	数量 Q'TY	図番 DWG.NO.	摘要 REMARKS
承認 APPROVED	JAN.22.'90 T.NAKANO	三角法 THIRD ANGLE PROJECTION	名称 TITLE	送受波器外觀図 CV-102	TRANSUDER OUTLINE DRAWING
検図 CHECKED	JAN.22.'90 M.USUDA	尺度 SCALE	1/5		
製図 DRAWN	Jan.16.'90 T.KODAI	重量 WEIGHT	65 kg	図番 DWG.NO.	C2323-G03-B

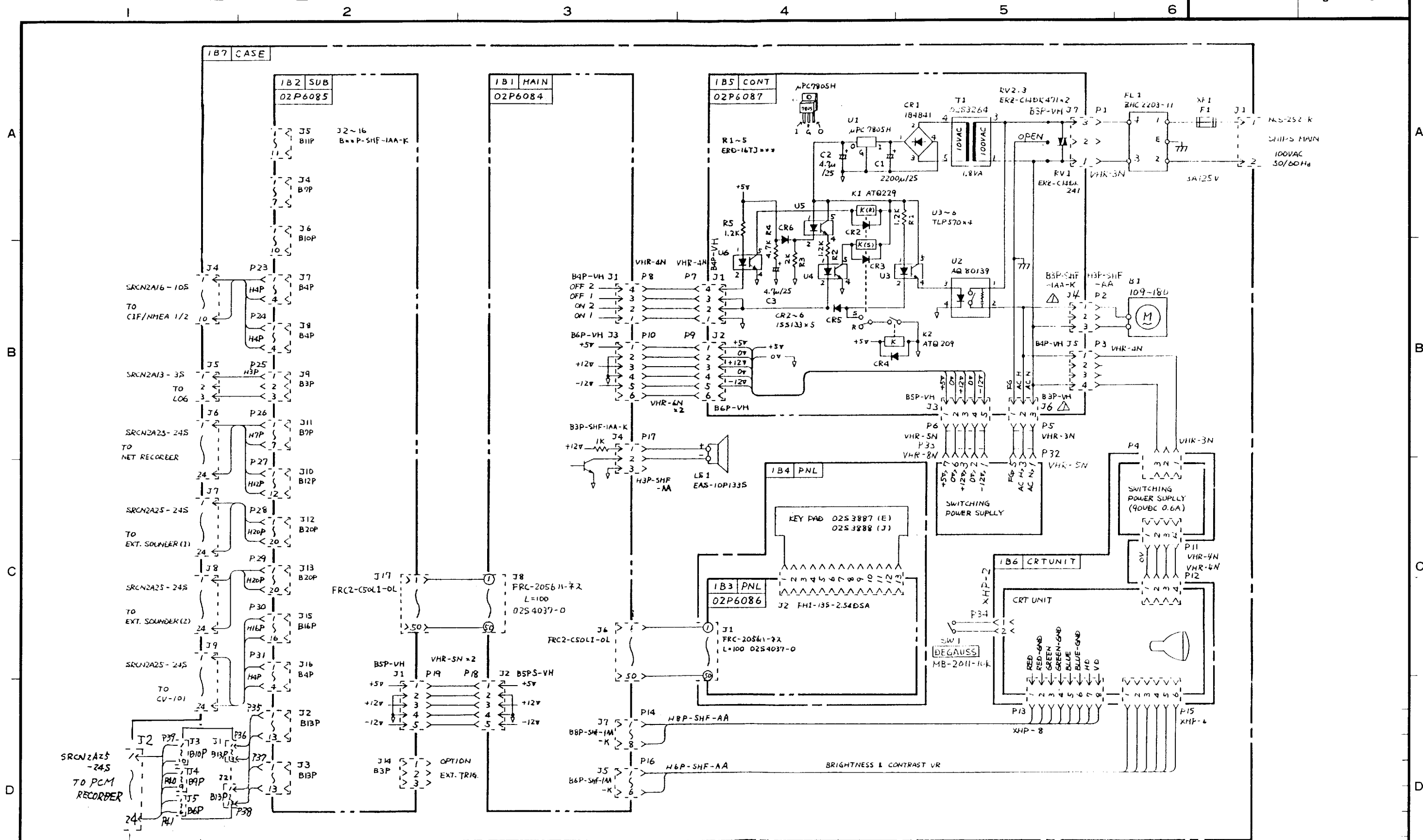

承認 APPROVED	MAY 28 1970 T. KODA	名称 TITLE	指示器 CV-100 DISPLAY UNIT
検査 CHECKED	MAY 28 1970 M. ISHIDA	製 DRAWN	図番 DWG. NO. C2323-K01-B

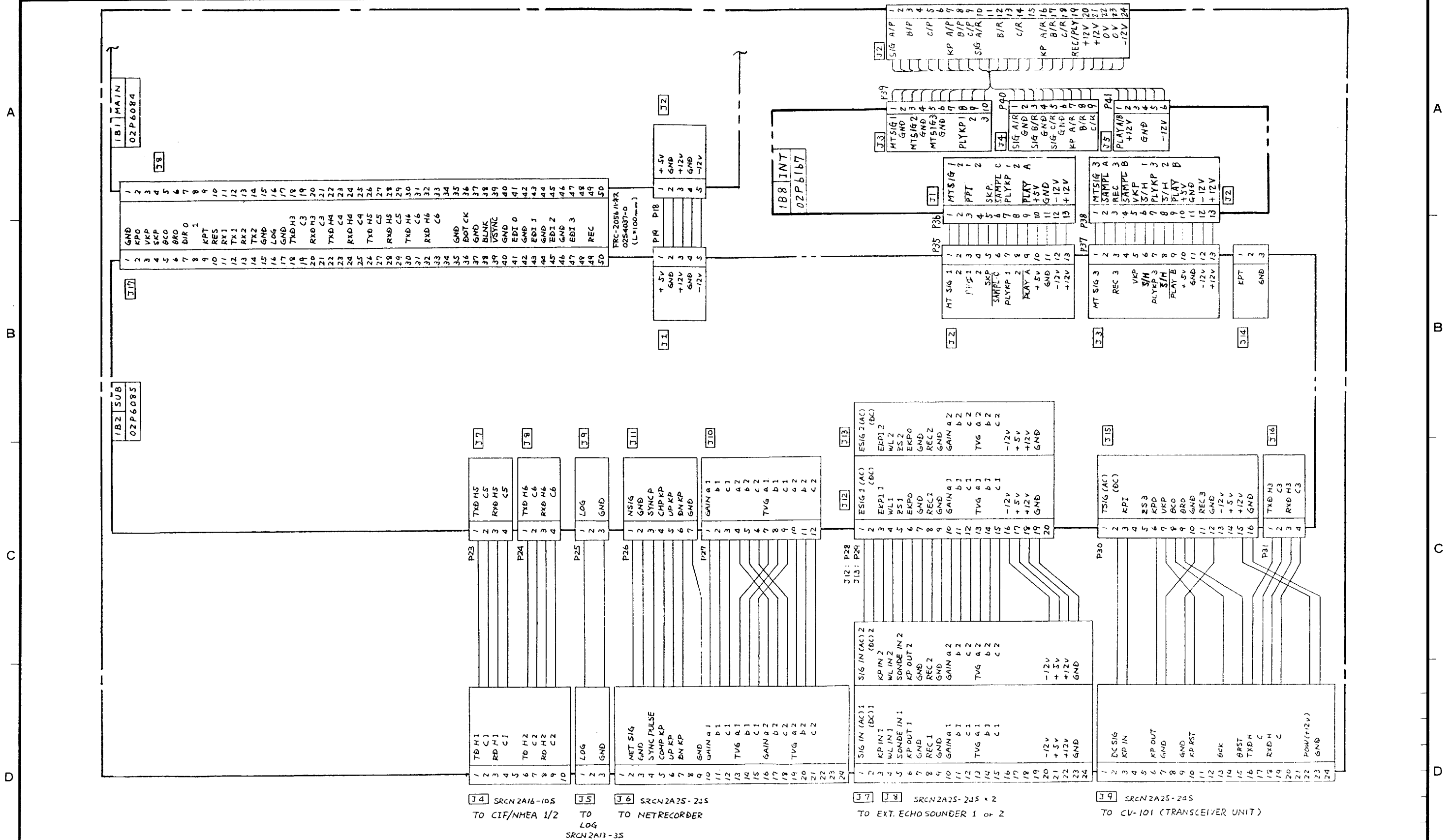



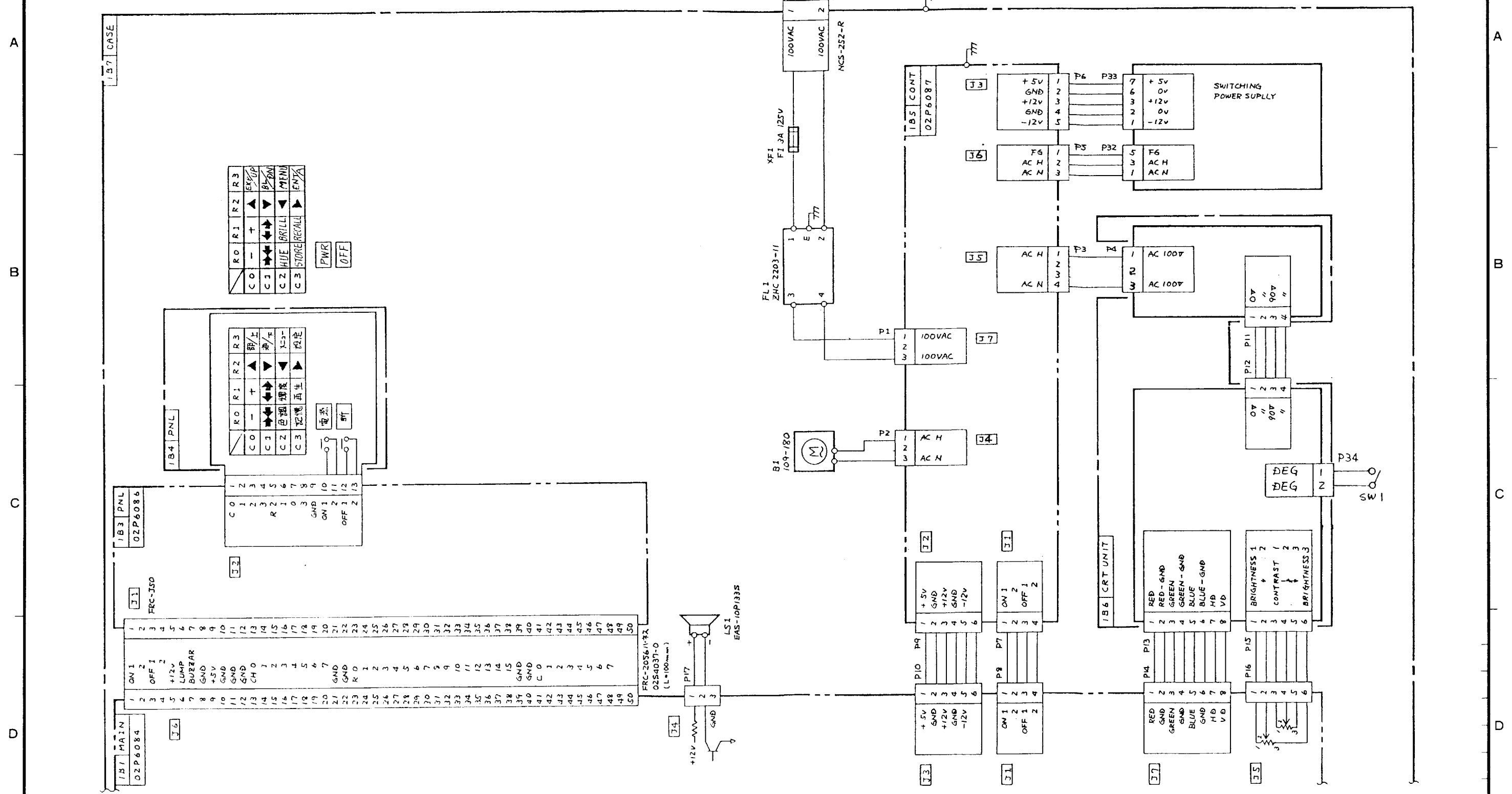

承認 APPROVED	MAY 28 1990 T. KAKAJO	名称 TITLE	CV-100
検 CHECKED	MAY 28 1990 H. HISHIYAMA	コネクタ接続図 CONNECTOR CONNECTION	(2/2)
製 DRAWN	MAY 28 1990 T. KAKAJO	図番 DWG. NO.	C2323-K03-B

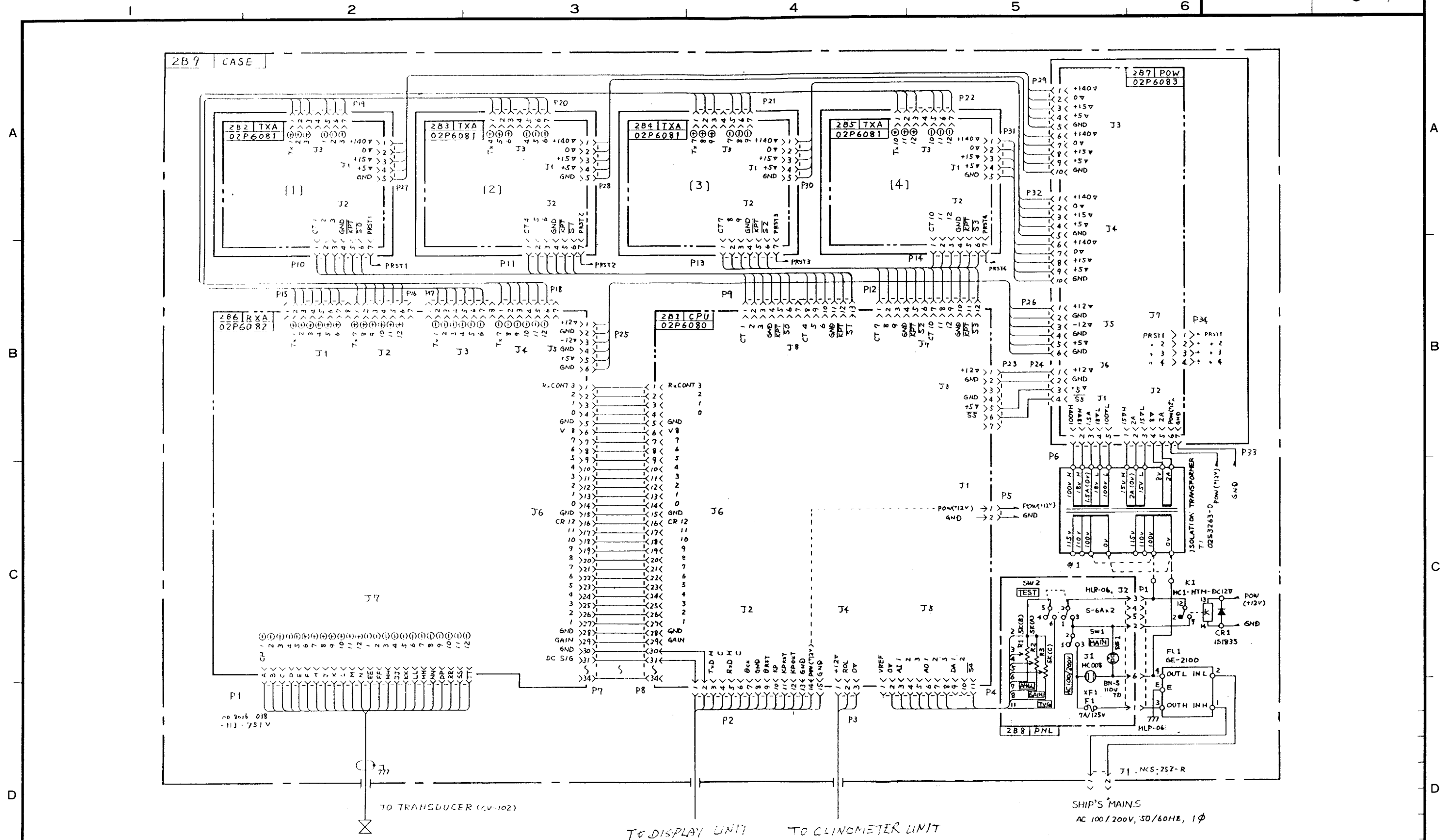

承認 APPROVED	MAY. 28. '90 T. WAKAYO	名称 TITLE	CV-101 送受信器 TRANSCEIVER UNIT
検査 CHECKED	MAY. 28. '90 H. USUDA	図番 DWG. NO.	C2323-K06-B
製 DRAWN	MAY. 28. '90 T. KODA		

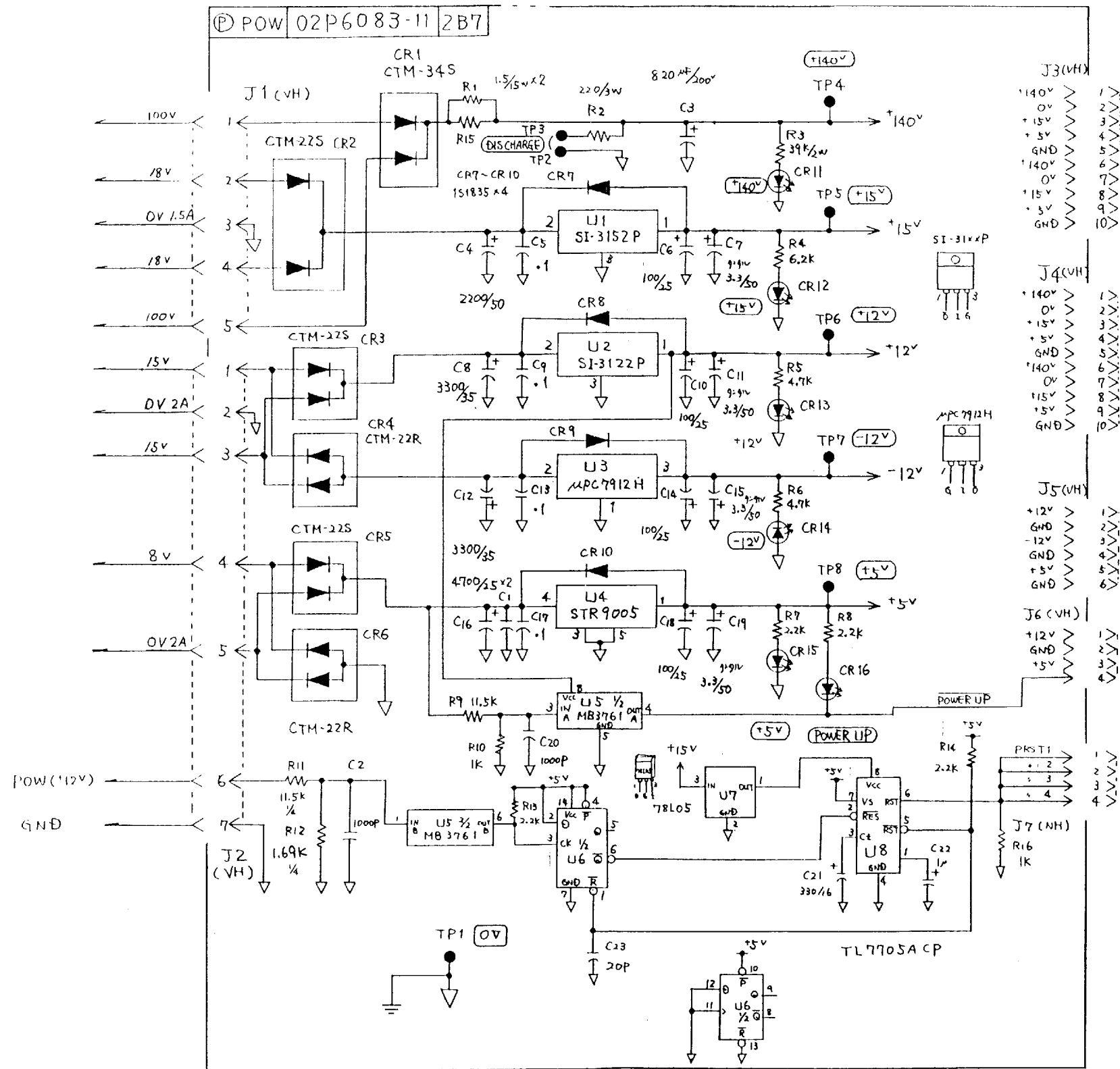

承認 APPROVED	MAY.28.90 T. UAKANO	名称 TITLE	02P6083-11 POW 基板 BOARD
検図 CHECKED	MAY.28.90 H. HSHIWA	図番 DWG. NO.	C2323-K12-A
製図 DRAWN	MAY.28.90 T. KOBAYASHI		