



# StorageTek™

## L40

Tape Library

**Installation Manual**

96053  
Revision: L





# L40 Tape Library

Installation Manual

Copyright 2006 Sun Microsystems, Inc., 4150 Network Circle, Santa Clara, California 95054, U.S.A. All rights reserved.

Sun Microsystems, Inc. has intellectual property rights relating to technology that is described in this document. In particular, and without limitation, these intellectual property rights may include one or more of the U.S. patents listed at <http://www.sun.com/patents> and one or more additional patents or pending patent applications in the U.S. and in other countries.

This document and the product to which it pertains are distributed under licenses restricting their use, copying, distribution, and decompilation. No part of the product or of this document may be reproduced in any form by any means without prior written authorization of Sun and its licensors, if any.

Third-party software, including font technology, is copyrighted and licensed from Sun suppliers.

Parts of the product may be derived from Berkeley BSD systems, licensed from the University of California. UNIX is a registered trademark in the U.S. and in other countries, exclusively licensed through X/Open Company, Ltd.

Sun, Sun Microsystems, the Sun logo, Java, AnswerBook2, docs.sun.com, and Solaris, StorageTek, VolSafe, TimberWolf, TimberLine, and RedWood are trademarks or registered trademarks of Sun Microsystems, Inc. in the U.S. and in other countries.

All SPARC trademarks are used under license and are trademarks or registered trademarks of SPARC International, Inc. in the U.S. and in other countries. Products bearing SPARC trademarks are based upon an architecture developed by Sun Microsystems, Inc.

The OPEN LOOK and Sun™ Graphical User Interface was developed by Sun Microsystems, Inc. for its users and licensees. Sun acknowledges the pioneering efforts of Xerox in researching and developing the concept of visual or graphical user interfaces for the computer industry. Sun holds a non-exclusive license from Xerox to the Xerox Graphical User Interface, which license also covers Sun's licensees who implement OPEN LOOK GUIs and otherwise comply with Sun's written license agreements.

U.S. Government Rights—Commercial use. Government users are subject to the Sun Microsystems, Inc. standard license agreement and applicable provisions of the FAR and its supplements.

DOCUMENTATION IS PROVIDED "AS IS" AND ALL EXPRESS OR IMPLIED CONDITIONS, REPRESENTATIONS AND WARRANTIES, INCLUDING ANY IMPLIED WARRANTY OF MERCHANTABILITY, FITNESS FOR A PARTICULAR PURPOSE OR NON-INFRINGEMENT, ARE DISCLAIMED, EXCEPT TO THE EXTENT THAT SUCH DISCLAIMERS ARE HELD TO BE LEGALLY INVALID.

Copyright 2006 Sun Microsystems, Inc., 4150 Network Circle, Santa Clara, California 95054, Etats-Unis. Tous droits réservés.

Sun Microsystems, Inc. a les droits de propriété intellectuels relatants à la technologie qui est décrit dans ce document. En particulier, et sans la limitation, ces droits de propriété intellectuels peuvent inclure un ou plus des brevets américains énumérés à <http://www.sun.com/patents> et un ou les brevets plus supplémentaires ou les applications de brevet en attente dans les Etats-Unis et dans les autres pays.

Ce produit ou document est protégé par un copyright et distribué avec des licences qui en restreignent l'utilisation, la copie, la distribution, et la décompilation. Aucune partie de ce produit ou document ne peut être reproduite sous aucune forme, par quelque moyen que ce soit, sans l'autorisation préalable et écrite de Sun et de ses bailleurs de licence, s'il y en a.

Le logiciel détenu par des tiers, et qui comprend la technologie relative aux polices de caractères, est protégé par un copyright et licencié par des fournisseurs de Sun.

Des parties de ce produit pourront être dérivées des systèmes Berkeley BSD licenciés par l'Université de Californie. UNIX est une marque déposée aux Etats-Unis et dans d'autres pays et licenciée exclusivement par X/Open Company, Ltd.

Sun, Sun Microsystems, le logo Sun, Java, AnswerBook2, docs.sun.com, et Solaris, StorageTek, VolSafe, TimberWolf, TimberLine, and RedWood sont des marques de fabrique ou des marques déposées de Sun Microsystems, Inc. aux Etats-Unis et dans d'autres pays.

Toutes les marques SPARC sont utilisées sous licence et sont des marques de fabrique ou des marques déposées de SPARC International, Inc. aux Etats-Unis et dans d'autres pays. Les produits portant les marques SPARC sont basés sur une architecture développée par Sun Microsystems, Inc.

L'interface d'utilisation graphique OPEN LOOK et Sun™ a été développée par Sun Microsystems, Inc. pour ses utilisateurs et licenciés. Sun reconnaît les efforts de pionniers de Xerox pour la recherche et le développement du concept des interfaces d'utilisation visuelle ou graphique pour l'industrie de l'informatique. Sun détient une licence non exclusive de Xerox sur l'interface d'utilisation graphique Xerox, cette licence couvrant également les licenciées de Sun qui mettent en place l'interface d'utilisation graphique OPEN LOOK et qui en outre se conforment aux licences écrites de Sun.

LA DOCUMENTATION EST FOURNIE "EN L'ÉTAT" ET TOUTES AUTRES CONDITIONS, DECLARATIONS ET GARANTIES EXPRESSES OU TACITES SONT FORMELLEMENT EXCLUES, DANS LA MESURE AUTORISEE PAR LA LOI APPLICABLE, Y COMPRIS NOTAMMENT TOUTE GARANTIE IMPLICITE RELATIVE A LA QUALITE MARCHANDE, A L'APTITUDE A UNE UTILISATION PARTICULIERE OU A L'ABSENCE DE CONTREFAÇON.

We welcome your feedback. Please contact the Sun Learning Services Feedback System at:

[SLSFS@Sun.com](mailto:SLSFS@Sun.com)

or

Sun Learning Services  
Sun Microsystems, Inc.  
One StorageTek Drive  
Louisville, CO 80028-3256  
USA

Please include the publication name, part number, and edition number in your correspondence if they are available. This will expedite our response.

# Summary of Changes

---

<b>EC</b>	<b>Date</b>	<b>Edition</b>	<b>Description</b>
111666	August 2001	First	Initial release
111717	January 2002	Second	Refer to this edition for a description of the changes.
111732	March 2002	Third	Refer to this edition for a description of the changes.
111784	August 2002	Fourth	Refer to this edition for a description of the changes.
111828	February 2003	Fifth	Refer to this edition for a description of the changes.
111854	June 2003	Sixth	Refer to this edition for a description of the changes.
111875	November 2003	Seventh	Refer to this edition for a description of the changes.
111923	July 2004	Eighth	Refer to this edition for a description of the changes.
111948	January 2005	Ninth	Refer to this edition for a description of the changes.
111976	May 2005	Tenth	Refer to this edition for a description of the changes.
114172	October 2006	L	Cover, Copyright, Preface: Added Sun verbiage and branding.  Chapter 2: Updated <a href="#">Table 2-5</a> , <a href="#">Table 2-6</a> and <a href="#">Table 2-7</a> .

---

This page intentionally left blank.

# Contents

---

<b>Summary of Changes</b> .....	<b>iii</b>
<b>Contents</b> .....	<b>v</b>
<b>Figures</b> .....	<b>viii</b>
<b>Tables</b> .....	<b>ix</b>
<b>Preface</b> .....	<b>xi</b>
Organization .....	xii
Alert Messages .....	xii
Mensajes de alerta .....	xii
Conventions .....	xiii
Related Publications .....	xiv
Additional Information .....	xv
Sun's External Web Site .....	xv
Customer Resource Center .....	xv
Partners Site .....	xv
Global Services Support Tools .....	xvi
Documents on CD .....	xvi
Hardcopy Publications .....	xvi
<b>Safety</b> .....	<b>xvii</b>
Safety Precautions .....	xvii
Lifting Techniques .....	xviii
Shoulder, Elbow, Wrist, and Hand Safety .....	xviii
Rack Safety and Precautions .....	xix
Fiber-optic Safety .....	xix
Laser Product Label .....	xx
Fiber-optic Cable Installation .....	xx
Fiber-optic Cable Handling .....	xxi
Electrostatic Discharge (ESD) Damage Prevention .....	xxii
ESD Precautions .....	xxii
ESD-Protection Procedure .....	xxiii
Prepare the Work Area .....	xxiii
Access the Equipment .....	xxiii
Replace Components .....	xxiii
Clean Up .....	xxiv

<b>Seguridad</b> .....	<b>xxv</b>
Precauciones de seguridad .....	xxv
Técnicas de levantamiento de objetos .....	xxvi
Seguridad de hombros, codos, muñecas y manos .....	xxvi
Seguridad y precauciones del bastidor .....	xxvii
Seguridad de fibras ópticas .....	xxvii
Etiqueta del producto láser .....	xxviii
Instalación de cables de fibra óptica .....	xxix
Manipulación de cables de fibra óptica .....	xxix
Prevención de daños por descargas electrostáticas (DES) .....	xxx
Precauciones contra descargas electrostáticas .....	xxx
Procedimiento de protección contra descargas electrostáticas .....	xxxi
Prepare el área de trabajo .....	xxxi
Acceda al equipo .....	xxxi
Sustituya los componentes .....	xxxi
Limpie .....	xxxi
<b>1: Hardware Installation</b> .....	<b>1-1</b>
Quick Installation Procedure .....	1-1
Standard Installation Procedure .....	1-4
Preparing for the Installation .....	1-5
Unpacking the Library .....	1-5
Inspecting the Library and Drives .....	1-8
Preparing the Installation Location .....	1-8
Positioning the Library .....	1-9
Desktop Installation .....	1-9
Rack Installation .....	1-9
Choosing SCSI HVD or LVD .....	1-12
SCSI Cable Restrictions .....	1-12
Host Bus Adapter Requirements .....	1-13
SCSI Device/Bus Type Issues .....	1-13
Installing the External Fibre Channel Router .....	1-14
Connecting the External SCSI Cables .....	1-14
Connecting Fiber and SCSI Cables .....	1-16
Attaching the Personality Module .....	1-18
Attaching the Cell Barrier Clip .....	1-19
Inserting the Cartridges .....	1-20
Drive Compatibility Issues .....	1-23
Installing the Drives .....	1-26
Powering-on the Library and Drives .....	1-29
Recording the Configuration Information .....	1-29



<b>2: Locations, Specifications, and Cables</b> .....	<b>2-1</b>
Locations .....	2-1
Specifications .....	2-6
Library Environment .....	2-6
Library Power .....	2-7
Drive and Cartridge Weights .....	2-7
Drive Power .....	2-8
Power Cord Numbers and Receptacles .....	2-11
External Cables .....	2-12
<b>A: SNMP</b> .....	<b>A-1</b>
Overview .....	A-1
SNMP Terms .....	A-3
SNMP Commands .....	A-4
Access Control .....	A-4
Management Information Base .....	A-4
Configuration .....	A-6
Starting SNMP .....	A-7
<b>Index</b> .....	<b>Index-1</b>

# Figures

---

Figure 1-1. Unpacking the Library .....	1-6
Figure 1-2. Attaching the Cell Barrier Clip .....	1-19
Figure 1-3. Determining the Valid Storage Cells .....	1-21
Figure 1-4. Inserting the Cartridges .....	1-22
Figure 2-1. Front View of Components .....	2-1
Figure 2-2. Rear View of Components .....	2-2
Figure 2-3. Internal View of Components .....	2-4
Figure 2-4. Robotic Components .....	2-5
Figure 2-5. DLT Drive Label Locations .....	2-5
Figure 2-6. Ultrium Drive Label Locations .....	2-6
Figure 2-7. L40 Desktop Version Dimensions and Weight .....	2-9
Figure 2-8. L40 Rack Version Dimensions and Weight .....	2-10

# Tables

---

Table 1-1. SCSI Cable Length Restrictions .....	1-13
Table 1-2. SCSI Device/Bus Types: Issues .....	1-13
Table 1-3. LTO Drive Backward Readability .....	1-24
Table 1-4. SCSI Device/Bus Types: Issues .....	1-24
Table 1-5. Compatible Drives and Interfaces .....	1-25
Table 1-6. L40 Tape Library Configuration Information .....	1-30
Table 2-1. Library Environment Specifications .....	2-6
Table 2-2. Library Power Specifications .....	2-7
Table 2-3. Drive and Cartridge Weights .....	2-7
Table 2-4. Drive Power Specifications .....	2-8
Table 2-5. Country-specific Power Cords .....	2-11
Table 2-6. Non-country-specific Power Cords .....	2-11
Table 2-7. External Cables .....	2-12



# Preface

---

This manual is for either customers or service representatives, depending upon the service contract. When you have completed the procedures in this manual, refer to the user's guide to configure your library. See [“Related Publications”](#) on page xiv.

Most of the information pertains to library hardware. For specific drive information or for client-generated software commands and console messages, refer to your drive or software documentation.

## ■ Organization

This manual has two chapters, an appendix, and an index:

- Chapter 1**     [“Hardware Installation”](#) tells you how to install the hardware portions of the library. It contains a “Quick Installation Procedure” for experienced users and a “Standard Installation Procedure” that guides you through each step of the installation.
- Chapter 2**     [“Locations, Specifications, and Cables”](#) identifies library components, drive label locations, specifications, and external cable part numbers.
- Appendix A**   [“SNMP”](#) provides the implementation of the Simple Network Management Protocol (SNMP).
- Index**         The [Index](#) helps you locate information.

## ■ Alert Messages

Alert messages call your attention to information that is especially important or that has a unique relationship to the main text or graphic.

**Note:** A note provides additional information that is of special interest. A note might point out exceptions to rules or procedures. A note usually, but not always, follows the information to which it pertains.

**CAUTION:**

**A caution informs you of conditions that might result in damage to hardware, corruption of data, or corruption of application software. A caution always precedes the information to which it pertains.**

**WARNING:**

**A warning alerts you to conditions that might result in long-term health problems, injury, or death. A warning always precedes the information to which it pertains.**

## ■ Mensajes de alerta

Los mensajes de alerta llaman la atención hacia información de especial importancia o que tiene una relación específica con el texto principal o los gráficos.

**Nota:** Una nota expone información adicional que es de interés especial. Una nota puede señalar excepciones a las normas o procedimientos. Por lo general, aunque no siempre, las notas van después de la información a la que hacen referencia.

**PRECAUCIÓN:**

**Una precaución informa sobre situaciones que podrían conllevar daños del hardware, de los datos o del software de aplicación. Las precauciones van siempre antes de la información a la que hacen referencia.**

**ADVERTENCIA:**

**Una advertencia llama la atención sobre condiciones que podrían conllevar problemas de salud crónicos, lesiones o muerte. Las advertencias van siempre antes de la información a la que hacen referencia.**

## ■ Conventions

Typographical conventions highlight special words, phrases, and actions in this publication.

Item	Example	Description of Convention
Buttons	<b>MENU</b>	Font and capitalization follows label on product
Commands	Mode Select	Initial cap
Document titles	<i>System Assurance Guide</i>	Italic font
Emphasis	<i>not</i> or <i>must</i>	Italic font
File names	<code>esc.txt</code>	Monospace font
Hypertext links	<a href="#">Figure 2-1 on page 2-5</a>	Blue (prints black in hardcopy publications)
Indicators	<i>Open</i>	Font and capitalization follows label on product
Jumper names	TERMPWR	All uppercase
Keyboard keys	<Y> <Enter> or <Ctrl+Alt+Delete>	Font and capitalization follows label on product; enclosed within angle brackets
Menu names	Configuration Menu	Capitalization follows label on product
Parameters and variables	Device = <i>xx</i>	Italic font
Path names	<code>c:/mydirectory</code>	Monospace font
Port or connector names	SER1	Font and capitalization follows label on product; otherwise, all uppercase
Positions for circuit breakers, jumpers, and switches	ON	Font and capitalization follows label on product; otherwise, all uppercase
Screen text (including screen captures, screen messages, and user input)	<code>downloading</code>	Monospace font
Switch names	<b>Power</b>	Font and capitalization follows label on product
URLs	<a href="http://www.sun.com">http://www.sun.com</a>	Blue (prints black in hardcopy publications)

## ■ Related Publications

Refer to the following publications for additional information:

<b>Library Documentation</b>	<b>Part Number</b>
<i>L40 Tape Library Ordering Guide</i>	MT5011
<i>L40 Tape Library Service Manual</i>	96026
<i>L40 Tape Library User's Guide</i>	96005
<i>L40/80 Tape Library CRU Instructions</i>	96031
<i>L40/80 Tape Library Drives CRU Instructions</i>	96006

<b>Tape Drive Documentation</b>	<b>Part</b>
<i>DLT 7000 Tape Drive Product Manual</i>	31313450x
<i>DLT 8000 Tape Drive Product Manual</i>	Quantum: 81-60118-0x
<i>DLT1 Installation and Operations Guide</i>	Benchmark: 000826-0x
<i>DLT1 Product Specification</i>	Benchmark: 000827-0x
<i>SDLT 220, 320 and 600 Product Manual</i>	CD included with drive
Hewlett Packard LTO Ultrium Publication	CD included with drive
IBM LTO Ultrium Publication	CD included with drive
Quantum's Certance LTO Ultrium Publication	CD included with drive

<b>Other Publications</b>	<b>Part Number</b>
<i>American National Standard Dictionary for Information Processing Systems</i>	ANSI X3/TR-1-82
<i>American National Standard Magnetic Tape and Cartridge for Information Interchange</i>	ANSI X3B5/87-009
<i>Crossroads Fibre Router User's Manual</i>	DS30110
<i>StorageNet 3300 Fibre Channel Router User Manual</i>	461273-01
<i>Fiber Optic User's Guide</i>	9433
<i>Magnetic Tape Labels and File Structure for Information Interchange</i>	ANSI X3.27-1978
<i>SCSI-3 Parallel Interface (SPI)</i>	ANSI X3T9.2/91-010R7
<i>Small Computer System Interface</i>	ISO 9316:1989



## ■ Additional Information

Sun Microsystems, Inc. (Sun) offers several methods for you to obtain additional information.

### Sun's External Web Site

Sun's external Web site provides marketing, product, event, corporate, and service information. The external Web site is accessible to anyone with a Web browser and an Internet connection.

The URL for the external Web site is: <http://www.sun.com>

The URL for StorageTek™ brand-specific information is:  
<http://www.sun.com/storagetek/>

### Customer Resource Center

The Sun StorageTek product Customer Resource Center (CRC) is a Web site that enables members to resolve technical issues by searching code fixes and technical documentation for StorageTek brand products. CRC membership entitles you to other proactive services, such as HIPER subscriptions, technical tips, answers to frequently asked questions, addenda to product documentation books, and online product support contact information. Customers who have a current warranty or a current maintenance service agreement may apply for membership by clicking on the Request Password button on the CRC home page. Sun employees may enter the CRC through the SunWeb PowerPort.

The URL for the CRC is <http://www.support.storagetek.com>

### Partners Site

The StorageTek Partners site is a Web site for partners with a StorageTek Partner Agreement. This site provides information about products, services, customer support, upcoming events, training programs, and sales tools to support StorageTek Partners. Access to this site, beyond the Partners Login page, is restricted. On the Partners Login page, employees and current partners who do not have access can request a login ID and password and prospective partners can apply to become StorageTek resellers.

The URL for the StorageTek Partners site is:  
<http://members.storagetek.com>

The URL for partners with a Sun Partner Agreement is:  
<http://www.sun.com/partners/>

## Global Services Support Tools

Global Services Support Tools site (also called Field Tools) provides tools that aid in the sales and support of Sun StorageTek brand products and services. This is an internal Web site for employees.

The URL for the Global Services Support Tools is [http://sunsolve.central.sun.com/handbook\\_internal/FieldTools](http://sunsolve.central.sun.com/handbook_internal/FieldTools)

## Documents on CD

*Documents on CD* (3106600xx) contains portable document format (PDF) files of Sun StorageTek brand product publications. To order Documents on CD, contact your local Customer Services Logistics Depot. *Documents on CD* is only for employees.

## Hardcopy Publications

You may order paper copies of publications listed on the CRC or included on the *Documents on CD*.

Service publications have *numeric* part numbers. To order paper copies of service publications, contact your local Customer Services Logistics Depot.

# Safety

---

The following pages describe common practices concerning electrical safety, ergonomics, rack installation, fiber optics, and electrostatic discharge.

## ■ Safety Precautions

### **WARNING:**

***Potential injury:* On-the-job safety is important; therefore, observe the following safety precautions while you are engaging in any maintenance activity. Failing to follow these precautions could result in serious injury.**

**Remove all conductive jewelry, such as watches and rings, before you service powered-on equipment.**

- Avoid electrical shock. Be careful when you work near power connectors and supplies.
- Power-off the equipment that is being serviced before you remove a field replaceable unit (FRU) or other component. Remember that dangerous voltages could still be present in some areas even though power is off.
- Ground all test equipment and power tools.
- Lift objects properly; read the information in [“Lifting Techniques” on page -xviii](#).
- Do not remove, cut, or relocate any floor tiles indiscriminately. Before you manipulate floor tiles, be sure that you understand the customer’s environment and receive the customer’s approval. Remember, each situation is different.
- Enforce good housekeeping practices in the equipment area to help prevent fire and accidents.

**Note:** Important things to investigate and to be aware of include the use of Halon® gas, under-the-floor smoke detectors, and cables to other equipment installed nearby.

## ■ Lifting Techniques

Lifting, regardless of how much or how little, can create serious back stress. If you follow these guidelines, you can reduce the risk of back injury:

- Do not twist your body to pick up something or to put it down. Twisting puts extreme pressure on your back, especially when you lift or carry objects. Instead of twisting, make the task two separate moves; first lift, and then use your feet to turn your body.
- Plan the lift: first examine the object and then determine how it will be lifted and where it will be placed.
- Choose the appropriate lifting technique. Examine the weight, size, location, frequency, and direction of the lift. Plan to avoid awkward postures, and determine if material-handling aids are needed.
- Place your feet shoulder-width apart, and place one foot a little behind the other. Keep your back straight because even light loads can significantly increase pressure on your spine when you lean forward.
- Whenever you can, grip the load with your whole hand, and use two hands.
- Carry objects at elbow height and close to your body. The farther away you hold an object, the more force it puts on your lower back.
- Lift with your legs instead of your back. Leg muscles are some of the strongest in the body. When you squat and lift with your legs, you can lift more weight safely.
- Alternate lifting tasks with tasks that are less stressful to the same muscles. This technique ensures that your muscles have some recovery time.

## Shoulder, Elbow, Wrist, and Hand Safety

Follow these guidelines to minimize the possibility of injury to your shoulders, elbows, wrists, and hands.

- Work within your safety zone—the area between shoulder level and knuckle level of your lowered hands. You face less chance of injury when you work or lift in this area.
- Keep your elbows bent to keep loads close to your body and to decrease the amount of force necessary to do the job. If you use this posture, you will put less weight and pressure on your shoulder.
- Be sure to keep your wrists straight. Avoid bending, extending, or twisting your wrists for long periods of time.
- Do not use a pinch grip to lift large or heavy loads because the way you lift also can affect the tendons in your hand. When you grasp an object between your thumb and fingers, you put a lot of tension on hand and wrist tendons. Use both hands—use one for a while, and then use the other—to give them rest.

## ■ Rack Safety and Precautions

### **WARNING:**

#### ***Possible personal injury:***

- ***Lifting hazard:*** The library weighs 44.45 kg (98 lb) plus the weight of the drives. Use at least two people and a mechanical device to lift and position the library. Make sure you read the information in **“Lifting Techniques” on page xviii** before beginning.
- **Also consider the library’s total weight when you are placing other equipment into the rack. To prevent an unbalanced situation, install the heaviest equipment on the bottom and the lightest equipment on the top. Failure to do so might cause the rack to become unstable and tip over.**

Observe the following safety precautions when you are installing the library into a rack:

- If the rack has front or rear doors, do *not* allow the doors to interfere with the library’s ventilation. The rack’s internal ambient temperature should not exceed the recommended operating temperature range of the library. The maximum rack air ambient temperature is 40°C (104°F).
- Ensure that rack doors provide adequate clearance to the library.
- Ensure that the combination of the library with other equipment in the rack does not create an overcurrent condition, whether the equipment is connected directly to the branch circuit or to a power distribution strip.
- Ensure that all equipment in the rack has reliable earth ground, whether the equipment is connected directly to the branch circuit or to a power distribution strip.

**Note:** The library relies on the ground pin of the power cord for its earth ground.

## ■ Fiber-optic Safety

### **WARNING:**

***Eye hazard.*** Never look directly into a fiber-optic cable, a fiber-optic connector, or a laser transceiver module. Hazardous conditions might exist from laser power levels that are capable of causing injury to the eye.

**Be especially careful when using optical instruments with this equipment. Such instruments might increase the likelihood of eye injury.**

The laser transceivers in fiber-optic equipment can pose dangers to personal safety. Ensure that anyone who works with this Sun StorageTek equipment understands these dangers and follows safety procedures. Ensure that the optical ports of every laser transceiver module are terminated with an optical connector, a dust plug, or a cover.

Each fiber-optic interface in this Sun StorageTek Fibre Channel equipment contains a laser transceiver that is a Class 1 Laser Product. Each laser transceiver has an output of less than 70  $\mu$ W and a wavelength of 850 nm. Sun StorageTek's Class 1 Laser Products comply with EN60825-1(+A-11) and with sections 21 CFR 1040.10 and 1040.11 of the Food and Drug Administration (FDA) regulations.

The following translations are for users in Finland and Sweden who wish to identify laser safety and classification:

CLASS 1 LASER  
LUOKAN 1 LASERLAITE  
KLASSE 1 LASER APPARAT

## Laser Product Label

In accordance with safety regulations, a label on each Sun StorageTek Fibre Channel product identifies the laser class of the product and the place and date of the manufacturer. The label appears on top of a Fibre Channel tape drive and near the Fibre Channel connectors on a Fibre Channel tape library. A copy of the label is shown here:

---

CLASS 1 LASER PRODUCT  
LASER KLASSE 1  
APPAREIL A LASER DE CLASSE 1  
COMPLIES WITH 21 CFR 1040.10 AND 1040.11

---

## Fiber-optic Cable Installation

Follow these guidelines when you install fiber-optic cables:

### 1. Cable routing:

- **Raised floor:** You may install fiber-optic cables under a raised floor. Route them away from any obstruction, such as existing cables or other equipment.
- **Cable tray or raceway:** Place the cables in position; do not pull them through the cable tray. Route the cables away from sharp corners, ceiling hangers, pipes, and construction activity.
- **Vertical rise length:** Leave the cables on the shipping spool, and lower them from above; do not pull the cables up from below. Use proper cable ties to secure the cable.
- **General:** Do not install fiber-optic cables on top of smoke detectors.

## **2. Cable management:**

- Leave at least 4.6 m (15 ft) of cable at each end for future growth.
- Use strain reliefs to prevent the weight of the cable from damaging the connector.
- Review all information in this manual and in any related manuals about safely handling fiber-optic cables.

## **3. Connector protection:**

- Insert connectors carefully to prevent damage to the connector or fiber.
- Leave the connector's protective cover in place until you are ready to make connections.
- Replace the connector's protective cover when the connector is disconnected.
- Clean the connector before making a connection. Make sure that there are no obstructions and that keyways are aligned.

# **Fiber-optic Cable Handling**

Observe these precautions when you handle fiber-optic cables:

- Do not coil the cable to less than 96 mm (3.75 in.) in diameter.
- Do not bend the cable to less than 12 mm (0.5 in.) in radius. It is most important that a cable's bend radius be no less than 20 times the diameter of the cable.
- Do not pull on the cables; carefully place them into position.
- Do not grasp the cables with pliers, grippers, or side cutters; do not attach pulling devices to the cables or connectors.
- Keep cables away from sharp edges or sharp protrusions that could cut or wear through the cable; make sure that cutouts in the equipment have protective edging.
- Protect the cable from extreme temperature conditions.
- Install the connector's protective cover whenever the connector is not connected.

## ■ Electrostatic Discharge (ESD) Damage Prevention

Anyone who handles ESD-sensitive components must be aware of the damage that ESD can cause to electronic components and must take the proper precautions to prevent it. Also, anyone who performs maintenance on Sun StorageTek equipment must complete an ESD-basics course.

### **CAUTION:**

***Potential damage to equipment: Handle ESD-sensitive components only under ESD-protected conditions. To meet this requirement, always use the Field Service Grounding Kit (PN 4711) and always follow these ESD precautions and procedures when you are servicing Sun StorageTek equipment or handling ESD-sensitive components.***

## ESD Precautions

Always take the following general precautions when you work with ESD-sensitive components:

- Wear ESD protection whenever you install, remove, maintain, or repair Sun StorageTek equipment.
- Keep ESD-sensitive printed-circuit components in their ESD-protective packages until you have taken all ESD-preventive steps and you are ready to install the component.
- Do not allow anyone to touch or handle an unprotected ESD-sensitive component unless that person has taken all ESD precautions.
- Reinstall all equipment covers and close all equipment doors after you have completed the work.
- If the grounding-kit work surface has been exposed to temperatures above 66°C (150°F) or below 4.5°C (40°F), acclimate the work surface to room temperature before you unroll it.
- Immediately place any component that you have removed into an ESD-protective package.
- Keep the grounding-kit work surface clean.

**Note:** To clean the work surface, use a mild detergent and water, and make sure that the surface is completely dry before you use it.

- Periodically check the electrical resistance of the ground cord and the wrist-strap coil cord.

**Note:** The ground cord should measure less than 1.2 M $\Omega$ , and the coil cord should measure between 0.8 and 1.2 M $\Omega$ . Repair or replace the cords if they no longer meet these requirements.



# ESD-Protection Procedure

Remember that each customer environment is different. Address all the customer's concerns before you work on any equipment.

## Prepare the Work Area

1. Before you service the equipment, unfold the grounding-kit work surface completely and place it on a convenient surface.
2. Attach one end of the ground cord to the work surface; secure the snap fastener.

**Note:** You will attach the free end in a later step.

3. Slip on an ESD wrist strap. Make sure that the strap is comfortable and makes contact with the entire circumference of your wrist.
4. Snap one end of the coil cord to the wrist band.

## Access the Equipment

5. Carefully open the doors to the equipment or remove the covers from the equipment. Do not touch any internal components.

### **CAUTION:**

**Be sure that you are properly grounded before you touch any internal components.**

6. Attach the free end of the coil cord to the most appropriate place:
  - a. If you are working on components from a small piece of equipment, attach the free end of the coil cord to the grounding-kit work surface. In addition, be sure that you touch an unpainted metal surface on the equipment before you touch an internal component.
  - b. If you are working on components from a large piece of equipment, attach the free end of the coil cord to a grounding jack or to an unpainted metal surface inside the equipment.

## Replace Components

7. Remove the defective component and place it on the work surface.
8. Remove the replacement component from its ESD-protective package, and install the component in the equipment.
9. Place the defective component in the ESD-protective package.

## **Clean Up**

10. Disconnect the ground cords from the equipment.
11. Reinstall all equipment covers and close all equipment doors.
12. Disconnect the coil cord from your wrist, and, if necessary, disconnect the ground cord from the work surface.
13. Properly store the work surface and the other Field Service Grounding Kit items.

# Seguridad

---

Las siguientes páginas describen prácticas habituales sobre seguridad eléctrica, ergonomía, instalación en bastidor, fibras ópticas y descargas electrostáticas.

## ■ Precauciones de seguridad

### **ADVERTENCIA:**

***Posibles lesiones:* la seguridad durante el trabajo es importante; por ello, atienda a las siguientes precauciones de seguridad mientras esté realizando alguna actividad de mantenimiento. El incumplimiento de dichas precauciones puede conllevar graves lesiones.**

**Antes de realizar cualquier tarea en equipos eléctricos conectados, quítese las joyas y accesorios conductores de electricidad, como relojes y anillos.**

- Evite las descargas eléctricas. Tenga cuidado al trabajar en la proximidades de conectores y alimentaciones eléctricas.
- Antes de extraer unidad sustituible in situ u otro componente, apague el equipo y desconéctelo de la red eléctrica. Recuerde que, incluso si están apagados, en algunas áreas pueden quedar tensiones peligrosas.
- Ponga a tierra todos los equipos de prueba y herramientas eléctricas.
- Para levantar objetos, consulte la información de [“Técnicas de levantamiento de objetos”](#) (véase a continuación).
- No quite, corte ni cambie de lugar indiscriminadamente las baldosas. Antes de manipular baldosas, asegúrese de conocer el entorno del cliente y de recibir su autorización. Recuerde que cada situación es diferente.
- Aplique las prácticas adecuadas de limpieza en el área del equipo para prevenir incendios y accidentes.

**Nota:** Entre los factores importantes que deben tenerse en cuenta es la presencia de gas Halón®, detectores de humo subterráneos y cables conductores a otros equipos instalados en las proximidades.

## Técnicas de levantamiento de objetos

El levantar equipos o componentes, independientemente de su peso o tamaño, puede provocar serias lesiones lumbares. Siguiendo estas directrices podrá reducir los riesgos de lesiones.

- No incline el cuerpo para levantar o bajar algo. Esta posición supone una tensión extrema para la espalda, en especial al levantar o transportar objetos. En lugar de inclinarse, efectúe dos movimientos: primero levante el componente y, a continuación, utilice los pies para girar el cuerpo.
- Planifique el levantamiento: primero examine el objeto y, a continuación, determine cómo lo levantará y dónde lo colocará.
- Seleccione la técnica de levantamiento adecuada. Examine el peso y tamaño del objeto, su ubicación y frecuencia y dirección en que vaya a levantarlo. La planificación debe hacerse de tal modo que se eviten posturas incómodas. Determine si son necesarios accesorios para la manipulación de materiales.
- Separe bien las piernas y coloque una ligeramente detrás de la otra. Mantenga la espalda recta, porque incluso pesos ligeros pueden incrementar significativamente la presión sobre la espina dorsal al inclinarse hacia adelante.
- En la medida de lo posible, sostenga la carga con toda la mano, y utilice ambas manos.
- Transporte los objetos a la altura del codo y próximos a su cuerpo. Cuanto más lejos tenga que transportar un objeto, más presión aplicará sobre la zona lumbar.
- Levante el objeto haciendo fuerza con las piernas, y no con la espalda. Los músculos de las piernas se cuentan entre los más fuertes del cuerpo. Al acuclillarse y levantar un peso con las piernas, tendrá mayor tolerancia al peso.
- Alterne estas tareas con otras menos pesadas para los mismos músculos. De este modo, los músculos dispondrán de un cierto tiempo de recuperación.

## Seguridad de hombros, codos, muñecas y manos

Siga estas instrucciones para reducir al mínimo las posibilidades de lesionarse los hombros, codos, muñecas y manos.

- Trabaje dentro de su zona de seguridad, el área entre el nivel de los hombros y el nivel de los nudillos. Trabajando o levantando objetos dentro de esta área se expondrá a menos probabilidades de lesiones.
- Mantenga los codos inclinados para mantener las cargas próximas a su cuerpo y reducir la fuerza necesaria para realizar la tarea. Con esta postura, aplicará menos peso y presión sobre los hombros.
- Asegúrese de mantener las muñecas rectas. Evite doblarlas, extenderlas o torcerlas durante períodos de tiempo prolongados.

- No levante cargas grandes o pesadas con el puño cerrado, porque el modo de levantarlas también afecta a los tendones de la mano. Al tomar un objeto entre el pulgar y los dedos se aplica mucha tensión a las manos y tendones de las muñecas. Utilice ambas manos alternativamente, para permitir que descansen.

## ■ Seguridad y precauciones del bastidor

### **ADVERTENCIA:**

#### ***Posibilidad de lesiones físicas:***

- ***Peligro de levantamiento:*** La biblioteca pesa 44,45 kg (98 lb), a lo que hay que añadir el peso de las unidades. Para levantar la biblioteca y colocarla en su posición se requieren como mínimo dos personas. Antes de poner manos a la obra, asegúrese de leer la información presentada en “[Técnicas de levantamiento de objetos](#)” en la [página xxvi](#).
- **Al colocar otros equipos en el bastidor, considere también el peso total de la biblioteca. Para evitar un desequilibrio de la carga, coloque los equipos más pesados abajo y los más ligeros arriba. De lo contrario, el bastidor podría desestabilizarse y caerse.**

Al instalar la biblioteca en el bastidor, adopte las siguientes precauciones de seguridad:

- Si el bastidor tiene puertas delanteras o traseras, *no permita* que las puertas interfieran con la ventilación de la biblioteca. La temperatura ambiente en el interior del bastidor no debe ser superior a la temperatura de servicio recomendada de la biblioteca. La temperatura ambiente máxima del interior del bastidor es de 40 °C (104 °F).
- Asegúrese de que las puertas del bastidor permitan el acceso adecuado a la biblioteca.
- Asegúrese de que la combinación de la biblioteca con otros equipos instalados en el bastidor no provoque situaciones de sobretensión, tanto si el equipo está conectado directamente al circuito derivado o a una regleta de distribución.
- Asegúrese de que todos los equipos del bastidor dispongan de una puesta a tierra fiable, tanto si el equipo está directamente conectado al circuito derivado o a una regleta de distribución

**Nota:** La puesta a tierra de la biblioteca se conecta a través de la patilla de puesta a tierra del enchufe.

## ■ Seguridad de fibras ópticas

### **ADVERTENCIA:**

***Riesgo para la vista.*** Nunca mire directamente el interior de un cable de fibra óptica, un conector de fibra óptica o un módulo transceptor de láser. Los niveles de potencia del láser pueden conllevar situaciones de riesgo, susceptibles de lesionar la vista.

**Tenga especial cuidado al utilizar instrumentos ópticos con estos equipos. Dichos instrumentos pueden incrementar las probabilidades de lesiones oculares.**

Los transceptores de láser de los equipos de fibra óptica pueden suponer un peligro para la seguridad física. Asegúrese de que toda persona que trabaje con estos equipos de Sun StorageTek entienda los peligros y siga los procedimientos de seguridad. Asegúrese de que todos los puertos ópticos de los módulos transceptores de láser estén terminados con un conector óptico, una cubierta o un tapón de protección contra el polvo.

Todas las interfaces de fibra óptica de estos equipos de canal de fibra de Sun StorageTek contienen un transceptor de láser, categorizado como Producto láser de Clase 1. Cada transceptor láser tiene una salida de menos de 70  $\mu\text{W}$  y una longitud de onda de 850 nm. Los productos de láser de clase 1 de Sun StorageTek cumplen las normas EN60825-1(+A-11) y las secciones 21 CFR 1040.10 y 1040.11 de las normas de la Administración para la Calidad de Alimentos y Medicamentos (FDA).

Las siguientes traducciones están dirigidas a usuarios de Finlandia y Suecia que deseen identificar la categoría y clasificación de seguridad de los dispositivos láser:

LÁSER DE CLASE 1  
LUOKAN 1 LASERLAITE  
KLASSE 1 LASER APPARAT

## Etiqueta del producto láser

De conformidad con las normas de seguridad, cada producto de canal de fibra de Sun StorageTek lleva una etiqueta que identifica la clase de láser del producto, y el lugar y fecha de fabricación. Esta etiqueta aparece sobre la unidad de cinta de canal de fibra, así como en las proximidades de los conectores de las bibliotecas de cintas de canal de fibra. A continuación puede verse una copia de dicha etiqueta:

---

CLASS 1 LASER PRODUCT  
LASER KLASSE 1  
APPAREIL A LASER DE CLASSE 1  
CUMPLE LAS NORMAS 21 CFR 1040.10 Y 1040.11

---

## Instalación de cables de fibra óptica

Para instalar cables de fibra óptica, efectúe este procedimiento:

### 1. Tendido del cable:

- **Tarima:** Los cables de fibra óptica pueden instalarse debajo de tarimas. Al tenderlos, manténgalos apartados de cualquier obstrucción, como por ejemplo otros cables o equipos.
- **Escalerilla portacables o canaleta de cables:** Sitúe los cables en su posición. No tire de ellos a través de la escalerilla portacables. Al tender los cables, manténgalos apartados de esquinas afiladas, colgadores de techo, conductos, tuberías y actividades de construcción.
- **Longitud de elevación vertical:** Deje los cables en la bobina original y bájelos desde arriba. No tire de ellos desde abajo. Utilice los fijadores adecuados para inmovilizarlos.
- **General:** No instale cables de fibra óptica encima de detectores de humo:

### 2. Instalación de los cables:

- Deje como mínimo 4,6 m (15 pies) de cable en cada extremo, en previsión de futuras extensiones.
- Utilice protectores contra tirones para evitar que el peso del cable dañe el conector.
- Repase en el presente manual, así como de manuales afines, toda la información relativa a la manipulación segura de cables de fibra óptica.

### 3. Protección de los conectores:

- Inserte los conectores con todo cuidado para evitar dañar éstos o la fibra.
- No quite la cubierta de protección del conector hasta que esté preparado para realizar las conexiones.
- Al desconectar el conector, vuelva a colocar la cubierta de protección.
- Antes de realizar una conexión, limpie el conector. Asegúrese de que no haya obstrucciones y de que las ranuras de chavetas estén alineadas.

## Manipulación de cables de fibra óptica

Al manipular cables de fibra óptica, tenga en cuenta las siguientes precauciones:

- No enrolle el cable a menos de 96 mm (3,75") de diámetro.
- No curve el cable a menos de 12 mm (0,5") de radio. Se recomienda que el radio de curvatura de un cable no sea inferior a 20 veces el diámetro del cable.
- No tire de los cables: colóquelos con cuidado en su posición.

- No aferre los cables con alicates, pinzas ni fresas. No una los cables ni los conectores a dispositivos de tracción.
- Mantenga los cables apartados de bordes y salientes afilados que pudieran cortarlos o desgastarlos. Asegúrese de que los orificios del equipo dispongan de bordes protectores.
- Proteja los cables contra temperaturas extremas.
- En toda ocasión en que el conector no esté conectado, colóquelo su cubierta de protección.

## ■ Prevención de daños por descargas electrostáticas (DES)

Quienes manipulan componentes sensibles a las descargas electrostáticas (DES) deben ser conscientes de los daños que éstas pueden provocar en los componentes electrónicos, con el objeto de adoptar las precauciones adecuadas para evitarlas. Asimismo, las personas que realicen tareas de mantenimiento en equipos de Sun StorageTek deben pasar un curso de fundamentos de las descargas electrostáticas.

### **PRECAUCIÓN:**

***Posibles daños a los equipos: Manipule los componentes sensibles a las descargas electrostáticas sólo en las condiciones de protección adecuadas. Para cumplir este requisito, utilice siempre el Kit de puesta a tierra del servicio de campo (NP 4711) y cumpla en todo momento estas precauciones y procedimientos al realizar tareas de mantenimiento o servicio técnico de equipos de Sun StorageTek, así como al manipular componentes sensibles a las descargas electrostáticas.***

## Precauciones contra descargas electrostáticas

Al trabajar con componentes sensibles a las descargas electrostáticas (DES), adopte siempre las siguientes precauciones generales:

- Utilice protección contra descargas electrostáticas a realizar tareas de instalación, desinstalación, mantenimiento o reparación de equipos de Sun StorageTek.
- Mantenga los circuitos impresos sensibles a las descargas electrostáticas dentro de sus embalajes de protección hasta haber adoptado las medidas de prevención adecuadas y esté preparado para instalar el componente.
- No permita que nadie toque o manipule un componente sensible a las descargas electrostáticas no protegido, salvo que dicha persona haya adoptado las precauciones pertinentes.



- Una vez concluido el trabajo, vuelva a colocar todas las cubiertas del equipo y cierre todas las puertas.
- Si la superficie de trabajo del kit de puesta a tierra ha estado sometida a temperaturas superiores a los 66 °C (150 °F) o inferiores a los 4,5 °C (40 °F), deje que la superficie se aclimate a la temperatura ambiente antes de desenrollarla.
- Coloque inmediatamente sobre esta superficie todo componente que haya retirado de su embalaje de protección contra descargas electrostáticas.
- Mantenga limpia la superficie de trabajo del kit de puesta a tierra.

**Nota:** Para limpiarla, utilice agua y un detergente suave, asegurándose de que esté completamente seca antes de utilizarla.

- Compruebe periódicamente la resistencia eléctrica del cable de puesta a tierra y del cable en espiral de la muñequera.

**Nota:** Al medir la resistencia del cable de puesta a tierra, debe ser inferior a 1,2 MΩ; la del cable en espiral debe situarse entre 0,8 y 1,2 MΩ. Repare o sustituya los cables si no cumplen estos requisitos.

## Procedimiento de protección contra descargas electrostáticas

Recuerde que cada entorno de cliente es diferente. Responda a todas las dudas e inquietudes del cliente antes de proceder a trabajar en un equipo.

### Prepare el área de trabajo

1. Antes de reparar el equipo, desenrolle completamente la superficie de trabajo del kit de puesta a tierra y colóquela sobre una superficie adecuada.
2. Conecte un extremo del cable de puesta a tierra a la superficie de trabajo y ajuste el broche de presión.
 

**Nota:** El otro extremo se conectará posteriormente.
3. Colóquese una muñequera antiestática. Asegúrese de que le resulte cómoda y que haga contacto con toda la circunferencia de la muñeca.
4. Conecte a la muñequera un extremo del cable en espiral.

## Acceda al equipo

5. Con todo cuidado, abra las puertas o retire las cubiertas del equipo. No toque ningún componente interno.

### **PRECAUCIÓN:**

**Antes de tocar cualquier componente interno, asegúrese de estar correctamente conectado a tierra.**

6. Conecte el extremo libre del cable en espiral al lugar más adecuado:
  - a. Si está trabajando con componentes de un equipo de pequeñas dimensiones, conecte el extremo libre del cable a la superficie de trabajo del kit de puesta a tierra. Asimismo, asegúrese de tocar una superficie metálica no pintada del equipo antes de tocar cualquier componente interno.
  - b. Si está trabajando con componentes de un equipo de amplias dimensiones, conecte el extremo libre del cable en espiral a un conector de puesta a tierra o a una superficie metálica no pintada del interior del equipo.

## Sustituya los componentes

7. Sustituya el componente defectuoso y colóquelo sobre la superficie de trabajo.
8. Extraiga el componente de recambio de su embalaje de protección contra descargas eléctricas e instálelo en el equipo.
9. Coloque el componente defectuoso dentro del embalaje de protección.

## Limpie

10. Desconecte los cables de puesta a tierra del equipo.
11. Vuelva a instalar todas las cubiertas y cierre todas las puertas del equipo.
12. Desconecte el cable en espiral de la muñeca. Si fuese necesario, desconecte el cable de puesta a tierra de la superficie de trabajo.
13. Pliegue correctamente la superficie de trabajo, y guárdela. Guarde también los demás componentes del Kit de puesta a tierra del servicio de campo.

# Hardware Installation

# 1

This chapter tells you how to install the L40 Tape Library. Two methods are available:

- “[Quick Installation Procedure](#)” for users who have installed other L40 Tape Libraries
- “[Standard Installation Procedure](#)” on page 1-4 for first-time installers who want help with each step of the process

You might need to ask your system administrator for some of the configuration information, such as the network entries.

See [Chapter 2](#) to become familiar with the component locations, specifications, and cables.

## ■ Quick Installation Procedure

If you are experienced with computer equipment and want to install this library with the minimum number of steps, use the following procedure. If you encounter problems, follow the detailed instructions in “[Standard Installation Procedure](#)” on page 1-4.

### **WARNING:**

***Safety first:*** Make sure you read the information in “[Safety](#)” on page xvii before beginning. Use at least two people and a mechanical device to lift and position the library. The library weighs 44.45 kg (98 lb) plus the weight of the drives.

### **ADVERTENCIA:**

***La seguridad es lo primero:*** Antes de poner manos a la obra, asegúrese de leer la información presentada en “[Seguridad](#)” en la página xxv. Para levantar la biblioteca y colocarla en su posición se requieren como mínimo dos personas. La biblioteca pesa 44,45 kg (98 lb), a lo que hay que añadir el peso de las unidades.

**Note:** Rack installation requires special procedures.  
See “[Rack Installation](#)” on page 1-9.

Save all the packing material in case you want to relocate or return the library in the future.

1. Remove the library from its shipping container and place the library on a firm, horizontal surface.
2. Obtain the door key from the accessory container, and unlock and open the front door.

3. Remove the packing cushion and foam.
4. Visually inspect the library and drives, using a flashlight if necessary:

**CAUTION:**

**Possible component damage:** Make sure you follow the ESD procedure described in [“ESD-Protection Procedure” on page xxiii](#) for the next step.

5. Obtain the personality module from the bag taped to the power supply handle and insert it into its connector at the rear of the library. *The library will not initialize properly unless the personality module is installed.*

- A 20-cell version uses part 31363270x.
- A 40-cell version uses part 31363300x.

6. If your library is a 20-cell version, attach the cell barrier clip ([Figure 1-2 on page 1-19](#)) onto the next to the bottom cell of Column 1. This clip identifies the cells that you may use for your data cartridges.
7. Connect one end of the power cable into the rear of the library.
8. Connect the other end of the power cable into the wall socket.
9. Power-on the library and drives. The library will begin its initialization routine.
10. When initialization is complete, use the operator panel to configure the library and drives.

**Note:** Refer to the user’s guide for any field values that you do not understand.

11. When the configuration is complete, power-off the library and drives.
12. Connect the SCSI cables to the rear of the library.
13. Attach the HVD or LVD label to the SCSI cable connector.
14. Terminate the last drive in the string:
  - HVD uses terminator part 10187075.
  - LVD/SE uses terminator part 10148031.

**Note:** If your library includes an optional Fibre Channel router, attach cables according to the figures under [“Connecting Fiber and SCSI Cables” on page 1-16](#).

15. Power-on the library to activate the firmware.
16. Wait for the library to complete initialization.
17. Press the **MENU** button.

18. Press the **SELECT** button.

The > sign appears to the left of Door Operations. The DOOR MENU: Push Select to Prepare Library for Opening Door message appears.

19. Press the **SELECT** button.

**CAUTION:**

***Possible hand damage: Always wait for the operator panel to display the OK To Open Door message before opening the door. This ensures that the hand assembly is safely seated.***

20. Insert the key into the lock, and unlock and open the door.

21. Insert the labeled cartridges into the library.

Make sure that the cartridge hub is down and the volume label is facing the robot.

22. Close and lock the door, and remove the key.

The library will initialize and audit the cartridges.

23. Configure your tape management software at the console.

24. Place the library online.

25. Record your library configuration information in [Table 1-6 on page 1-30](#).

26. Make a copy of the table and give it to the customer. The customer will refer to it when making a service call or ordering features and upgrades.

## ■ Standard Installation Procedure

The procedure for the standard installation of the library takes you through each step of the installation process.

Check off the tasks in this list as you complete them:

1. **“Preparing for the Installation” on page 1-5**
2. **“Unpacking the Library” on page 1-5**
3. **“Inspecting the Library and Drives” on page 1-8**
4. **“Preparing the Installation Location” on page 1-8**
5. **“Positioning the Library” on page 1-9**
6. **“Installing the External Fibre Channel Router” on page 1-14**
7. **“Connecting the External SCSI Cables” on page 1-14**
8. **“Connecting Fiber and SCSI Cables” on page 1-16**
9. **“Attaching the Personality Module” on page 1-18**
10. **“Attaching the Cell Barrier Clip” on page 1-19**
11. **“Inserting the Cartridges” on page 1-20**
12. **“Installing the Drives” on page 1-26**
13. **“Powering-on the Library and Drives” on page 1-29**

## Preparing for the Installation

Read “Safety” on page xvii before beginning.

In general, for a successful installation you should be familiar with:

- SCSI principles (bus termination, terminating power, addressing)
- The SCSI cable plan for your installation
- The SCSI addresses (IDs) already in use by your system
- The SCSI IDs chosen for the devices to be installed (library and drives)
- Fibre Channel principles (termination, cabling, addressing) if your library includes an optional Fibre Channel router

## Unpacking the Library

**Note:** Save all the packing material in case you want to relocate or return the library in the future.

Become familiar with the components in [Figure 1-1 on page 1-6](#), and:

1. Cut any packing tape, bands, and seals, and remove the outer container.
2. Remove the container locks.
3. Remove the container cap.
4. Remove the accessory container.
5. Remove the sleeve.
6. Remove the top cushion.
7. Remove the plastic bag.
8. Remove the front and rear rail of the bottom cushion. *Do not remove the library from the pallet.*
9. Obtain the door key, part 419712101, from the accessory container, and unlock and open the door.

Figure 1-1. Unpacking the Library (L201\_158)

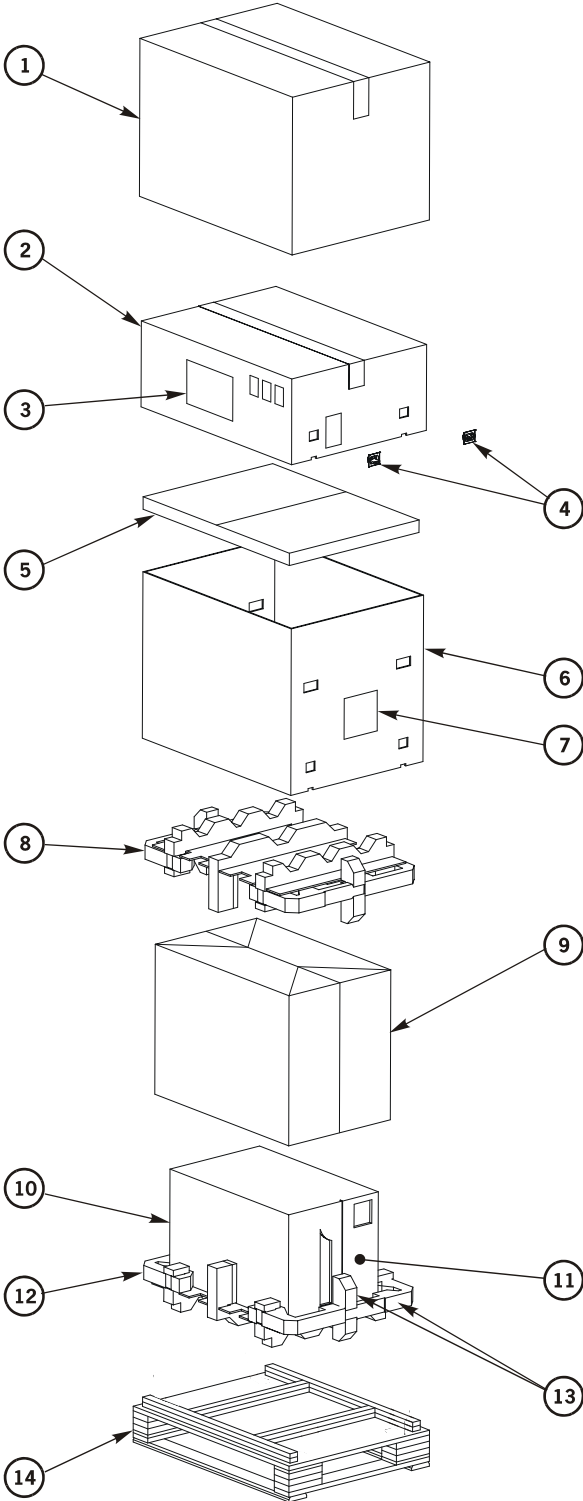

L201\_158



**Figure 1-1. Unpacking the Library (L201\_158)**

---

1. Outer Container	7. Bar code label, used for repacking
2. Container cap	8. Top cushion
3. Logo label, used for repacking	9. Plastic bag
4. Container locks (Hold so the protruding part is on top. Squeeze the ears and lift the locks to secure them into the openings.)	10. Library
5. Accessory container	11. Internal bracing items
6. Sleeve	12. Bottom cushion
	13. Front and rear rail
	14. Pallet

---

10. Cut the tie wraps and remove the packing cushion from the Z shaft.

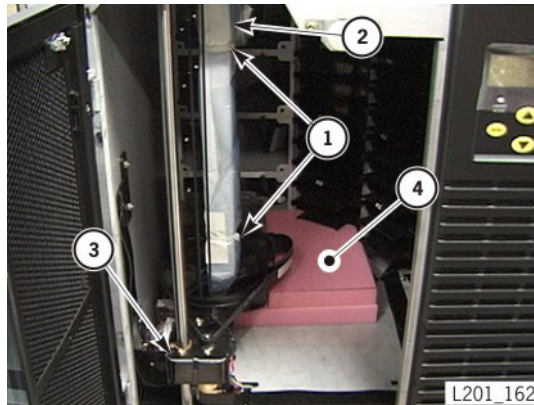

1. Tie Wraps
2. Packing cushion around the rear Z shaft
3. Z carriage
4. Hand foam

11. Carefully raise the Z carriage and remove the foam securing the hand assembly.

## Inspecting the Library and Drives

Visually inspect the library and drives, using a flashlight if necessary:

1. Check the library's exterior and interior for any obvious physical damage or loose parts.
2. Make sure that the cables and accessories you require are present. Refer to your shipping bill. Some items might be shipped in a separate package.
  - \_\_\_ SCSI cables
  - \_\_\_ SCSI terminators
  - \_\_\_ SCSI adapters
  - \_\_\_ Fibre Channel cables
  - \_\_\_ AC power cable
  - \_\_\_ Cartridges and labels
  - \_\_\_ Personality module (in a bag taped to the power supply handle)
3. Report any damaged, missing, or incorrect items to your sales representative.

## Preparing the Installation Location

Prepare the installation location:

1. Make sure that the location is clean, dry, level, and adequately ventilated.
2. Allow sufficient space to service the library from the front, right side, and rear. Each of these areas should have a service clearance of 610 mm (2 ft).
3. Make sure that the AC power outlet is near the library and is easily accessible to the library's power cable.
4. If you are installing the library in a 483-mm (19-in.) standard-width rack, you must have either brackets or a tray measuring at least 711 mm (28 in.) deep. Make sure that the brackets or tray is installed within the rack before you install the library.

See [Figure 2-7 on page 2-9](#) or [Figure 2-8 on page 2-10](#) to make sure your installation area meets the required dimensions and weight.

## Positioning the Library

The library can be ordered for either desktop or rack installation.

### Desktop Installation

**WARNING:**

***Possible personal injury:*** Check the path to the intended location and clear it of obstructions before you move the library. Use at least two people and a mechanical device to lift and position the library. The library weighs 44.45 kg (98 lb) plus the weight of the drives. Depending upon the drive type, each drive weighs between 5.0 kg (11 lb) and 5.5 kg (12 lb).

**ADVERTENCIA:**

***Posibilidad de lesiones físicas:*** Antes de mover la biblioteca, verifique el trayecto hasta la ubicación de instalación prevista y retire cualquier obstáculo. Para levantar la biblioteca y colocarla en su posición se requieren como mínimo dos personas. La biblioteca pesa 44,45 kg (98 lb), a lo que hay que añadir el peso de las unidades. En función del tipo de unidad, cada unidad pesa entre 5,0 kg (11 lb) y 5,5 kg (12 lb).

**CAUTION:**

***Equipment damage:*** Do not grip the library by the power supply handles or by the fans.

To install the desktop library:

1. Place the library on any sturdy desk or table within cabling distance to your client-server computer.
2. Install the drive trays, if they were not shipped with the library.  
See [“Installing the Drives” on page 1-26](#).

### Rack Installation

Use a standard 483-mm (19-in.) rack with 10 rack units of space to accommodate the library, which sits on brackets or a tray provided by the customer. The library is secured to the rack with screws and nut clips to prevent anyone from pulling the library off the rack.

The rack can have a rear door. The door must extend at least 102 mm (4 in.) beyond the library to allow proper air flow for the library’s cooling fans and for cable routing. The maximum rack air ambient temperature is 40°C (104°F).

To allow easy access to the CAP and operator panel, the rack should not have a front door. If you install a front door, make sure that the door provides proper ventilation.

The library uses the power cable's ground point for its earth-ground connection. All electrical connections, either directly to the wall or to a power strip in the rack, must be properly grounded. Consider proper electrical circuit and power strip overload protection.

**Note:** The rack can be ordered from Sun StorageTek or from another vendor. The StorageTek conversion bill number for the black rack is YXL20/40/80-SHELF.

To install the library in a rack:

1. Install the brackets or tray onto the rack if not previously done. The tray must be at least 749.3 mm (29.5 in.) deep.

**WARNING:**

***Possible personal injury:*** Check the path to the intended location and clear it of obstructions before you move the library. Use at least two people and a mechanical device to lift and position the library. The library weighs 44.45 kg (98 lb) plus the weight of the drives. Depending upon the drive type, each drive weighs between 5.0 kg (11 lb) and 5.5 kg (12 lb).

**ADVERTENCIA:**

***Posibilidad de lesiones físicas:*** Antes de mover la biblioteca, verifique el trayecto hasta la ubicación de instalación prevista y retire cualquier obstáculo. Para levantar la biblioteca y colocarla en su posición se requieren como mínimo dos personas. La biblioteca pesa 44,45 kg (98 lb), a lo que hay que añadir el peso de las unidades. En función del tipo de unidad, cada unidad pesa entre 5,0 kg (11 lb) y 5,5 kg (12 lb).

**WARNING:**

***Tip hazard:*** When installing the library, be careful to keep the rack from tipping over.

**ADVERTENCIA:**

***Peligro de vuelco.*** Al instalar la biblioteca, tenga cuidado de que el bastidor no se vuelque.

**CAUTION:**

***Equipment damage:*** Do not grip the library by the power supply handles or by the fans.

2. Slide the library onto the previously installed supporting brackets or tray.

**Note:** You must remove the front door and decorative cover over the operator panel to access the holes in the library flanges.

3. Insert the key into the lock on the door, and unlock and open the door.
4. Hold the door *firmly* with your left hand and remove the bottom hinge pin, then the top hinge pin.

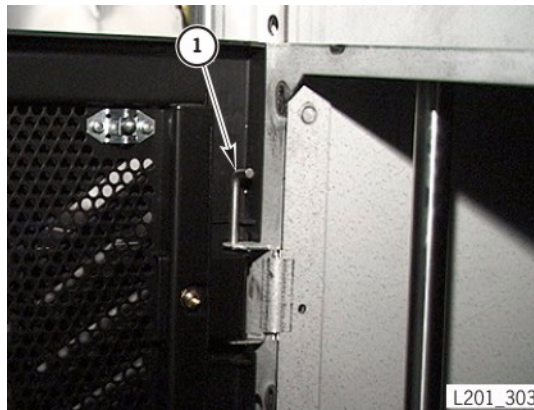

1. Hinge pin (2)

5. Set the door aside.
6. Remove the right decorative cover over the operator panel by grasping the *top* of the cover and *gently* pulling it away from the operator panel.

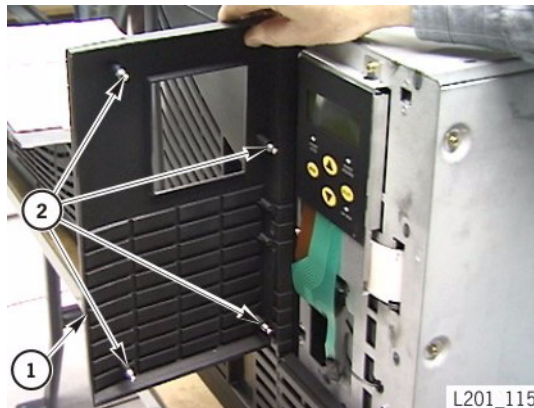

1. Cover  
2. Cover snap pins

7. Measure and note the distances from the bottom of the library flanges to the mounting holes near the four corners of the front of the library frame. Note that the distances for the left and right flange hole spaces are different.
8. Using these distances, install the four nut clips into the rack so that their locations match the hole locations from the previous step.
9. Secure the library to the rack with four screws through the rack to the screw nut clips on the rear of the rack.

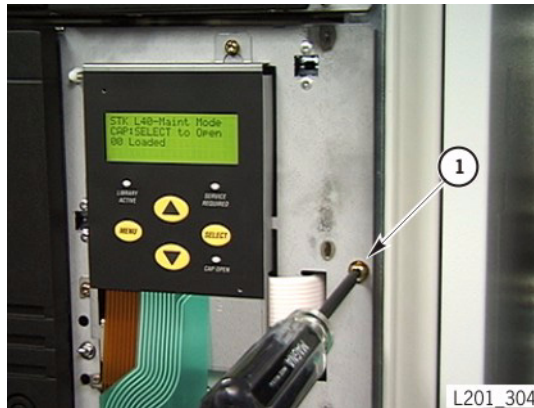

1. Screw (4)

10. Attach the cover over the operator panel.

11. Attach the door with the two hinge pins, inserting the top pin first.

## Choosing SCSI HVD or LVD

Your library interface is hardware configured as either high voltage differential (HVD) or low voltage differential (LVD). The HVD interface allows longer cable lengths, but throughput is slower than LVD. The LVD interface restricts cable lengths, but provides faster throughput.

### **CAUTION:**

**Potential equipment damage: Do not mix LVD and HVD operation on the same bus.**

## SCSI Cable Restrictions

The library and drives accept *only* SCSI Type-3 connectors. If you use SCSI Type-1 or -2 connectors, you must use a SCSI Type-1- or SCSI Type-2-to-SCSI Type-3 adapter.

**Note:** If you are connecting the library or drives to an LVD SCSI bus, the cable can be no longer than 12 m (39.4 ft).

Each interface requires a unique terminator.

The following table lists restrictions for SCSI connections.

**Table 1-1. SCSI Cable Length Restrictions**

Application	Length Restriction
Single-ended	Stub length: 102 mm (4 in.) 5 to 10 MB/s data transfer rate: 3 m (10 ft) 1 to 5 MB/s data transfer rate: 6 m (20 ft)
High voltage differential	Stub length: 203 mm (8 in.) 1 to 40 MB/s data transfer rate: 25 m (82 ft)
Low voltage differential	Stub length: 102 mm (4 in.) 1 to 80 MB/s data transfer rate: 12 m (39.37 ft)

## Host Bus Adapter Requirements

The host bus adapter (HBA) in your server must match the library and drive's SCSI bus type. If the interface to the library is HVD, the server must contain an HVD-compatible HBA; if the interface to the library is LVD, the server must contain an LVD-compatible HBA.

## SCSI Device/Bus Type Issues

The following table lists the possible issues you could encounter if you mix interfaces on the same bus.

**Table 1-2. SCSI Device/Bus Types: Issues**

If you plug a . . .	Into . . .	The result is . . .
Single-ended device	Single-ended bus	Proper connection
	LVD bus	Single-ended mode
	HVD bus	Operation disabled
Low voltage differential device	Single-ended bus	Single-ended mode
	LVD bus	Proper connection
	HVD	<i>Potential damage</i> /disabled device
High voltage differential device	Single-ended bus	Disabled device
	LVD bus	<i>Potential damage</i> /disabled device
	HVD bus	Proper connection

## Installing the External Fibre Channel Router

To install the optional external Fibre Channel router, refer to *StorageNet 3300 Fibre Channel Router User Manual*, Chapter 2.

If installing an external fibre channel router to replace an internal fibre channel router card, remove the internal fibre channel router card. Refer to the *L40 Tape Library Service Manual*, PN 96026.

## Connecting the External SCSI Cables

**Note:** You can connect the library and drives to the same bus (on bus) or to separate buses (off bus). However, for the on bus configuration, a bus reset will affect all devices on the bus. Library availability can be improved by ensuring that the library is on a separate bus from the drives.

You should be familiar with SCSI principles to correctly cable your system.

The library supports the use of:

- Digital linear tape (DLT) 7000E/8000 drives on an HVD interface
- DLT 8000 drives on an LVD interface
- Ultrium linear tape open (LTO) drives on an LVD interface (native) or on an HVD interface (with an optional converter card that is on the drive tray assembly when ordered as HVD from Storage Technology Corporation)
- DLT1 drives on an LVD interface (native) or on an HVD interface (with optional converter card)

To attach SCSI cables:

1. Attach a SCSI daisy-chain cable to one rear SCSI port on the drive. These cables should be at least 300 mm (11.81 in.) if connecting from the LLC card to the top drive slot, or 600 mm (1.97 ft) if connecting from the LLC card to the bottom drive slot. If you have an internal Fibre Channel router installed, use the 600 mm (1.97 ft.) cable to reach from the LLC card to the drive slots.
2. Connect the client-server cable to the library.

**Note:** Make sure you properly set the SCSI IDs for the drives and library, or you might stop activity on the SCSI bus. You will set the IDs when you configure the library and drives.

3. Install the provided terminator on the remaining SCSI port of the lowest drive that is installed, and on the client server computer, if required:
  - HVD uses terminator part 10187075.
  - LVD/SE uses terminator part 10148031.



You can vary this cabling arrangement depending on how your system is configured. For example, you can attach one of the drives to a different bus, in which case that drive would have its own SCSI terminator.

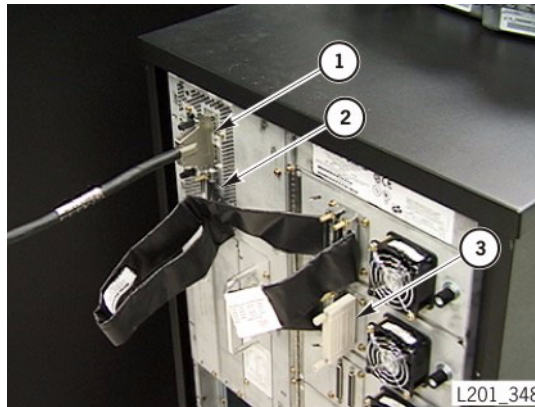

1. Client-server cable
2. SCSI cable
3. SCSI terminator

## Connecting Fiber and SCSI Cables

For libraries with an optional Fibre Channel router, follow the cable routing shown in following two figures. The first figure shows cable routing for the library, four drives, and internal router.

The second figure shows a detail of cable routing to the SN3300 external router.

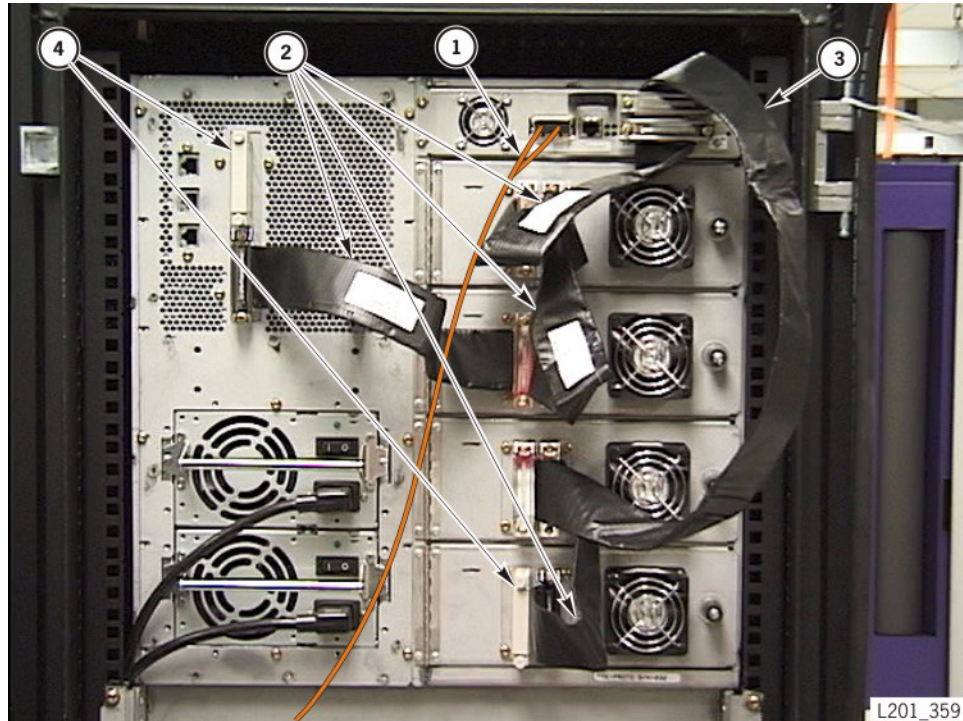

1. Fiber cables to/from host
2. Four 300 mm (11.81 in.) LVD SCSI cables
3. One 600 mm (1.97 ft) LVD SCSI cable
4. Two SCSI terminators

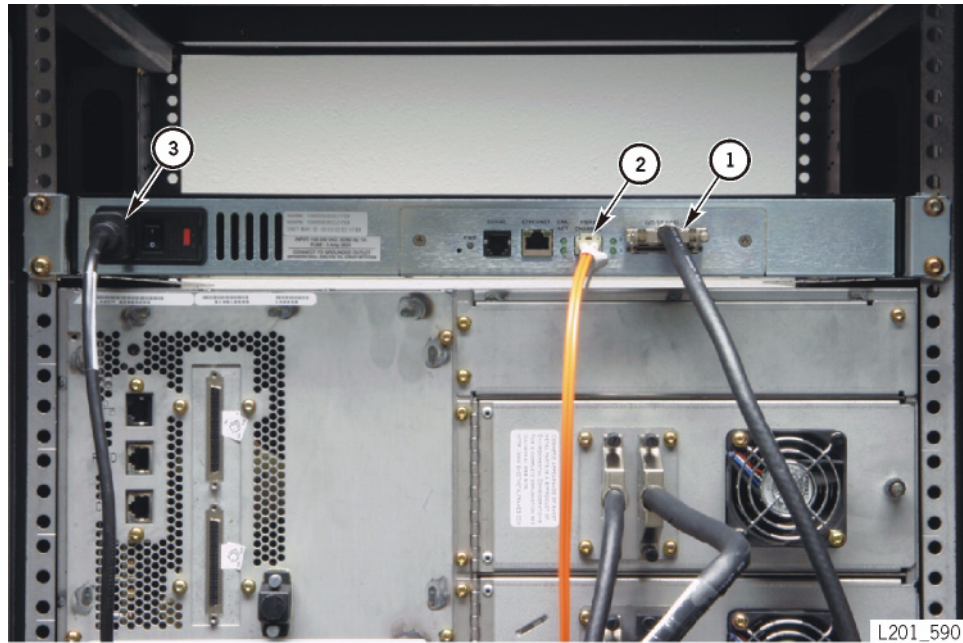

1. Fiber cables to/from host
2. One of four 300 mm (11.81 in.) LVD SCSI cables
3. Power cable

## Attaching the Personality Module

The personality module is a connector that stores the library cell capacity information. The module stores a capacity of either 20 or 40 cells. The library does not operate properly unless an authorized module is attached to the rear of the EM.

*Attach the module before powering-on the library for proper initialization. Only remove the module when installing an upgrade conversion bill or replacing the library.*

### **CAUTION:**

**Possible component damage:** Make sure you follow the ESD procedure described in [“ESD-Protection Procedure” on page xxiii](#) before connecting the personality module.

The personality module is in a bag taped to the power supply handle. Remove the personality module and attach it to its connector:

- A 20-cell version uses part 31363270x.
- A 40-cell version uses part 31363300x.

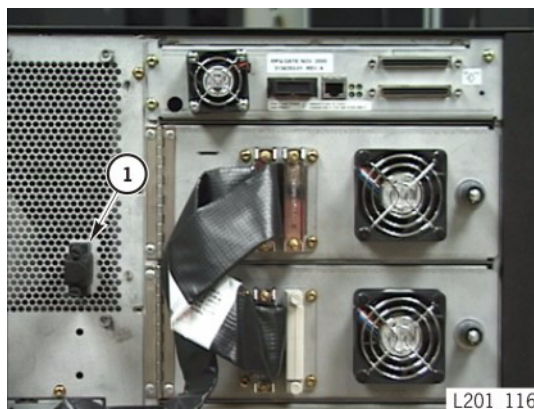

1. Personality module

# Attaching the Cell Barrier Clip

If your library is a 20-cell version, the tape management software only recognizes the data cells that are in Column 0 and the top nine cells of Column 1. To remind the operator to not place data cartridges into the other cells, attach the cell barrier clip, as shown in the following figure.

Use the PERS MODULE Menu on the operator panel to determine your library's cell capacity.

Figure 1-2. Attaching the Cell Barrier Clip (L201\_124)

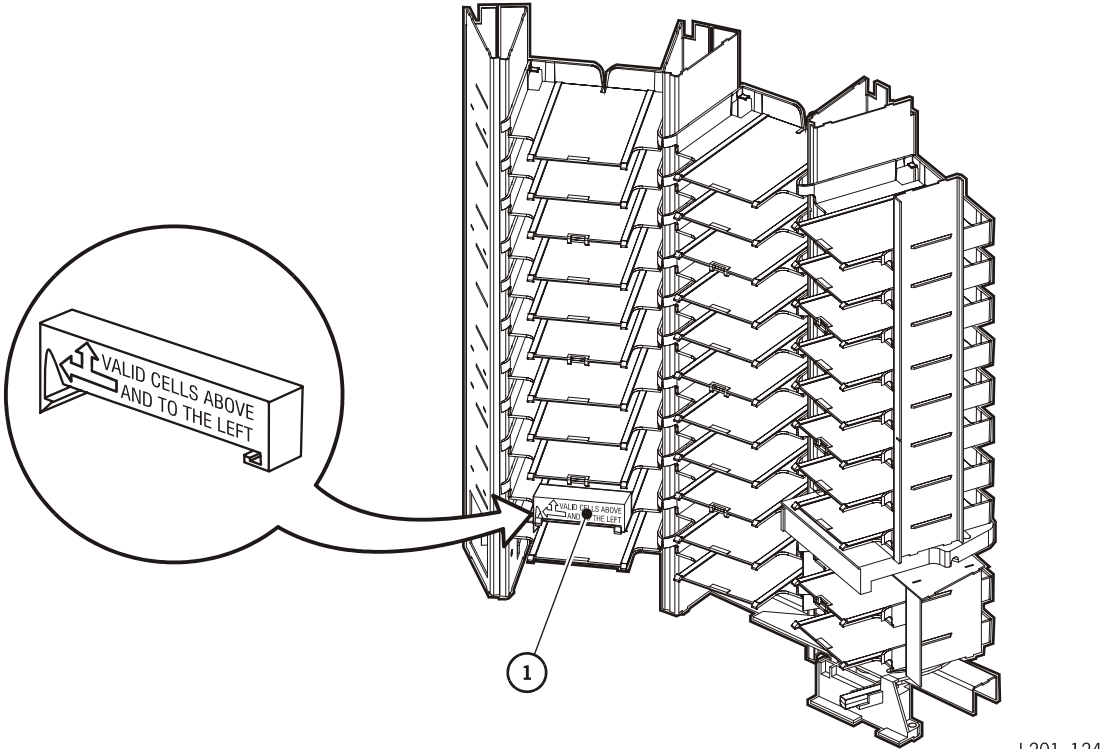

1. Cell barrier clip for 20-cell version

## Inserting the Cartridges

Make sure you refer to “ESD Precautions” on page xxii before proceeding.

Depending on the version and configuration of your library, some storage cells cannot be used. Read the legend on the page following [Figure 1-3 on page 1-21](#).

**CAUTION:**

**Inserting the cartridges correctly is critical for library operation. If you do not orient the cartridges correctly or do not insert them all the way into the storage cells, the library might fail, and the operator panel might display an error message. Make sure you insert the cartridge *inside* the black array, not above or beneath it. [Figure 1-4 on page 1-22](#) shows the correct way to insert cartridges into storage cells.**

**Do not place a white cartridge into cell 1022d (see [Figure 1-3 on page 1-21](#)), or you will cause an initialization failure.**

Check the cartridges to make sure that they are correctly labeled, as described in the user’s guide.

The media check feature, if enabled, ensures that there are no unreadable, unlabeled, or improperly placed cartridges. If the robot cannot grab one of these cartridges, the library status will be “not ready.”

**Note:** You do not have to insert a cartridge into every storage cell. The library automatically audits cartridges and empty cells as part of its initialization routine.

Insert as many cartridges into the library as you want and as your configuration allows, making sure you seat them all the way into the storage cells.

Figure 1-3. Determining the Valid Storage Cells (L201\_038)

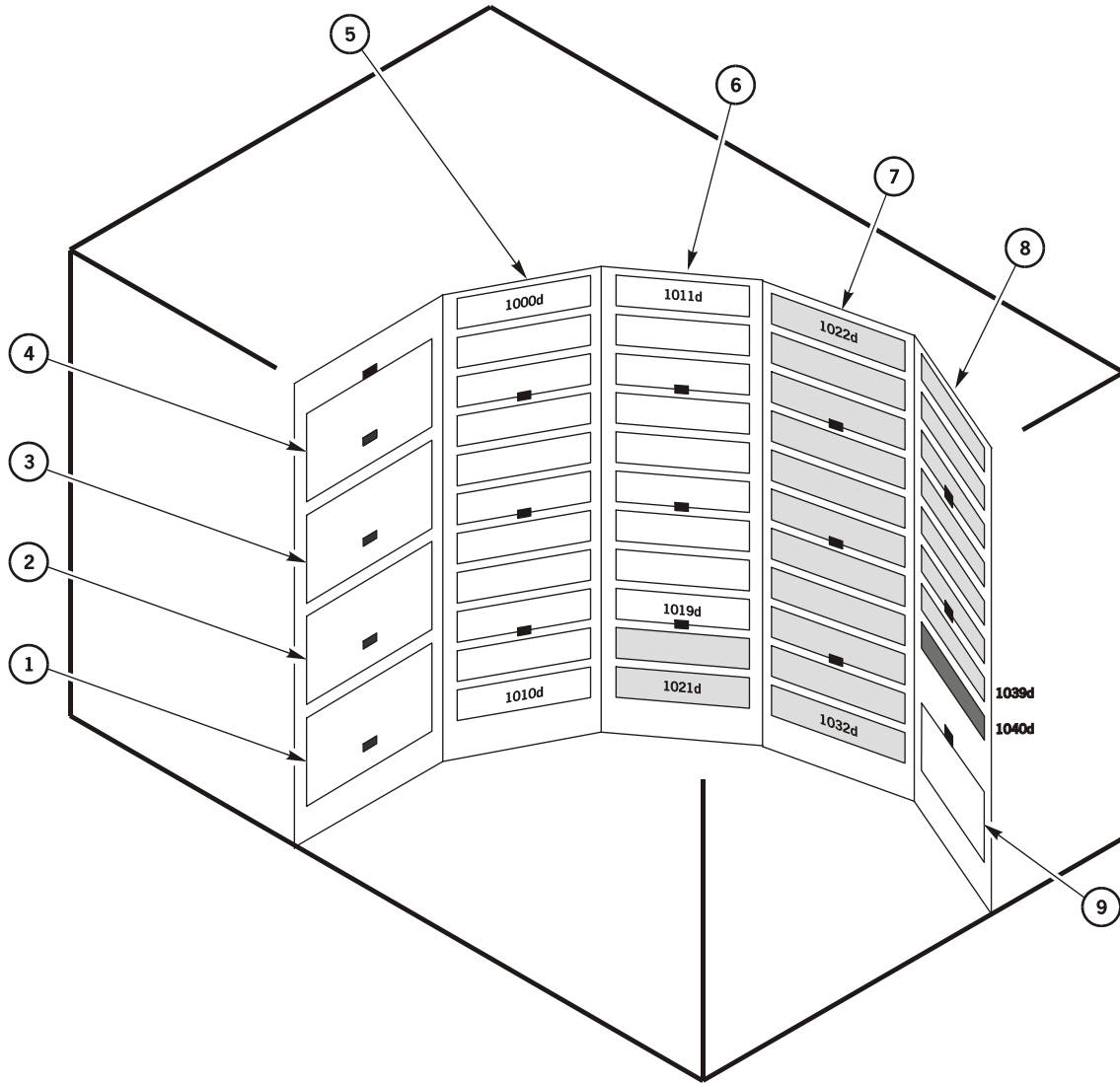

L201\_038

- |                 |                 |                    |
|-----------------|-----------------|--------------------|
| 1. Drive Slot 3 | 4. Drive Slot 0 | 3. Column 2        |
| 2. Drive Slot 2 | 1. Column 0     | 4. Column 3        |
| 3. Drive Slot 1 | 2. Column 1     | 5. CAP (two cells) |

**Note:** In a 40-cell capacity library, if Auto Clean is not enabled, the cleaning cartridge cell can be used for a data cartridge, for a total of 41 data cells.

**Legend:**

- Use Columns 0 and 1 white cells for the 20-cell configuration.
- Use Columns 0 and 1 white cells and Columns 2 and 3 gray cells for the 40-cell configuration.
- Use the black cell above the CAP for a cleaning cartridge if Auto Clean is enabled.
- The small, black rectangles are targets.

Figure 1-4. Inserting the Cartridges (L201\_284)

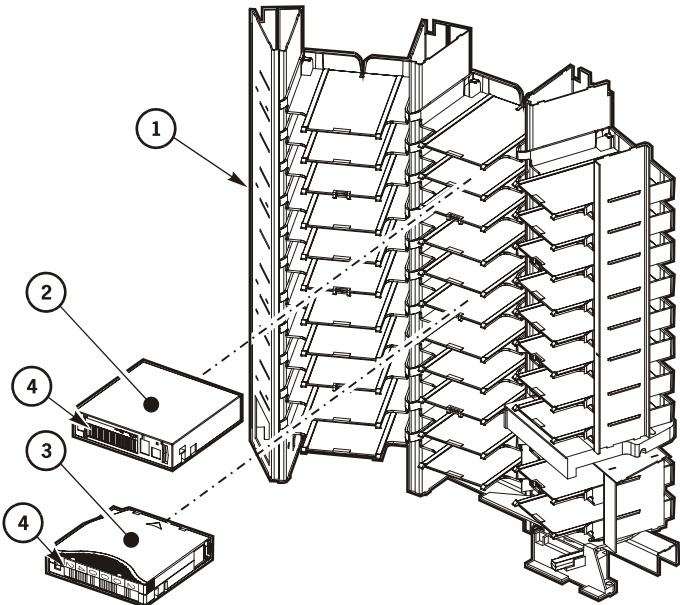

L201\_284

- 1. Storage Cells
- 2. DLT cartridge
- 3. Ultrium cartridge
- 4. Volume number



## Drive Compatibility Issues

Refer to your drive publications and the vendor Web sites for a detailed discussion of drives and cartridges.

The library supports the following drives:

- Ultrium Linear Tape-Open (LTO) drives

LTO technology was developed by IBM, Hewlett-Packard, and Seagate to provide a clear and viable choice in an increasingly complex array of tape storage options. LTO is an “open format” technology, which means that users will have multiple sources of product and media. The open nature of LTO technology also provides a means of enabling compatibility among different vendor’s offerings.

- Hewlett-Packard’s LTO 1, LTO 2, and LTO 3
- IBM’s LTO 1, LTO 2, and LTO 3
- Quantum’s (Certance) LTO 2 and LTO 3
- Seagate LTO 1 and LTO 2

- Digital Linear Tape (DLT) drives:

- Quantum Corporation’s DLT 7000E, DLT 8000, and Super DLT 220, 320 and 600
- Benchmark Storage Innovations, Inc’s DLT1

You may mix drive types within a library, but please observe the following cautions and tables:

### CAUTION:

***Possible data corruption: Do not mix DLT 7000 and DLT 8000 drives in the same library. If a DLT 7000 cartridge is inserted into a DLT 8000 drive, the tape can be read and written on in 7000 mode. If a DLT 8000 cartridge is inserted into a DLT 7000 drive and a read command is issued, the drive will indicate Medium Error/Calibration Error (03/8000). If a write command is issued at load point, as with most drives, the drive will write over any data present.***

### CAUTION:

***Data loss: Do not mount SDLT 320-formatted cartridges into SDLT 220 drives. An SDLT 220 drive will overwrite the 320 data. To avoid this, carefully manage the locations of the cartridges within your library, and designate the correct drive type for your read/write operations.***

Do *not* mix LVD and HVD operations on the same bus.

DLT1 drives use only DLTtape IV cartridges, and can read—but not write to—DLTtape IV cartridges formatted by DLT 4000 drives.

DLT1 drives use their own cleaning cartridge, part 100099401. Do *not* use this cartridge in DLT drives.

**Table 1-3. LTO Drive Backward Readability**

	LTO Gen 2 Drive	LTO Gen 3 Drive
LTO 1 media	Read and write	Read only
LTO 2 media	Read and write	Read and write
LTO 3 media	No action	Read and write

**Table 1-4. SCSI Device/Bus Types: Issues**

If you plug a . . .	Into . . .	The result is . . .
Single-ended device	Single-ended bus	Proper connection
	LVD bus	Single-ended mode
	HVD bus	Operation disabled
Low voltage differential device	Single-ended bus	Single-ended mode
	LVD bus	Proper connection
	HVD	<i>Potential damage</i> /disabled device
High voltage differential device	Single-ended bus	Disabled device
	LVD bus	<i>Potential damage</i> /disabled device
	HVD bus	Proper connection

The drive interfaces are SCSI high voltage differential (HVD) or SCSI low voltage differential (LVD). The HVD interface allows longer cable lengths, but throughput is slower than with the LVD interface. The LVD interface restricts cable lengths, but provides faster throughput.

The following table shows the types of drives and the interfaces that are supported.

**Table 1-5. Compatible Drives and Interfaces**

Drive Name	Sustained Native Transfer Rate	Interface	
		HVD <sup>1</sup>	LVD <sup>2</sup>
DLT 8000	6.0 MB/s	Ultra-2 SCSI HVD Fast 40	Ultra-2 SCSI LVD 80MB/s, SE 40MB/s
SDLT 220	11 MB/s	Ultra-2 SCSI HVD Fast 40	Ultra-2 SCSI LVD 80MB/s, SE 40MB/s
SDLT 320	16 MB/s	Ultra-2 SCSI HVD Fast 40	Ultra-2 SCSI LVD 80MB/s, SE 40MB/s
SDLT 600	36 MB/s	N/A	Ultra-3 SCSI LVD 160 MB/s, SE 40 MB/s
Seagate/Certance Ultrium 1 LTO <sup>5</sup>	16 MB/s	Ultra-2 SCSI HVD Fast 40	Ultra-2 SCSI LVD 80 MB/s, SE 40 MB/s
Seagate/Certance Ultrium 2 LTO <sup>5</sup>	34 MB/s	N/A	Ultra-2 SCSI LVD 80 MB/s
Seagate/Certance Ultrium 3 LTO <sup>5</sup>	68 MB/s	N/A	Ultra-3 SCSI Ultra-160 LVD 160MB/s
IBM Ultrium 1 LTO	15 MB/s	Ultra-2 SCSI HVD Fast 40	Ultra-2 SCSI LVD 80 MB/s
IBM Ultrium 2 LTO	35 MB/s	N/A	Ultra-3 SCSI(Ultra-160) LVD 160MB/s
IBM Ultrium 3 LTO	80 MB/s	N/A	Ultra-3 SCSI(Ultra-160) LVD 160MB/s
HP Ultrium 1 LTO	15 MB/s	Ultra-2 SCSI HVD Fast 40	Ultra-2 SCSI LVD 80 MB/s, SE 40MB/s
HP Ultrium 2 LTO	30 MB/s	N/A	Ultra-3 SCSI Ultra-160 LVD 160MB/s
HP Ultrium 3 LTO	80 MB/s	N/A	Ultra-4 SCSI Ultra-320 LVD 160MB/s

1. The maximum burst speed of data transfer for the HVD interface is at 40 MB/s
2. The maximum burst speed of data transfer for the LVD interface varies depending upon the type of SCSI interface.
3. Certance is owned by Quantum Corporation.

## Installing the Drives

See [“Drive Compatibility Issues”](#) on page 1-23.

**If you are installing an SDLT 600 drive, make sure that Field Bill 102181 was installed. The field bill replaces the internal fan finger guard with a perforated steel plate to comply with emissions standards.**

Use the information in the following paragraphs if you ordered a library that did not have the drives already installed, or if you want to add more drives to your library.

**Note:** Because the drive is part of the drive tray assembly, you will actually be installing the assembly.

You should always add drives by starting at the empty slot nearest the top and working downward. The drive numbers are assigned from top (0) to bottom (3). By adding drives in this order, the client software will correctly reflect the drives previously installed.

If you already have some drives installed, observe these precautions before beginning:

### **CAUTION:**

***Possible data loss or system problem: If you must disconnect the external SCSI cables, make sure that you stop all processes attached to this system.***

- If the drives are daisy-chained, stop all data processing on the channel to which the drives are connected before disconnecting the drives.
- Make sure that there is no activity on the SCSI bus before disconnecting the external SCSI cables. Stop all processes on the client-server computer.
- Make sure that all signals are terminated at each end of the SCSI bus.
- Do not mix single-ended and differential terminators.

### **WARNING:**

***Lifting hazard: Depending upon the drive type, each drive and tray weighs between 5.0 kg (11 lb) and 5.8 kg (12.7 lb). Make sure you follow the lifting instructions in [“Lifting Techniques”](#) on page xviii.***

### **ADVERTENCIA:**

***Riesgo al levantar: En función del tipo de unidad, cada unidad y bandeja pesa entre 5,0 kg (11 lb) y 5,8 kg (12,7 lb). Asegúrese de seguir las instrucciones de la sección [“Técnicas de levantamiento de objetos”](#) en la página xxvi.***

**CAUTION:**

**Possible component damage:** Do not use a screwdriver for the drive door latch knob or drive tray latch.

1. At the rear of the library, turn the drive door latch knob to your left to open the drive door.

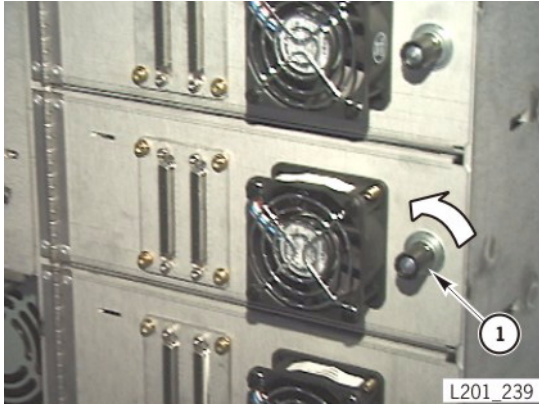

1. Knob

**CAUTION:**

**Load/unload problems:** The drive tray latch must be fully loosened (disengaged) before you slide the tray into the slot. If the latch arm contacts part of the library frame as it is being tightened, it cannot be rotated to its fully locked position, and the tray will not be firmly locked into the drive slot. This can cause alignment problems and the camera can have problems reading the target.

2. Holding the drive tray assembly as shown in the figure below, turn the drive tray latch knob all the way to your right so that it is in its fully disengaged position.

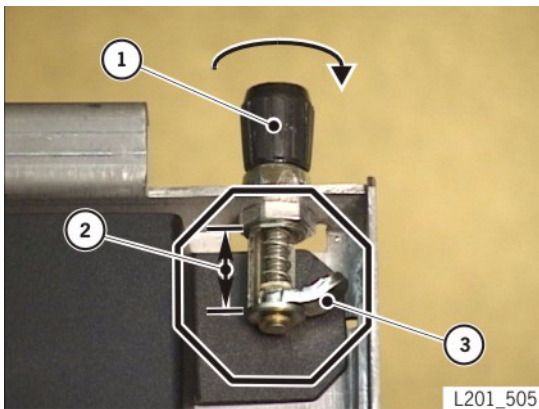

1. Knob
2. Range
3. Latch arm (shown disengaged)

- 
- Slide the drive tray assembly into the desired slot.
- 

**CAUTION:**

**Possible component damage: Do not use a screwdriver to tighten the drive tray latch knob.**

- Turn the knob all the way to the right to engage the latch and clamp it firmly into the frame.
  - Pull back on the tray to make sure the tray is securely latched. It should not move.
- 
- Connect the drive SCSI connector, P903, to the drive.
  - Connect the drive power cable, P904A/B, to the library.
  - Connect the serial interface connector, P6A/B, to the library.

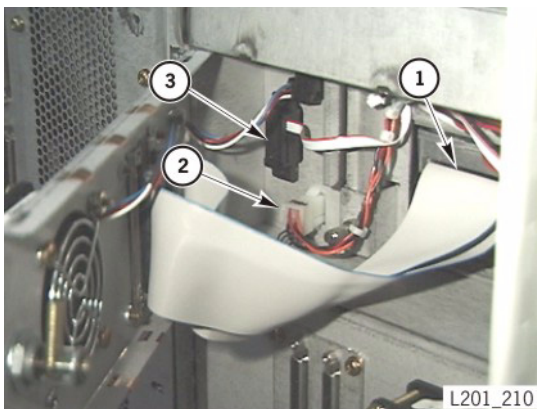

- P903
- P904A/B
- P6A/B

**CAUTION:**

**Possible equipment damage: Make sure the SCSI cable does not block the fan before you close the drive door.**

**Possible cable damage: Make sure you move the SCSI cable out of the way before you close the drive door.**

**Possible component damage: Do not use a screwdriver to tighten the drive door latch knob.**

- Close the drive door and secure it by turning the drive door latch knob to your right.
  - Refer to your user's guide to configure the drives.
-

## ■ Powering-on the Library and Drives

To power-on the library and drives:

**CAUTION:**

***Possible equipment damage:* Make sure the power-on/off switch is set to “O” before performing Step 1.**

1. Close and lock the front door.
2. Attach the power cable to the power receptacle at the rear of the library and plug the cable into an electrical outlet.
3. Press the power switch to the “|” position.

The operator status display shows the `Init in Progress:` message. When initialization is complete, the status display shows the state of the library.

4. Use the library operator panel to configure the library and drives.

**Note:** Refer to the user’s guide for any field values that you do not understand.

**Note:** You must fully configure the library *before* you configure the tape management software.

## ■ Recording the Configuration Information

Record your library configuration in the following table. Then make a copy of the table and give it to the customer. The customer will refer to it when making a service call or ordering features and upgrades.

**Table 1-6. L40 Tape Library Configuration Information**

Library Serial Number _____
Library Warranty Number _____
Version: 20 cells <input type="checkbox"/> 32 cells <input type="checkbox"/> 40 cells <input type="checkbox"/>
Library Code Version _____
Library SCSI ID _____
Number of Drives Installed _____
Drive 0 Serial Number _____
Drive 0 Warranty Number _____
Drive 0 SCSI ID _____
Drive Type _____
On Bus <input type="checkbox"/> Off Bus <input type="checkbox"/>
Drive 1 Serial Number _____
Drive 1 Warranty Number _____
Drive 1 SCSI ID _____
Drive Type _____
On Bus <input type="checkbox"/> Off Bus <input type="checkbox"/>
Drive 2 Serial Number _____
Drive 2 Warranty Number _____
Drive 2 SCSI ID _____
Drive Type _____
On Bus <input type="checkbox"/> Off Bus <input type="checkbox"/>
Drive 3 Serial Number _____
Drive 3 Warranty Number _____
Drive 3 SCSI ID _____
Drive Type _____
On Bus <input type="checkbox"/> Off Bus <input type="checkbox"/>
Fast Load: Off <input type="checkbox"/> On <input type="checkbox"/>
Auto Clean: Off <input type="checkbox"/> On <input type="checkbox"/>
Network: Library Name _____
IP Address _____ Subnet Mask _____ Network
Gateway _____
Hardware Monitor _____
Warning Temperature _____
Shutdown Temperature _____



# Locations, Specifications, and Cables

## 2

This chapter identifies library components, drive label locations, specifications, and external cable part numbers.

### ■ Locations

Use the following figures to become familiar with the library components and drive label locations.

Figure 2-1. Front View of Components (L201\_061)

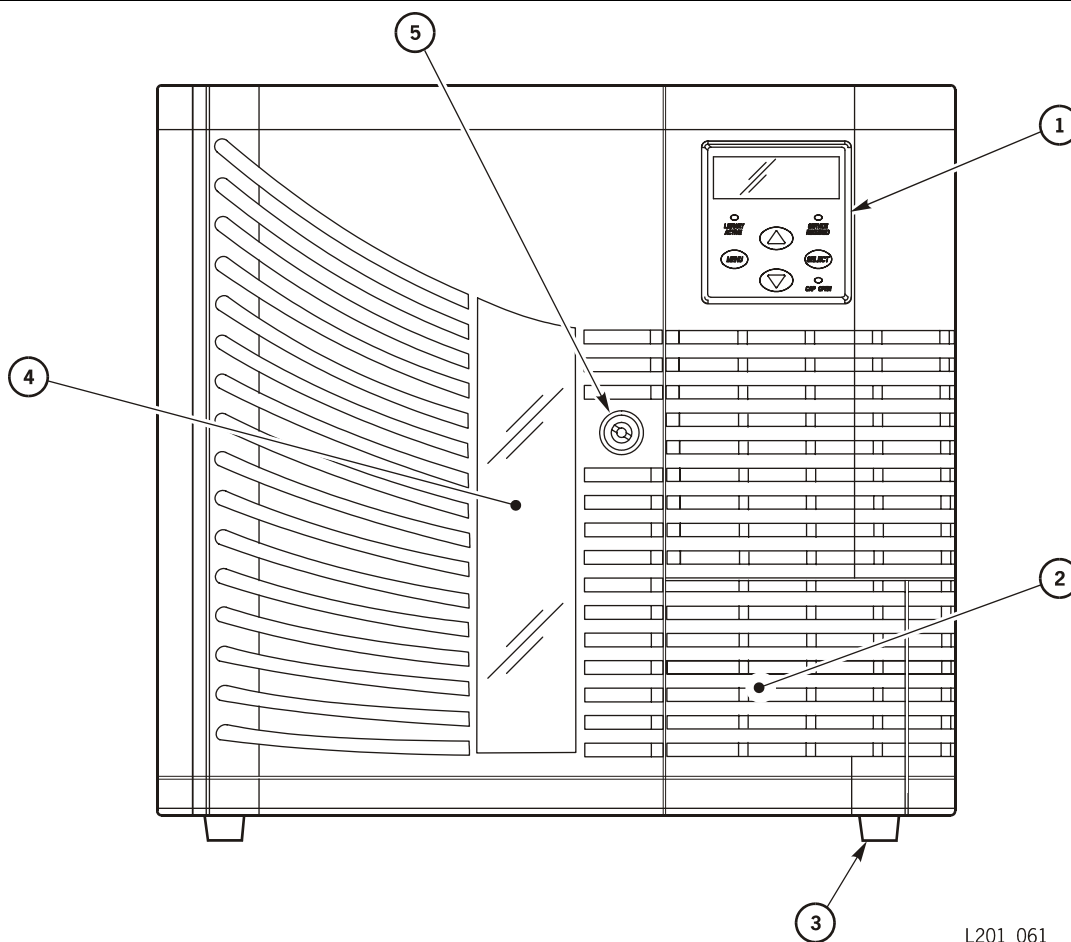

L201\_061

**Figure 2-1. Front View of Components (L201\_061)**

- |  |                   |
|--|-------------------|
| 1. Operator panel (including status display) | 4. Viewing window |
| 2. Cartridge access port (CAP)               | 5. Door lock      |
| 3. Elastomer feet for desktop version        |                   |

**Figure 2-2. Rear View of Components (L201\_062)**

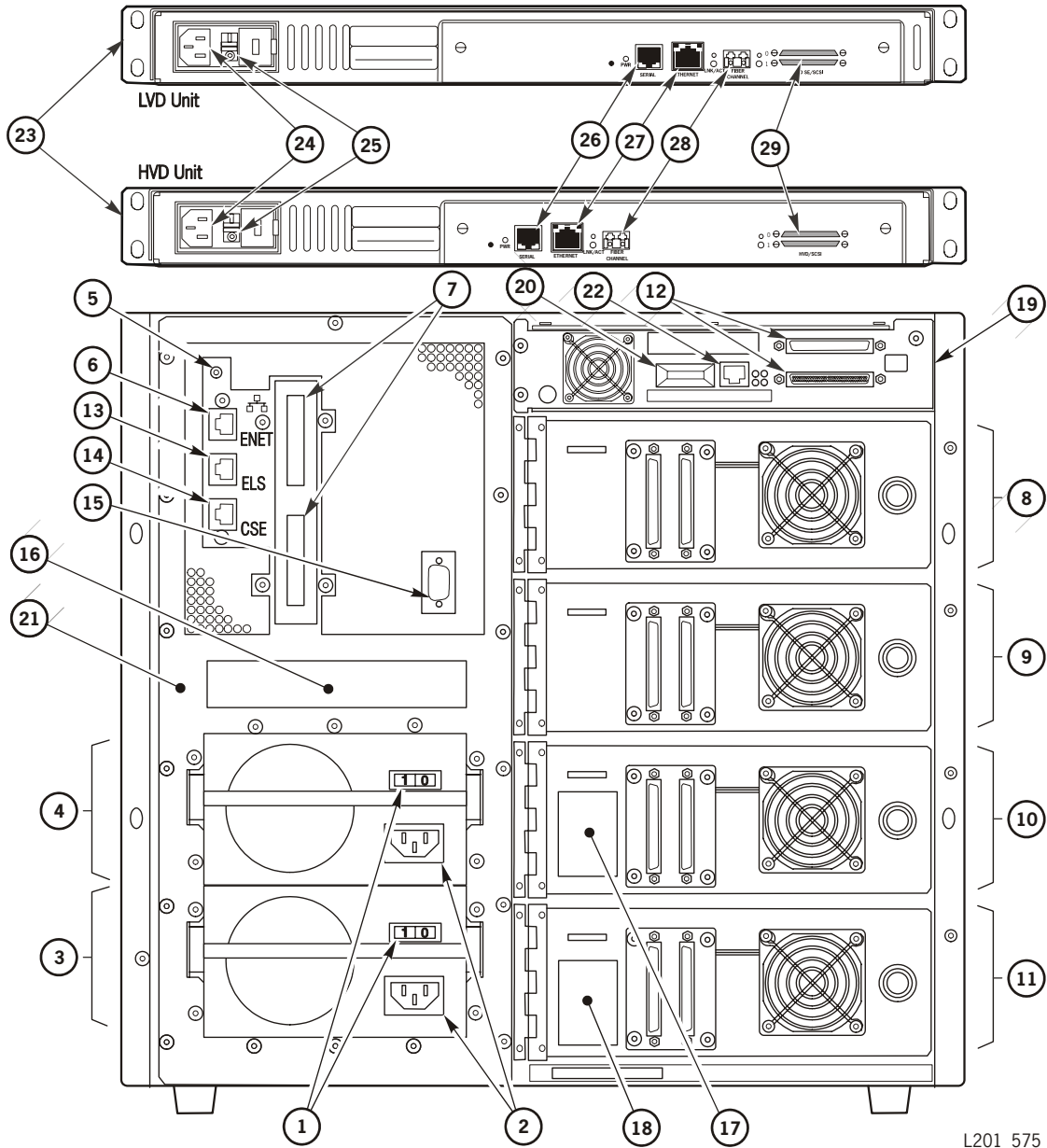

L201\_575

**Figure 2-2. Rear View of Components (Continued)** (I.201\_062)

---

1. Power-on/off switches	15. Personality module connector
2. Power receptacles	16. Library serial number and agency label
3. Standard power supply	17. Library warranty identification number
4. Redundant power supply	18. Dual power label
5. Library RESET button—use a wooden pencil (never a screwdriver or other electrically-conductive item) to press this button	19. Fibre Channel router card (optional)
6. Ethernet/Web port	20. Fibre Channel router card port
7. Library LVD/HVD SCSI ports	21. Electronics module
8. SCSI port for Drive 0 (See note.)	22. Fibre Channel router card CSE serial port
9. SCSI port for Drive 1 (See note.)	23. External Fibre Channel Router (optional)
10. SCSI port for Drive 2 (See note.)	24. External Fibre Channel Router Power Receptacle
11. SCSI port for Drive 3 (See note.)	25. External Fibre Channel Router Power Switch
12. Fibre Channel router card SCSI ports	26. External Fibre Channel Router Serial Port
13. Reserved for development engineers, not for customer use	27. External Fibre Channel Router Ethernet port
14. Customer Services Engineering (CSE) serial port	28. External Fibre Channel Router Fibre Channel port
	29. External Fibre Channel Router SCSI Bus ports

---

**Note:** The top drive that is installed is Drive 0. If all four drives are installed, the top drive is Drive 0 and the bottom is Drive 3. If drives are installed only in the two middle slots, the top drive installed is Drive 0 and the drive beneath it is Drive 1.

---

Figure 2-3. Internal View of Components (L201\_063)

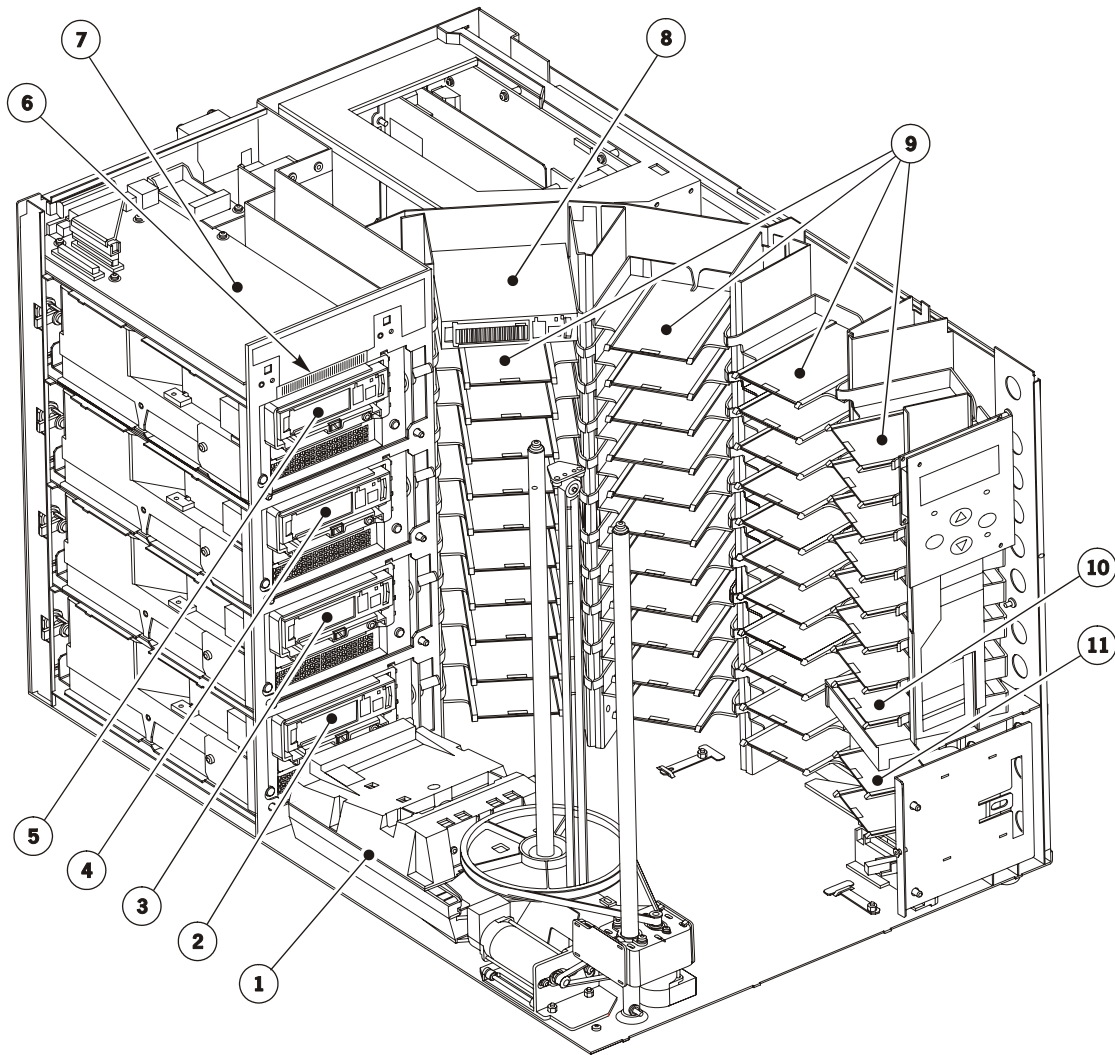

L201\_063

- |  |   |
|--|---|
| 1. Hand Assembly   | 7. Fibre Channel router card (optional)     |
| 2. Drive 3   | 8. Cartridge                                |
| 3. Drive 2   | 9. Columns 0 through 3, with 3 on far right |
| 4. Drive 1   | 10. Cleaning cartridge cell                 |
| 5. Drive 0   | 11. CAP cells (two)                         |
| 6. Library vision calibration label; the master target is below it |   |

Figure 2-4. Robotic Components (L201\_255)

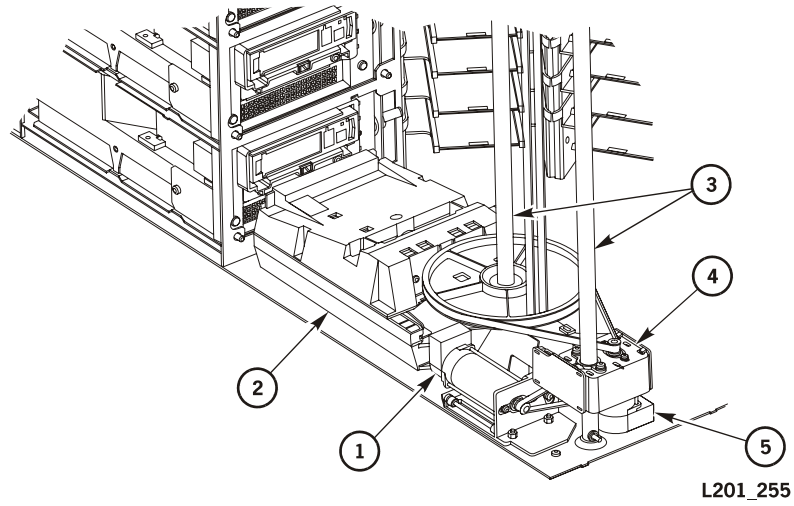

- |                  |                |
|------------------|----------------|
| 1. Z motor       | 4. Z carriage  |
| 2. Hand assembly | 5. Theta motor |
| 3. Z shafts      |                |

Figure 2-5. DLT Drive Label Locations (L201\_164)



1. FRU serial number
2. Warranty ID number
3. CEI serial number

Figure 2-6. Ultrium Drive Label Locations (L201\_165)



1. CEI serial number
2. FRU serial number
3. Warranty ID number

## ■ Specifications

The following pages provide library, drive, and cartridge specifications. See [Figure 2-7 on page 2-9](#) or [Figure 2-8 on page 2-10](#) for library installation dimensions.

For more specific drive and cartridge information, refer to the vendor Web site or documentation.

## Library Environment

The following table lists the library environment specifications.

**Table 2-1. Library Environment Specifications**

Item	Measurements		
	Operating	Storage	Transporting
Temperature	+10 to +40°C +50 to +104°F	+10 to +40°C +50 to +104°F	-40 to +60°C -40 to +140°F
Humidity	20 to 80%	10 to 95%	10 to 95%

**Table 2-1. Library Environment Specifications (Continued)**

Item	Measurements		
	Operating	Storage	Transporting
Wet bulb (maximum, noncondensing)	+29.2°C +84.5°F	+35°C +95°F	+35°C +95°F
Altitude	-76 to 3,048 m (-250 to 10,000 ft)		

## Library Power

The following table lists the power specifications for the library *without* drives.

**Table 2-2. Library Power Specifications**

Input voltage	100–240 VAC, single phase
Frequency	50/60 Hz
Maximum library power consumption	1.42 A at 120 V <i>or</i> 0.75 A at 240 V
Maximum heat output	614 Btu/hr
Voltage-amperes	180 VA

## Drive and Cartridge Weights

The following table lists the drive and cartridge weights. Refer to the drive publication and vendor Web site for updated information.

**Table 2-3. Drive and Cartridge Weights**

Item	Weight
DLT drive and tray	5.4 kg (12 lb)
DLT1 drive and tray	2.72 kg (6 lb)
Super DLT drive and tray	3.17 kg (7 lb)
DLT/DLT1/Super DLT cartridge	223 g (7.9 oz)
HP Ultrium LTO drive and tray	5.0 kg (11 lb)
IBM Ultrium LTO drive and tray	5.8 kg (12.7 lb)
Seagate Ultrium LTO drive and tray	5.5 kg (12 lb)
Ultrium 100 GB cartridge	220 g (7.8 oz)

## Drive Power

The following table lists the drive power specifications. Refer to the drive publication and vendor Web site for updated information.

**Table 2-4. Drive Power Specifications**

<b>Drive</b>	<b>Volt- Amperes</b>	<b>Current</b>	<b>Heat output</b>
DLT1	38 VA	0.30 A at 120 VAC 0.16 A at 240 VAC	130 Btu/hr
DLT 7000E	72 VA	0.59 A at 120 VAC 0.30 A at 240 VAC	256 Btu/hr
DLT 8000	65 VA	0.53 A at 120 VAC 0.27 A at 240 VAC	222 Btu/hr
Super DLT	58 VA	0.47 A at 120 VAC 0.24 A at 240 VAC	198 Btu/hr
HP Ultrium LTO	46 VA	0.37 A at 120 VAC 0.19 A at 240 VAC	157 Btu/hr
IBM Ultrium LTO	69 VA	0.56 A at 120 VAC 0.29 A at 240 VAC	236 Btu/hr
Seagate Ultrium LTO	47 VA	0.38 A at 120 VAC 0.20 A at 240 VAC	160 Btu/hr

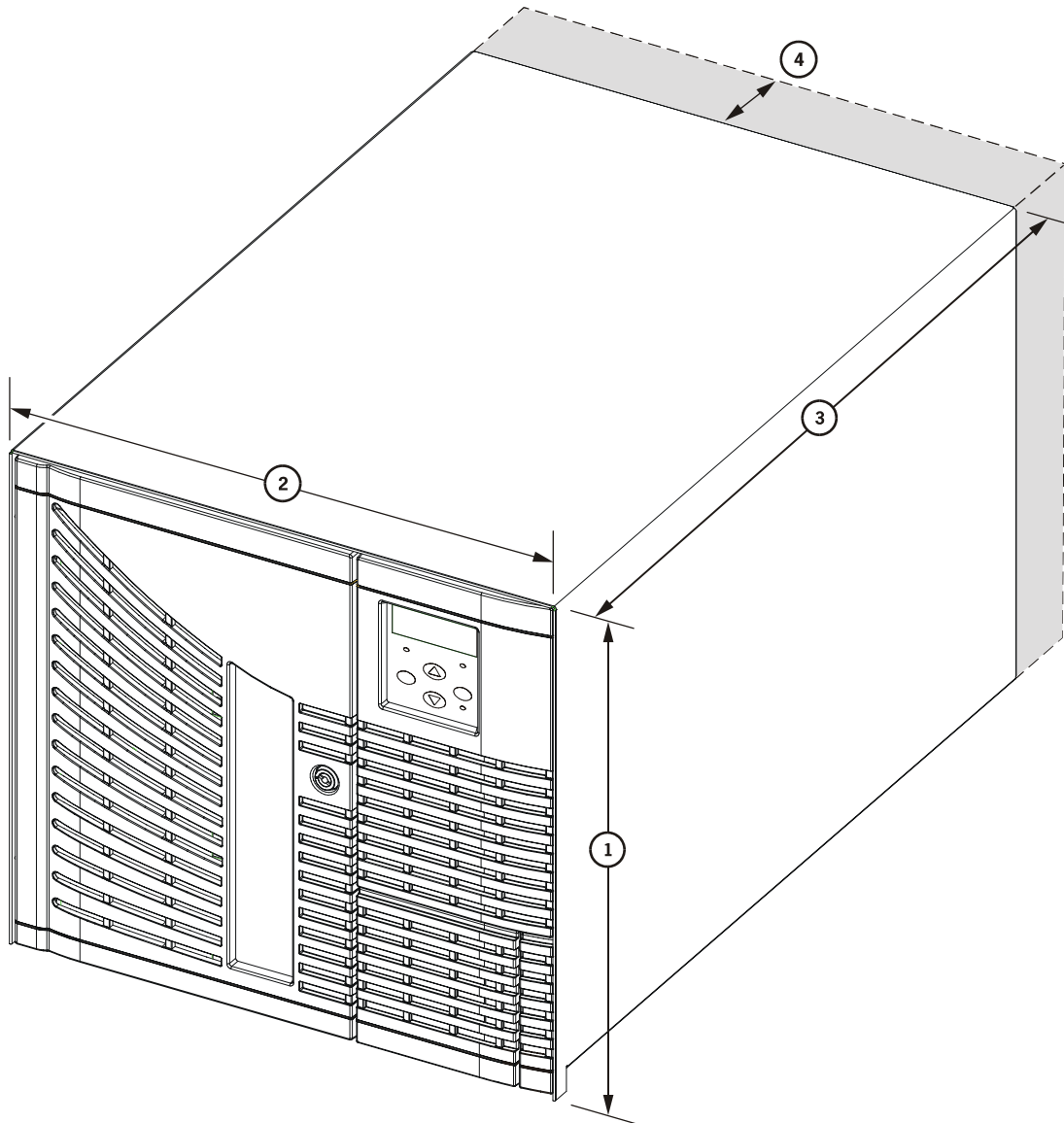

**Figure 2-7. L40 Desktop Version Dimensions and Weight (L201\_346)**

L201\_346

1. 455 mm (17.90 in.) height *with feet*; feet are 16 mm (0.625 in.).
2. 490 mm (19.30 in.) width
3. 724 mm (28.50 in.) depth *without external cables*
4. 102 mm (4.0 in.) dedicated fan exhaust clearance area (shaded area allows for cable and cooling clearances)

Weight (library only) 44.45 kg (98 lb)

Figure 2-8. L40 Rack Version Dimensions and Weight (L201\_343)

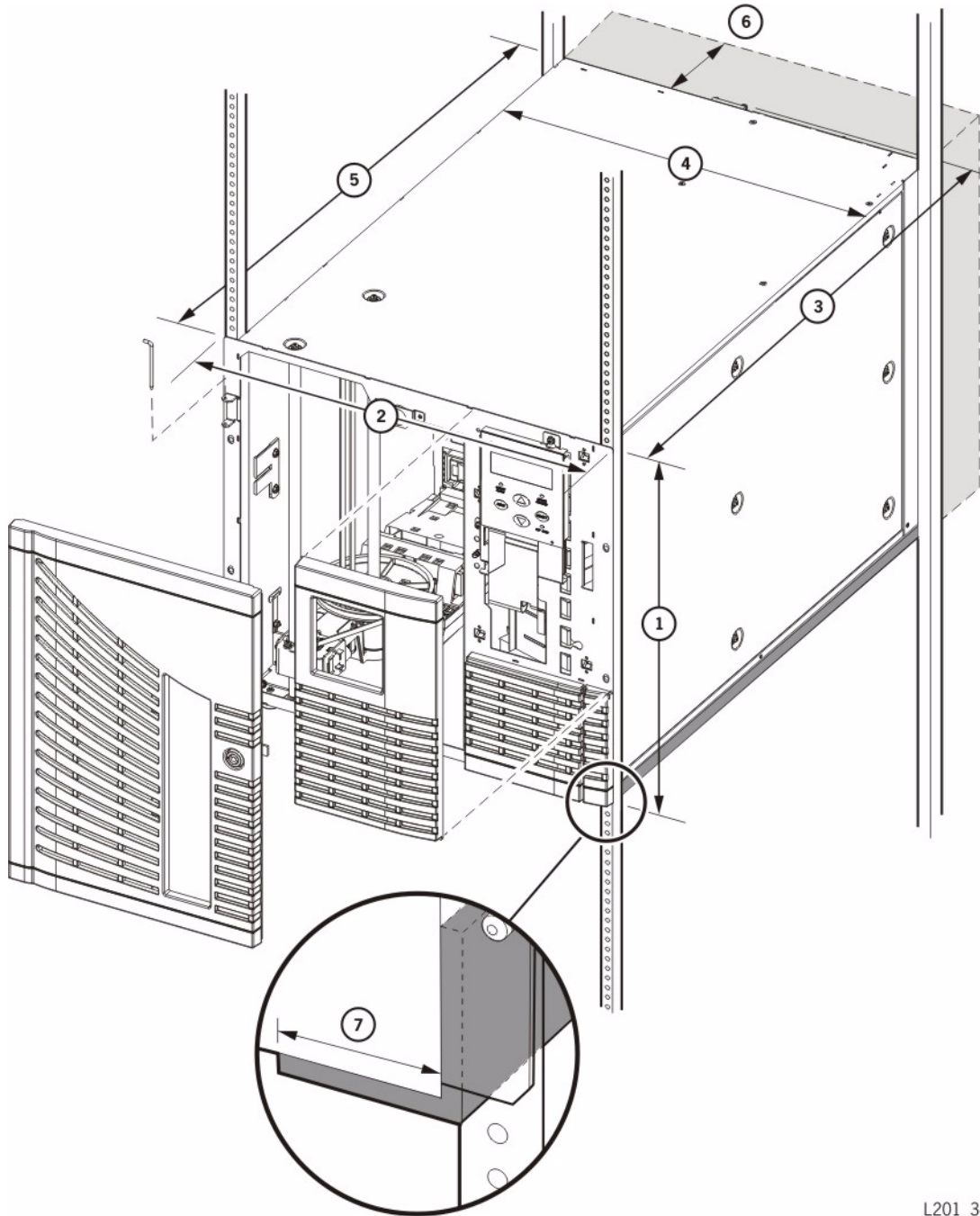

L201\_343

- |  |  |
|--|--|
| 1. 442 mm (17.39 in.) height                                   | 6. 102 mm (4.0 in.) dedicated fan exhaust clearance area (shaded area allows for cable and cooling clearances) |
| 2. 483 mm (19.0 in.) width of front with flange                | 7. 702 mm (27.65 in.) depth without fan, without cables  |
| 3. 728 mm (28.65 in.) depth <i>with fan, without cables</i>    |  |
| 4. 448 mm (17.65 in.) width                                    |  |
| 5. 702 mm (27.65 in.) depth <i>without fan, without cables</i> |  |

Weight (library only) 44.45 kg (98 lb)

## ■ Power Cord Numbers and Receptacles

Power cord part numbers for the library are listed in the table below. All cords are 3 m (9.8 ft).

The receptacle type is listed. Refer to your vendor catalog for the part number.

**Table 2-5. Country-specific Power Cords**

Input Voltage	Country	Part Number	Receptacle Type
100 to 127 VAC	U.S./Canada	10187019	5-15R
	Japan	10083243	JIS C8303
200 to 240 VAC	Australia	10083244	AS 3112
	Denmark	10083248	DEMKO107/ 10-1973
	Europe	10187018	Schuko
	Europe (Continental) See Note 2.	10187022	IEC309
	Italy	10083245	CEI 23-16/V11
	Korea	10083657	KSC 8305
	South Africa	10083636	BS546
	Switzerland	10083246	CEE 7
	United Kingdom	10083247	BS 1363
	U.S./Canada	10187020	6-15R

**Note:** This is a harmonic no plug cord for Belgium, Denmark, Finland, France, Germany, Holland, Norway, Sweden, and Switzerland.

**Table 2-6. Non-country-specific Power Cords**

Input Voltage	Description	Part Number
100 to 127 VAC	SJT IEC320 14AWG, 3 m, receptacle 5-15	10187061
250 VAC	SJT 16 AWG L6-15P, C13, 2.5 m, receptacle L6-15P	10187024
250 VAC	18, 3, SVT, 1mm, M/SH FRT	10187055
	3, F, IEC320 harmonized (see <b>Note</b> )	10187047
100 to 240 VAC	International power cord pigtail	10083735

**Note:** The cord has a plug on one end that attaches to the library and bare wires on the other. Buy the correct end to match your normal wall outlet and attach it to the cord.

## ■ External Cables

Use this table to select external cables. See [Table 2-5 on page 2-11](#) for the part numbers of power cords for specific countries.

**Note:** The SCSI universal cables listed below are intended for use with LVD application. The cables used to meet these requirements are inherently more costly and should be used only as required for HVD.

**Table 2-7. External Cables**

Description	Part Number
Cable assembly, 68 MD, 20 m (65.6 ft) (HVD use only)	10083312
Cordset, SJT, 16AWG, L6-15P	10083639
SCSI universal, 68MD-68MD, 500 mm (19.7 in.), LVD	10187005
SCSI universal, 68MD-68MD, 3 m (9.8 ft)	10187008
SCSI universal, 68MD-68MD, 5 m (16.4 ft)	10187009
SCSI universal, 68MD-68MD, 10 m (32.8 ft)	10187010
SCSI universal, 68MD-68HD, 3 m (9.8 ft)	10187011
SCSI universal, 68MD-68VHD, 5 m (16.4 ft)	10187012
SCSI universal, 68MD-68VHD, 10 m (32.8 ft)	10187013
Fibre Channel router RJ45 to DB9 adapter	10410823
Cable assembly, flat shield, SCSI 68, 300 mm (11.8 in.), HVD	313645101
Cable assembly, flat shield, SCSI 68, 600 mm (23.6 in.), HVD	313645201
Cable assembly, flat shield, SCSI 68, 1 m (39.37 in.), universal	313645302
Cable assembly, flat shield, SCSI 68, 300 mm (11.8 in.), LVD	313708802
Cable assembly, flat shield, SCSI 68, 600 mm (23.6 in.) LVD	313708902
Fibre Channel router serial cable with two RJ45 connectors; RJ45 Connector and Consultive Committee on International Telephony and Telegraph (CCITT) cable, 6.1 m (20 ft)	410828902

---

This appendix provides the implementation of the Simple Network Management Protocol (SNMP).

## ■ Overview

Sun StorageTek's L-series libraries support Version 1 of the simple network management protocol (SNMPv1). SNMP is an application layer protocol that performs network management operations over an Ethernet connection using a User Datagram Protocol (UDP/IP). Library microcode 2.11 or higher supports SNMP.

SNMP allows systems administrators to query the library for configuration, operation, and statistical information. SNMP also allows the library to inform the systems administrator of potential problems.

Systems administrators and network managers use SNMP to monitor and receive status from the library, such as:

- Operational state of the library (such as microcode level, serial number, online)
- Status of the cartridge access port (such as open, closed, number of cells)
- Library elements (number of hands, columns, panels, cells, CAPs)
- Number of storage cells and media types stored in the library
- Number and types of drives installed in the library
- Many other variables defined in the database

[Figure A-1 on page A-2](#) illustrates a simple network block diagram that identifies the locations of the SNMP software application, DNS servers, and Library Admin. This figure also identifies the IP addresses, shows a map of DNS names (library names), and other components involved in that configuration (such as operator panel, Ethernet connections, location of the Management Information Base (MIB), and the LLC card).

Figure A-1. SNMP and DNS Network Block Diagram Example (L201\_523)

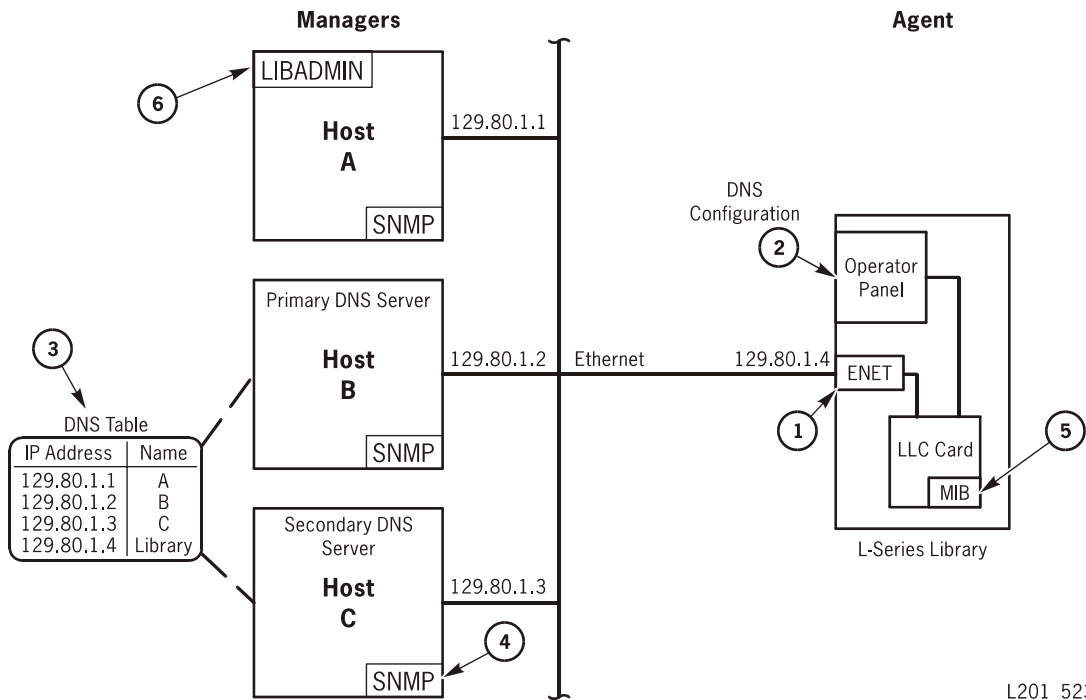

L201\_523

1. Ethernet connection (ENET) for the library.
2. To configure the library to support DNS.  
Note: You must enter the Domain Name Service (DNS) configuration *only* if your Simplified Network Management Protocol (SNMP) agent is set to trap *named* recipients; if SNMP is set for *numbered* recipients (by using IP addresses), no entries are required.
3. An example of a table that matches IP addresses to selected DNS names.
4. SNMP software application that implements the role of manager. Some applications include:  
HP Open View  
IBM NetView  
Sun Microsystems SunNet Manager
5. The MIB is stored on the LLC card. To view the contents of the MIB database, enter:  
`http://IP.Address/Lseries.mib` or `http://library_name/Lseries.mib`
6. Library Admin. is an *optional* feature for the library. It provides the GUI-based monitoring system and is *separate* from the SNMP application. Library Admin provides an easy and convenient way to configure the library SNMP agent using a network configuration panel or screen. Library Admin also provides other beneficial functions and display screens for the library.

## ■ SNMP Terms

SNMP uses a manager/agent structure, a database, and a small set of commands to exchange information. SNMP terms include:

- **Agent**—A module that resides in a managed device. The agent is responsible for responding to requests from the manager and for sending *traps* to a recipient that inform the systems administrator of potential problems.
- **Community String**—Applications use community strings for access control. The manager includes the community string in its SNMP messages to an agent. The agent consequently can accept or reject the operation.
- **Managed device**—A device that hosts the services of an SNMP agent that provides monitored information and controlled operations using SNMP. L-Series libraries are managed devices.
- **Management Information Base (MIB)**—A collection of information stored in a database that contains configuration and statistical information for a managed device. For L-Series libraries, a copy of the MIB is loaded with microcode and stored on the LLC card. See [“Management Information Base” on page A-4](#) for more information about the MIB.
- **Manager**—A thing that provides the communication link between the systems administrator and the managed devices on the network. A manager station or server allows the systems administrator to get information about the device through the MIB and to receive traps from an agent.
- **Recipient**—A location on a manager where the SNMP agent sends traps. This location is defined by the combination of either the IP address or DNS name and the port number. The default recipient port number is 162.
- **Trap**—A message that reports a problem, error, or a significant event that occurred within the device.

## ■ SNMP Commands

SNMPv1 offers a limited number of commands that follow a simple request/response exchange to communicate between the manager and the agent.

The **manager** issues request such as:

- Get—A request for information of a specific variable.
- GetNext—A request for the *next* specific variable.
- Set—A request to change the value of a specific variable.

The **agent** responds with:

- Get-Response—A response to the manager's Get and GetNext commands.
- Trap—An asynchronous message to the recipient about an error or event.

Refer to the SNMP software documentation for additional information.

## ■ Access Control

Because community strings provide a weak form of access control in SNMPv1, Sun StorageTek's embedded agent will not rely on the so called "private" community string in order to accept changes to the library's configuration. Access control and authorization for Set operations is performed by using an administrative password. Consequently, Sun StorageTek's embedded agent uses only one community string for both Get and Set operations.

## ■ Management Information Base

The MIB is a viewable document that contains descriptions about the characteristics for a managed device. These characteristics are the functional elements for that device which can be monitored using SNMP software.

To access and view the contents of the MIB using a Web browser, enter the IP Address or library name and Lseries.mib. For example: `http://IP.Address/Lseries.mib` or `http://library_name/Lseries.mib`.

**Note:** Sun StorageTek's L-series libraries implement only MIB extensions defined in the LSERIES-TAPE-LIBRARY-MIB under the **private (4)** section as shown in [Figure A-2 on page A-5](#).

[Figure A-2 on page A-5](#) shows the MIB hierarchy as a tree structure where the L-series MIB is located.



Figure A-2. Management Information Base Hierarchy (L201\_522)

MIB Title = LSERIES-TAPE-LIBRARY-MIB  
 Object Name = iso.identified-organization.dod.internet.private.enterprise.storagetek.products.lseries  
 Equivalent Object Descriptor = 1.3.6.1.4.1.1211.1.12

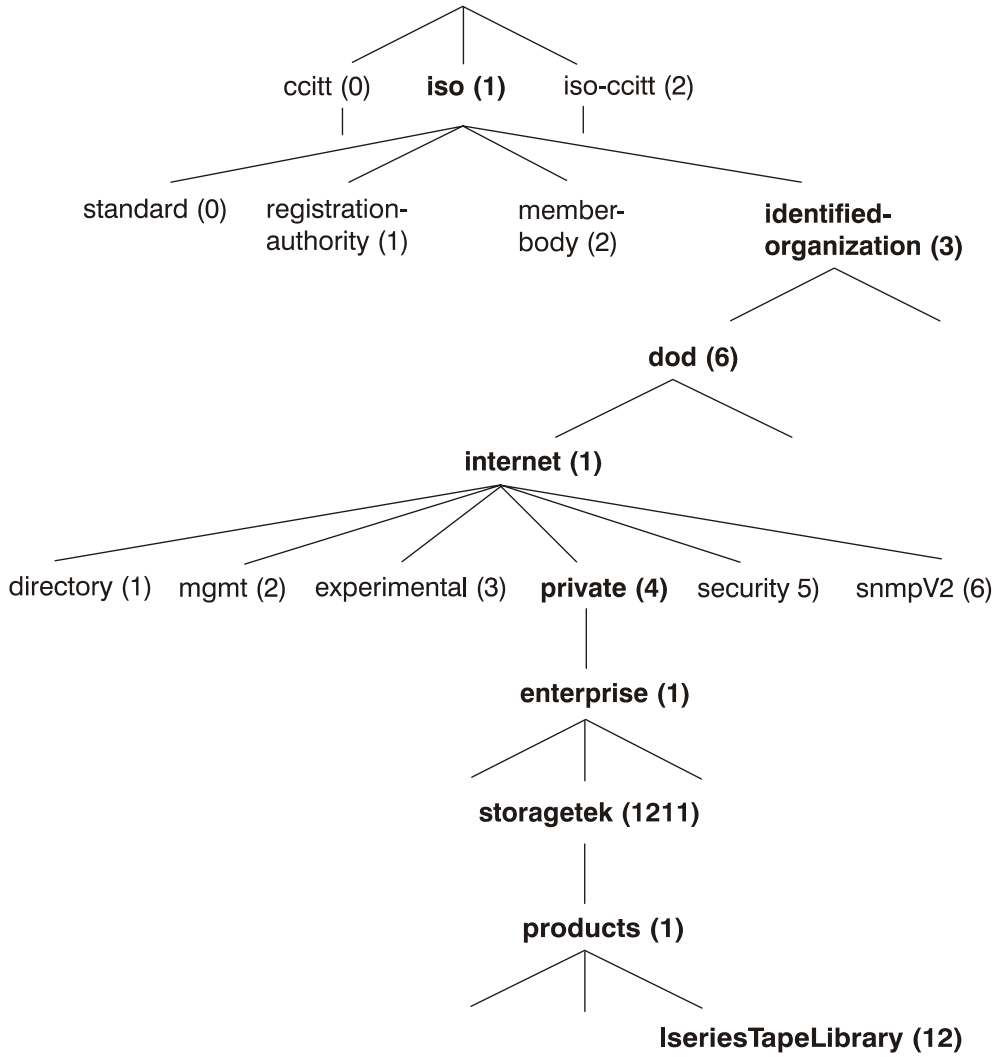

L201\_522

## ■ Configuration

Three ways to configure the library to support SNMP are:

- Library Admin, an *optional* feature for the library, but it is not required to support SNMP.
- The CLI port (command line interface)  
See [Figure A-3](#) for examples of the help and help snmp commands.
- The SNMP software application—you can also use any SNMP application to change *some* of the agent's settings. You must be MIB-aware and refer to the L-series.mib for specific information.

**Figure A-3. CLI Help and Help SNMP Commands**

```
cli> help
help [command]          help on a specific command
diag                   execute diagnostics
download               download new image to prom
fsc                   manipulate fault symptom codes
network               manipulate network information
snmp                 manipulate SNMP configuration
time                  view/modify library date & time
password              reset/modify library admin password

cli> help snmp
snmp view              display SNMP Agent settings
snmp community [string] set Community String/IP address
snmp [enable|disable] enable of disable SNMP Agent
snmp port [port number] set Agent Listening Port Number
                        (Valid: 161, 1024-65535)
snmp grace [number]   set Write Grace Period Number
                        ( 1-5 minutes )
snmp reset             set SNMP Agent configuration parameters
                        to default values
snmp list              display SNMP Trap Recipient List
snmp add               add a member to the SNMP Trap Recipient List by
                        answering individual prompts for values.
snmp add [ipaddr|name] add a member to the SNMP Trap Recipient List using
                        some default values
snmp add [ipaddr|name] [host port number] add a member to the SNMP Trap Recipient List
                        using some default values
snmp delete [[ipaddr|name] [host port number]] | all
                        delete all or a selected member of the SNMP
                        Trap Recipient List
                        Where valid [host port number] values: (162, 1024-65535)

cli> _
```

The library comes configured with some default settings, listed in [Table A-1](#):

**Table A-1. SNMP Default Settings**

Setting	Default	Description
Port number	161	Valid port IDs are 161, and 1024 to 65535
Community String	public	Agent community string. When set to <i>public</i> , requests coming from <i>any</i> community string will be accepted.
Grace Period	5 minutes	Once you enter the password, you have 1 to 5 minutes to <b>Set</b> any values for the agent.
Trap Recipient List	Empty	This list supports up to 12 recipients with no duplicate entries.
SNMP (agent)	Disabled	Enabled or Disabled

## ■ Starting SNMP

To start SNMP for the library, you must:

1. Configure the library:
  - a. *Enable* the agent
  - b. Add recipients to the trap list (if needed)
  - c. Make any optional changes to the default settings.
2. *Re-IPL* the library for the changes to take effect.

This page intentionally left blank.

# Index

---

## A

- AC power supply
  - location, 2-3
- access control, SNMP, A-4
- advertencia
  - mensajes en el manual, 1-xii
  - peso de la biblioteca en el bastidor, xxvii
  - vuelco del bastidor, 1-10
- advertencia, descripción, 1-xii
- alert messages in manual, 1-xii
- arm safety, xviii
- attaching
  - cell barrier clip, 1-19
  - personality module, 1-18

## B

- barrier, cell, 1-19
- bus, SCSI types, 1-12
- buttons
  - library reset, 2-3

## C

- cables
  - power, 2-11
- cables de fibra óptica
  - conectores, xxix
  - instalación, xxix
  - manipulación, xxix
- cables, external connections
  - Fibre Channel router example, 1-16
  - SCSI example, 1-15
  - SCSI restrictions, 1-12
  - terminator part numbers, 1-2, 1-14
- cartridge access port location, 2-2
- cartridges
  - inserting into library, 1-22
  - weight, 2-7
- caution
  - damaging hand, 1-3
  - drive weight, 1-26
  - gripping handles, fans, 1-9, 1-10

- installing daisy-chained drives, 1-26
- messages in manual, 1-xii
- mixing DLT cartridges, 1-23
- mixing interfaces on same bus, 1-13
- powering-off, 1-29
- safety precautions, xvii
- SCSI types on same bus, 1-12
- caution, description, 1-xii
- CEI serial number
  - DLT, 2-5
  - Ultrium, 2-6
- cell barrier clip, 1-19
- cells valid location, 1-21
- cleaning cartridge cell location, 2-4
- client-server cable, 1-15
- columns location, 1-21
- configuration
  - SNMP, A-6
- configuring library, recording information, 1-29
- connecting external cables
  - SCSI, 1-14
  - to Fibre Channel router, 1-16
- conventions in manual, xiii
- cord part numbers, 2-11
- CSE serial port location, 2-3
- Customer Resource Center (CRC), 1-xv

## D

- daisy-chained drives, 1-26
- DES
  - kit de puesta a tierra, contenido, xxx
  - precauciones y prevención, xxx
  - procedimientos a seguir durante tareas de mantenimiento o servicio técnico, xxx
- desktop installation
  - dimensions, 2-9
  - placement, 1-9
- dimensions
  - desktop installation, 2-9
  - rack installation, 2-10
- DLT. *See* drives
- Documents on CD, 1-xvi
- door lock location, 2-2

- drives
  - configuration table, 1-30
  - DLT labels, 2-5
  - installing, 1-26
  - interfaces, 1-25
  - location, 2-4
  - power specifications, 2-8
  - publications, xiv
  - recording configuration, 1-29
  - SCSI ports, 2-3
  - types, 1-14
  - Ultrium labels, 2-6
  - weights, 2-7
- dual power label location, 2-3

## E

- elbow safety, xviii
- electronics module location, 2-3
- environment specifications, 2-6
- ESD
  - grounding kit, contents, xxii
  - precautions and practices, xxii
  - procedures to follow when servicing, xxii
- Ethernet port location, 2-3
- etiqueta de producto láser, xxviii
- etiqueta, producto láser, xxviii
- external cables worksheet, 2-12

## F

- fiber-optic cables
  - connectors, xxi
  - handling, xxi
  - installation, xx
- Fibre Channel router
  - cable connections, 1-16
- fibres router card location, 2-3
- FRU serial number
  - DLT, 2-5
  - Ultrium, 2-6

## G

- Global Services Support Tools, 1-xvi
- grace period, SNMP, A-4
- grounding

- for safety, xvii
- kit, xxii
- procedures, xxiii

## H

- hand location, 2-4
- hand safety, xviii
- hardcopy publications, 1-xvi
- HVD
  - cable length restrictions, 1-13
  - SCSI connector label, 1-2

## I

- ID label
  - DLT warranty, 2-5
  - Ultrium warranty, 2-6
- inserting cartridges into cells, 1-20
- inspecting library and drives, 1-8
- instalación
  - cables de fibra óptica, xxix
- installation
  - cables to Fibre Channel router, 1-16
  - cell barrier clip, 1-19
  - connecting external cables, 1-14
  - desktop version, 1-9
  - fiber-optic cables, xx
  - inserting cartridges, 1-20
  - inspecting library, 1-8
  - personality module, 1-18
  - positioning library, 1-9
  - powering-on library, 1-29
  - preparing for, 1-5
  - preparing location, 1-8
  - quick, 1-1
  - rack version, 1-9
  - standard, 1-4
  - unpacking library, 1-5
- interfaces
  - drive, 1-25

## K

- kit, grounding, xxii
- kit, puesta a tierra, xxx

**L**

label, laser product, xx

laser product label, xx

library

cell barrier clip, 1-19

configuration table, 1-30

desktop installation, 1-9

dimensions and weight, 2-10

dual power label location, 2-3

electronics module location, 2-3

external cables worksheet, 2-12

inspecting, 1-8

installation, 1-1

personality module, 1-18

positioning, 1-9

power cord number worksheet, 2-11

powering-on, 1-29

rack version, 1-9

rear view, 1-18

reset button, 2-3

SCSI port, 2-3

serial number location, 2-3

specifications, 2-7

status port location, 2-3

unpacking, 1-5

warranty ID location, 2-3

lifting procedures, xviii

lifting safety, xviii

limits, SCSI cable length, 1-12

locations

AC power supply, 2-3

cartridge access port, 2-2

cells, 1-21

cleaning cartridge cell, 2-4

columns, 1-21

CSE serial port, 2-3

DLT labels, 2-5

door lock, 2-2

drives, 2-4

dual power label, 2-3

electronics module, 2-3

Ethernet port, 2-3

fibre router card, port, 2-3

hand, 2-4

library serial number, 2-3

Library Status port, 2-3

library warranty ID, 2-3

master target, 2-4

operator panel, 2-2

personality module, 2-3

power receptacle, 2-3

preparing installation, 1-8

reset button, 2-3

robotic components, 2-5

SCSI ports, 2-3

Ultrium labels, 2-6

vision calibration label, 2-4

LVD

cable length restrictions, 1-13

SCSI connector label, 1-2

**M**

Management Information Base. *See* MIB

master target location, 2-4

mensajes de alerta en el manual, 1-xii

MIB

described

hierarchy, illustrated, A-5

montaje en bastidor

seguridad, xxvii

**N**

notas, descripción, 1-xii

notes, description, 1-xii

**O**

operator panel location, 2-2

orienting cartridges correctly, 1-22

**P**

part numbers

power cables, 2-11

Partners Web site, 1-xv

peligro

para la vista a causa del láser, xxvii

personality module

attaching, 1-18

location, 2-3

placement of library, 1-9

ports location, 2-3

positioning library, 1-9

power

- cable part numbers, 2-11
- drive specifications, 2-8
- library specifications, 2-7
- receptacle location, 2-3

power cord number worksheet, 2-11

power supply locations, 2-3

powering-on library, 1-29

precaución

- mensajes en el manual, 1-xii
- peso de la unidad, 1-26

precaución, descripción, 1-xii

precauciones

- DES, xxx
- manipulación de cables de fibra óptica, xxix
- precauciones de seguridad, xxv
- seguridad, xxv

precautions

- ESD, xxii
- handling fiber-optic cables, xxi
- safety, xvii

preparing

- for installation, 1-5
- installation location, 1-8

prevención de DES, xxx

prevent ESD, xxii

procedimientos de levantamiento, xxvi

publications list, xiv

puesta a tierra

- kit, xxx
- procedimientos, xxxi
- seguridad, xxv

## Q

quick installation procedure, 1-1

## R

rack installation

- dimensions, 2-10
- guidelines, 1-9

rack-mounting

- safety, xix

recording configuration information, 1-29

reset button

- location, 2-3

restrictions, SCSI, 1-12

robot components, 2-5

## S

safety

- arm, xviii
- fiber optics, xix
- general, xvii
- grounding, xvii
- laser product label, xx
- lifting, xviii
- precautions, general, xvii
- rack-mounting, xix

SCSI

- cable length restrictions, 1-12
- cabling figure, 1-15
- ports location, 2-3
- terminator, 1-14

seguridad

- brazos, xxvi
- etiqueta de producto láser, xxviii
- fibras ópticas, xxvii
- general, xxv
- levantamiento, xxvi
- montaje en bastidor, xxvii
- precauciones, generales, xxv
- puesta a tierra, xxv

seguridad de brazos, xxvi

seguridad de codos, xxvi

seguridad de hombros, xxvi

seguridad de levantamiento, xxvi

seguridad de manos, xxvi

seguridad de muñecas, xxvi

serial number location, 2-3

- DLT, 2-5
- Ultrium, 2-6

shoulder safety, xviii

SNMP

- access control, A-4
- commands, A-4
- configuration (through CLI port), A-6
- configuration (with Library Admin), A-6
- configuration (with software application), A-6
- grace period, A-4
- illustrated, A-2

specifications

- drive and cartridge weights, 2-7



- drive power, 2-8
- library, 2-6
- SCSI, 1-12
- standard installation procedure, 1-4
- storage cells location, 1-21

## T

- table, configuration, 1-30
- tape drives *See* drives.
- terminator, SCSI, 1-14

## U

- Ultrium. *See* drives
- unpacking library, 1-5

## V

- vision calibration label location, 2-4

## W

- wall receptacle worksheet, 2-11
- warning
  - eye hazard from laser, xix
  - library weight in rack, xix
  - messages in manual, 1-xii
  - tipping rack, 1-10
- warning, description, 1-xii
- warranty ID location, 2-3
- warranty ID number
  - DLT, 2-5
  - Ultrium, 2-6
- weights
  - drives and cartridges, 2-7
  - library, 2-9
- worksheets
  - external cables, 2-12
  - power cord number, 2-11
  - wall receptacle, 2-11
- wrist safety, xviii





Sun Microsystems, Inc. 4150 Network Circle, Santa Clara, CA 95054 USA Phone 1-650-960-1300 or 1-800-555-9SUN Web [sun.com](http://sun.com)



ARGENTINA: 5411-4317-5636 • AUSTRALIA: 1-800-550-786 • AUSTRIA: 43-1-601-26-0 • BALKANS: 301-6188-111 • BELGIUM: 32-2-704 89 83 • BRAZIL: 55-11-51872100 • BRUNEI: 65-216-8333 • CANADA: 1-800-422-8020 (GENERAL); 416-964-2001 (LEARNING MANAGEMENT SYSTEM SALES, TORONTO) • CHILE: 562-372-4500 • COLOMBIA: 571-629-2323  
CZECH REPUBLIC: 420-2-33009311 • DENMARK: 45-4556-5040 • EGYPT: 00-202-570-9442 • FINLAND: 358-9-525-551 • FRANCE: 33-1-41-33-17-17 • GERMANY: 49-89-460-08-2788 • GREECE: 30-01-6188101 • HONG KONG: 852-2877-7077 • HUNGARY: 361-202-4415 • INDIA: 91-80-229-8989 • INDONESIA: 65-216-8333 • IRELAND: 353-1-668-4377  
ISRAEL: 972-9-9710500 • ITALY: 39-02-9259511 • JAPAN: 81-3-5779-1820 • KOREA: 82-2-3453-6602 • MALAYSIA: 603-2116-1887 • MIDDLE EAST: 00-9714-3366333 • MEXICO: 525-261-0344 • NETHERLANDS: 31-33-4515200 • NEW ZEALAND: 0800-786-338 • NORTH WEST AFRICA: 00-9714-3366333 • NORWAY: FROM NORWAY: 47-22023950, TO NORWAY: 47-23369650 • PAKISTAN: 00-9714-3366333 • PEOPLE'S REPUBLIC OF CHINA: 8610-6803-5588 • PHILIPPINES: 632-885-7867 • POLAND: 48-22-8747848 • PORTUGAL: 351-21-413-4000 • RUSSIA: 7-095-935-8411 • SAUDI ARABIA: 00-9714-3366333 • SINGAPORE: 65-216-8300 • SOUTH AFRICA: 27-11-256-6300 • SPAIN: 34-902-210-412 • SRI LANKA: 65-2168333 • SWEDEN: 46-8-631-22-00 • SWITZERLAND: 41-1-908-90-50 (GERMAN) 41-22-999-0444 (FRENCH) • TAIWAN: 886-2-25185735 • THAILAND: 662-344-6855 • TURKEY: 90-212-335-22-00 • UNITED KINGDOM: 44-1276-416-520 • UNITED STATES: 1-800-422-8020 • VENEZUELA: 582-905-3800 • VIETNAM: 65-216-8333 • WORLDWIDE HEADQUARTERS: 1-650-960-1300

**SUN™** THE NETWORK IS THE COMPUTER ©2006 Sun Microsystems, Inc. All rights reserved. Sun, Sun Microsystems, and the Sun logo are trademarks or registered trademarks of Sun Microsystems, Inc. in the United States and other countries.