

OPERATOR'S MANUAL

48" ROTARY TILLER

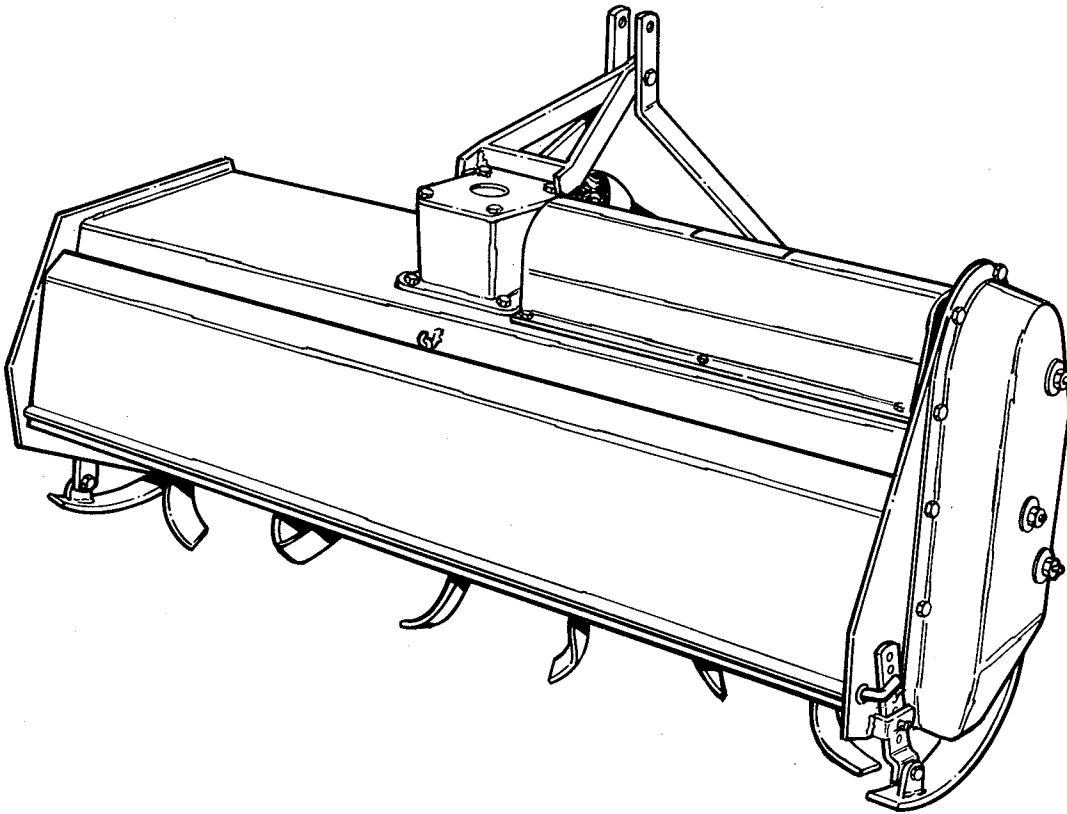

48" ROTARY TILLER
MFG. NO. 1600199



**CAUTION: Read Manual Thoroughly
Before Operating**

FORM - 1652005
PRINTED IN U.S.A.
7612

Dear Customer,

Congratulations on your purchase of this rotary tiller. It has been carefully designed and built to give you years of dependable service. With proper care, it will help you do your tilling jobs for years to come.

To make sure you get the best use from your rotary tiller, study this manual carefully. Make sure that it is installed properly. Be sure that you (and anyone who operates this machine) know how to use the machine safely. Read this manual and the tractor manual thoroughly and become familiar with the controls of the machine before operating.

For your own safety as well as others, study the safety rules in this manual and those in the tractor manual. Review this information often. It is there for your benefit and is important.

This manual tells how to install, service, and operate your rotary tiller. If any help is needed with any of these procedures, your dealer will be happy to help you.

Measurements are given in this manual with metric equivalents in parentheses. For example, behind the measurement 1/8 inch would appear: (3 mm). So, the metric equivalent of 1/8 inch is 3 millimetres.

These metric measurements are provided for your convenience as an aid in converting to the metric system. A list of metric terms and abbreviations used in this manual is provided below.

LIST OF ABBREVIATIONS OF METRIC TERMS

1. mm = millimetre
2. kg = kilogram
3. N-m = newton-metre

48 Inch Rotary Tiller

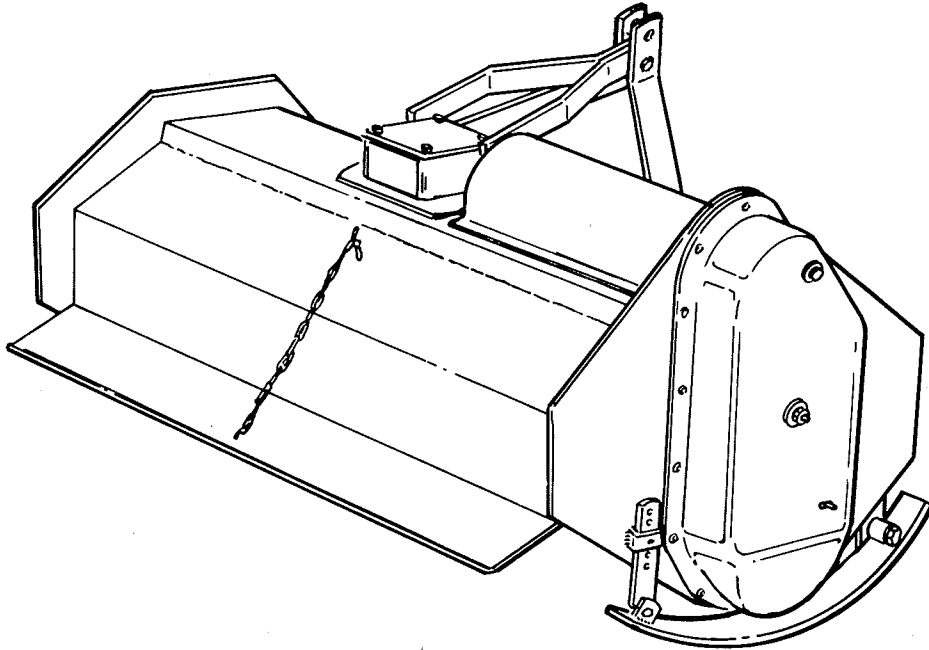

Table of Contents

SAFETY RULES	2
IDENTIFICATION	4
ACCESSORIES AND ATTACHMENTS	4
INSTALLATION	5
REQUIRED ACCESSORIES.....	5
INSTALLATION	5
REMOVAL.....	6
OPERATION	7
NORMAL CARE.....	9
SCHEDULED CARE.....	9
NORMAL STORAGE.....	9
OFF-SEASON STORAGE.....	9
TROUBLESHOOTING	11
TROUBLESHOOTING PROCEDURES	11
TINE REPLACEMENT.....	12
CHAIN REPLACEMENT	12
ADJUSTMENTS.....	13
MAINTENANCE RECORD	14
SPECIFICATIONS	15



WARNING

Read these safety rules and follow them closely. Failure to obey these rules could result in loss of control of vehicle, severe personal injury to yourself or bystanders, or damage to property or equipment affecting safety.

Safety Rules



This notation preceding Cautions and Warnings in the text signifies important precautionary steps which, if not properly followed, could result in personal injury or damage to your equipment affecting safety.

General

- Read the operator's manual carefully. Be thoroughly familiar with the controls and proper use of the equipment. Know how to stop the unit and disengage the controls quickly.
- Never allow children to operate equipment. Never allow adults to operate equipment without proper instructions.
- Keep the area of operation clear of all persons, especially small children, and pets.
- Use only attachments and accessories designed for your machine. See your dealer for a complete list of approved attachments and accessories.

Preparation

- Never attempt to make any adjustments while engine is running.
- Thoroughly inspect the area where the rotary tiller is to be used and remove wires and other foreign objects which might get tangled on tines.
- Disengage all clutches and shift into neutral before starting engine.
- Handle gasoline with care, it is highly flammable.
 - a. Use approved fuel container.
 - b. Never add fuel to a running engine or hot engine.
 - c. Fill fuel tank outdoors with extreme care. Never fill fuel tank indoors.
 - d. Replace gasoline cap securely and wipe up spilled fuel.

Operation

- Stay alert for hidden hazards or traffic. Do not carry passengers.
- After striking a foreign object, stop the engine, disengage power take-off(s), and remove ignition key. Thoroughly inspect the rotary tiller for any damage before restarting and operating the rotary tiller.
- Never operate rotary tiller without guards, plates, or other safety protective devices in place.
- Do not till across the face of slopes. Exercise extreme caution when changing direction on slopes. Do not attempt to till steep slopes. Use front weights whenever operating rear-mounted attachments on slopes. Use rear wheel weights when needed for traction or counterweighting and to operate on slopes greater than 20 percent (11.3°). Never operate on slopes greater than 35 percent (19.3°).

- Stop engine, disengage power take-off(s), and remove ignition key whenever you leave the operating position and before making repairs, adjustments, or inspections.
- Take all possible precautions when leaving the vehicle unattended. Disengage power take-off(s), lower the attachment, shift into neutral, set the parking brake, stop the engine, and remove the key.
- When cleaning, repairing, or inspecting, make certain rotary tiller and all moving parts have stopped. Remove ignition key to prevent accidental starting.
- Never allow anyone in back of unit.
- Disengage power to rotary tiller when transporting or not in use.
- Use only attachments and accessories approved by manufacturer of rotary tiller (such as wheel weights, chains, etc.).
- Never operate the rotary tiller without good visibility or light. Always be sure your feet are properly placed on the footrests and keep a firm hold on the steering wheel.
- Be especially careful not to touch tractor or attachment parts which might be hot from operation. Allow such parts to cool before attempting to maintain, adjust, or service.

Maintenance and Storage

- Check bolts, nuts, spring clips, etc. at frequent intervals for proper tightness to be sure equipment is in safe working condition.
- Always refer to operator's manual for important details if rotary tiller is to be stored for an extended period.

Identification

When ordering replacement parts for your rotary tiller, be prepared to give your dealer the identification number found on the identification plate shown below. We suggest that you locate the number and record it below for easy reference.

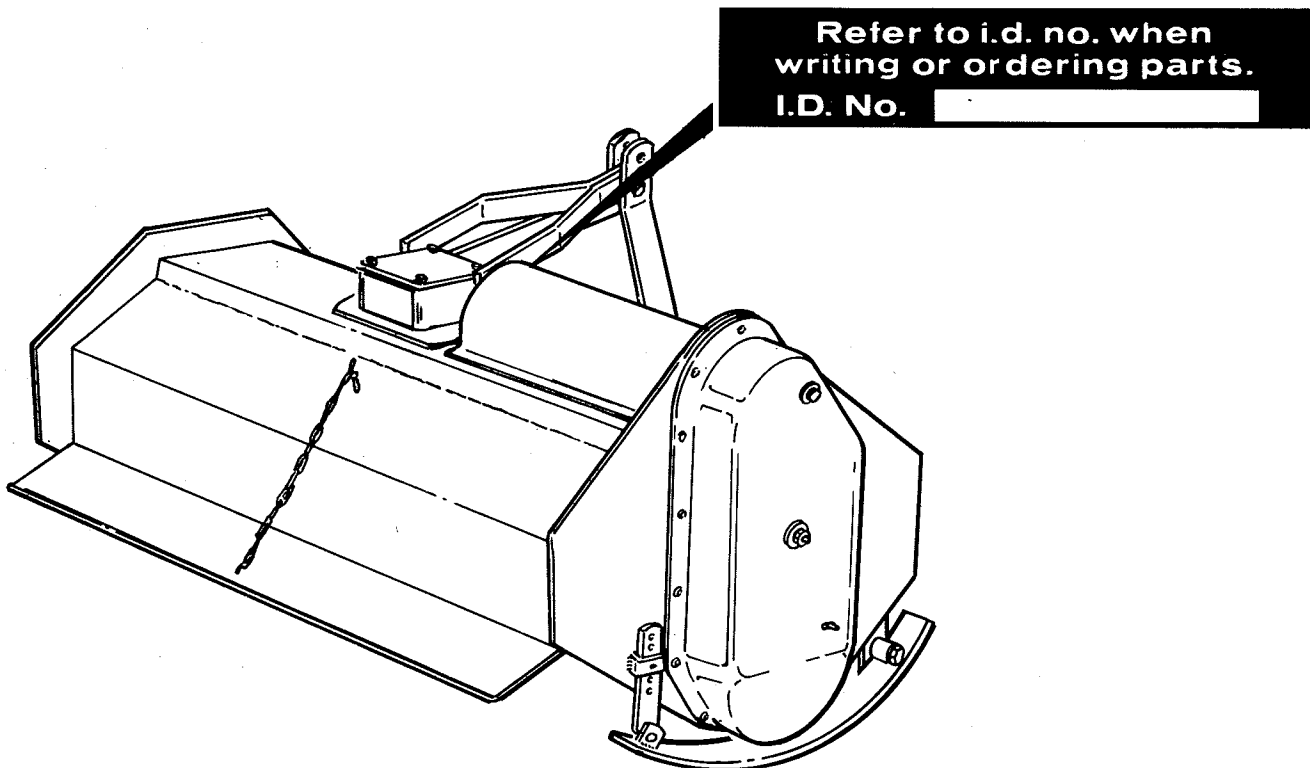

Accessories and Attachments

There are optional accessories and attachments available for your tractor and rotary tiller. See your dealer if you wish to purchase any of the following:

3-POINT HITCH — required to raise and lower rotary tiller.

REAR POWER TAKE-OFF — required to drive rotary tiller.

FRONT BUMPER — needed to mount front counterweight.

FRONT COUNTERWEIGHT — improves steering ability when rotary tiller is installed.

WHEEL WEIGHTS, REAR — improve traction in wet or loose soil.

HOURLY METER — helps insure that scheduled care is done on time.

TIRE CHAINS — improve traction in damp soil.

REAR LIGHT KIT — illuminates work area for rear-mounted attachments.

Installation

CONTENT OF SECTION

Before it can be used, the rotary tiller must be installed on your tractor. This section tells you how the rotary tiller should be installed. It also tells you how to remove the rotary tiller from the tractor.

REQUIRED ACCESSORY

A 3-point hitch and a rear power take-off are required to install and operate the rotary tiller. If your tractor is not equipped with these items, kits must be bought and installed. See your dealer.

INSTALLATION

Install the rotary tiller on your tractor as follows:

1. Set up 3-point hitch (figure 1) on tractor as follows:
 - Be sure draft arms (item D) are attached to upper holes of lower lift links (item C).
 - Be sure upper lift link (item A) is mounted in upper hole of bracket (item B).
 - Be sure eyebolts (item E) are mounted on top of drawbar.
 - Be sure large diameter end of each float lockout pin (item H) is protruding out of trunnion (item G). If not, move spring clips and push smaller diameter end into trunnion.

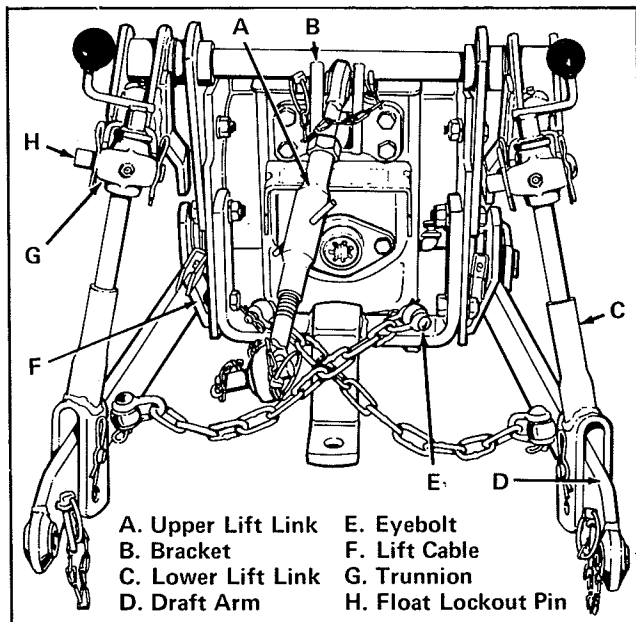

Figure 1. Set Up 3-Point Hitch

- Be sure center lift cables (item F) are detached from rear hitch. If you must detach cables, use pins and spring clips to fasten front ends of these cables to the tractor footrests.
2. Back tractor into position in front of rotary tiller. Stop so swivel sockets (item B, figure 2) are aligned with tiller hitch pins (item C).
 3. Operate rear lift lever to position swivel sockets (item B) at same height as tiller hitch pins (item C).
 4. Stop engine, remove ignition key, and set parking brake.
 5. Slide swivel sockets onto tiller hitch pins. Use leveling cranks (item A) to move sockets up or down as needed.
 6. Install safety pins (item D) through holes in ends of tiller hitch pins.

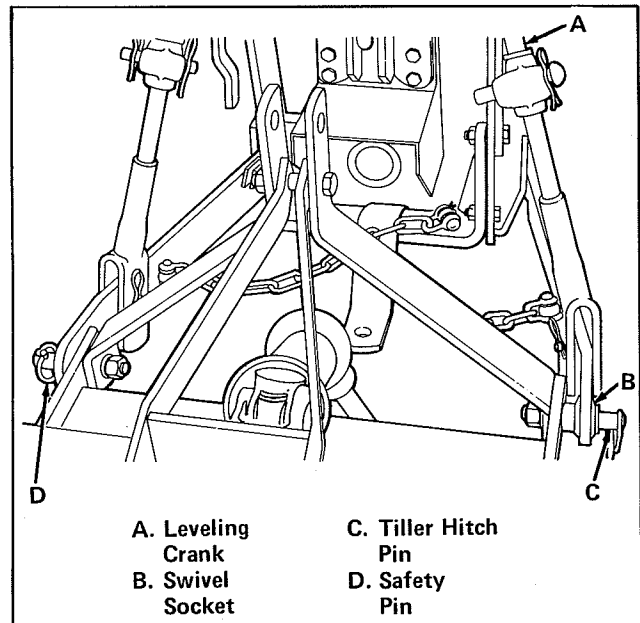

Figure 2. Attach Swivel Sockets

7. Be sure splines on tiller drive shaft (item C, figure 3) are clean. Then push locking collar (item A) forward while inserting drive shaft splines into tractor PTO (item B). Release locking collar when drive shaft splines are fully inserted. Be sure lock is engaged by trying to pull drive shaft out of PTO.

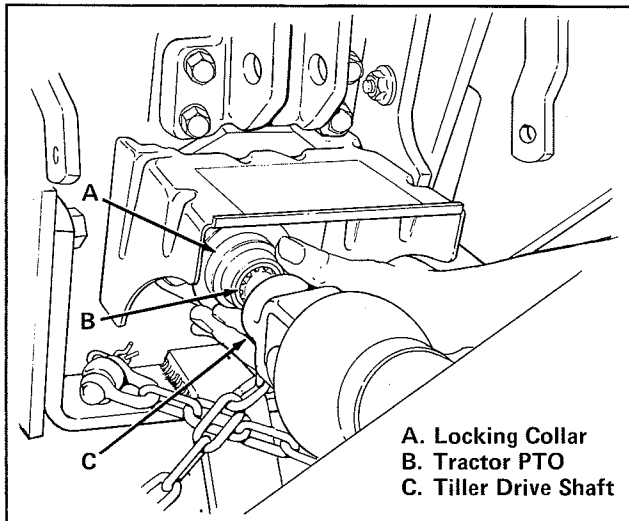

Figure 3. Connect Tiller Drive Shaft

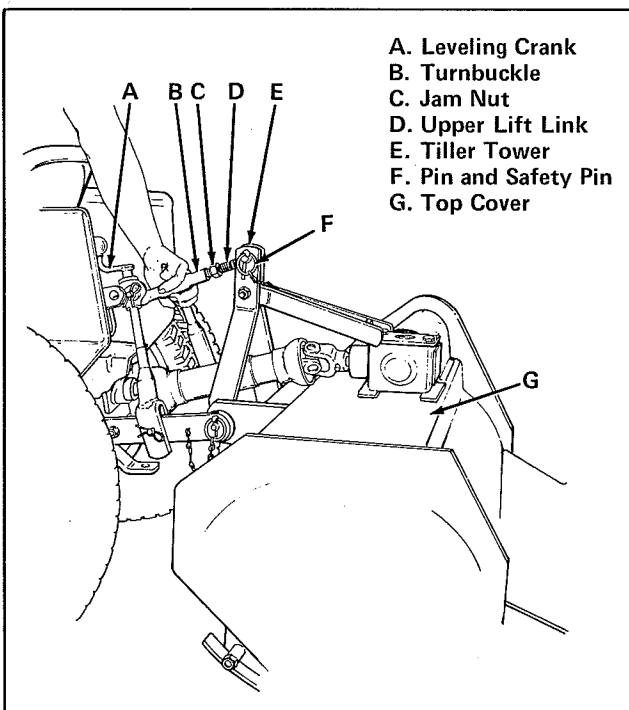

Figure 4. Attach Upper Link

8. Attach upper lift link (item D, figure 4) to tiller tower (item E). Secure the upper lift link with the combination pin and safety pin (item F).
9. Turn leveling cranks (item A) fully clockwise for best ground clearance during transport.
10. With tiller resting on ground, top cover (item G) of tiller should be leveled front to back. If not, loosen jam nut (item C) and adjust turnbuckle (item B).
11. Be sure jam nut (item C) is tightened firmly against turnbuckle (item B).

REMOVAL

To remove the rotary tiller from the tractor, proceed as follows:

WARNING

Stop engine, remove ignition key, set tractor parking brake, and be sure tiller tines have stopped rotating before working on or near rotary tiller.

1. Place tractor rear lift control in its float position to lower tiller to ground.
2. Remove combination pin and safety pin (item F, figure 4) and detach upper lift link (item D) from tiller tower (item E). To prevent loss, reinstall pin and safety pin in hole of upper lift link.
3. Push locking collar (item A, figure 3) forward while pulling tiller drive shaft (item C) out of tractor PTO (item B).
4. Remove safety pins (item D, figure 2) and slide swivel sockets (item B) off tiller hitch pins (item C).
5. Push draft arms of 3-point hitch down so swivel sockets are clear of tiller hitch pins. Then drive tractor forward.

Operation

CONTENT OF SECTION

A brief description of the rotary tiller controls, followed by the basic operating procedures, is given in this section to help you get to know your rotary tiller and how to operate it safely and efficiently.

ROTARY TILLER CONTROLS

The rotary tiller is operated using controls on the tractor. Figure 5 shows the locations, names, and functions of these controls. The control names given in figure 5 are used throughout the manual.

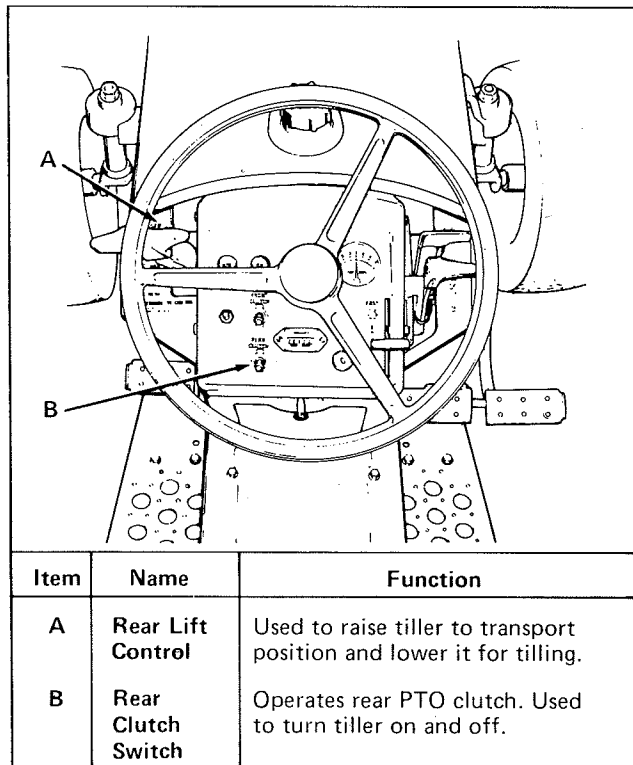

Figure 5. Locations and Functions of Controls

OPERATING PROCEDURES

The rest of this section tells you how to operate your rotary tiller. The directions assume that both the rotary tiller and tractor work properly. If not, refer to the troubleshooting sections of this manual and the tractor manual.

CHECKS BEFORE STARTING

The checks listed below should be performed before each use of the rotary tiller.

WARNING

Before attempting to inspect, adjust, or service the rotary tiller make sure the REAR CLUTCH switch is off, the engine stopped, the key removed, and tiller is lowered to the ground.

1. Read this manual. Read the tractor operator's manual. Be sure you know safety precautions and locations and uses of operating controls.
2. Check the rotary tiller to insure that it is properly installed on tractor. Be sure that all safety guards are in place and that all nuts, bolts, and spring clips are secure.
3. Refer to Normal Care section of this manual to determine and perform any needed care for the rotary tiller. Do the same for the tractor.
4. Clear the area you intend to till to be sure that it is free of all items that may be caught in or thrown by the rotary tiller.

TRACTOR AND TILLER OPERATION

The tractor supplies both the power and forward motion for the rotary tiller. Therefore, tractor operation is vital to proper rotary tiller operation. Details for rotary tiller operation are given in paragraphs that follow. Read all of these paragraphs. Then read the general operating procedure for tractor operation with attachments given in the tractor manual before attempting to use the rotary tiller.

Raising and Lowering the Rotary Tiller

Use the rear lift control (item A, figure 5) to raise and lower the rotary tiller. Pull this control rearward to raise the tiller; release it and allow it to return to its hold position to keep the tiller raised. To lower the tiller, push the rear lift control forward to its float position.

CAUTION

The rear lift control must be in its float position when you are tilling. The float lockout pins must also be in the float position. Otherwise, the tiller can propel the tractor.

Steering with Rotary Tiller Installed

The weight of the rotary tiller behind the tractor reduces weight on the front wheels. Use of the front counterweight is recommended to restore the normal turning ability of the tractor. Even with the weight installed, avoid "jack-rabbit" starts and adjust the tractor speed to fit the condition of the surface on which you are traveling.

Turning or Backing with Rotary Tiller

Before backing up the tractor or turning the tractor sharply, always raise the tiller until it is clear of the ground. Otherwise, the tiller can be damaged.

Transporting the Rotary Tiller

When you use the tractor to transport the rotary tiller to and from work areas, the rotary tiller should be fully raised. Also be sure the REAR CLUTCH switch is set to its off position to disengage the tiller.

Engine Speed for Tilling

Operate the engine at 3/4 to full speed for normal tilling. Full engine speed will be necessary when tilling depth and ground conditions require full engine power.

Tractor Speed for Tilling

The tractor speed affects the tilling depth and the size of the soil particles. The best speed is determined by the soil conditions and land contours. For most conditions, the best speed is obtained in first gear. You may be able to use second gear in soft, loose soil. In either gear, adjust the hydrostatic control for the desired results.

Stopping the Rotary Tiller

To stop the rotary tiller while it is in operation, flip the REAR CLUTCH switch (item B, figure 5) down and stop the tractor. Do this immediately if you strike rocks that jam and stop the tines.

NOTE

After striking a foreign object, stop the engine, disengage PTO, remove ignition key, and lower tiller to the ground. Thoroughly inspect the rotary tiller for any damage before restarting.

Shield Position

The shield (item A, figure 6) prevents throwing of loosened soil and rocks. The rear of this shield should rest on the ground when the tiller is at the desired depth. To adjust the shield height, place

different chain links over the hook (item B). For finer adjustment, you can also twist the chain.

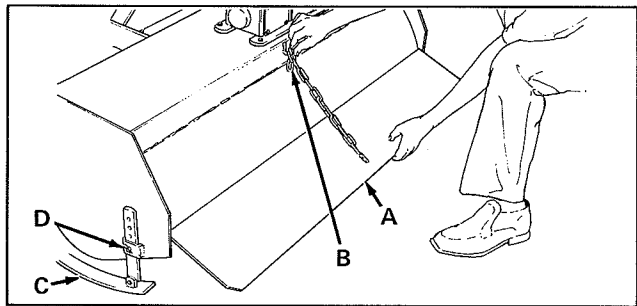

Figure 6. Shield and Skid Shoes

Starting the Rotary Tiller

To start the rotary tiller into operation, stop the tractor and proceed as follows:

1. While tiller is raised so tines clear ground, set REAR CLUTCH switch to its on position.
2. Push rear lift control fully forward to its float position to lower rotary tiller.
3. When tines have dug down and skid shoes are resting on ground, start tractor forward. Adjust tractor speed as you proceed to keep skid shoes on the ground.

Tilling Depth

You will want to till to a depth that suits the seed you will plant. As a rule, till at least 2 inches (50 mm) deeper than the normal planting depth for the seed. The usual planting depth for corn, as an example, is 2 to 3 inches (50 to 76 mm). Using the rule above for this example, till the soil to a depth of 5 inches (127 mm) or more.

If you till too deeply in a single pass, the soil texture will be coarse. The problem can be avoided by making a number of passes over the same area. Till to a shallow depth on the first pass. Then increase the depth on each additional pass until the seedbed has the proper depth and texture.

To control the tilling depth, raise or lower the rotary tiller by adjusting the skid shoes (item C, figure 6). Make this adjustment as follows:

1. Stop tractor, set parking brake, and be sure REAR CLUTCH switch is off.
2. Raise rotary tiller to its transport position.
3. Stop engine and remove ignition key.
4. Remove spring clip and pin (item D) and slide skid shoe up or down to desired height. Then reinstall pin and spring clip to secure skid shoe. Be sure both skid shoes are set to same height.

Normal Care

CONTENT OF SECTION

Your rotary tiller was designed and built to provide years of service with only minor care. This care, however, must be performed to keep it in good operating condition and to avoid costly repairs. This section shows you how to provide the necessary care.

SCHEDULED CARE

The only care required for the rotary tiller on a regularly scheduled basis is lubrication. The rotary tiller must be lubricated as shown in figures 7 and 8 before the first use and after every 25 hours of operation.

A Maintenance Record (figure 14) is provided to help you document all operating hours and maintenance repair actions.

NORMAL STORAGE

To protect your rotary tiller, store it in an enclosed dry area. Clean the tines and body of the rotary tiller to remove excess dirt and plant matter. This can be done easily with a hose.

OFF-SEASON STORAGE

When the rotary tiller is to be stored for 30 days or more, take precautions as follows:

1. Remove rotary tiller from tractor.
2. Clean the entire tiller, including the tine assemblies.
3. Coat the tines with a light film of grease or oil. Coat all other bare metal surfaces with a good quality paint (obtainable from your dealer) or a light film of grease or oil.
4. Lubricate rotary tiller. (See figure 7.) Check gear box oil level. (See figure 8.)

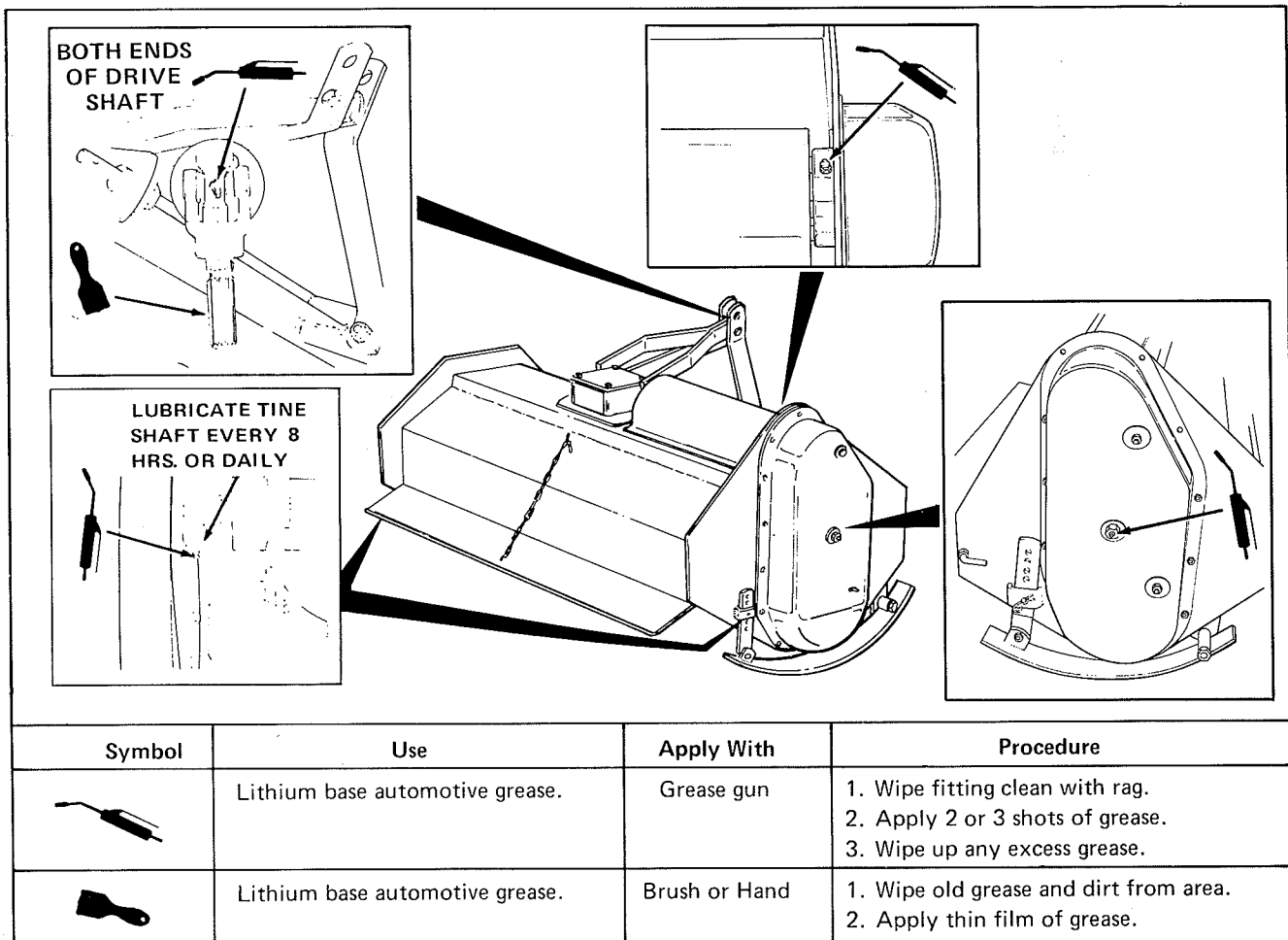

Figure 7. Lubricate Rotary Tiller (Every 25 Hours)

1. Position tiller so top of gear box is level.

2. Remove check plug.

3. Oil level should be up to bottom of check plug hole. If not, remove fill plug and add SAE 90 weight transmission oil. Be sure to install fill plug again.

4. Install and tighten check plug.

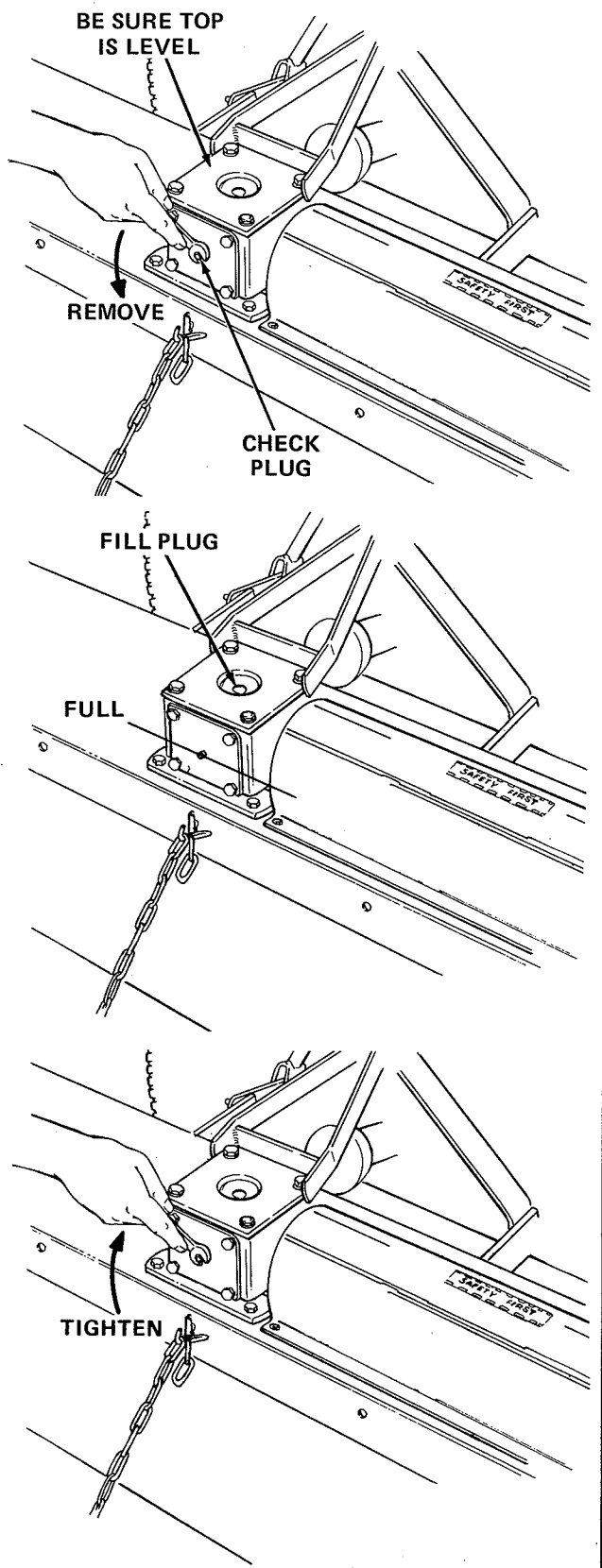

Figure 8. Check Gear Box Oil Level (Every 25 Hours)

Troubleshooting

CONTENT OF SECTION

This section of the manual guides you in troubleshooting some of the more common and easily corrected rotary tiller problems. The same type of data for the tractor can be found in your tractor owner's manual. For problems not covered in these manuals, it is recommended that you contact your dealer.

TROUBLESHOOTING PROCEDURES

Troubleshooting procedures are provided in figure 9. To use these procedures, first locate the problem description that best describes the trouble that you

have encountered. Check the possible causes one at a time in the order that they are listed. Correct any problems that are found and try to operate the rotary tiller again to see if you have eliminated the trouble.

WARNING

For your safety, do not try to adjust or repair the tractor or rotary tiller while the engine is running. Lower tiller to the ground. Also, always remove the key from the ignition switch before beginning the maintenance to prevent accidental starting of the engine.

Problem	Cause/Remedy
1. Rotary tiller tines do not rotate.	<ul style="list-style-type: none"> A. Rear PTO not engaged. Set REAR CLUTCH switch to its on position. B. Tiller clutch slipping. Check tines and remove any wire, etc. that is binding tines. If problem persists, adjust slip clutch. C. Drive chain broken. Replace it. D. Rear PTO clutch will not engage. Check for loose wires.
2. Tills too shallow.	<ul style="list-style-type: none"> A. Tiller being lifted. Place rear lift control in float position. B. Skid shoes set wrong. Raise skid shoes. C. Engine speed too slow. Set engine for 3/4 to full speed. D. Tractor speed too fast. Use slower speed. E. Ground too hard. Make several passes, tilling deeper on each pass.
3. Tiller leaves ground rough with large clods.	<ul style="list-style-type: none"> A. Ground too wet. Wait until soil does not ball up. B. Tilling too deep at one pass. C. Tractor speed too fast. Set transmission gear shift for slower speed.
4. Tractor handles poorly.	<ul style="list-style-type: none"> A. Tractor speed too fast. Use slower speed, especially when running on rough or sloping surfaces. B. Front wheels lifting. Use front counterweight. C. Rear wheels slip. Use rear wheel weights.

Figure 9. Troubleshooting Procedures

TINE REPLACEMENT

When required because of wear or breakage, replace a tine as follows:

1. Remove two capscrews (item A, figure 10) and locknuts (item B).
2. Remove old tine (item C) from tiller.
3. Place new tine on mounting plate (item D). Be sure tine curves away from mounting plate with its sharp edge facing rearward when tine nears bottom of travel.
4. Insert two capscrews (item A) through tine and then through mounting plate. Install and tighten locknuts (item B) to a torque of 40 foot-pounds (54 N-m).

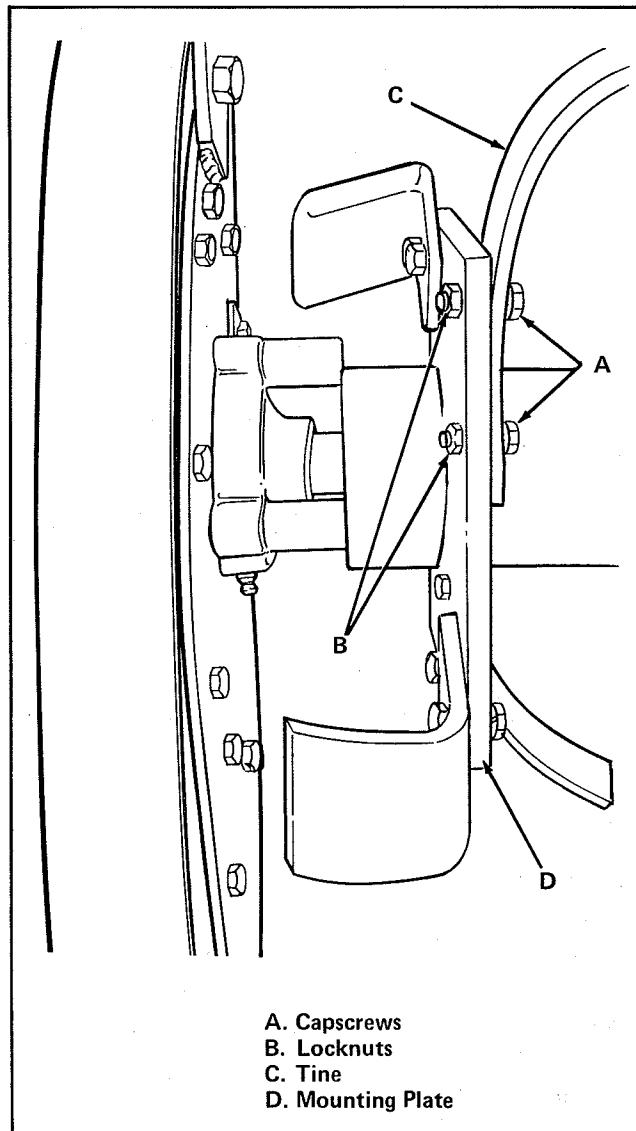

Figure 10. Tine Replacement

CHAIN REPLACEMENT

When a chain breaks or becomes so loose that the chain tension adjustment cannot be performed, replace the chains as follows:

1. Remove three nuts, one with grease fitting, from center of chain cover (figure 11).
2. Remove 12 locknuts around outer edge of chain cover. Then remove chain cover, taking care to prevent damage to gasket (item A).
3. Remove both chains (items D and E).
4. Clean all old grease from sprockets, tiller end plate, and chain cover.
5. Check rollers (item B) and gasket (item A). Replace these items if they are worn or damaged. Also be sure that three setscrews (item C) are tight.
6. Install new drive chains. The shorter chain (item D) must be installed first.
7. Cover drive chains with a thick coating of general purpose automotive grease. Pack about 2 pounds (1 kg) of this grease in bottom of chain cover.
8. Install chain cover and secure it by installing and tightening the 12 locknuts around the cover edges.
9. Install and tighten stud with grease fitting in center hole of chain cover.
10. Install large flat washers and nuts on the two chain roller capscrews protruding through chain cover. Finger tighten nuts. Then perform chain tension adjustment. (See Adjustment Section.)

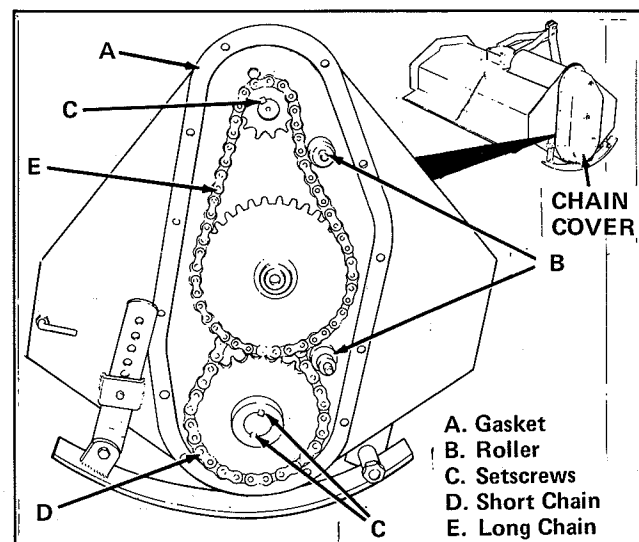

Figure 11. Chain Replacement

Adjustments

CONTENT OF SECTION

This section tells you how to adjust the rotary tiller to keep it operating efficiently. Normally, the adjustment procedures should be performed only to correct problems.

WARNING

To avoid serious injury, perform adjustment procedures only when the tractor engine is stopped. Always remove the ignition key before beginning the adjustment procedures to prevent accidental starting of the engine. Be sure tiller is lowered to the ground.

ADJUSTMENT PROCEDURES

Chain Tension

The capscrews which hold the chain tension rollers are mounted in slots (item B, figure 12). Because the rollers wear with use, the capscrew positions must be adjusted to maintain chain tension. Once a year, or more often if the tiller is used for com-

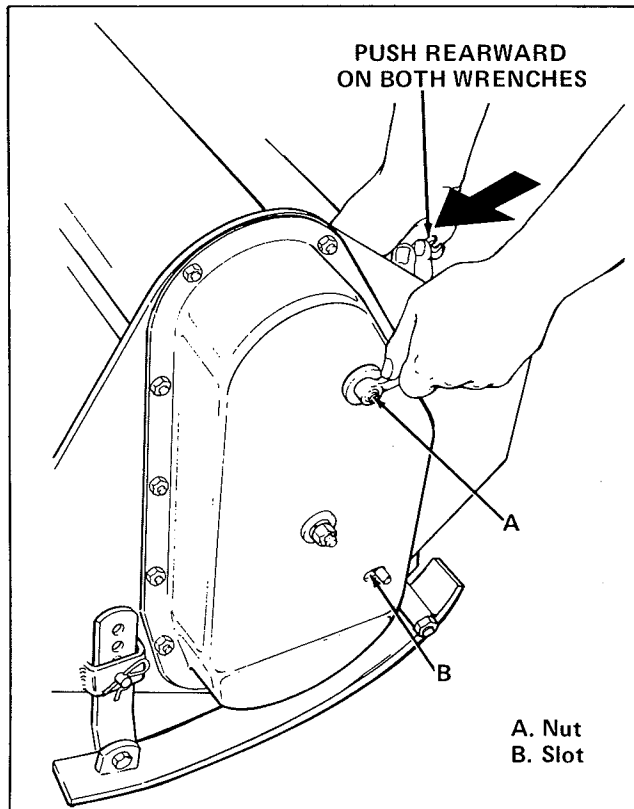

Figure 12. Chain Tension Adjustment

mercial purposes, adjust the chain tension as follows:

1. Loosen, but do not remove, nut (item A).
2. Use two box wrenches as shown to hold the nut and its capscrew. Push both box wrenches to the rear as you retighten the nut.
3. Repeat steps 1 and 2 at the nut over the slot (item B).

Slip Clutch

The slip clutch must drive the tiller during normal operation. Yet, it must be adjusted so it slips whenever the tines strike hard objects. By slipping, the clutch prevents damage to the tiller drive and PTO. When the slip clutch becomes too hot to touch from slippage during normal operation, re-adjust the clutch as follows:

NOTE

Do not overtighten the slip clutch. If the clutch is too tight, it cannot protect the tiller drive and PTO.

1. Remove six screws that secure crossdrive shaft cover (figure 13). Then remove cover.
2. Hold capscrew (item A) while tightening locknut (item B). Tighten locknut only until spring is fully compressed. That is, until the locknut suddenly becomes harder to turn.
3. Repeat step 2 to tighten the other five locknuts.
4. Hold capscrew while loosening each locknut (item B) exactly one-half turn.
5. Reinstall drive shaft cover on tiller. Secure it by installing and tightening the six screws removed in step 1.

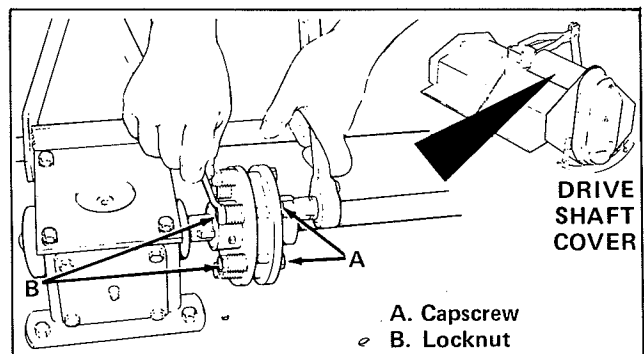

Figure 13. Slip Clutch Adjustment

Maintenance Record

Date	Hours Used	Lubrication	Maintenance/Repair

Figure 14. Maintenance Record

Specifications

DIMENSIONS	Tilling Depth	8 Inches (203 mm) Maximum
	Effective Width	48 Inches (1.2 m)
	Net Weight	305 Pounds (139 kg)
CONTROLS	Tine Drive	Rear PTO Clutch Switch
	Raise and Lower	Hydraulic Rear Lift Control
DRIVE TRAIN	Clutch	Tractor PTO, Electrically Operated
	Input Drive	Double Universal Joint Drive Shaft
	Intermediate Drive	Bevel Gears, Cross Shaft with Slip Clutch
	Final Drive	Double Reduction Roller Chains
CHASSIS	Bearings	Rolling Contact with Grease Fittings
	Tine Shaft Speed	200 rpm at Full Engine Speed
	Number of Tines	28 Replaceable Tines

