



ATTO Technology, Inc.

Installation and Operation Manual

ATTO ExpressPCI FC 3321

Dual channel 2-Gigabit FC-to-PCI Host Adapter, SW optical LC SFF interface

ATTO ExpressPCI FC 3322

Dual channel 2-Gigabit FC-to-PCI-X Host Adapter, SW optical LC SFP interface

ATTO ExpressPCI FC 3342

Quad channel 2-Gigabit FC-to-PCI-X Host Adapter, SW optical LC SFP interface

© 2003 ATTO Technology, Inc. All rights reserved. All brand or product names are trademarks of their respective holders. No part of this manual may be reproduced in any form or by any means without the express written permission of ATTO Technology, Inc.

Contents

| | |
|---|-----------|
| 1 ATTO provides Fibre Channel solutions | 1 |
| ATTO ExpressPCI FC 3321 | |
| Fibre Channel Interface | |
| Advanced FC features | |
| Advanced SCSI-FCP support | |
| Exclusive Advanced Data Streaming (ADS TM) Technology | |
| Accelerated PCI bus management | |
| Environmental & physical specifications | |
| ATTO ExpressPCI FC 3322 | |
| Fibre Channel Interface | |
| Advanced FC Features | |
| Advanced SCSI-FCP Support | |
| Exclusive Advanced Data Streaming (ADS TM) Technology | |
| Accelerated PCI Bus Management | |
| Environmental & Physical Specifications | |
| ATTO ExpressPCI FC 3342 | |
| Fibre Channel Interface | |
| Advanced FC Features | |
| Advanced SCSI-FCP Support | |
| Exclusive Advanced Data Streaming (ADS TM) Technology | |
| Accelerated PCI Bus Management | |
| Environmental & Physical Specifications | |
| 2 Fibre Channel is a key technology for storage | 5 |
| Glossary | |
| 3 Hardware installation and initial configuration | 7 |
| System requirements | |
| Fibre Channel address | |
| Installation | |
| LEDs | |
| Cabling | |
| ExpressPCI FC 3321 | |
| ExpressPCI FC 3322 | |
| ExpressPCI FC 3342 | |
| Initial configuration | |
| 4 Installing/updating device drivers and firmware | 11 |
| Windows 2000/XP driver installation | |
| Windows NT driver installation | |
| Mac OS X driver installation/update | |
| Re-flashing firmware | |
| Linux and Sun Solaris driver installation | |
| 5 Troubleshooting | 13 |
| General suggestions | |
| Windows 2000 | |
| Windows NT | |

| | |
|---|------------|
| Appendix A Standards and compliances | i |
| Appendix B Fibre Channel accessories | ii |
| Appendix C SCSI host adapter selection guide | iii |
| Appendix D Contact ATTO Technology, Inc. | iv |

1 ATTO provides Fibre Channel solutions

ATTO ExpressPCI FC host adapters have been designed to ensure interoperability with Fibre Channel devices and compatibility with a broad range of servers and workstations to meet your needs.

ATTO ExpressPCI FC 3321

The ATTO ExpressPCI FC 3321 host adapter incorporates dual independent channels with 2-Gigabit Fibre Channel performance on a single low-profile Fibre Channel host adapter. The ATTO ExpressPCI FC 3321 is designed to support data-intensive applications while using only one PCI slot, representing a cost-effective and efficient choice for Enterprise and Workstation applications. It supports high-performance applications, including Digital Video/Audio, Imaging/Fixed Content and Backup/Archiving.

Fibre Channel Interface

- ❖ 2.125 Gigabit data transfer rates on each channel
- ❖ 400 MB/sec. per channel, full duplex
- ❖ Auto negotiation between 1-Gigabit and 2-Gigabit speeds
- ❖ Short-wave optical LC SFF connectors
- ❖ Supports all Fibre Channel topologies
 - Point to point
 - Arbitrated loop
 - Switched fabric (FL-port, F-port)
- ❖ Strict adherence to ANSI specifications: FC-PH, FC-AL2, FC-FCP, FC-PLDA, FC-FLA, FCA-IP, iETF-iPFC, FC-Tape
- ❖ Supports Class 2 and Class 3 transfers.
- ❖ LED indicates link activity, on line and fault status for each channel
- ❖ Flash ROM for easy field upgrades

Advanced FC features

- ❖ Support for SNIA HBA API
- ❖ LUN masking
- ❖ Supports target and initiator modes

Advanced SCSI-FCP support

- ❖ Large command FIFO
- ❖ Asynchronous I/O support
- ❖ ASPI and SCSI Manager 4.3 compatible
- ❖ Bootable from attached disks
- ❖ Support for multiple block sizes

Exclusive Advanced Data Streaming (ADS™) Technology

- ❖ Improved PCI system bandwidth use
- ❖ Optimized FC and SCSI-3 algorithms
- ❖ Supports SCSI-3 tagged command queuing
- ❖ RISC processor for high performance

Accelerated PCI bus management

- ❖ PCI Bus Master DMA
- ❖ PCI 2.2 and PCI 99 compliant
- ❖ 64-bit/66 MHz PCI (backward compatible with standard 32-bit and 33MHz busses)

Environmental & physical specifications

- ❖ Temperature: 0-50°C
- ❖ Humidity: 5-90% non-condensing
- ❖ Low profile dimensions
 - Height: 2.53"
 - Width: 6.6"
- ❖ Low profile and full height brackets available
- ❖ MTBF: >250,000 hours
- ❖ MTTR: <15 minutes
- ❖ Power requirements:
 - 1.5 Amp max @ 5.0 Volts
- ❖ Airflow: 100 LFM (min.)
- ❖ PCI signal compatibility:
 - 3.3V/5V universal

ATTO ExpressPCI FC 3322

The ATTO ExpressPCI FC 3322 host adapter incorporates dual independent channels of 2-Gigabit Fibre Channel performance on a single, low-profile host adapter. Its low-profile design facilitates flexibility and maximum performance in high-density environments. It supports high-performance applications, including Digital Video/Audio, Imaging/Fixed Content and Backup/Archiving.

Fibre Channel Interface

- ❖ 2.125-Gigabit data-transfer rates on each channel
- ❖ 400 MB/sec. per channel, full duplex
- ❖ Auto negotiation between 1-Gigabit and 2-Gigabit speeds
- ❖ Short-wave optical LC SFP connectors
- ❖ Supports all Fibre Channel topologies
 - Point to Point
 - Arbitrated loop
 - Switched fabric (FL-port, F-port)
- ❖ Strict adherence to ANSI specifications: FC-PH, FC-AL2, FC-FCP, FC-PLDA, FC-FLA, FCA-IP, iETF-iPFC, FC-Tape
- ❖ Supports Class 2 and Class 3 transfers
- ❖ LEDs indicate link activity, on line and fault status for each channel
- ❖ Flash ROM for easy field upgrades

Advanced FC Features

- ❖ Support for SNIA HBA API
- ❖ LUN Masking
- ❖ Supports target and initiator modes

Advanced SCSI-FCP Support

- ❖ Large command FIFO
- ❖ Asynchronous I/O support
- ❖ ASPI compatible
- ❖ Bootable from attached disks
- ❖ Support for multiple block sizes

Exclusive Advanced Data Streaming (ADS™) Technology

- ❖ Improved PCI system bandwidth use
- ❖ Optimized FC and SCSI-3 algorithms
- ❖ Supports SCSI-3 tagged command queuing
- ❖ RISC processor for high performance

Accelerated PCI Bus Management

- ❖ PCI bus master DMA
- ❖ PCI 2.2 and PCI 99 compliant
- ❖ 64-bit/133 MHz PCI-X

Environmental & Physical Specifications

- ❖ Temperature:0-50°C
- ❖ Humidity:5-90% non-condensing
- ❖ Low-profile dimensions:
 - Height: 2.53"
 - Width: 6.521"
- ❖ MTBF:>250,000 hours
- ❖ MTTR:<15 minutes
- ❖ Airflow:100 LFM (min)
- ❖ Power Requirements:
 - 2.0 Amps max @ 3.3 Volts
 - 5.0 Amps max @ 5.0 Volts
- ❖ PCI Signal Compatibility:
 - 3.3V/5V universal

ATTO ExpressPCI FC 3342

The ATTO ExpressPCI FC 3342 host adapter, with four independent 2-Gigabit FC ports and delivering data-transfer rates up to 400 MB/second per channel, provides the ultimate performance for the most demanding data environments. It is ideal for connecting servers directly to multiple storage sub-systems for advanced, aggregated performance, while still conserving valuable PCI expansion slots. It supports high-performance applications, including Digital Video/Audio, Imaging/Fixed Content and Backup/Archiving.

Fibre Channel Interface

- ❖ 2.125-Gigabit data-transfer rates on each channel
- ❖ 400 MB/sec. per channel, full duplex
- ❖ Auto negotiation between 1-Gigabit and 2-Gigabit speeds
- ❖ Short-wave optical LC SFP connectors
- ❖ Supports all Fibre Channel topologies
 - Point to Point
 - Arbitrated loop
 - Switched fabric (FL-port, F-port)
- ❖ Strict adherence to ANSI specifications: FC-PH, FC-AL2, FC-FCP, FC-PLDA, FC-FLA, FCA-IP, iETF-iPFC, FC-Tape
- ❖ Supports Class 2 and Class 3 transfers
- ❖ LEDs indicate link activity, on line and fault status for each channel
- ❖ Flash ROM for easy field upgrades

Advanced FC Features

- ❖ Support for SNIA HBA API
- ❖ LUN Masking
- ❖ Supports target and initiator modes

Advanced SCSI-FCP Support

- ❖ Large command FIFO
- ❖ Asynchronous I/O support
- ❖ ASPI compatible
- ❖ Bootable from attached disks
- ❖ Support for multiple block sizes

Exclusive Advanced Data Streaming (ADS™) Technology

- ❖ Improved PCI system bandwidth use
- ❖ Optimized FC and SCSI-3 algorithms
- ❖ Supports SCSI-3 tagged command queuing
- ❖ RISC processor for high performance

Accelerated PCI Bus Management

- ❖ PCI bus master DMA
- ❖ PCI 2.2 and PCI 99 compliant
- ❖ 64-bit/133 MHz PCI-X

Environmental & Physical Specifications

- ❖ Temperature:0-50°C
- ❖ Humidity:5-90% non-condensing
- ❖ Low-profile dimensions:
 - Height: 4.2"
 - Width: 6.875"
- ❖ MTBF:>100,000 hours
- ❖ MTTR:<15 minutes
- ❖ Airflow:100 LFM (min)
- ❖ Power Requirements:
 - 1.0 Amps max @ 3.3 Volts (max)
 - 4.5 Amps max @ 5 Volts (max)
- ❖ PCI Signal Compatibility:
 - 3.3 Volts only

Fibre Channel host adapter selection guide

| | 2-Gigabit Adapters | | | | |
|-------------------------------|----------------------------|----------------------------|----------------------------|----------------------------|-------------------------|
| | FC 3342 | FC 3322 | FC 3321 | FC 3300 | FC 3305 |
| Fibre Channel ports | 4 | 2 | 2 | 1 | 1 |
| Optical interface | SW, LC, SFP | SW, LC, SFP | SW, LC, SFF | Fixed SW LC | |
| Copper interface | | | | | HSSDC |
| Max. transfer rate | 400 MB/sec per channel | 400 MB/sec per channel | 400 MB/sec per channel | 400 MB/sec | 400 MB/sec |
| Class transfers | 2, 3 | 2, 3 | 2, 3 | 2, 3 | 2, 3 |
| Full duplex | ✓ | ✓ | ✓ | ✓ | ✓ |
| 66/33 MHz PCI compatible | 66 MHz only | ✓ | ✓ | ✓ | ✓ |
| 133 MHz PCI-X compatible | ✓ | ✓ | | | |
| 64- and 32-bit PCI compatible | 64-bit only | ✓ | ✓ | ✓ | ✓ |
| Windows® XP/2000/NT | ✓ | ✓ | ✓ | ✓ | ✓ |
| Windows Server 2003 | ✓ | ✓ | ✓ | ✓ | ✓ |
| Solaris/Linux | | Linux | Linux | ✓ | ✓ |
| Mac OS X | | | Mac OSX | ✓ | ✓ |
| Mac OS 9 | | | | ✓ | ✓ |
| RAID support | | | Mac OSX | ✓ | ✓ |
| Maximum cable length | 300m @ 2-Gb 500m @ 1-Gb | 300m @ 2-Gb 500m @ 1-Gb | 300m @ 2-Gb 500m @ 1-Gb | 300m @ 2-Gb 500m @ 1-Gb | 25 m (175m with MIA) |

2 Fibre Channel is a key technology for storage

Fibre Channel is a serial communications technology designed to transfer large amounts of data among a variety of hardware systems over long distances. It is a key technology for applications that require shared, high bandwidth access to storage.

Fibre Channel provides a logical, point-to-point, serial channel for the transfer of data between a buffer at a source device and a buffer at a destination device. It moves buffer contents from one port to another, without regard to the format or meaning of the data so different upper level protocols are able to run over Fibre Channel hardware.

The Fibre Channel architecture is structured as a hierarchical set of protocol layers. Defined within these layers are rules for signal interfaces, serial encoding and decoding, error control, frame format and communications protocols.

ATTO ExpressPCI Fibre Channel host adapters carry SCSI protocol over Fibre Channel.

Glossary

Some terms used in the Fibre Channel industry are defined below. More information is available through the ATTO Technology website (www.attotech.com), the Fibre Channel Industry Association (www.fibrechannel.com), Cern (www.cern.ch), the Storage Area Networking Industry Association (www.snia.org), and the Fibre Channel Consortium (www.iol.unh.edu/consortiums, click on FC).

| Term | Definition |
|---------------------|---|
| ANSI | American National Standards Institute |
| arbitrate | process of selecting one L_Port from a collection of ports which ask for use of the arbitrated loop at the same time |
| arbitrated loop | a loop topology (FC-AL) in which two or more ports are interconnected, but only two ports can communicate at one time; low-cost solution which may or may not use hubs and switches |
| auto negotiation | hardware senses and automatically responds depending on configuration |
| BER | Bit Error Rate: a measure of transmission accuracy; the ratio of bits received in error to bits sent |
| bit | Smallest unit of data a computer can process: a single binary digit with a value of either 0 or 1 |
| bus | a collection of unbroken signal lines used to transmit information from one part of a computer system to another; taps on the lines connect devices to the bus |
| Byte | an ordered set of 8 bits |
| channel | a point-to-point link which transports data from one point to another |
| CPU | Central Processing Unit: the portion of the computer that actually performs computations |
| CRC | Cyclic Redundancy Check: an error-correcting code which calculates a numeric value for received and transmitted data; if no error has occurred during transmission, the CRC for both received and transmitted data should be the same |
| destination address | a value in the frame header of each frame which identifies the port in the node where the frame is being sent |
| device driver | a program that allows a microprocessor to direct the operation of a peripheral device |
| DMA | Direct Memory Access: a way to move data from a storage device directly to RAM without using the CPU's resources |
| DMA bus master | Allows a peripheral to control the flow of data to and from system memory by block as opposed to allowing the processor to control the data by bytes (PIO or programmed I/O) |

| Term | Definition |
|-------------------|---|
| fabric | A Fibre Channel switch or two or more Fibre Channel switches interconnected to physically transmit data between any two N_Ports on the switch or switches |
| FC | Fibre Channel |
| F_port | A port in the Fibre Channel fabric where a N_port may attach |
| FL_port | A port in the Fibre Channel fabric where a NL_port may attach in an arbitrated loop |
| frame | an indivisible unit for transfer of information in Fibre Channel |
| frame header | the first field in the frame containing the address and other control information about the frame |
| full duplex | a communication protocol which allows transmission in both directions at the same time |
| half duplex | a communication protocol which allows transmission in both directions, but only one direction at a time |
| host | a processor, usually a CPU and memory, which communicates with devices over an interface |
| initiator device | A component which originates a command |
| L_port | a port in an arbitrated loop, either a NL_port or a FL_port |
| LED | Light-emitting diode: a type of diode that emits light when current passes through it; visible LEDs are used as indicator lights on all sorts of electronic devices |
| LUN | Logical Unit Number: an identifier for a logical unit (0-7) |
| multi-mode fiber | an optical fiber which can carry several beams of light at once |
| N_port | a port attached to a node used with point to point or fabric configurations |
| NL_port | a port attached to a node in Fibre Channel arbitrated loop or fabric loop configuration |
| originator | an initiating device; a component which originates a command |
| parity checking | A method which verifies the accuracy of data transmitted over the SCSI bus by adding one bit in the transfer to make the sum of all the bits either odd or even (for odd or even parity); an error message occurs if the sum is not correct |
| PCI | Peripheral Component Interconnect. Allows peripherals to be connected directly to computer memory, bypassing the slower ISA and EISA busses |
| point-to-point | a topology where two ports communicate |
| port | an access point in a device: see N_port, NL_port, etc. |
| port address | also port number; the address, assigned by the PCI bus, through which commands are sent to a host adapter board |
| port number | see port address |
| receiver | the ultimate destination of data transmission; a terminal device |
| scatter/gather | a device driver feature which allows the host adapter to modify a transfer data pointer so that a single host adapter can access many segments of memory, minimizing interrupts and transfer overhead |
| SCSI | Small Computer Systems Interface: a processor-independent standard for system-level interface between a computer and intelligent devices including hard disks, floppy disks, CD-ROM, printers, scanners, etc. |
| single-mode fiber | an optical fiber with a small core which supports one wavelength (ray of light); the core radius is nearly equal to the wavelength of the source |
| topology | logical layout of the parts of a computer system or network and their interconnections |
| transceiver | a transmitter/receiver module |
| transfer rate | the rate at which bytes or bits are transferred, as in megabytes or gigabits per second |

3 Hardware installation and initial configuration

You will need a basic understanding of Fibre Channel before installing the ATTO ExpressPCI host adapter. Please refer to Chapter 2 for a list of Fibre Channel-related web sites.

WARNING ATTO Technology recommends that you back up your system data before changing or installing any hardware.

System requirements

The ATTO ExpressPCI host adapter package contains the host adapter, the ATTO Express Pro-Tools CD and a warranty and registration card. If any of these items are missing, contact your ATTO authorized sales representative.

To install and use the ATTO ExpressPCI Fibre Channel adapter you will need:

- ❖ A computer with an available PCI or PCI-X expansion slot.
- ❖ The complete ATTO ExpressPCI FC host adapter package.

Fibre Channel address

ATTO ExpressPCI host adapters are configured with a unique address designated by the Institute of Electrical and Electronic Engineers. The WorldWide Port Name (WWN) and Node name are the two components of the address assigned to Fibre Channel products. This address, which is stored in the NVRAM on the ATTO ExpressPCI host adapter, allows the system to recognize it as a unique part of your configuration. The address is clearly marked on the back of the board for easy identification. Please keep a reference copy of the number in a safe place or write in the space provided below.

ExpressPCI FC host adapter WWNs are assigned for each channel. The WWN listed on your host adapter is assigned to the first channel (0). Sequential WWNs apply for additional channels.

- WWN 0: _____
- WWN 1: _____
- WWN 2: _____ (FC 3342 only)
- WWN 3: _____ (FC 3342 only)

Installation

WARNING ATTO ExpressPCI host adapters contain components that are sensitive to electrostatic discharge (ESD). ESD can cause damage to the ExpressPCI host adapter. Please follow standard methods to avoid ESD.

- 1 **Power down the computer and unplug the computer from all power sources.**
- 2 **Open the case.**
- 3 **Install the ATTO ExpressPCI host adapter in any open PCI expansion slot. If you have questions about how to install an expansion card in your system, consult your computer's documentation.**

Exhibit 3-1 Inserting the host adapter

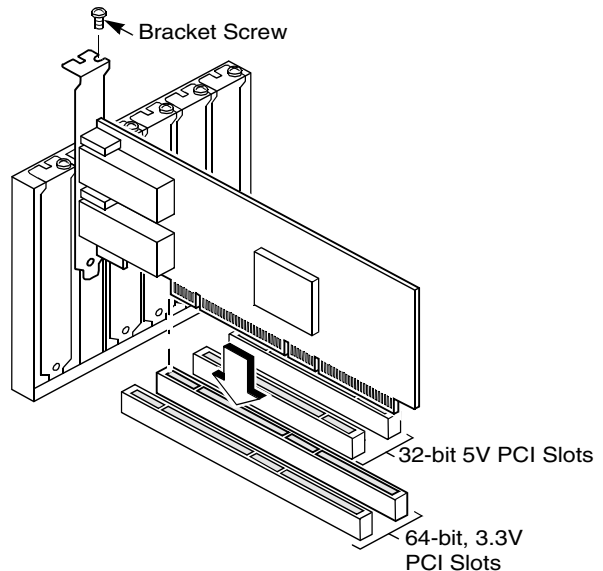

Note: If you have difficulty seating the ATTO ExpressPCI host adapter in 32-bit PCI bus computers, check to make sure the connector can accommodate 64-bit host adapters. FC 3342 host adapters will only fit in 3.3V slots.

- 4 **Connect Fibre Channel devices by inserting a Fibre Channel cable to the connector on the ATTO ExpressPCI host adapter until you hear a click.**
- 5 **Close the case on the computer and power it up.**

ExpressPCI FC 3321

The ATTO ExpressPCI FC 3321 has two SFF duplex LC optical connectors and uses a short wave laser. A multi-mode cable must be used with short wave lasers. For best performance you should use 50 micron multi-mode optical cables. Cable length should be no more than 500 meters.

ExpressPCI FC 3322

The ATTO ExpressPCI FC 3322 has two pluggable SFP LC optical connectors and uses a short wave laser. A multi-mode cable must be used with short wave lasers. For best performance you should use 50 micron multi-mode optical cables. Cable length should be no more than 500 meters.

ExpressPCI FC 3342

The ATTO ExpressPCI FC 3342 has four pluggable SFP LC optical connectors and uses a short wave laser. A multi-mode cable must be used with short wave lasers. For best performance

you should use 50 micron multi-mode optical cables. Cable length should be no more than 500 meters.

LEDs

Dual-purpose LEDs, one per port and visible through the bracket, indicate activity on the Fibre Channel link. A blinking green LED shows activity on that channel; a yellow LED shows a fault condition.

| Link | Activity | Fault |
|------|----------------|--------|
| Off | Green blinking | Yellow |

Cabling

Fibre Channel technology offers a variety of cabling options including standard copper, equalized copper and fiber optic, depending on the requirements of your environment.

Exhibit 3-2 ExpressPCI FC 3321 bracket and board

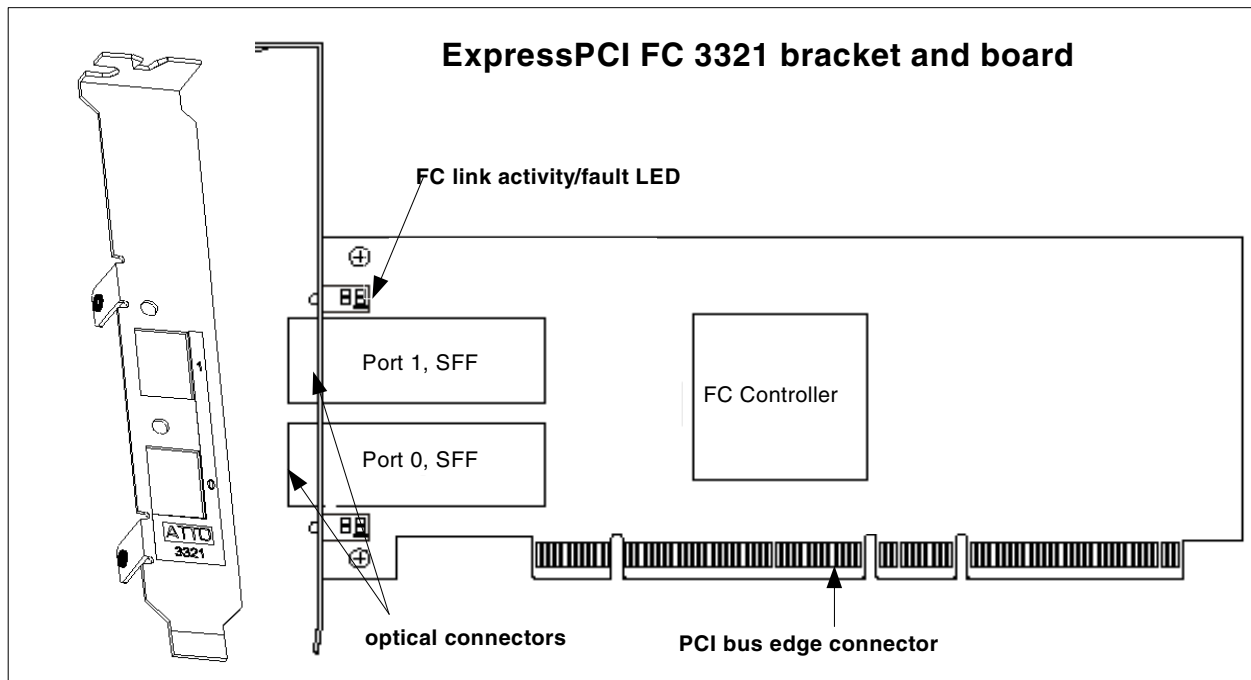

Exhibit 3-3 ExpressPCI FC 3322 bracket and board

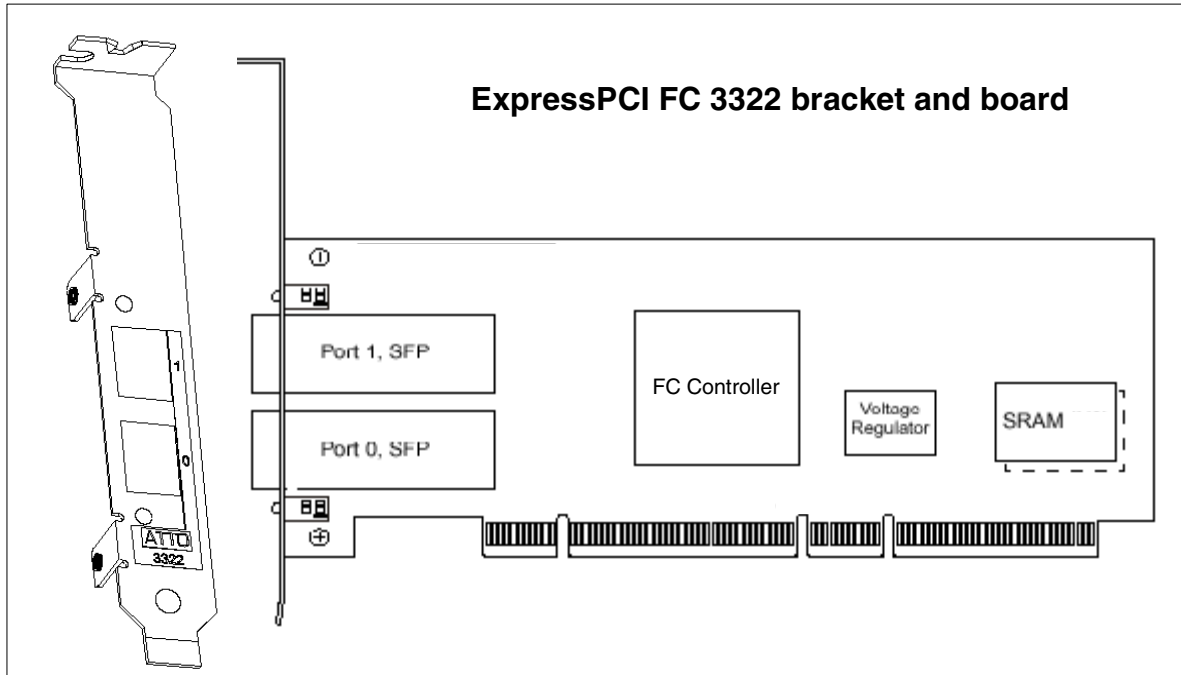
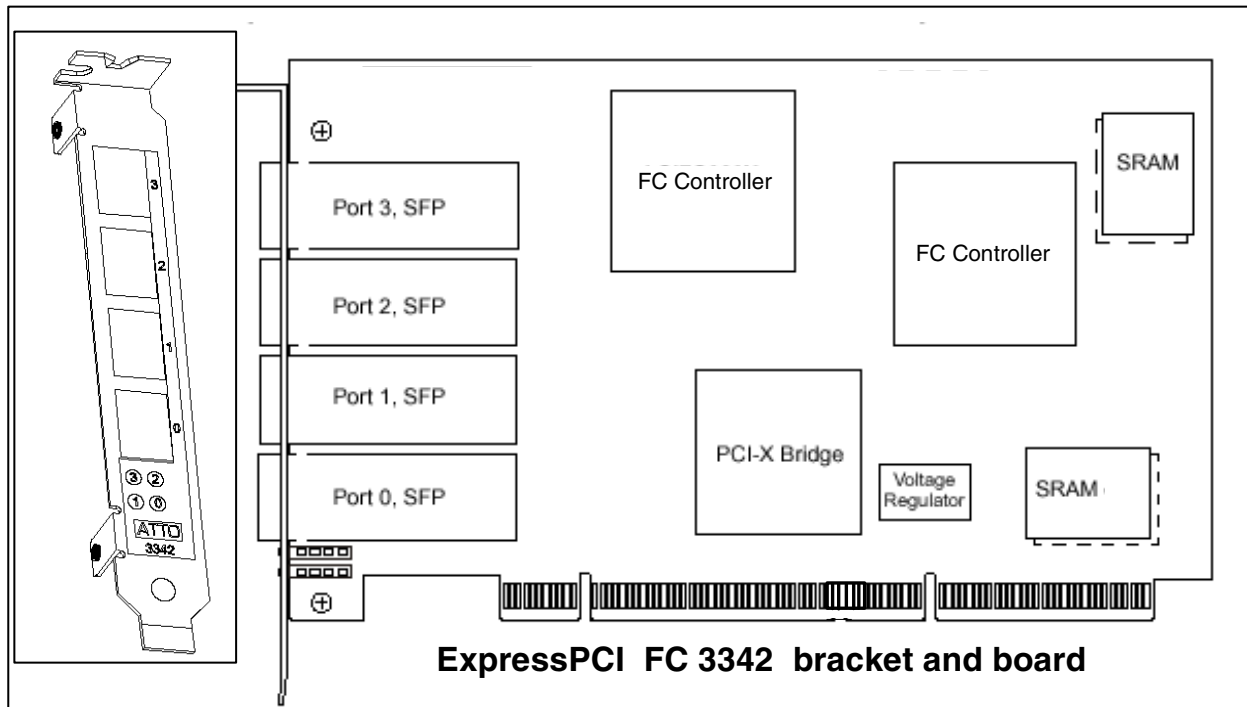

Exhibit 3-4 Express PCI FC 3342 bracket and board



Initial configuration

While the factory settings on your ExpressPCI host adapter should provide excellent performance for a wide range of applications, some specialized applications may benefit from modification of the adapter settings to tune the

adapter for a specific performance range. The *ExpressPCI Utilities Installation and Operation Manual* provides detailed information on using ATTO Technology configuration utilities.

4 Installing/updating device drivers and firmware

ExpressPCI FC host adapters require a device driver and firmware for proper operation. Your adapter firmware was properly flashed before shipment, but the firmware may need to be updated as new versions become available, or if the factory-installed version becomes corrupt. Visit the ATTO website, www.attotech.com, to download the latest drivers and firmware.

ATTO recommends using the same device driver and firmware version. To verify the version:

Windows Use the ATTO ExpressPCI Configuration Tool for complete information about the driver and firmware version or use a combination of the adapter boot string (firmware

version) during system boot and the Device Manager (driver version)

Mac OS X Use the ATTO ExpressPCI Configuration Tool (driver and firmware version available) or Apple System Profiler (driver version only)

Windows 2000/XP driver installation

New installation

- 1 After initial devices have been loaded, press F6. The installer will prompt the user to *Specify Additional Device* by using the *S* option.
- 2 When prompted for vendor's disk, insert the ATTO ExpressPro-Tools CD-ROM, into the drive and press the *ENTER* key.
- 3 Select *ExpressPCI FC* and then press the *ENTER* key.
- 4 Continue the installation of the operating system. The Windows 2000 installation may request the ExpressPCI driver disk again.
- 5 Reboot the system.

Pre-existing installation

- 1 Boot into Windows 2000/XP. The *New Hardware Wizard* window will appear.
- 2 Click *Next*.
- 3 Choose the *Search for a suitable driver for my device* option.
- 4 Insert the ATTO ExpressPro-Tools CD.
- 5 In next window, be sure the CD-ROM is selected as the source for the driver.

- 6 Once the system finds the driver, click the *Next* button.
- 7 Click *Yes* when the system prompts to continue installation.
- 8 Reboot system.

Updating the Windows 2000 driver

- 1 Right-click *My Computer* and select *Properties*.
- 2 Select the *Hardware* tab and select *Device Manager*.
- 3 Right-click the *ATTO ExpressPCI adapter* description, located under *SCSI and RAID controllers*, and select *Properties*.
- 4 Go to the *Driver* tab and select *Update Driver*.
- 5 Select *Next*.
- 6 Choose the *Search for a suitable driver for my device* option.
- 7 Choose the appropriate path to the new driver location.
- 8 Once the system finds the driver, click the *Next* button.
- 9 Click *Yes* when the system prompts to continue installation.
- 10 Reboot system

Windows NT driver installation

New installation

- 1 Begin the Windows NT installation using the Windows NT Installation floppy diskettes.
- 2 During the installation after initial devices have been loaded, press F6. The installer will prompt you to *Specify Additional Devices* by using the *S* option.
- 3 When prompted for vendor's disk, insert the ATTO ExpressPro-Tools CD-ROM into the drive and press the *ENTER* key.
- 4 Select *ExpressPCI FC* and then press the *ENTER* key.

- 5 Continue the installation of the operating system. The Windows NT installation may request the Express FC driver disk again.

Pre-existing installation

- 1 Enter the *Control Panel* on the *Start Menu* under *Settings*.
- 2 Locate and double click on the *SCSI Adapter* icon
- 3 Click on the *Drivers* tab and then the *Add* button.
- 4 When the *Install Driver* screen appears, select *Have Disk*.
- 5 Place the ATTO ExpressPro-Tools CD-ROM into the drive
- 6 Change the path in the *Copy Manufacturers files from* to the appropriate drive.

- 7 Select *ExpressPCI FC* and click *OK*.
- 8 When the driver is finished loading, reboot the system.

Updating the Windows NT driver

- 1 Click on the Start menu and select *Run*.
- 2 Type in *RDISK.EXE* and press *ENTER* to create an emergency repair disk.
- 3 Double-click *My Computer* and open the *Control Panel*.
- 4 Double-click the *SCSI Adapter* icon.

- 5 Click on the *Driver* tab and highlight the *ATTO ExpressFC driver*.
- 6 Click on the *Remove* button to remove the old driver.
- 7 Click on the *Add* button and select *Have Disk*.
- 8 Insert the ATTO ExpressPro-Tools CD-ROM.
- 9 Enter the appropriate path to the drive
- 10 If prompted, select a *New* installation of the driver. Do not select *Current* installation.
- 11 Reboot your system.

Mac OS X driver installation/update

New or previous installation

- 1 Download the appropriate version of the device driver from the ATTO web site at www.attotech.com.
- 2 Extract the file to your desktop.
- 3 Double click the installer icon and follow the on screen prompts

- 4 Reboot your system for the changes to take effect.
- 5 Current device driver version can be verified using the ATTO ExpressPCI Configuration Tool. Refer to the ExpressPCI Utilities Operation and Installation Manual for additional information.

Re-flashing firmware

To re-flash firmware in Windows or Mac OS X using the ATTO ExpressPCI Configuration

Tool:

- 1 Download the most recent version of the Configuration Tool from the ATTO web site at www.attotech.com.
- 2 Download the proper flash bundle (these are adapter specific) from the ATTO web site
- 3 Extract these files to your desktop and install the Configuration Tool on your system.
- 4 Launch the Configuration Tool.
- 5 In the *Device window*, select the adapter that needs to be updated.
- 6 In the *Flash window*, click on the *Browse* button to find the flash bundle that you previously downloaded to your desktop.
- 7 Click *Update* to update your flash
- 8 Reboot your system for the firmware changes to take effect
- 9 Refer to the ExpressPCI Utilities Operation and Installation Manual for additional information on using the Configuration Tool

To re-flash firmware on a PC using the BIOS utilities:

- 1 Obtain the latest firmware from the ATTO web site www.attotech.com and extract it to a floppy disk by executing the self-extracting file.
- 2 Reboot the PC.
- 3 During the reboot process, an ATTO Technology banner will announce that the host adapter was detected. Enter *Control-F* when prompted to begin the set-up utility. This must be done within a few seconds after the banner appears, or you will not be able to enter the utility. If this happens, simply repeat step 3.
- 4 In the utility, select the *Upgrade Flash ROM* option and insert the disk into the drive slot.
- 5 Follow the on-screen instructions.
- 6 Remove the disk and reboot your system for the firmware changes to take effect

Note: Firmware must be loaded from a floppy because the CD-ROM drivers are not loaded at this point in the system boot process.

Linux and Sun Solaris driver installation

ATTO offers Linux and Sun Solaris drivers which are compatible with ExpressPCI host adapters. A complete download package, including all necessary installation instructions, is available on the ExpressPro-Tools CD-ROM or directly from

the ATTO web site. Please refer to these documents for installation instructions.

5 Troubleshooting

This chapter contains solutions for the most common problems you might encounter. If you need additional assistance, please refer to the ATTO Technology web site (www.attotech.com) or contact an ATTO Technology authorized representative.

General suggestions

- ❖ Check each cable connection on every device. Verify all cables are in proper working condition. Loose or broken cables are often the cause of errors or problems.
- ❖ Check that your Fibre Channel devices are plugged into an AC outlet and are turned on before you add power to your computer.
- ❖ If using an MIA, check to see it is operating properly.

If the devices connected to the ATTO

ExpressPCI host adapter are not accessible:

- 1 **Right-click *My Computer* and select *Properties*.**
- 2 **Select the *Hardware* tab and select *Device Manager*.**
- 3 **If the ATTO ExpressPCI host adapter does not appear under the SCSI and RAID controllers, shut down and make sure the ATTO ExpressPCI host adapter is properly seated in the PCI slot (remove power from the PC, remove its case, check the PCI slot, replace the case, apply power).**
- 4 **Reload the driver.**
- 5 **If the adapter has been identified but there is an exclamation point (!) on the listing, right click on the listing and select *Uninstall*. Reboot system and repeat the installation process. If problems persist, contact your authorized ATTO Technology representative.**

- ❖ If the card has been recently re-flashed with new firmware, the new Windows driver must be installed. Follow the procedure in Chapter 4.
- ❖ All of the external devices connected to the host adapter should be identified. If they do not appear in the *Device Manager*, the external devices or connection may not be working properly.

- ❖ For Intel-based PCs, check the computer CMOS setup and verify that the PCI slots are configured correctly. Procedures vary greatly: refer to the manual supplied with your system or call the computer supplier for configuration assistance. Windows 2000 is a Plug-n-Play OS: be sure your computer's BIOS is set accordingly.
- ❖ If these do not solve the problem, re-flash the host adapter and re-install the Windows 2000 driver.

Windows NT

- ❖ If using an Intel-based PC, Fibre Channel drives should be booted up before the host computer. If the PC is powered up before the drives, the drives may not be visible to Windows NT.

If the devices connected to ATTO ExpressPCI host adapter are not accessible:

- 1 **Open the *SCSI Adapters* utility in the *Control Panel* under *Settings*.**
- 2 **Verify the ATTO ExpressPCI host adapter 64-bit PCI Fibre Channel host adapter appears under the *Devices List*.**
- 3 **If it does not appear in the *Device List*, verify that the adapter is seated properly in the PCI slot (remove power from the PC, remove its case, check the PCI slot, replace the case, apply power).**
- 4 **If it has been identified, click on the *Drivers Tab* to see if the ATTO ExpressPCI host adapter driver has been started. It will say *Started* in the right hand column of the window. If the ATTO ExpressPCI host adapter driver appears but is not started, check on the device status. In the *Control Panel* click on *Devices* and scroll down to *expresfc*. Click *Startup* button. **Startup type should be *Boot*. Click on *Hardware profiles*, status should be *Enabled*.****

- 5 **If *ExpressPCI FC* does not appear in the *Device List*, try reloading the driver software as described in Chapter 4 of this manual.**
- 6 **If it is started, go back to the *Devices* tab of the SCSI adapters utility window and double click on the ATTO ExpressPCI host adapter description, and then on the bus it is assigned to. All of the external devices connected in the loop should be identified. If they do not appear in the *Device List*, the external devices or connection are not working properly.**
 - ❖ If the card has been recently re-flashed with new firmware, the new NT driver must be installed.
 - ❖ For Intel-based PCs, check the computer CMOS setup and verify that the PCI slots are configured correctly. Procedures vary greatly: refer to the manual supplied with your system or call the computer supplier for configuration assistance.
 - ❖ If these suggestions do not solve the problem, re-flash the host adapter and re-install the Windows NT driver.

Appendix A Standards and compliances

The equipment described in this manual generates and uses radio frequency energy. The Technical Specification sheet for a particular ATTO ExpressPCI host bus adapter list certifications for that model.



FCC standards: radio and television interference

WARNING This equipment has been tested and found to comply with the limits for a Class B digital device, pursuant to Part 15 of the FCC Rules. These limits are designed to provide reasonable protection against harmful interference in a residential installation.

This equipment generates, uses, and can radiate radio frequency energy and, if not installed and used in accordance with the instruction manual, may cause interference to radio communications. However, there is no guarantee that interference will not occur in a particular installation. If this equipment does cause interference to radio or television reception, which can be determined by turning the equipment off and on, the user is encouraged to try to correct the interference by one or more of the following measures:

- ❖ Reorient or relocate the receiving antenna
- ❖ Increase the separation between the equipment and receiver
- ❖ Connect the equipment into an outlet on a circuit different from that to which the receiver is connected
- ❖ Consult the dealer or an experienced radio/TV technician for help



Canadian standards

This Class B digital apparatus complies with Canadian ICES-003.

Cet appareil numérique de la classe B est conforme à la norme NMB-003 du Canada.



European standards

Declaration of Conformity

This following statement applies to the ATTO Express PCI host bus adapter.

This device has been tested in the basic operating configuration and found to be compliant with the following European Union standards:

Application of Council Directive: 89/336/EEC

Standard(s) to which conformity is declared: EN55024:1998

This Declaration will only be valid when this product is used in conjunction with other CE approved devices and when the entire system is tested to the applicable CE standards and found to be compliant.

Usage restrictions

The use of optical instruments with this product will increase eye hazard.

The multimode transceiver is a Class 1 laser product complying with IEC 825-1 and FDA-21 CFR 1040.11. To meet laser safety requirements, the transceiver shall be operated within the maximum ratings. The laser is non-OFC compliant as it is a Class 1 device.

The optical ports of the modules must be terminated with an optical connector or with a dust plug.

CAUTION Failure to adhere to the above restrictions could result in a modification that is considered an act of “manufacturing” and will require, under law, recertification of the modified product with the U.S. Food and Drug Administration (ref. 21 CFR 1040.10(i)).

Appendix B Fibre Channel accessories

The following Fibre Channel accessories are available through ATTO Technology and authorized resellers. Contact an ATTO Technology authorized sales representative to order.

Copper Cables

| | |
|--------------|---|
| CBL-HSDB-03X | HSSDC to DB9 Copper Fibre Channel Cable – 3m. |
| CBL-HSDB-10X | HSSDC to DB9 Copper Fibre Channel Cable – 10m. |
| CBL-HSHS-03X | HSSDC to HSSDC Copper Fibre Channel Cable – 3m. |
| CBL-HSHS-10X | HSSDC to HSSDC Copper Fibre Channel Cable – 10m. |
| CBL-FCCU-003 | DB9 Copper Fibre Channel Cable (Unequalized) – 3m. |
| CBL-FCCU-010 | DB9 Copper Fibre Channel Cable (Unequalized) – 10m. |
| CBL-FCCE-020 | DB9 Copper Fibre Channel Cable (Equalized) – 20m. |

Optical Cables

| | |
|--------------|--|
| CBL-FCFI-05x | 5 m. cable– Duplex 50 Micron Multi-mode FC/Optical |
| CBL-LCSC-003 | 3 m. 50/125 optical cable (LC to SC) |
| CBL-LCSC-010 | 10 m. 50/125 optical cable (LC to SC) |

MIA

| | |
|---------------|--|
| ADAP-MIAS-BLK | Media Interface Adapter (MIA) Short Wave |
|---------------|--|

A variety of Fibre Channel and SCSI products are also available from ATTO Technology. Please contact your ATTO sales representative for product descriptions and part number information.

Fibre Channel solutions

| | |
|-------------------------|--|
| FC Rack System | Modular Fibre Channel rack |
| ATTO FibreBridge™ | Fibre Channel-to-SCSI bridge |
| ATTO FibreCenter™ | Fibre Channel Hub |
| ATTO ExpressPCI FCSW | 1-Gigabit Fibre Channel Host Adapter |
| ATTO ExpressPCI FC 2600 | 1-Gigabit Fibre Channel Host Adapter |
| ATTO ExpressPCI FC 3300 | 2-Gigabit Fibre Channel Host Adapter |
| ATTO ExpressPCI FC 3305 | 2-Gigabit Fibre Channel Host Adapter |
| ATTO ExpressPCI FC 3321 | 2-Gigabit Fibre Channel Host Adapter, Dual Channel |
| ATTO ExpressPCI FC 3322 | 2-Gigabit Fibre Channel Host Adapter, Dual Channel |
| ATTO ExpressPCI FC 3342 | 2-Gigabit Fibre Channel Host Adapter, Quad Channel |

SCSI solutions

ATTO ExpressPCI Family of SCSI Host Adapters

Software

| | |
|----------------------------|---|
| ATTO Accelware | SAN (Storage Area Network) volume management software |
| ATTO ExpressRAID | Creates RAID groups across storage in networks |
| ATTO ExpressPro-Tools | Configuration and management software |
| ATTO ExpressStripe for OSX | MacOS X RAID and benchmark software |

Appendix C SCSI host adapter selection guide

ATTO Technology offers a number of SCSI and Fibre Channel solutions for storage. The following chart compares the features of ExpressPCI SCSI host adapters.

Supported platforms: Sun Solaris; Linux; Windows XP/2000/NT, 95/98, and Macintosh OS and OS X.

Complete RAID packages are also available and include an ExpressPCI SCSI host adapter, ExpressRAID software and appropriate cable(s). Add "-KIT" suffix to host adapter product code (i.e. EPCI-UL3D-KIT)

Specific features

| <i>Single Channel</i> | ExpressPCI Ultra 320 | ExpressPCI Ultra 3 | ExpressPCI Ultra Wide |
|-----------------------|----------------------|--------------------|-----------------------|
| Max. transfer rate | 320 MB/sec | 160 MB/sec. | 40 MB/sec. |
| LVD | √ | √ | |
| HVD | | | |
| 64-bit | √ | √ | |
| 32-bit | √ | √ | √ |
| 33/66 MHZ | √ | √ | |
| 133 MHZ | √ | | |
| Bus ID support | 30 | 30 | 15 |
| Part number | EPCI-UL4S | EPCI-UL3S | EPCI-PSC |

| <i>Dual Channel--- 2 independent channels</i> | ExpressPCI Ultra 320 | Express PCI Ultra 3 |
|---|----------------------|---------------------|
| Max. transfer rate | 640 MB/sec | 320 MB/sec. |
| LVD | √ | √ |
| 64-bit | √ | √ |
| 32-bit | √ | √ |
| 33/66 MHZ | √ | √ |
| 133 MHZ | √ | |
| Bus ID support | 30 | 30 |
| Part number | EPCI-UL4D | EPCI-UL3D |

Appendix D Contact ATTO Technology, Inc.

Customer service, sales information and technical support are available by phone Monday through Friday, Eastern Standard Time 8:00 a.m. to 8:00 p.m., or by e-mail and web site 24-hours a day.

ATTO Technology, Inc.
155 CrossPoint Parkway
Amherst, New York 14068
(716) 691-1999 • voice
(716) 691-9353 • fax
<http://www.attotech.com>

ATTO Technology can also be reached via e-mail at the following addresses:

Sales Support:
Technical Support:

sls@attotech.com
techsupp@attotech.com