



**CONTENTS**

**SAFETY INFORMATION** .....2  
 FOR YOUR SAFETY ..... 2

**SYSTEM OPERATION** .....2  
 THERMOSTATS ..... 2  
 INTERMITTENT IGNITION DEVICE ..... 2  
 INPUT ..... 3  
 OPERATING INSTRUCTIONS ..... 3

**MAINTENANCE** .....4  
 GENERAL ..... 4  
 HEATING SYSTEM INSPECTION ..... 4  
 LUBRICATION ..... 4  
 AIR FILTERS ..... 4  
 CONDENSER COIL ..... 4  
 BLOWER ASSEMBLY ..... 4  
 BEFORE CALLING A SERVICE PERSON: ..... 4

**REPLACEMENT PARTS** .....5

# **USER'S, MAINTENANCE and SERVICE INFORMATION MANUAL**

## **SINGLE PACKAGE AIR CONDITIONER GAS/ELECTRIC**

The manufacturer recommends that the "User" read all sections of this manual and keep the manual for future reference.

### **▲WARNING**

#### **FIRE OR EXPLOSION HAZARD**

Failure to follow safety warnings exactly could result in serious injury, death, or property damage.

- Do not store or use gasoline or other flammable vapors and liquids in the vicinity of this or any other appliance.

- **WHAT TO DO IF YOU SMELL GAS:**

- Do not try to light any appliance.
- Do not touch any electrical switch; do not use any phone in your building.
- Leave the building immediately.
- Immediately call your gas supplier from a neighbor's phone. Follow the gas supplier's instructions.
- If you cannot reach your gas supplier, call the fire department.

- Installation and service must be performed by a qualified installer, service agency or the gas supplier.



## SAFETY INFORMATION

### FOR YOUR SAFETY

- Make sure that the furnace area is clear and free of combustible materials, gasoline and other flammable vapors and liquids.
- Be sure the furnace is free and clear of insulating material. Examine the furnace area after installation of the furnace or the installation of additional insulation. Some types of insulation are combustible.
- For proper operation of this furnace, air for combustion and ventilation is required. Make sure that these openings are not obstructed.
- For lighting or shutting down this furnace, refer to the lighting instructions provided adjacent to the burners and also located in this manual.
- A blocked vent roll-out switch is provided in the burner compartment. This switch is a manual reset. If the furnace fails to operate, contact a qualified service technician.
- Should the gas supply fail to shut off or if overheating occurs, shut off the gas valve to the furnace before shutting off the electrical supply. Then call a qualified service technician.
- Do not use this furnace if any part has been under water. A flood-damaged furnace is extremely dangerous. Attempts to use the furnace can result in fire or explosion. A qualified service technician should be contacted to inspect the furnace and to replace all gas controls, control system parts, electrical parts that have been wet or the furnace if deemed necessary.
- Determine the integrity of the installation regarding the flue gas vent, the return and supply air duct. Confirm the equipment is well supported and there are no signs of deterioration. The manufacturer recommends that main burner, ignition device and controls are inspected by a qualified service technician before each heating season.

## SYSTEM OPERATION

### THERMOSTATS

Set your thermostat for either heating or cooling then set it for the desired temperature. **DO NOT MOVE THE THERMOSTAT RAPIDLY ON AND OFF, OR BACK AND FORTH FROM HEAT TO COOL. THIS COULD DAMAGE YOUR EQUIPMENT.**

Always allow at least 5 minutes between changes. Find the temperature that is most comfortable to you, and then **LEAVE YOUR THERMOSTAT ALONE.** (Exception is for night or vacation "set back" to conserve energy).

Manually moving the thermostat up or down will not speed up temperature changes in your rooms. This only causes the thermostat switch to function at your command rather than responding to room temperature.

Heat generated by devices other than the furnace may interfere with thermostat performance. Therefore, lamps, radios, television sets, etc. should not be placed near the thermostat.

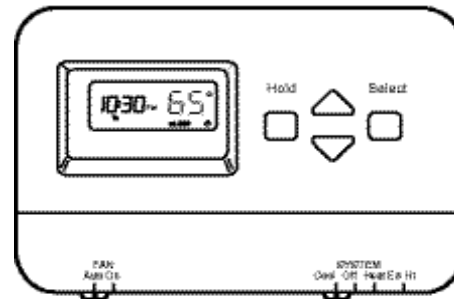

**FIGURE 1 - TYPICAL THERMOSTAT  
INTERMITTENT IGNITION DEVICE**

Your unit is equipped with a cycling spark ignition device. It has a Relight control designed to automatically light the burners each time the thermostat controller "calls" for heat.

### **CAUTION**

This furnace is equipped with an intermittent spark and automatic re-ignition system. **Do Not** attempt to manually relight the pilot. Personal injury could result.

When the controller calls for heat, gas is supplied to the Integral Crossover Burners and at the same time, sparking occurs to light the main burner gas. A flame sensor closes a circuit to the ignitor control which proves that all of the burners have ignited properly.

On initial start-up, air may be in the gas lines. Several tries for ignition may be required before the gas will carry over and the heat sections remains lit. The ignition model has 3 trials for ignition. If the ignition module locks out, it may be necessary to remove re-establish the call for heat W1 or W2 to continue the purging process.

When the controller is satisfied, the electrical circuit to the gas valve is opened, closing off the flow of gas to the main burner.

If the burners should fail to light, contact your heating contractor or gas company for service to insure that proper operating conditions are restored.

In the event that gas to the main burner has been shut-off, **DO NOT** attempt to place the furnace into operation. Call the appropriate service agency.

## INPUT

The correct heat capacity of the furnace is regulated by the main burner orifices and the gas pressure. The proper orifices for natural gas are furnished but the gas pressure regulator must be adjusted by the installer or gas company service person.

## OPERATING INSTRUCTIONS

### TO SHUT DOWN THE FURNACE:

1. Close the main gas shutoff valve(s).
2. Turn off the electric power supply.

### TO LIGHT THE FURNACE:

1. Do not attempt to light manually.
2. Open the main gas shutoff valve(s).
3. Turn on the electric power supply.
4. Initiate a call for heat.
5. If the return air temperature is below the set point of the controller, the ventor fans will operate. After an adequate purge time, the intermittent ignition device will light the burners. The burners will extinguish and relight automatically upon the demand of the controller.

## VENT SAFETY SYSTEM

Each gas furnace module is equipped with an automatic reset high temperature limit and rollout switch. In the unlikely event of a sustained main burner flame rollout, the switch will shut off the flow of gas by closing the main gas valve. The ignition module will also be disabled, preventing the flow of gas to the valve. The rollout switch for each module is located inside the gas heat section access door on the heat shield of each module. Flame rollout can be caused by blockage of the power vent system or improper gas pressure adjustment. If this occurs the furnace will not operate properly, gas supply to the furnace should be shut off and no attempt should be made to place the furnace in operation. The system should be inspected by a qualified service person. Refer to Figure 3 for a typical installation of vent hoods.

The ignition modules are designed such that if the furnace fails to ignite after 3 trials for ignition after a call for heat the flow of gas will be shut off and the ignition module will lock out for one hour. Then the modules will retry ignition and repeat cycle until ignition occurs, or call for heat is satisfied or power to unit is removed. If the furnace does not light after several tries, a service man should be called to determine the cause of the problem.

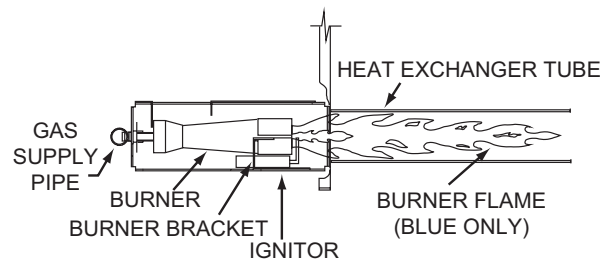

**FIGURE 2 - TYPICAL FLAME APPEARANCE**

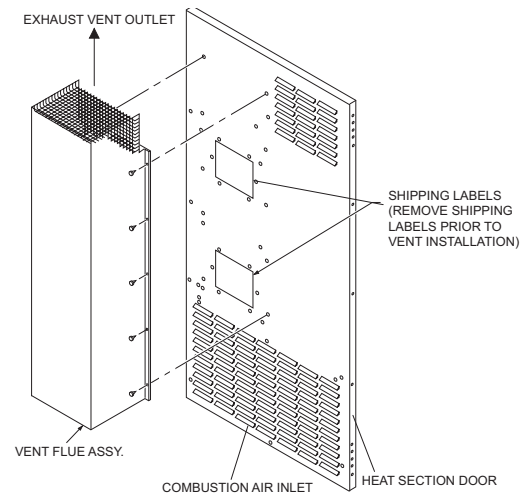

**FIGURE 3 - FLUE VENT ASSEMBLY**

This furnace is equipped with a blocked vented shut-off system (air proving switch). The purpose of the switch is to prove that there is combustion air being drawn through the heat section. The ignition control will not operate if this switch is not made in the pre-purge time of the vent assembly. In the event that the furnace fails to operate due to the pressure switch, a qualified service agency should be contacted.

Determine that external vent is in place (field installed) and clear and free of obstructions.

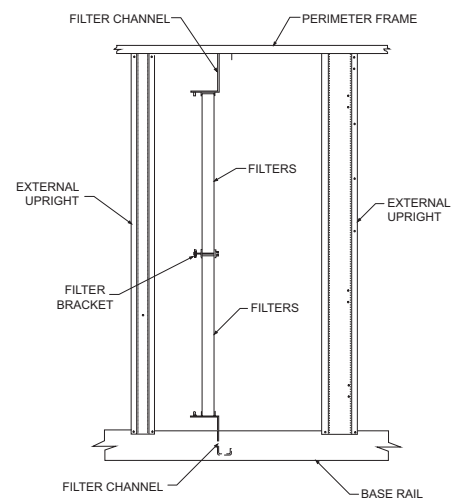

**FIGURE 4 - FILTER ACCESS**

## MAINTENANCE

### GENERAL

Snow or debris should not be allowed to accumulate in or around the unit. Do not permit overhanging structures or shrubs to obstruct condenser air discharge, combustion air inlets or vent air outlets on your unit. Adequate air is important to the safe and proper operation of the unit.



### WARNING

Prior to any of the following maintenance procedures, shut off all power to the unit.

### HEATING SYSTEM INSPECTION

It is the owner's responsibility to insure that an annual inspection of the entire heating portion of the unit is made by a qualified service agency. This should include inspection of the burners, tubes and flue for any corrosion or soot accumulation which may require cleaning and also checking of burners and controls for proper operation.

In addition, at least once during the heating season, the owner shall make a visual inspection of the flue or vent air outlets for evidence of black soot or blockage by leaves or other debris. If any soot is found it is recommended a qualified service agency be called immediately. Also clear any blockage found around either the vent air hoods or combustion air inlets.

Check for obvious signs of deterioration of the furnace. Check that the return and supply ducts attached to the unit are sound and air tight without sagging cracks or gaps. Check that the unit's physical support, or roof curb, is sound and not in need of repair. Make sure there are no gaps between the roof curb and the unit where rain could leak.

Start the furnace. The ventor motors should start and after a short delay the main burners should ignite. If they do not, contact a qualified service person for assistance. Check the appearance of each main burner flame. The flame should have a blue appearance. No yellow flame should be observed. A yellow flame indicates a problem with the combustion system or that cleaning is required.

### LUBRICATION

Outdoor fan and ventor motors are permanently lubricated. Lubrication is not recommended.

All other fans and motors should be lubricated per schedule in MAINTENANCE SECTION in the UNIT INSTALLATION INSTRUCTION.

### AIR FILTERS

**NOTE:** For hi-efficiency rigid or bag filters, consult manufacturers manual.

Filters must always be used. They should be inspected once a month and thoroughly cleaned or replaced if it appears they are beginning to accumulate excessive dirt. Filter sizes and quantities are shown in the following table.

To install the filters, open the filter access door.

Slide the dirty filters out and slide the clean filters all the way into the filter racks provided (see Fig. 4). They must butt each other when sliding into position. Close the filter access door.

**NOTE:** Filters must be installed with "Air Flow" arrows pointing toward the evaporator coil. They must also be re-installed in their original position without any gaps between filters.

### CONDENSER COIL

An annual check and cleaning, if necessary, of the condenser coil should be done. Clean any debris and dirt from the outside coil face with a brush being careful not to damage the fins. If extremely dirty, a hose can be used to wash the coil from the inside out while brushing a soapy solution on the outside.

### BLOWER ASSEMBLY

Even with good filters properly in place, blower wheels and motors will become dust laden after long months of operation. The entire blower assembly should be inspected annually. If the motor and/or the blower wheel are heavily coated with dust, they can be brushed and cleaned with a vacuum cleaner.

### BEFORE CALLING A SERVICE PERSON:

- A. Check controller setting and insure it is calling for heating or cooling.
- B. Check fuses or circuit breakers.
- C. Check filters for excessive dust accumulation.

**TABLE 1: FILTERS**

| FILTER                      | QUANTITY PER UNIT AND SIZE    |                               |                               |
|-----------------------------|-------------------------------|-------------------------------|-------------------------------|
|                             | 25 TON                        | 30 TON                        | 40 TON                        |
| 2 Hi Eff. TA                | 4 ea. 16 x 25 / 6 ea. 20 x 25 | 4 ea. 16 x 25 / 6 ea. 20 x 25 | 4 ea. 16 x 25 / 6 ea. 20 x 25 |
| 2 Pleated, 65%              | 4 ea. 16 x 25 / 6 ea. 20 x 25 | 4 ea. 16 x 25 / 6 ea. 20 x 25 | 4 ea. 16 x 25 / 6 ea. 20 x 25 |
| 65% Rigid w/2 TA Prefilters | 4 ea. 16 x 25 / 6 ea. 20 x 25 | 4 ea. 16 x 25 / 6 ea. 20 x 25 | 4 ea. 16 x 25 / 6 ea. 20 x 25 |
| 95% Rigid w/2 TA Prefilters | 4 ea. 16 x 25 / 6 ea. 20 x 25 | 4 ea. 16 x 25 / 6 ea. 20 x 25 | 4 ea. 16 x 25 / 6 ea. 20 x 25 |

OWNER please have your installer fill in the following information immediately after unit has been installed and is properly operating.

Installed by \_\_\_\_\_

Installer's Address \_\_\_\_\_

Installation Date \_\_\_\_\_

Owner's Name \_\_\_\_\_

Owner's Address \_\_\_\_\_

Equipment installed at (address) \_\_\_\_\_

Model Number \_\_\_\_\_ Serial Number \_\_\_\_\_

Distributor from whom the equipment was purchased \_\_\_\_\_

*The owner should keep this information in a place where it can be found if needed for warranty purposes.*

## REPLACEMENT PARTS

Contact your local York® parts distribution center for authorized replacement parts.





