

Residential Powerful Compact[®] Energy Saver Electric Water Heater



Photo is of
M1-2U6SS

The Residential Energy Saver Electric Model Features:

- **Compact Design**—Can be mounted almost anywhere - under a sink, inside cabinets or hung on a wall and is perfect for wash station applications (factories, stores and offices).
- **Fully Automatic Control**—Fast acting surface-mount thermostat for automatic temperature control. Factory installed (sensitive) manual reset energy cut-off for safety to prevent overheating.
- **Direct Heat Transfer with Immersed Element**—Transfers heat directly and efficiently to the water. Screw-in style.
- **Vitraglas[®] Lining**—Bradford White water heater tanks are protected from the corrosive effects of hot water by an exclusive ceramic porcelain-like coating. The Bradford White high silica Vitraglas[®] lining provides a tough interior surface for our hot water tanks.
- **Non-CFC Insulation**—Precast surrounds tank.
- **Water Connections**—3/4" NPT factory installed true dielectric fittings extend water heater life and eases installation.
- **Protective Magnesium Anode Rod**—Provides added protection against corrosion for long, trouble free service.
- **Steel Tank**—Heavy gauge steel automatically formed, rolled and welded.
- **Steel Jacket**—With special coating that inhibits rust and corrosion.
- **T&P Relief Valve Opening**—Special tapping on top of tank.

Optional Features:

- **Wall Mounting Bracket.**
- **North Carolina Compliant.**
- **Aluminum Anode Rod.**

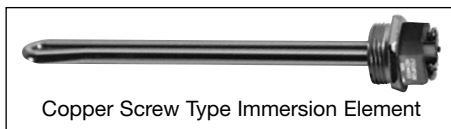

Copper Screw Type Immersion Element



6 or 10-Year Limited Tank Warranties / 6-Year Limited Warranty on Component Parts.

For more information on warranty, please visit www.bradfordwhite.com

For products installed in USA, Canada and Puerto Rico. Some states do not allow limitations on warranties. See complete copy of the warranty included with the heater.

MANUFACTURED UNDER ONE OR MORE OF THE FOLLOWING U.S. PATENTS: 5,954,492; 5,761,379; 5,943,984; 5,081,696; 5,988,117; 6,142,216; 5,199,385; 5,574,822; 5,372,185; 5,485,879; 5,277,171; (B1)5,341,770; 5,660,165; 5,596,952; 5,682,666; 4,904,428; 5,023,031; 5,000,893; 4,669,448; 4,829,983; 4,808,356; 5,115,767; 5,092,519; 5,052,346; 4,416,222; 4,628,184; 4,861,968; 4,672,919; Re. 34,534; 7,270,087 B2. OTHER U.S. AND FOREIGN PATENT APPLICATIONS PENDING. CURRENT CANADIAN PATENTS: 1,272,914; 1,280,043; 1,289,832; 2,045,862; 2,112,515; 2,108,186; 2,107,012; 2,092,105; 2,409,271. Powerful Compact[®] and Vitraglas[®] are a registered trademarks of Bradford White[®] Corporation. ©2008, Bradford White Corporation. All rights reserved. Printed in U.S.A.

Residential Electric Water Heater

Powerful Compact® Energy Saver Model

Meet or exceed ASHRAE 90.1b (current standard)

Model Number	Capacity		Recovery 90°F Rise		A Floor to Heater Top	B Jacket Dia.	C Floor to Water Conn.	Approx. Shipping Weight
	U.S. Gal.	Imp. Gal.	U.S. GPH	Imp. GPH	in.	in.	in.	lbs.
M1-2U6SS	2	1.7	7	6	12 ¹ / ₄	9 ⁷ / ₈	13 ⁵ / ₁₆	12

Model Number	Capacity		Recovery 50°C Rise		A Floor to Heater Top	B Jacket Dia.	C Floor to Water Conn.	Approx. Shipping Weight
	Liters		Liters/* Hour		mm.	mm.	mm.	kg.
M1-2U6SS	7		26		311	251	338	5

Includes a 4ft. cord with 3 prong grounded plug (20 amp circuit required).

For 10 year models, change suffix "6" to "10".

Single element only.

*Based on 1500W operation.

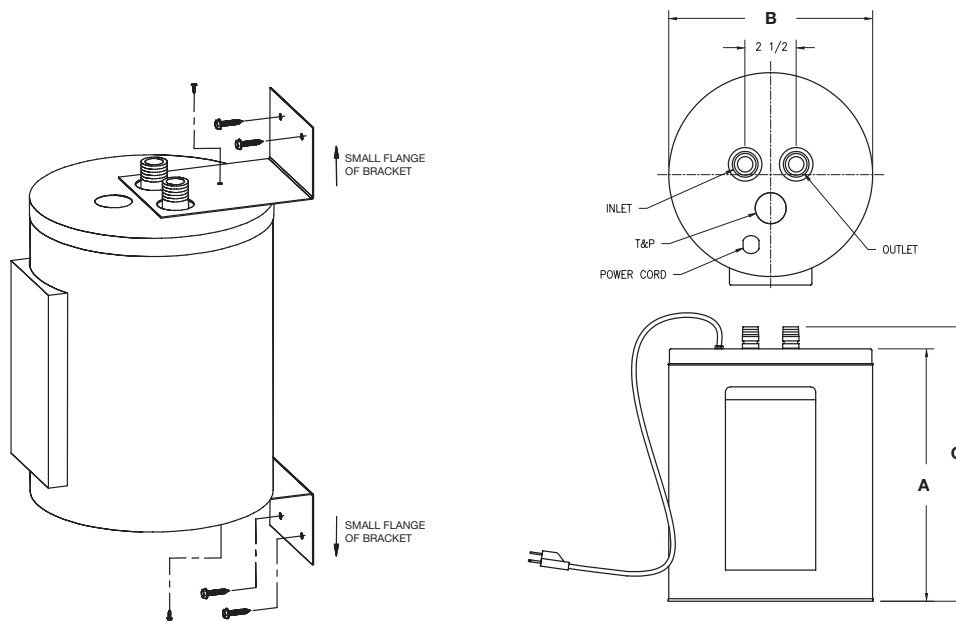

Optional Wall Mounting Bracket (2 brackets)
Part Number 265-45018-00

General

All models UL and C-UL listed. All water connections, 3/4" (19mm) NPT. T&P connection, 3/4" (19mm) NPT female.

All models certified at 300 psi test pressure (2068 kPa) and 150 psi working pressure (1034 kPa).

Dimensions and specifications subject to change without notice in accordance with our policy of continuous product improvement.



For U.S. and Canada field service, contact your professional installer or local Bradford White sales representative.

Sales 800-523-2931 • Fax 215-641-1670 / Technical Support 800-334-3393 • Fax 269-795-1089 • Warranty 800-531-2111 • Fax 269-795-1089

International: Telephone 215-641-9400 • Telefax 215-641-9750 / www.bradfordwhite.com



BRADFORD WHITE-CANADA INC. Sales / Technical Support 866-690-0961 / 905-238-0100 • Fax 905-238-0105 / www.bradfordwhite.com

Built to be the Best™

©2008, Bradford White Corporation. All rights reserved.