

Pioneer *sound.vision.soul*

Stereo DVD Cassette Deck Receiver

XV-GX3

Speaker System

S-GX3V



Operating Instructions

RW
COMPATIBLE

Thank you for buying this Pioneer product. Please read through these operating instructions so you will know how to operate your model properly. After you have finished reading the instructions, put them away in a safe place for future reference.

IMPORTANT



The lightning flash with arrowhead symbol, within an equilateral triangle, is intended to alert the user to the presence of uninsulated "dangerous voltage" within the product's enclosure that may be of sufficient magnitude to constitute a risk of electric shock to persons.

CAUTION

**RISK OF ELECTRIC SHOCK
DO NOT OPEN**

CAUTION:

TO PREVENT THE RISK OF ELECTRIC SHOCK, DO NOT REMOVE COVER (OR BACK). NO USER-SERVICEABLE PARTS INSIDE. REFER SERVICING TO QUALIFIED SERVICE PERSONNEL.



The exclamation point within an equilateral triangle is intended to alert the user to the presence of important operating and maintenance (servicing) instructions in the literature accompanying the appliance.

D3-4-2-1-1_En-A

CAUTION

This product is a class 1 laser product, but this product contains a laser diode higher than Class 1. To ensure continued safety, do not remove any covers or attempt to gain access to the inside of the product. Refer all servicing to qualified personnel. The following caution label appears on your unit.

Location: rear of the unit

Singapore, Malaysia, Taiwan, Indonesia, Philippines models

CAUTION : CLASS 3B VISIBLE AND INVISIBLE LASER RADIATION WHEN OPEN, AVOID EXPOSURE TO THE BEAM.

注意：打開時會有CLASS 3B可見和不可見雷射輻射，請勿受雷射束輻射。

VRW2159

All other models

CAUTION : VISIBLE AND INVISIBLE LASER RADIATION WHEN OPEN, AVOID EXPOSURE TO BEAM.

VORSICHT : SICHTBARE UND UNSICHTBARE LASERSTRAHLUNG, WENN ABDECKUNG GEÖFFNET NICHT DEM STRAHL AUSSETZEN!

ADVARSEL : SYNLIG OG USYNLIG LASERSTRÅLING VED ÅBNING
UNDGÅ UDSÆTTELSE FOR STRÅLING.

VARNING : SYNLIG OCH OSYNLIG LASERSTRÅLNING NÄR DENNA DEL ÄR ÖPPNAD BETRÄKTA EJ STRÅLEN.

VARO! : AVATTAESSA ALTISTUT NÄKYVÄ JA NÄKYMÄTTÖMÄLLE LASERSATEIL YLLE. ÄLÄ KATSO SÄTEESSEN.

VRW1689

Location: rear of the unit

**CLASS 1
LASER PRODUCT**

D3-4-2-1-8_A_En

WARNING

This equipment is not waterproof. To prevent a fire or shock hazard, do not place any container filled with liquid near this equipment (such as a vase or flower pot) or expose it to dripping, splashing, rain or moisture.

D3-4-2-1-3_A_En

WARNING

Before plugging in for the first time, read the following section carefully.

The voltage of the available power supply differs according to country or region. Be sure that the power supply voltage of the area where this unit will be used meets the required voltage (e.g., 230V or 120V) written on the rear panel.

D3-4-2-1-4_A_En

WARNING

To prevent a fire hazard, do not place any naked flame sources (such as a lighted candle) on the equipment.

D3-4-2-1-7a_A_En

Recording equipment and copyright: Recording equipment should be used only for lawful copying and you are advised to check carefully what is lawful copying in the country in which you are making a copy. Copying of copyright material such as films or music is unlawful unless permitted by a legal exception or consented to by the rightowners.

K018_En

VENTILATION CAUTION

When installing this unit, make sure to leave space around the unit for ventilation to improve heat radiation (at least 10 cm at top, 10 cm at rear, and 10 cm at each side).

WARNING

Slots and openings in the cabinet are provided for ventilation to ensure reliable operation of the product, and to protect it from overheating. To prevent fire hazard, the openings should never be blocked or covered with items (such as newspapers, table-cloths, curtains) or by operating the equipment on thick carpet or a bed.

D3-4-2-1-7b_A_En

CAUTION

The STANDBY/ON switch on this unit will not completely shut off all power from the AC outlet. Since the power cord serves as the main disconnect device for the unit, you will need to unplug it from the AC outlet to shut down all power. Therefore, make sure the unit has been installed so that the power cord can be easily unplugged from the AC outlet in case of an accident. To avoid fire hazard, the power cord should also be unplugged from the AC outlet when left unused for a long period of time (for example, when on vacation).

D3-4-2-2-2a_A_En

CAUTION

These speaker terminals carry **HAZARDOUS LIVE voltage**. To prevent the risk of electric shock when connecting or disconnecting the speaker cables, disconnect the power cord before touching any uninsulated parts.

D3-4-2-2-3_A_En

Operating Environment

Operating environment temperature and humidity: +5 °C – +35 °C (+41 °F – +95 °F); less than 65 %RH (cooling vents not blocked)

Do not install this unit in a poorly ventilated area, or in locations exposed to high humidity or direct sunlight (or strong artificial light)

D3-4-2-1-7c_A_En

POWER-CORD CAUTION

Handle the power cord by the plug. Do not pull out the plug by tugging the cord and never touch the power cord when your hands are wet as this could cause a short circuit or electric shock. Do not place the unit, a piece of furniture, etc., on the power cord, or pinch the cord. Never make a knot in the cord or tie it with other cords. The power cords should be routed such that they are not likely to be stepped on. A damaged power cord can cause a fire or give you an electrical shock. Check the power cord once in a while. When you find it damaged, ask your nearest PIONEER authorized service center or your dealer for a replacement.

S002_En

This product incorporates copyright protection technology that is protected by method claims of certain U.S. patents and other intellectual property rights owned by Macrovision Corporation and other rights owners. Use of this copyright protection technology must be authorized by Macrovision Corporation, and is intended for home and other limited uses only unless otherwise authorized by Macrovision Corporation. Reverse engineering or disassembly is prohibited.

This product is for general household purposes. Any failure due to use for other than household purposes (such as long-term use for business purposes in a restaurant or use in a car or ship) and which requires repair will be charged for even during the warranty period.

K041_En

Voltage selector

You can find the voltage selector switch on the rear panel of multi-voltage models.

The factory setting for the voltage selector is 220V–230V. Please set it to the correct voltage for your country or region.

- For Taiwan, please set to 110V–120V before using.

Before changing the voltage, disconnect the AC power cord. Use a medium size screwdriver to change the voltage selector switch.

Singapore, Malaysia, Taiwan, Indonesia, Philippines models

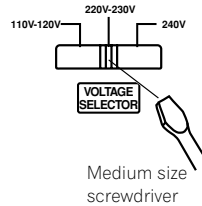

All other models

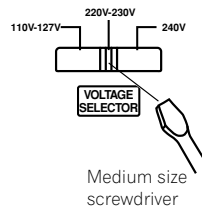

D3-4-2-1-5_En

For Taiwan exclusively

Taiwanese two pin flat-bladed plug

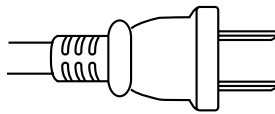

DRM (digital rights management) copy protection is a technology designed to prevent unauthorized copying by restricting playback, etc. of material on devices other than the PC (or other WMA recording equipment) used to record it. For detailed information, please see the instruction manuals or help files that came with your PC and/or software.

This product includes FontAvenue® fonts licenced by NEC corporation. FontAvenue is a registered trademark of NEC Corporation.

Contents

01 Before you start

Checking what's in the box	5
Loading the batteries	5
Attaching the non-skid pads	5
Removing the front speaker grilles	5

02 Connecting up

Connecting the speaker terminals	6
Optional surround speaker connections	6
Connecting the radio antennas	7
Connecting external antennas	7
Connecting to your TV	8
Connecting using component video	8
Connecting auxiliary components	9
Connecting the power	9

03 Controls and displays

Front panel	10
Display	11
Remote control	12

04 Getting started

Using the on-screen displays	14
Playing discs	14
Basic playback controls	15
Resume and Last Memory	15
DVD-Video disc menus	15
Video CD/Super VCD PBC menus	16
Playing cassette tapes	16
Basic playback controls	16
Listening to the radio	17
Automatically saving station presets	17
Listening to station presets	17
Listening to other sources	17
Setting the sleep timer	17

05 Disc playback features

Scanning discs	18
Playing in slow motion	18
Frame advance/frame reverse	18
Playing a JPEG slideshow	18
Browsing DVD or Video CD/Super VCD discs with the Disc Navigator	19
Browsing WMA, MP3, DivX video and JPEG files with the Disc Navigator	19
Looping a section of a disc	20
Using repeat play	20
Using random play	21
Creating a program list	21
Using the OSD	21
Other functions available from the program menu	22
Using the front panel display	22
Searching a disc	22
Switching subtitles	23
Switching language / audio channels	23
Zooming the screen	23
Switching camera angles	23
Displaying disc information	23

06 Making tape recordings

Manual recording to cassette	24
------------------------------------	----

07 Manual tuner features

Selecting stations manually	25
Manually saving station presets	25
Improving FM stereo sound	25

08 Singing karaoke

Singing karaoke	26
Changing the vocal mix	26
Changing the backing track	26

09 Adjusting the sound

Using the Sound menu	27
Using the Sound Field Control	27
Boosting the bass level	27
Muting the sound	27

10 Audio Settings and Video Adjust menu

Audio Settings menu	28
Virtual Surround	28
Audio DRC	28
Video Adjust menu	28

11 Initial Settings menu

Using the Initial Settings menu	29
Video Output settings	29
Language settings	29
Display settings	30
Options settings	30
Parental Lock	30
About DivX® VOD content	31

12 Additional information

Using the System Setup menu	33
System Setup menu options	33
System Setup menu options in standby	33
Disc / content format playback compatibility	34
Disc compatibility table	35
DVD Video regions	35
About DivX	35
About WMA	36
Taking care of discs	36
Using cassette tapes	37
Tapes you should avoid	37
Protecting your recordings	37
Installation and maintenance	37
Hints on installation	37
Cleaning the pickup lens	38
Problems with condensation	38
Moving the system unit	38
Resetting the system	38
Screen sizes and disc formats	38
Using the language code list	38
Language code list	39
Country/Area code list	39
Troubleshooting	40
General	40
DVD/CD/Video CD player	41
WMA/MP3/JPEG discs	41
Tuner	42
Tape deck	42
Error Messages	42
Specifications	43

Chapter 1

Before you start

Checking what's in the box

Please check that you've received the following supplied accessories:

- Remote control
- Dry cell batteries (AA/R6) x2
- Video cord
- AM loop antenna
- FM antenna
- Power cord:
 - Singapore, Malaysia, Taiwan, Indonesia and Philippines models x2
 - All other models x1
- Non-skid pads (in speaker box) x8
- These operating instructions

Loading the batteries

Use AA/R6 batteries with the supplied remote control. Make sure to follow the indications (⊕, ⊖) inside the compartment.

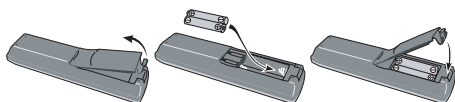

Important

Incorrect use of batteries may result in such hazards as leakage and bursting. Observe the following precautions:

- Never use new and old batteries together.
- Insert the plus and minus sides of the batteries properly according to the marks in the battery case.

- Batteries with the same shape may have different voltages. Do not use different batteries together.
- When disposing of used batteries, please comply with governmental regulations or environmental public instruction's rules that apply in your country or area.

Attaching the non-skid pads

Use the self-adhesive non-skid pads to provide a stable base for the speakers. Attach four to each speaker as shown below.

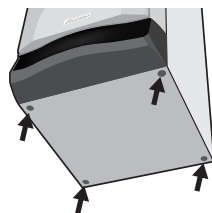

Removing the front speaker grilles

If necessary, remove the front speaker grilles as described below.

- 1 Gently ease the grille loose by gripping the bottom and pulling towards you.**
- 2 Pull the top free in the same way.**

When reattaching, start from the top then push the bottom in until secure.

- It is not recommended (due to dirt and dust) to leave the speaker grilles removed.
- If the speaker grille is not properly attached to the front of the speaker, it is possible it may fall off and cause injury. Therefore, we don't recommend placing the speaker in high locations where this is likely to happen.

Chapter 2

Connecting up



Important

- Before making or changing any connections, switch off the power and unplug the power cord from the AC outlet.
- When making cable connections, make sure not to bend the cables over the top of this unit. This may cause a humming noise from the speakers.

Connecting the speaker terminals

Place the front left and right speakers at equal distances from the TV¹, then connect the wires from the speakers to the terminals on the main unit rear panel as shown below. See *Optional surround speaker connections* on page 6 to connect surround speakers.



Caution

- Do not connect this speaker to any amplifier other than the one supplied with this system. Connection to any other amplifier may result in a malfunction or fire.
- Make sure that the bare speaker wires cannot touch each other, or come into contact with other metal parts once the unit is switched on.
- Do not attach these speakers to the wall or ceiling. They may fall off and cause injury.

- 1 Twist and pull off the protective shields on each wire.



- 2 Connect to the **FRONT** speaker terminals on the rear of the unit.

Make sure to insert the red wire into the red (+) tab and the black wire into the black (-) tab.

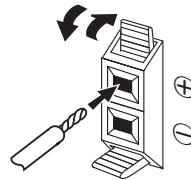

Optional surround speaker connections

Using RCA speaker cables, you can connect surround speakers to the left and right **SURROUND** speaker jacks on the rear panel for multichannel sound from this system.

For the best surround effect, place the surround speakers slightly above ear level and at the same distance from the listening position as the front speakers.



Important

- Use speakers with a nominal impedance of at least 16Ω.

Note

¹ The speakers supplied with this system are magnetically shielded. However, placing them extremely close to a television may result in color distortion on the screen. If this happens, move the speakers a little further away and switch off the television for 15–30 minutes.

- Make sure you connect both surround speakers or you won't be able to hear anything from the surround jacks.

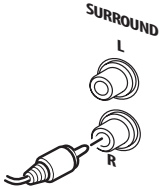

Connecting the radio antennas

Connecting the supplied antennas will allow you to listen to both AM and FM radio broadcasts. If you find that reception quality is poor, an outdoor antenna should give you better sound quality—see *Connecting external antennas* below for more on how to do this.

1 Pull off the protective shields of both AM antenna wires.

2 Push open the tabs, then insert one wire fully into each terminal, then release the tabs to secure the AM antenna wires.

3 Fix the AM loop antenna to the stand.

To fix the stand to the antenna, bend in the direction indicated by the arrow (*fig. a*) then clip the loop onto the stand (*fig. b*).

- If you plan to mount the AM antenna to a wall or other surface, secure the stand with screws (*fig. c*) before clipping the loop to the stand. Make sure the reception is clear.

4 Place the AM antenna on a flat surface and point in the direction giving the best reception.

Don't let it come into contact with metal objects and avoid placing near computers, television sets or other electrical appliances.¹

5 Connect the FM wire antenna to the FM UNLBAL 75Ω antenna terminal.

For best results, extend the FM antenna fully and fix to a wall or door frame. Don't drape loosely or leave coiled up.

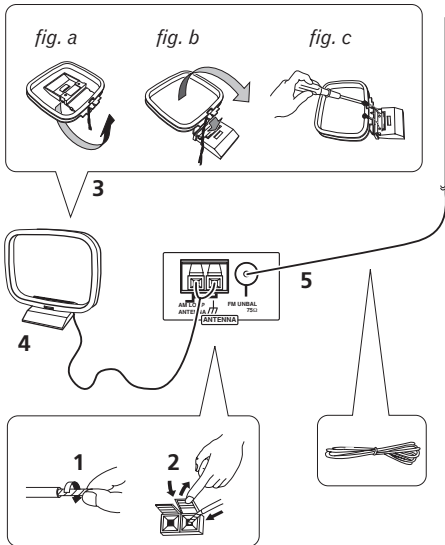

Connecting external antennas

External AM antenna

Use 5–6 meters of vinyl-insulated wire and set up either indoors or outdoors. Leave the AM loop antenna connected.

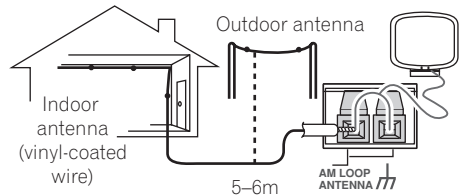

Note

¹ The signal ground (⚡) is designed to reduce noise that occurs when an antenna is connected. It is not an electrical safety ground.

External FM antenna

Use a PAL connector to hook up an external FM antenna.

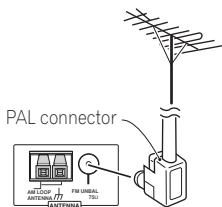

Connecting to your TV

This system offers three types of video connections. If your TV has component video inputs, see *Connecting using component video* below.

- 1 Use the supplied yellow video cable to connect the **VIDEO OUT** jack to a video input on your TV.



For a better image, you can also use a commercially available S-Video cable to connect the **S-VIDEO OUT** jack to an S-Video input on your TV.

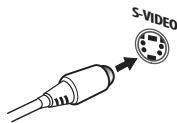

- 2 **Optionally:** Use a stereo audio cable to connect the audio outs of your TV (or VCR) to the **LINE IN** jacks on the rear of this unit.

This will enable you to hear the TV (or VCR) sound through this system. See *Connecting auxiliary components* below for more on this.

Connecting using component video

If your TV has component video inputs, you can use these instead of the standard or S-Video output to connect this system to your TV.¹ This should give you the best quality picture from the three types of video output available.

- Use a component video cable to connect the **COMPONENT VIDEO OUT** to a set of component inputs on your TV.

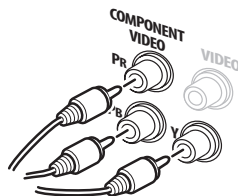

About progressive scan video

Compared to interlace video, progressive scan video effectively doubles the scanning rate of the picture, resulting in a very stable, flicker-free image. Progressive scan video is available only from the component video output.

Important

- If you connect a TV that is not compatible with a progressive scan signal and switch the system to progressive, you will not be able to see any picture at all. In this case, press **STANDBY/ON** to put the system in standby, select the interlace setting in the *System Setup menu options in standby* on page 33, then press **ENTER**.

Note

¹ The component video output is switchable between interlaced and progressive formats. See *Video Output settings* on page 29.

Compatibility of this player with progressive-scan and high-definition TVs.

This player is compatible with progressive video Macro Vision System Copy Guard.¹

This system is compatible with the following Pioneer displays and monitors: PDP-505HDG, PDP-435HDG, PDP-5040HD, PDP4340HD, PDP-502MX, PDP-503HDG, PDP-504HDG, PDP-433HDG, PDP-434HDG, SD-532HD5, SD533HD5.

Connecting auxiliary components

This system has both stereo analog inputs and outputs. Use these to connect external components, such as a VCR, MD, CD-R or DAT recorder.

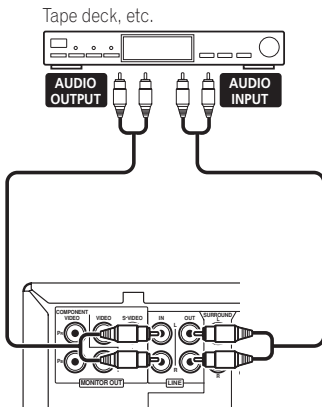

XV-GX3

- **Connect the LINE IN jacks on the rear panel to an auxiliary playback component.**

These include components such as a VCR, DAT, or your TV. Connect using RCA pin-plug stereo cables.

- **Connect the LINE OUT jacks on the rear panel to a recording component.**

These include components such as a cassette deck, VCR, MD recorder, or another recorder with analog inputs. Connect using RCA pin-plug stereo cables.

Connecting the power

After making sure that everything is connected properly, plug in the power cord to the AC inlet, and the other end to a mains power outlet.

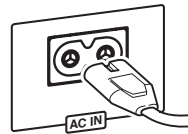

Congratulations! You're done setting up.

Note

¹ Consumers should note that not all high-definition television sets are fully compatible with this product and may cause artifacts to be displayed in the picture. In case of 525 progressive scan picture problems, it is recommended that the user switch the connection to the 'standard definition' output (Interlace). If there are questions regarding our TV set compatibility with this model, please contact our customer service center.

Chapter 3

Controls and displays

Front panel

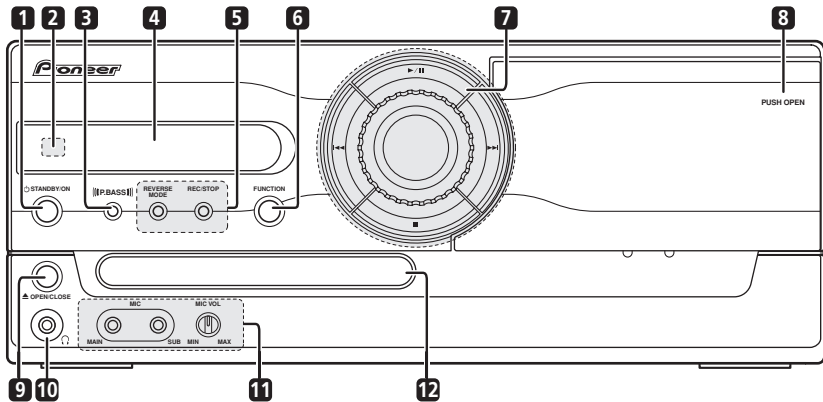
**1** **STANDBY/ON**

Switches the player on or into standby.

2 **Remote sensor****3** **P.BASS**

Press to switch on the bass boost (page 27).

4 **Display**

See *Display* below.

5 **Tape cassette controls**

REVERSE MODE – Selects the playback mode for tapes (page 16).

REC/STOP – Starts/stops recording on the tape deck (page 24).

6 **FUNCTION**

Selects the source you want to listen to.

7 **Playback / volume control**

The playback controls are used for playing, pausing, skipping and stopping playback. Turn the middle section to adjust the volume.

8 **PUSH OPEN**

Press down on this side of the cassette door to open the tape deck.

9 **OPEN/CLOSE**

Ejects the disc.

10 **Headphone jack****11** **MIC VOL and MIC input jacks**

Controls the volume of the karaoke mics (**MAIN** and **SUB**) (page 26).

12 **Disc tray**

Display

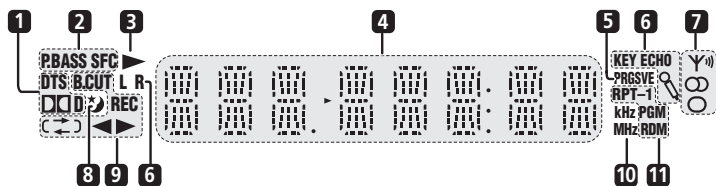

1 Format indicators

- DTS** – Lights during playback of a DTS source.
- D** – Lights during playback of a Dolby Digital source.

2 Sound processing indicators (page 27)

- P.BASS** – Lights when the bass boost is switched on.
- SFC** – Lights when one of the Sound Field Control modes is selected.

3 ▶

Lights during playback.

4 Character display

5 PRGSVE

Lights when the player is set to output progressive scan video (page 8).

6 Karaoke indicators (page 26)

- ECHO** – Lights when the Karaoke **ECHO** effect is selected.
- KEY** – Lights when the Karaoke pitch control is selected.
- Ⓚ** (Vocal cancel) – Vocals in the backing track are partially eliminated using EQ.
- L** – Left channel only. Use for tracks that have a vocal recorded in the right channel.
- R** – Right channel only. Use for tracks that have a vocal recorded in the left channel.
- LR** – Use to put a single-channel vocal track into the center of the mix.

7 Tuner indicators

- Y^{FM}** – Lights when a broadcast is being received.

Ⓚ – Lights when a stereo FM broadcast is being received in auto stereo mode.

○ – Lights when FM mono reception is selected (page 25).

8 ★

Lights when the sleep timer is active (page 17).

9 Cassette deck indicators

- B.CUT** – Lights when the beat cut mode has been switched to **B.CUT 2** (page 33).
- REC** – Lights when recording to the tape deck (page 24).
- ◀▶** – Indicates the direction of tape playback.
- ↺↻** – Indicates the reverse mode (page 16).

10 kHz / MHz

Indicates the unit of the frequency shown in the display (**kHz** for AM, **MHz** for FM).

11 Playback mode indicators

- RPT-1** – **RPT** lights during repeat play (**RPT-1** lights during repeat one-track/chapter play) (page 20).
- PGM** – Lights during program play (page 21).
- RDM** – Lights during random playback (page 21).

Remote control

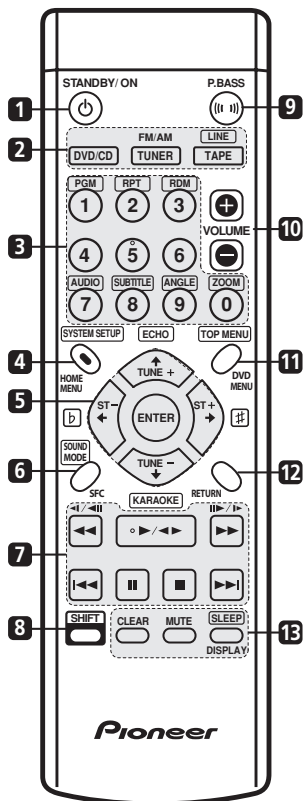

1 STANDBY/ON

Switches the player on or into standby.

2 Input source function select

Selects the source you want to listen to: **DVD/CD**, **TUNER**, **TAPE** or **LINE (SHIFT+TAPE)**.

3 Number buttons and SHIFT functions

The number buttons can be used for selecting titles/chapters/tracks directly, the functions above the buttons are accessed by pressing **SHIFT** at the same time as the button.

PGM (SHIFT+1) – Use to program/play a program list (page 21).

RPT (SHIFT+2) – Selects a repeat play mode (page 20).

RDM (SHIFT+3) – Selects a random play mode (page 21).

AUDIO (SHIFT+7) – Selects the audio channel or language (page 23).

SUBTITLE (SHIFT+8) – Selects a subtitle display (page 23).

ANGLE (SHIFT+9) – Changes the camera angle during DVD multi-angle scene playback (page 23).

ZOOM (SHIFT+0) – Changes the zoom level (page 23).

4 HOME MENU

Press to display (or exit) the on-screen menu for Initial Settings, Play Mode functions, etc.

SYSTEM SETUP (SHIFT+HOME MENU)

Use to make various system settings (page 33). Also used to save station presets (page 17 and page 25) and select mono FM reception (page 25) when using the tuner.

5 Cursor buttons, ENTER, tuning and karaoke buttons

Cursor buttons – Use the cursor buttons () to navigate on-screen displays and menus.

ENTER – Selects an option or executes a command.

TUNE (+/-) –Tunes the radio.

ST (+/-) – Selects station presets when listening to the radio.

The karaoke functions are accessed by pressing **SHIFT** at the same time as the corresponding button:

KARAOKE (SHIFT+↓) – Selects audio channels for karaoke (page 26).

ECHO (SHIFT+↑) – Changes the echo level on the karaoke mics (page 26).

Key controls **b** and **# (SHIFT+←/→)** – Lowers/raises the pitch of the backing track (page 26).

6 SFC

Selects sound modes or custom settings from the Sound Field Control (page 27).

SOUND MODE (SHIFT+SFC)

Accesses settings in the Sound menu, such as the tone controls (page 27).

7 Playback controls

See *Playing discs* on page 14, *Playing cassette tapes* on page 16, and *Disc playback features* on page 18 for an explanation of these controls.

8 SHIFT

Some of the buttons have alternate functions (they are outlined on the remote control). Press and hold **SHIFT** to access these.

9 P.BASS

Press to switch on the bass boost (page 27).

10 VOLUME

Adjusts the volume level.

11 DVD MENU

Press to display a DVD disc menu, or the Disc Navigator (page 15).

TOP MENU (SHIFT+DVD MENU)

Displays the top menu of a DVD disc in the play position—this may be the same as pressing **DVD MENU** (page 15).

12 RETURN

Press to return to a previous menu screen.

13 CLEAR

Clears an entry.

MUTE

Mutes the volume (page 27).

DISPLAY

Switches between information displays (page 23).

SLEEP (SHIFT+DISPLAY) – Use for setting the sleep timer (page 17).

Range of the remote control unit

The remote control has a range of about 7 meters at an angle of 30° of the remote control sensor. It may not work properly if:

- There are obstacles between the remote control and this unit's remote sensor.
- Direct sunlight or fluorescent light is shining onto the remote sensor.
- This system is located near a device that is emitting infrared rays.
- This unit is operated simultaneously with another infrared remote control unit.

Chapter 4

Getting started

Using the on-screen displays

For ease of use, this system makes extensive use of graphical on-screen displays (OSDs).

All the screens are navigated in basically the same way, using the cursor buttons (↑ / ↓ / ← / →) to change the highlighted item and pressing **ENTER** to select it.¹



Important

- Throughout this manual, 'Select' means use the cursor buttons to highlight an item on-screen, then press **ENTER**.

Button	What it does
HOME MENU	Displays/exits the on-screen display
← ↑ ↓ →	Changes the highlighted menu item
ENTER	Selects the highlighted menu item
RETURN	Returns to the main menu without saving changes



Tip

- The button guide at the bottom of every OSD screen shows you which buttons you'll need to use for that screen.

Playing discs

The basic playback controls for playing DVD, CD, Video CD/Super VCD, DivX video and MP3/WMA discs are covered here. Further functions are detailed in chapter 5.

1 If the player isn't already on, switch it on.

If you're playing a DVD, Video CD/Super VCD or DivX video, also turn on your TV and make sure that it is set to the correct video input.

2 Press ▲ on the front panel to load a disc.

Load a disc with the label side facing up, using the disc tray guide to align the disc (if you're loading a double-sided DVD disc, load it with the side you want to play face down).



3 Press ► (play) to start playback.

If you're playing a DVD or Video CD/Super VCD, a menu may appear. See *DVD-Video disc menus* on page 15 and *Video CD/Super VCD PBC menus* on page 16 to navigate these.

If you're playing a DivX video or WMA/MP3 disc, it may take a few seconds before playing.

If you loaded a CD/CD-R/RW containing JPEGs, a slideshow will start. See *Playing a JPEG slideshow* on page 18 for more on this.

Note

¹ The screen saver will appear after five minutes of inactivity.

- If a disc contains a mixture of DivX video and other media file types (MP3, for example), first select whether to play the DivX video files (**DivX**) or the other media file types (**MP3 / WMA / JPEG**) from the on-screen display.

4 Adjust the volume.

Use the **VOLUME +/-** control.

Basic playback controls

The following table shows the basic controls on the remote for playing discs¹. You can find other playback features in the chapter 5.

Button	What it does
▶	Starts/resumes normal playback. <ul style="list-style-type: none"> • If the display shows RESUME or LAST MEM playback starts from the resume or last memory point (see <i>Resume and Last Memory</i> below).
⏸	Pauses/unpauses a disc.
■	Stops playback or cancels the resume function (if the display shows RESUME).
◀◀	Press to start fast reverse scanning.
▶▶	Press to start fast forward scanning.
◀◀	Skips to the start of the current track or chapter, then previous tracks/chapters.
▶▶	Skips to the next track or chapter.
Numbers	Use to enter a title/chapter/track number. Press ENTER to select. <ul style="list-style-type: none"> • If the disc is stopped, playback starts from the selected title (for DVD) or track (for CD/Video CD/Super VCD). • If the disc is playing, playback jumps to the start of the selected title (VR mode DVD-RW), chapter (DVD-Video) or track (CD/Video CD/Super VCD).

Resume and Last Memory

When you stop playback of a disc, **RESUME** shows in the display indicating that you can resume playback from that point.

With DVDs and Video CD/Super VCDs, even if ejected, the play position is stored in memory.² The next time you load the disc, the display shows **LAST MEM** and you can resume playback.

If you want to clear the resume point, press ■ (stop) while **RESUME** is displayed.

DVD-Video disc menus

Many DVD-Video discs contain menus from which you can select what you want to watch.

Sometimes DVD-Video menus are displayed automatically when you start playback; others only appear when you press **DVD MENU** or **TOP MENU (SHIFT+DVD MENU)**.

Button	What it does
TOP MENU (SHIFT+DVD MENU)	Displays the 'top menu' of a DVD disc—this varies with the disc.
DVD MENU	Displays a DVD disc menu—this varies with the disc and may be the same as the 'top menu'.
← ↑ ↓ →	Moves the cursor around the screen.
ENTER	Selects the current menu option.
RETURN	Returns to the previously displayed menu screen.
Numbers	Highlights a numbered menu option (some discs only). Press ENTER to select.

Note

¹ You may find with some DVD discs that some playback controls don't work in certain parts of the disc.

² The Last Memory function may not work with some discs.

- For DVD-Video discs (except VR mode DVD-RW), the player stores the play position of the last five discs.

Video CD/Super VCD PBC menus

Some Video CD/Super VCDs have menus from which you can choose what you want to watch. These are PBC (Playback control) menus.

You can play a PBC Video CD/Super VCD without having to navigate the PBC menu by starting playback using a number button to select a track, rather than the ► (play) button.

Button	What it does
RETURN	Displays the PBC menu.
Numbers	Selects numbered menu options. Press ENTER to select.
◀◀	Displays the previous menu page (if there is one).
▶▶	Displays the next menu page (if there is one).

Playing cassette tapes

This unit has a tape deck that can be used for both recording and playback. In addition, it features automatic music search (AMS) and auto-reverse functions¹. See *Manual recording to cassette* on page 24 for more features.

1 Push down on the cassette door where indicated to open it and insert a tape.

2 Close the cassette door.

3 Press REVERSE MODE (front panel only) to select the reverse mode.

Press repeatedly to choose between:

- ◄ – Single side playback
- ◄↔ – Auto-reverse playback: stops after finishing playback in the 'reverse' (◄) direction
- ◄↔ – Continuous playback (up to 8 complete plays)

4 Press TAPE to start playback.

You can also press ◀▶ (remote) or ▶/|| (front panel) to start playback when **TAPE** is selected. The side of the tape you'll hear is whichever is face up when you load it. This is the 'forward' (▶) direction, while the other side is 'reverse' (◄). The direction indicator is shown in the display.

Basic playback controls

The following table shows the basic controls on the remote for playing cassette tapes.

Button	What it does
TAPE (◀▶)	Starts/resumes normal playback. Each time you press either button during playback, the other side of the tape starts playing. Pressing TAPE (or ◀▶) when the tape is stopped starts playback on the side it was playing previously.
 	Pauses playback.
■	Stops playback. Also resets the tape counter to 0000 if pressed when the tape is already stopped.
◀◀	Press to fast-rewind a tape.
▶▶	Press to fast-forward a tape.
◀◀ / ▶▶ ^a	Searches for the previous / next blank space between tracks on the side currently playing (in other words, to the start of the current / next track), then resumes playback. By pressing more than once, the tape will skip several tracks at once (up to a maximum of 15). For example, press ▶▶ twice to skip forward two tracks.

a. Track search is unlikely to work reliably if:

- the space between tracks is less than about 4 seconds.
- the recording is noisy so the spaces are not recognized.
- the recording contains frequent silences, such as a language study tape.
- the recording contains sections of very quiet material, such as some classical music recordings.

Note

¹ The auto-reverse feature lets you play or record a tape without physically taking it out and turning it over.

Listening to the radio

Use the auto station preset feature explained below to memorize and recall the AM and FM radio stations in your area (to tune manually, see *Manual tuner features* on page 25).

Automatically saving station presets

1 Press **TUNER (FM/AM)** to select the tuner.

2 Press **SYSTEM SETUP (SHIFT+HOME MENU)**, use **←/→** to choose 'A. PRSET' then press **ENTER**.

Auto tuning starts in the FM band, stopping when a strong signal is received.

3 When auto tuning stops at a station, press **ENTER** to save the station as a preset, or press **↑/↓** to continue without saving.

Auto tuning resumes. After the FM band is finished, auto tuning continues in the AM band. Press **■** (stop) anytime to exit.

Auto tuning stops automatically after the AM band is finished, or after the limit of 30 presets has been reached. When this happens, the tuner automatically switches to preset **ST-1**.

Listening to station presets

1 Press **TUNER (FM/AM)** to select the tuner.

2 Use the **ST +/-** buttons to select a preset.

- You can also use the number buttons and **ENTER** to do this.

Listening to other sources

You can connect an external source for playback through this system's speakers. See *Connecting auxiliary components* on page 9 for more on this.

- Make sure that the external source (TV, MD player, etc.) is switched on.
- Press **LINE (SHIFT+TAPE)** to select the source connected to the rear panel **LINE** input.
- If necessary, start playback of the source.
 - Note that this source is not output from the **LINE OUT** auxiliary jacks.

Setting the sleep timer

The sleep timer dims the display and switches off the system after a specified time so you can fall asleep without worrying about it.

- Press **SLEEP (SHIFT+DISPLAY)** repeatedly to select a switch-off time.

Choose between the following options:

- OFF** – Cancels the sleep timer
- SLEEP 30** – Switches off after 30 minutes
- SLEEP 60** – Switches off after an hour
- SLEEP 90** – Switches off after 90 minutes
- AUTO** – Switches off automatically after the currently playing CD, Video CD, DivX video or tape has finished.¹

To check the current setting, press **SLEEP (SHIFT+DISPLAY)** once.

Note

¹ • **AUTO** will not work with DVD/CDs in repeat play, cassette tapes in endless mode, WMA/MP3s or Video CD/Super VCDs during PBC playback.

- The system will switch into standby after a minute if you change the input function during **AUTO** sleep mode.

Chapter 5

Disc playback features

**Important**

- Many of the functions covered in this chapter apply to DVD discs, Video CDs/Super VCDs, CDs, DivX video and WMA/MP3/JPEG discs, although the exact operation of some varies slightly with the kind of disc loaded.
- Some DVDs restrict the use of some functions (random or repeat, for example) in some or all parts of the disc. This is not a malfunction.
- When playing Video CD/Super VCDs, some of the functions are not available during PBC playback. If you want to use them, start the disc playing using a number button to select a track.

Scanning discs

You can fast-scan discs forward or backward at various different speeds.¹

- **During playback, press ◀◀ or ▶▶ to start scanning.**

Press repeatedly to increase the scanning speed (shown on-screen).

- To resume playback, press ▶ (play).²

Playing in slow motion

You can play DVDs, Video CD/Super VCDs and DivX video at four different forward slow motion speeds. DVD discs can also be played in reverse slow motion.

- 1 **During playback, press II (pause).**

- 2 **Press and hold ◀◀ or ▶▶ until slow motion playback starts.**

Press repeatedly to change the slow motion speed (shown on-screen).

- To resume playback, press ▶ (play).²

Frame advance/frame reverse

You can advance or back up DVD discs frame-by-frame. With Video CD/Super VCDs and DivX video you can only use frame advance.

- 1 **During playback, press II (pause).**

- 2 **Press ◀◀ or ▶▶ to reverse or advance a frame at a time.**

- To resume playback, press ▶ (play).²

Playing a JPEG slideshow

After loading a CD/CD-R/RW containing JPEG pictures, press ▶ to start a slideshow from the first folder/picture on the disc.³ The player displays the pictures in each folder in alphabetical order.

Pictures are automatically adjusted so that they fill as much of the screen as possible.

While the slideshow is running:

Button	What it does
II	Pauses the slideshow; press again to restart.
◀◀	Displays the previous picture.

Note

¹ Only one speed is available for DivX video discs.

² Depending on the disc, normal playback may automatically resume when a new chapter is reached on a DVD disc.

• With Video CD/Super VCDs in PBC mode or a WMA/MP3 track, playback automatically resumes at the end or beginning of the track.

³ The time it takes for the player to load a file increases with large file sizes.

Button	What it does
▶▶	Displays the next picture.
◀/→/↑/↓	Pauses the slideshow and rotates/flips the displayed picture. (Press ▶ (play) to restart slideshow).
ZOOM (SHIFT+0)	Pauses the slideshow and zooms the picture. Press again to toggle between 1x, 2x and 4x zoom. (Press ▶ (play) to restart slideshow).
DVD MENU	Displays the Disc Navigator screen (see below).

Browsing DVD or Video CD/ Super VCD discs with the Disc Navigator

Use the Disc Navigator to browse through the contents of a DVD or Video CD/Super VCD disc to find the part you want to play.

- 1 During playback, press **HOME MENU** and select 'Disc Navigator' from the on-screen menu.

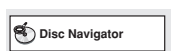

- 2 Select a view option.

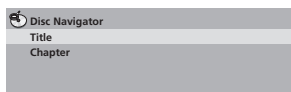

The options available depend on the kind of disc loaded and whether the disc is playing or not, but include:

- **Title** – Titles from a DVD-Video disc.
- **Chapter** – Chapters from the current title of a DVD-Video disc.
- **Track** – Tracks from a Video CD/Super VCD disc.

- **Time** – Thumbnails from a Video CD/Super VCD disc at 10 minute intervals.
- **Original: Title** – Original titles from a VR mode DVD-RW disc.
- **Playlist: Title** – Playlist titles from a VR mode DVD-RW disc.
- **Original: Time** – Thumbnails from the Original content at 10 minute intervals.
- **Playlist: Time** – Thumbnails from the Playlist at 10 minute intervals.

The screen shows up to six thumbnail images displayed one after another. To display the previous/next six thumbnails, press ◀◀/▶▶.

- 3 Select the thumbnail image for what you want to play.

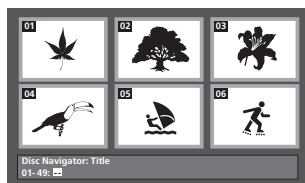

To select using the number buttons, enter a two-digit number then press **ENTER**.

You can use either the cursor buttons (↑/↓/←/→) and **ENTER** to select a thumbnail, or the number buttons.

Browsing WMA, MP3, DivX video and JPEG files with the Disc Navigator

Use the Disc Navigator to find a particular file or folder by filename.

1 Press HOME MENU and select 'Disc Navigator' from the on-screen menu.

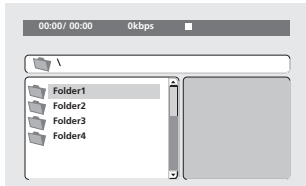

2 Use ↑/↓/←/→ and ENTER to navigate.

Use the cursor up/down buttons (↑/↓) to move up and down the folder/file list.

Use the cursor left button (←) to return to the parent folder.¹

Use **ENTER** or cursor right (→) to open a highlighted folder.

- When a JPEG file is highlighted, a thumbnail image is displayed on the right.

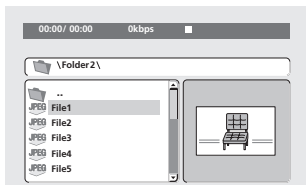

3 To play the highlighted track or DivX video file or display the highlighted JPEG file, press ENTER.

- When a WMA/MP3 or DivX video file is selected, playback begins from that file, and continues until the end of the folder.
- When a JPEG file is selected, a slideshow begins, starting with that file, and continues to the end of the folder.

Tip

- To play the contents of the whole disc rather than just the current folder, exit the Disc Navigator and start playback using the ► (play) button.

Looping a section of a disc

The A-B Repeat function allows you to specify two points (A and B) within a track (CD, Video CD/Super Video CD) or title (DVD) that form a loop which is played over and over.

1 During playback, press HOME MENU and select 'Play Mode'.

2 Select 'A-B Repeat'.²

3 Press ENTER on 'A(Start Point)' to set the loop start point.

4 Press ENTER on 'B(End Point)' to set the loop end point.

After pressing **ENTER**, playback jumps back to the start point and plays the loop.

5 To resume normal playback, select 'Off'.

Using repeat play

In addition to various repeat play options, it's also possible to use repeat play together with program play (see *Creating a program list* on page 21).

1 During playback, press HOME MENU and select 'Play Mode'.

2 Select 'Repeat' then select a repeat play option.³

If program play is active, select **Program Repeat** to repeat the program list, or **Repeat Off** to cancel.

Note

¹ You can also do this by going to the '..' folder at the top, then pressing **ENTER**.

² You can't use A-B Repeat play with WMA/MP3 or DivX video discs.

³ You can't use repeat play with WMA/MP3 discs.

Disc playback features

- For DVD discs, select **Title Repeat**, **Chapter Repeat** or **Repeat Off**.
- For CDs and Video CD/Super VCDs, select **Disc Repeat**, **Track Repeat** or **Repeat Off**.
- For DivX video discs, select **Repeat Title** (or **Repeat Off**).



Tip

- You can also use the **RPT (SHIFT+2)** button on the remote to select a repeat play option. The repeat modes available are the same as those from the **Play Mode** menu.

Using random play

Use this function to play titles or chapters (DVD-Video) or tracks (CD and Video CD/Super VCD) in a random order.¹

1 During playback, press HOME MENU and select 'Play Mode'.

2 Select 'Random' then select an option.

- For DVD discs, select **Random Title**, **Random Chapter** or **Random Off**.
- For CDs and Video CD/Super VCDs, select **On** or **Off** to switch random play on or off.



Tip

- Use the following controls during random play:

Button	What it does
▶▶	Selects a new track/title/chapter at random.

Button	What it does
◀◀	Returns to the beginning of the current track/title/chapter; further presses select another random track/title/chapter.

- You can also use the **RDM (SHIFT+3)** button on the remote to select a random play mode. The random modes available are the same as when choosing from the **Play Mode** menu. Press **ENTER** to start random play.
- Random play remains in effect until you select **Random Off** from the random play menu options.

Creating a program list

This feature lets you program the play order of titles/chapters/tracks on a disc.²

Using the OSD

1 During playback, press HOME MENU and select 'Play Mode'.

2 Select 'Program' then select 'Create/Edit' from the list of program options.

3 Use the cursor buttons and ENTER to select a title, chapter or track for the current step in the program list.

For a DVD disc, you can add a title or a chapter.

- For a CD or Video CD/Super VCD, select a track to add to the program list.

After pressing **ENTER** to select the title/chapter/track, the step number automatically moves down one.

4 Repeat step 3 to build up a program list.

A program list can contain up to 24 steps.

Note

¹ • You can set the random play option when a disc is playing or stopped. However, you can't use random play together with program.

• You can't use random play with VR format DVD-RW discs, WMA/MP3 discs, DivX video discs, or while a DVD disc menu is being displayed.

² You can't use Program play with VR format DVD-RW discs, WMA/MP3 discs, DivX video discs, or while a DVD disc menu is being displayed.

- You can insert steps by just highlighting the position where you want the new step to appear and entering a title/chapter/track number.
- To delete a step, highlight it and press **CLEAR**.

5 To play the program list, press ► (play).

Program play remains active until you turn off program play (see below), erase the program list (see below), eject the disc or switch off.



Tip

- Use the following controls during program play:

Button	What it does
HOME MENU	Save the program list and exit without starting playback.
►►	Skip to the next step in the program list.

Other functions available from the program menu

There are a number of other options in the program menu in addition to Create/Edit.

- **Playback Start** – Starts playback of a saved program list
- **Playback Stop** – Turns off program play, but does not erase the program list
- **Program Delete** – Erases the program list and turns off program play

Using the front panel display

Even though the OSD is available for CDs, the front panel display provides information to make a program list easily. If a disc is playing, stop it first.

1 Press PGM (SHIFT+1).

You're prompted to enter a track for the first step in the program list.

2 Use the number buttons to select a track, then press ENTER.

If you make a mistake, press **CLEAR** to delete the last (most recently) programmed track.

3 Repeat step 2 to build up a program list.

A program list can contain up to 24 steps.

4 To play the program list, press ► (play).

- Program play remains active until you press ■ (stop), clear the playlist (see above), eject the disc or switch off the player.

Searching a disc

You can search DVD discs by title or chapter number, or by time; CDs and Video CD/Super VCDs by track number or time; DivX video discs by time.

1 Press HOME MENU and select 'Play Mode'.

2 Select 'Search Mode'.

The search options that appear depend on the kind of disc loaded.

3 Select a search mode.

- The disc must be playing in order to use time search.

4 Use the number buttons to enter a title, chapter or track number, or a time.

- For a time search, enter the number of minutes and seconds into the currently playing title (DVD/ DivX video) or track (CD/ Video CD/Super VCD) you want playback to resume from. For example, press **4, 5, 0, 0** to have playback start from 45 minutes into the disc. For 1 hour, 20 minutes and 30 seconds, press **8, 0, 3, 0**.

5 Press ENTER to start playback.

Disc playback features

Switching subtitles

Some DVD discs and DivX video discs have subtitles in one or more languages; the disc box will usually tell you which subtitle languages are available. You can switch subtitle language during playback.¹

- **Press SUBTITLE (SHIFT+8) repeatedly to select a subtitle option.**
 - To set subtitle preferences, see *Language settings* on page 29.
 - See *Displaying DivX subtitle files* on page 36 for more on DivX subtitles.

Switching language / audio channels

When playing discs recorded with dialog in two or more languages, or with dual-mono audio² you can switch these during playback.³

- **Press AUDIO (SHIFT+7) repeatedly to select an audio language option.**
 - To set audio language preferences, see *Language settings* on page 29.

Zooming the screen

Using the zoom feature you can magnify a part of the screen by a factor of 2 or 4, while watching a DVD, DivX video title or Video CD/Super VCD or playing a JPEG disc.

- 1 **During playback, use the ZOOM (SHIFT+0) button to select the zoom factor (Normal, 2x or 4x).**

- 2 **Use ↑/↓/←/→ to change the zoomed area.**

You can change the zoom factor and the zoomed area freely during playback.⁴

Switching camera angles

Some DVD discs feature scenes shot from two or more angles—check the disc box for details.

When a multi-angle scene is playing, a  icon appears on screen (this can be switched off if you prefer—see *Display settings* on page 30).

- **During playback (or when paused), press ANGLE (SHIFT+9) to switch the angle.**

Displaying disc information

Various track, chapter and title information can be displayed on-screen during playback.

- **To show/switch/hide the information displayed, press DISPLAY repeatedly.** Limited disc information also appears in the front panel display. Press **DISPLAY** to change the displayed information.

Note

- 1 Some discs only allow you to change subtitle language from the disc menu. Press **TOP MENU** or **DVD MENU** to access.
- 2 Some Super VCDs have two soundtracks. With these discs you can switch between the two soundtracks as well as individual channels in each.
- 3 Some discs only allow you to change audio language from the disc menu. Press **TOP MENU** or **DVD MENU** to access.
- 4 • Since DVD, Video CD/Super VCD, DivX video title and JPEG pictures have a fixed resolution, picture quality will deteriorate, especially at 4x zoom. This is not a malfunction.
 - If the navigation square at the top of the screen disappears, press **ZOOM** again to display it.

Chapter 6

Making tape recordings

Manual recording to cassette

You can make tape recordings from the radio, CDs, or from an external component connected to the auxiliary inputs.¹

Unlike some tape decks, there's no need to set recording levels; the deck sets the level automatically. When recording, the volume (as well as all other sound processing features²) has no effect on the recording. This means that you can record something with the volume turned right down if you want.

1 Press TAPE then load a cassette into the tape deck.

In order to follow these instructions more easily, load the cassette³ with side A facing up, then use the front panel controls.

2 Check the recording direction.

If you start recording in the ► direction, both sides of the tape can be recorded (unless the erase protect tab for side B is missing). If you switch sides and start recording in the ◀ direction, then recording will start from side B and stop when the end of the tape is reached. If you need to change the direction, press ►/|| (◀►) twice, then ■ (stop).

3 Set the reverse mode (page 16).

- ◄► (record one side only)

- ◄► or ◄◄ (record both sides if recording starts in the ► (forward) direction, or one side if recording starts in the ◀ (reverse) direction)

4 Select the source you want to record.

For example, press **TUNER (FM/AM)** to record from the radio. If you've selected a CD, make sure that it's stopped. You can't record while **TAPE** is selected.

5 Prepare the source for recording.

For example, tune in the radio station.⁴

6 Press REC/STOP (front panel only).

The **REC** indicator lights in the display and the deck starts recording.

7 Start the source playing (if necessary).

8 When you're ready to stop recording, press REC/STOP again.



Tip

- If you find that you're getting noisy recordings from an AM radio station, see *Using the System Setup menu* on page 33 to change the beat cut mode.

Note

¹ Once recording has started, you can't switch to another component until recording has stopped. So, for example, you can't switch over to the tuner while you're recording a CD.

² During recording, sound processing features (such as the sound menu settings, SFC effects, karaoke features and the bass boost) are not available.

³ • Before recording, check that the cassette erase-protect tabs have not been broken, and that the tape is Type I (normal position). You can't record on Type II (high/CrO₂) or IV (metal) tapes using this deck.

• If you're recording from the start of a tape, it's a good idea to wind the tape on a little so that you don't accidentally start recording over the leader tape. You can either do this by hand, or load the tape into the deck and play the tape for 5–6 seconds.

⁴ Once recording has started, you won't be able to change the frequency (or use the tuner features such as FM mono).

Chapter 7

Manual tuner features

Selecting stations manually

1 Press TUNER (FM/AM) to switch to the tuner, then press repeatedly to select the AM or FM band.

The display shows the band and frequency.

2 Tune to a frequency.

There are three tuning modes—step, auto, and high-speed:

- **Step tuning:** Press **TUNE +/-** repeatedly to change the displayed frequency.
- **Auto tuning:** Press and hold **TUNE +/-** until the frequency display starts to move, then release. The tuner will stop on the next station it finds. Repeat to keep searching.
- **High-speed tuning:** Press and hold **TUNE +/-** until the frequency display starts to move rapidly. Keep the button held down until you reach the frequency you want. If necessary, fine tune the frequency using the manual tuning method.

Manually saving station presets

In addition to *Automatically saving station presets* on page 17, you can manually select which stations you want to add.

1 Tune to an AM or FM radio station.

For the FM band, select mono or auto-stereo reception as necessary. This setting is saved along with the preset.

2 Press SYSTEM SETUP (SHIFT+HOME MENU), use ←/→ to choose 'ST. MEM.' then press ENTER.

3 Use ↑/↓ to select the preset you want then press ENTER.

The station is stored under the preset number (1–30) you selected.

Improving FM stereo sound

If you're listening to an FM station in stereo but the reception is weak, you can improve the sound quality by switching to mono.

1 Make sure you're tuned to an FM station.

2 Press SYSTEM SETUP (SHIFT+HOME MENU), use ←/→ to choose FM MODE then press ENTER.

3 Use ↑/↓ to select FM MONO then press ENTER.

The  indicator lights when the tuner is in mono reception mode.

- Select **FM AUTO** above to switch back to auto-stereo mode (the  indicator lights when receiving a stereo broadcast).

Chapter 8

Singing karaoke

Singing karaoke

Using the karaoke features you can plug in a microphone and mix the sound of your own voice with a backing track. The backing track can be anything you like, from a song on the radio, to a dedicated DVD karaoke disc. Adjust the microphone level relative to the backing track.

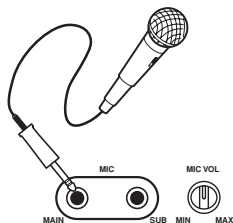

1 Set the MIC VOL knob (front panel) to minimum.

2 Plug in the microphone(s).

If you're only using one mic, plug it into the **MIC (MAIN)** jack. The **MIC (SUB)** jack can be used only if **MIC (MAIN)** is also connected.

- If the microphone has an on/off switch, make sure it's on.

3 Load a karaoke backing disc or tape.

You can also use the radio or a component connected to the auxiliary inputs as source material for a backing track.

4 To change the mix, press KARAOKE (SHIFT+↓).

Press to switch between these options:¹

- **KARAOKE** (Vocal cancel) – Backing track vocals are partially eliminated using EQ.
- **L CH** – Left channel only. Use for tracks that have a vocal recorded in the right channel.
- **R CH** – Right channel only. Use for tracks that have a vocal recorded in the left channel.
- **L+R CH** – Use to put a single-channel vocal track into the center of the mix.
- **OFF** – Switches the Karaoke mode off.

5 Play the backing track.

6 Adjust the MIC VOL knob.

To avoid unpleasant feedback, make sure you don't point the microphone(s) at the speakers.²

7 Sing!

Changing the vocal mix

Adding some effects to the microphone mix can sometimes improve the overall sound. You can choose between three echo levels.

- To add effects to the microphone mix, press **ECHO (SHIFT+↑)**.

Pressing repeatedly switches between echo levels 1 to 3 and off.

Changing the backing track

You may want to lower or raise the pitch of the backing track to match your vocal range.³

- Press **KEY CONTROL b (SHIFT + ←)** or **# (SHIFT + →)** to lower or raise the pitch of the backing track.

 **Note**

¹ The current setting is first shown in the display.

² Depending on the microphone level, the sound of the disc may distort. If this happens, turn down the volume.

³ • This is only available when the **DVD/CD** input source is selected.

- This feature is not available during playback of DTS-encoded sources.

Chapter 9

Adjusting the sound

Using the Sound menu

There are several optional sound settings you can make from the sound menu.

- 1 Press **SOUND MODE (SHIFT+SFC)**.
- 2 Use **←/→** to choose the setting you want to adjust.

The current setting is shown for each option (in the order shown in step 3) as you cycle through the display.

- If selecting an SFC memory (**SFC MEM**) press **ENTER** to continue to the next step.

- 3 Use **↑/↓** to adjust (or select) the setting. Make adjustments to the following settings:

Setting	What it does	Option(s)
Bass	Adjusts the amount of bass.	-4 to +4
Treble	Adjusts the amount of treble.	-4 to +4
Stereo Wide	Makes the stereo spread appear wider than it really is	OFF ON
SFC Memory	Stores your current bass, treble and stereo-wide settings as a preset.	USER 1 USER 2

- 4 Repeat steps 2 and 3 for other settings.
 - Skip this step if selecting an SFC memory.
- 5 When you're done, press **ENTER** to confirm and leave the Sound menu.

Using the Sound Field Control

Depending on the source you're listening to, you may want to use the Sound Field Control to match the source you're listening to.

- Press **SFC** repeatedly to select a mode. The options are as follows:
 - **ACTION** – Good for sound effects.
 - **DOME** – Gives a 'live' feel to the sound.
 - **DRAMA** – Good for enhancing dialogue.
 - **KARAOKE** – Reduces the level of vocal tracks on pre-recorded music.
 - **USER 1 / 2** – See *Using the Sound menu* above.
 - **SFC OFF** – (**SFC** indicator disappears)

Boosting the bass level

If you want to bring up the low end for certain kinds of music or sound sources, you can use the bass boost to do so.

- Press **P.BASS** to switch the bass boost on (**P.BASS 1**) or off (**P.BASS 0**).

Muting the sound

- Press **MUTE** to switch off the volume. To switch the sound back on, adjust the volume or press **MUTE** again.

Chapter 10

Audio Settings and Video Adjust menu

Audio Settings menu

The Audio Settings menu offers features for adjusting the way discs sound.

- 1 Press **HOME MENU** and select 'Audio Settings' from the on-screen display.



- 2 Make settings using **↑/↓/←/→** and **ENTER**.

Virtual Surround

- Settings: **On, Off** (*default*)

Switch on Virtual Surround to enjoy realistic surround sound effects from just two speakers.¹

Audio DRC

- Settings: **Low, Medium, High, Off** (*default*)

When watching Dolby Digital DVDs at low volume, it's easy to lose the quieter sounds completely—including some of the dialog. Switching Audio DRC (Dynamic Range Control) to on can help by bringing up the quieter sounds, while controlling loud peaks.

How much of a difference you hear depends on the material you're listening to. If the material doesn't have wide variations in volume, you may not notice much change.²

Video Adjust menu

From the Video Adjust screen you can adjust various settings that affect how the picture is presented.

- 1 Press **HOME MENU** and select 'Video Adjust' from the on-screen display.

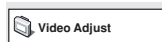

- 2 Make settings using **↑/↓/←/→** and **ENTER**.

You can adjust these picture quality settings:

- **Sharpness** – Adjusts the sharpness of edges in the picture (**Fine, Standard, Soft**).
- **Brightness** – Adjusts the overall brightness (**-20 to +20**).
- **Contrast** – Adjusts the contrast between light and dark (**-16 to +16**).
- **Gamma** – Adjusts the 'warmth' of the picture (**High, Medium, Low, Off**).
- **Hue** – Adjusts the red/green balance (**Green 9 to Red 9**).
- **Chroma Level** – Adjusts how saturated colors appear (**-9 to +9**).

Adjust the Brightness, Contrast, Hue and Chroma Level settings using **←/→**.



- 3 Press **ENTER** to return to the **Video Adjust** screen, or **HOME MENU** to exit.

Note

¹ How good the surround effect is varies with the disc.

² The effect of Audio DRC also depends on your speakers and settings.

Chapter 11

Initial Settings menu

Using the Initial Settings menu

The Initial Settings menu provides audio and video output settings, parental lock settings, and display settings, among others.

If an option is grayed out it means that it cannot be changed at the current time. This is usually because a disc is playing. Stop the disc, then change the setting.

1 Press **HOME MENU** and select 'Initial Settings'.



2 Use the cursor buttons and **ENTER** to select the setting and option you want to set. All the settings and options are explained on the following pages.¹

Video Output settings

Setting	Option	What it means
TV Screen (See also <i>Specifications</i> on page 43.)	4:3 (Letter Box)	Set if you have a conventional 4:3 TV. Widescreen movies are shown with black bars top and bottom.
	<i>4:3 (Pan & Scan)</i>	Set if you have a conventional 4:3 TV. Widescreen movies are shown with the sides cropped so that the image fills the screen.
	<i>16:9 (Wide)</i>	Set if you have a widescreen TV.
Component Out (See also <i>Connecting using component video</i> on page 8.)	Interlace	Set if your TV is not compatible with progressive scan video.
	<i>Progressive</i>	Set if your TV is compatible with progressive scan video (see your TV's instruction manual for details). Press ENTER once more to confirm (or RETURN to cancel). If you lose the picture on your TV, refer to <i>Interlace setting in System Setup menu options in standby</i> on page 33. <i>Note that progressive scan video is only output from the component video jacks.</i>

Language settings

Setting	Option	What it means
Audio Language	English	If there is an English soundtrack on the disc, it is played.
	<i>Languages as displayed</i>	If there is a language selected on the disc, it is played.
	<i>Other Language</i>	Select to choose a language other than the ones displayed (see <i>Using the language code list</i> on page 38).

Note

¹ In the table, the default setting is shown in **bold**; other settings are shown in *italics*.

• Some settings, such as **TV Screen**, **Audio Language** and **Subtitle Language** may be overridden by the DVD disc. Often these settings can also be made from the DVD disc menu.

• The **Component Out** setting only needs to be set if you have connected this player to your TV using component video.

Setting	Option	What it means
Subtitle Language	English	If there are English subtitles on the disc they are displayed.
	<i>Languages as displayed</i>	The subtitle language selected on the disc is displayed.
	<i>Other Language</i>	Select to choose a language other than the ones displayed (see <i>Using the language code list</i> on page 38).
DVD Menu Language	w/Subtitle Lang.	DVD disc menus are displayed in the same language as your selected subtitle language, if possible.
	<i>Languages as displayed</i>	DVD menus are displayed in the selected language, if possible.
	<i>Other Language</i>	Select to choose a language other than the ones displayed (see <i>Using the language code list</i> on page 38).
Subtitle Display	On	Subtitles are displayed in your selected subtitle language.
	Off	Subtitles are always off by default when you play a DVD disc.

Display settings

Setting	Option	What it means
OSD Language	English	On-screen displays of the player are in English.
	<i>Languages as displayed</i>	On-screen displays are shown in the language selected.
Angle Indicator	On	A camera icon is displayed on-screen during multi-angle scenes on a DVD disc.
	Off	No multi-angle indication is shown.

Options settings

Setting	Option	What it means
Parental Lock	–	See <i>Parental Lock</i> below.
DivX VOD	Display	See <i>About DivX® VOD content</i> below.

Parental Lock

- Default level: **Off**; Default password: *none*;
Default Country/Area code: **us (2119)**

To give you some control over what your children watch on your DVD player, some DVD-Video discs feature a Parental Lock level. If your player is set to a lower level than the disc, the disc won't play.

Some discs also support the Country/Area Code feature. The player does not play certain scenes on these discs, depending on the Country/Area Code you set.

Registering a new password

Register a password to change the Parental Lock level or enter a Country/Area code.¹

Note

- 1 • Not all discs use Parental Lock, and will play without requiring the password first.
 - If you forget your password, you'll need to reset the player to register a new password. (see *Resetting the system* on page 38).

1 Select 'Password'.

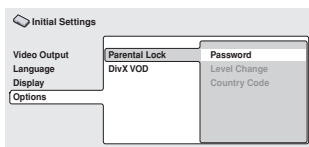

2 Use the number buttons to input a 4-digit password then press ENTER.

Changing your password

To change your password, confirm your existing password then enter a new one.

1 Select 'Password Change'.

2 Input your existing password, then press ENTER.

3 Enter a new password and press ENTER.

Setting/changing the Parental Lock

1 Select 'Level Change'.

2 Use number buttons to enter your password, then press ENTER.

3 Select a new level and press ENTER.

- Press ← (cursor left) repeatedly to lock more levels (more discs will require the password); press → (cursor right) to unlock levels. You can't lock level 1.

Setting/changing the Country/Area code

You can find the *Country/Area code list* on page 39.

1 Select 'Country Code'.

2 Input your password, then press ENTER.

3 Select a Country/Area code then press ENTER.

There are two ways you can do this:

- Select by code letter: Use ↑/↓ (cursor up/down) to change the Country/Area code.
- Select by code number: Press → (cursor right) then use the number buttons to enter the 4-digit Country/Area code.

The new Country/Area code takes effect after ejecting the disc once.

About DivX® VOD content

In order to play DivX VOD (video on demand) content on this player, you first need to register the player with your DivX VOD content provider. You do this by generating a DivX VOD registration code, which you submit to your provider.¹



Important

- DivX VOD content is protected by a DRM (Digital Rights Management) system. This restricts playback of content to specific, registered devices.
- If you load a disc that contains DivX VOD content not authorized for your player, the message **Authorization Error** is displayed and the content will not play.

Displaying your DivX VOD registration code

1 Press HOME MENU and select 'Initial Settings'.

2 Select 'Options', then 'DivX VOD'.

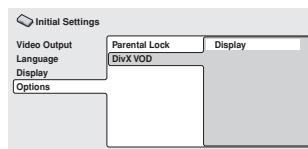

Note

¹ Resetting the player (as described in *Resetting the system* on page 38) will not cause you to lose your registration code.

3 Select 'Display'.

Your 8-digit registration code is displayed.

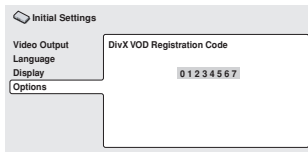

Make a note of the code as you will need it when you register with a DivX VOD provider.

Playing DivX® VOD content

Some DivX VOD content may only be playable a fixed number of times. When you load a disc containing this type of DivX VOD content, the remaining number of plays is shown on-screen and you then have the option of playing the disc (thereby using up one of the remaining plays), or stopping. If you load a disc that contains expired DivX VOD content (for example, content that has zero remaining plays), the message **Rental Expired** is displayed.

If your DivX VOD content allows an unlimited number of plays, then you may load the disc into your player and play the content as often as you like, and no message will be displayed.

Chapter 12

Additional information

Using the System Setup menu

A number of additional settings (listed below) can be accessed by using the System Setup menu. The first setting in each is the default.

1 If necessary, switch into standby.

This is necessary if you want to access the *System Setup menu options in standby* below.

2 Press SYSTEM SETUP (SHIFT+HOME MENU).**3 Use ←/→ (cursor left/right) to choose the setting then press ENTER.**

The current setting is shown for each option as you cycle through the display. See below for a full list and description of each.

4 Use ↑/↓ (cursor up/down) to adjust the setting then press ENTER to confirm.**5 Repeat steps 2 to 4 to make other settings.****System Setup menu options**

These are all the available settings in the setup menu when the system is switched on:¹

Dimmer setting

Sets the front panel display brightness level:

- LIGHT
- DARK

Tape deck beat cut setting

Recording AM broadcasts on cassette tape can result in noisy recordings. If you experience this, change the beat cut mode.

- B.CUT 1
- B.CUT 2

System Setup menu options in standby

Below are all the available settings in the setup menu when in standby:

System demo setting

Switches the automatic demo feature on or off:

- ON – Switches the demo feature on.
- OFF – Switches the demo feature off.

Frequency step setting

Applicable to Singapore, Malaysia, Taiwan, Indonesia and Philippines models only

If you find that you can't tune into stations successfully, the frequency step may not be suitable for your country/region.

- AM 9K – AM 9kHz / FM50kHz
- AM 10K – AM10kHz / FM100kHz

TV system setting

The default setting of this system is **AUTO**, and unless you notice that the picture is distorted when playing some discs, you should leave it set to **AUTO**. If you find picture distortion with some discs, set the TV system to match your country or region's system. However, this may restrict the kinds of disc you can watch.

See the table for the kinds of discs compatible with each setting (**AUTO**, **PAL** and **NTSC**).²

Note

¹ If the tuner is selected, the tuner options also appear (see *Automatically saving station presets* on page 17 and *Manual tuner features* on page 25). Note that the beat cut setting only appears during AM reception.

² Most models of the newly developed countdown PAL TV system detect 50 Hz (PAL)/60 Hz (NTSC) and automatically switch vertical amplitude, resulting in a display without vertical shrinkage. However, in some cases, the image may appear without color. If your PAL TV does not have a V-Hold control, you may not be able to watch NTSC discs because of picture roll. If the TV has a V-Hold control, adjust it until the picture stops rolling. On some TVs, the picture may shrink vertically, leaving black bands at the top and bottom of the screen.

- After selecting **TV SYS** in step 3 above, press **ENTER** to change the TV system.

The TV system as follows:

- **AUTO** → **NTSC**
- **NTSC** → **PAL**
- **PAL** → **AUTO**

The system automatically switches on and you'll see the new TV system setting in the display after seeing **Welcome**.¹

Disc Type	Format	Player setting		
		NTSC	PAL	AUTO
DVD/Super VCD/ Video CD/DivX Video	NTSC	NTSC	PAL	NTSC
	PAL	NTSC	PAL	PAL
CD/MP3/WMA/ JPEG/no disc	—	NTSC	PAL	NTSC or PAL

Interlace setting

Use this setting if you lose the picture because your TV is incompatible with progressive scan video. See *Important in About progressive scan video* on page 8 for more on this setting.



- After pressing **ENTER** in step 3 in *Using the System Setup menu* above, this setting is enabled and the system automatically switches on.

Disc / content format playback compatibility

This player is compatible with a wide range of disc types (media) and formats. Playable discs will generally feature one of the following logos on the disc and/or disc packaging. Note however that some disc types, such as recordable CD and DVD, may be in an unplayable format.

See the *Disc compatibility table* below for more information.



-  is a trademark of Fuji Photo Film Co. Ltd.
-  is a trademark of DVD Format/Logo Licensing Corporation
- Also compatible with KODAK Picture CD

This player supports the IEC's Super VCD standard for superior picture quality, dual soundtracks, and widescreen support.



About DualDisc playback

A DualDisc is a new two-sided disc, one side of which contains DVD content (video, audio, etc.) while the other side contains non-DVD content such as digital audio material. The non-DVD, audio side of the disc is not compliant with the CD Audio specification and therefore may not play. The DVD side of a DualDisc plays in this product (excluding DVD-Audio content). For more detailed information on the DualDisc specification, please refer to the disc manufacturer or disc retailer.

Note

¹ You have to switch the player into standby (press **STANDBY/ON**) before each change.

Disc compatibility table

Media	Compatible formats
CD-R/RW	<ul style="list-style-type: none"> • CD-Audio, Video CD/Super VCD, ISO 9660 CD-ROM* * <i>ISO 9660 Level 1 or 2 compliant. CD physical format: Mode1, Mode2 XA Form1. Romeo and Joliet file systems are both compatible.</i> • Multi-session playback: No • Unfinalized disc playback: No
DVD-R/RW	<ul style="list-style-type: none"> • DVD-Video, Video Recording (VR)* * <i>Edit points may not play exactly as edited; screen may go momentarily blank at edited points.</i> • Unfinalized playback: No • WMA/MP3/JPEG file playback on DVD-R/RW: No
PC-created disc	<ul style="list-style-type: none"> • Discs recorded using a PC may not be playable due to the setting of the software used to create the disc. In these instances, check the DVD-R/RW or CD-R/RW software manual or disc boxes for more on compatibility. • Discs recorded in packet write mode (UDF format) are not compatible.
Compressed audio	<ul style="list-style-type: none"> • MPEG-1 Audio Layer 3 (MP3), Windows Media Audio (WMA) • Sampling rates: 32, 44.1 or 48kHz • Bit-rates: Any (128Kbps or higher recommended) • VBR (variable bit rate) MP3 playback: No • VBR WMA playback: No • WMA lossless encoding: No • DRM (Digital Rights Management) compatible: Yes (DRM-protected audio files will <i>not</i> play in this player). • File extensions: .mp3, .wma (these must be used for the player to recognize MP3 and WMA files) • File structure (may differ): Up to 299 folders on a disc; up to 648 folders and files (combined) within each folder

Media	Compatible formats
JPEG file	<ul style="list-style-type: none"> • Baseline JPEG and EXIF 2.2* still image files up to a resolution of 3072 x 2048. *<i>File format for digital still cameras</i> • File extensions: .jpg (must be used for the player to recognize JPEG files) • File structure (may differ): Up to 299 folders on a disc; up to 648 folders and files (combined) within each folder

DVD Video regions

All DVD Video discs carry a region mark that indicates which region(s) of the world the disc is compatible with. Your DVD system also has a region mark (on the rear panel). Discs from incompatible regions will not play in this player. Discs marked **ALL** play in any player.

About DivX

DivX is a compressed digital video format created by the DivX[®] video codec from DivXNetworks, Inc. This player can play DivX video files burned on CD-R/RW/ROM discs. Keeping the same terminology as DVD-Video, individual DivX video files are called "Titles." When naming files/titles on a CD-R/RW disc prior to burning, keep in mind that by default they will be played in alphabetical order.

DivX video compatibility

- Official DivX[®] Certified product.
- Plays DivX[®] 5, DivX[®] 4, DivX[®] 3, and DivX[®] VOD video content (in compliance with DivX[®] Certified technical requirements).
- File extensions: .avi and .divx (these must be used for the player to recognize DivX video files). *Note that all files with the .avi extension are recognized as MPEG4, but not all of these are necessarily DivX video files and therefore may not be playable on this player.*

Displaying DivX subtitle files

The font sets listed below are available for DivX external subtitle files. You can see the proper font set on-screen by setting the **Subtitle Language** (in *Language settings* on page 29)

to match the subtitle file.¹

This player displays subtitles for the following language groups:

Group 1: Albanian (sq), Basque (eu), Catalan (ca), Danish (da), Dutch (nl), English (en), Faroese (fo), Finnish (fi), French (fr), German (de), Icelandic (is), Irish (ga), Italian (it), Norwegian (no), Portuguese (pt), Rhaeto-Romanic (rm), Scottish (gd), Spanish (es), Swedish (sv)

Group 2: Albanian (sq), Croatian (hr), Czech (cs), Hungarian (hu), Polish (pl), Romanian (ro), Slovak (sk), Slovenian (sl)

Group 3: Bulgarian (bg), Byelorussian (be), Macedonian (mk), Russian (ru), Serbian (sr), Ukrainian (uk)

Group 4: Hebrew (iw), Yiddish (ji)

Group 5: Turkish (tr)

DivX, DivX Certified, and associated logos are trademarks of DivXNetworks, Inc. and are used under license.

About WMA



The Windows Media[®] logo printed on the box indicates that this player can playback Windows Media Audio content.

WMA is an acronym for Windows Media Audio and refers to an audio compression technology developed by Microsoft Corporation. WMA content can be encoded by using Windows Media[®] Player version 7, 7.1, Windows Media[®] Player for Windows[®] XP, or Windows Media[®] Player 9 Series.

Note

¹ • For external subtitle files the following subtitle format filename extensions are supported (please note that these files are not shown within the disc navigation menu): .srt, .sub, .ssa, .smi

- Some external subtitle files may be displayed incorrectly or not at all.
- The filename of the movie file has to be repeated at the beginning of the filename for the external subtitle file.
- The number of external subtitle files which can be switched for the same movie file is limited to a maximum of 10.

Microsoft, Windows Media, and the Windows logo are trademarks, or registered trademarks of Microsoft Corporation in the United States and/or other countries.

Taking care of discs

Handling discs

Hold the disc by its edges when handling so as not to leave fingerprints, dirt or scratches on either side of the disc. Damaged or dirty discs can affect playback performance.

If a disc becomes marked with fingerprints, dust, etc., clean using a soft, dry cloth.



Wipe lightly from the center of the disc using straight strokes. Don't wipe the disc surface with circular strokes.

If necessary, use a cloth soaked in alcohol, or a commercially available CD/DVD cleaning kit to clean a disc more thoroughly. Never use benzene, thinner or other cleaning agents such as those designed for cleaning vinyl records.

Storing discs

Avoid leaving discs in excessively cold, humid, or hot environments (including under direct sunlight). Don't glue paper or put stickers onto the disc, or use a pencil, ball-point pen or other sharp-tipped writing instrument. These could all damage the disc.

Discs to avoid

Discs spin at high speed inside the player. If a disc is cracked, chipped, warped, or otherwise damaged, don't risk using it in your player—you could end up damaging the unit.

This unit is designed for use with conventional, fully circular discs only. Pioneer disclaims all liability arising in connection with the use of shaped discs.

Using cassette tapes

The tape of a cassette is quite easily damaged and loose tape can jam in the tape deck mechanism. If the tape has become unwound, use a pen or pencil to wind it back on to the spool.

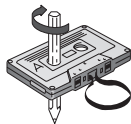

When not using cassettes, always store in the case. Store cassettes away from magnetic fields, excessive heat, humidity, dust or oil.

Before recording on a tape, wind the tape on past the leader tape (about the first 3 or 4 seconds of each side).

Tapes you should avoid

Since tapes longer than 90 minutes are so thin, they are more susceptible to jamming in the tape deck mechanism and other trouble such as irregular winding. Avoid using cassette tapes longer than 90 minutes.

Protecting your recordings

You can protect an important recording against accidental erasure by breaking the erase-protect tab(s) with a small screwdriver.

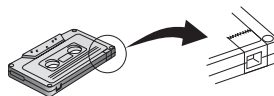

If you want to re-record on an erase-protected cassette, cover the space left by the broken tab with self-adhesive tape.

**Installation and maintenance****Hints on installation**

We want you to enjoy using this system for years to come, so please bear in mind the following points when choosing a location:

Do...

- ✓ Use in a well-ventilated room.
- ✓ Place on a solid, flat, level surface, such as a table, shelf or stereo rack.

Don't...

- ✗ Use in a place exposed to high temperatures or humidity, including near radiators and other heat-generating appliances.
- ✗ Place on a window sill or other place where the system will be exposed to direct sunlight.
- ✗ Use in an excessively dusty or damp environment.
- ✗ Place directly on top of an amplifier, or other component in your stereo system that becomes hot in use.
- ✗ Use near a television or monitor as you may experience interference—especially if the television uses an indoor antenna.
- ✗ Use in a kitchen or other room where the system may be exposed to smoke or steam.
- ✗ Use on a thick rug or carpet, or cover with cloth—this may prevent proper cooling of the system unit.
- ✗ Use on an unstable surface, or one that is not large enough to support all four of the system unit's feet.

Cleaning the pickup lens

The DVD player's lens should not become dirty in normal use, but if for some reason it should malfunction due to dust or dirt, consult your nearest Pioneer authorized service center. Although lens cleaners are commercially available, we do not recommend using them since some may damage the lens.

Problems with condensation

Condensation may form inside the player if it is brought into a warm room from outside, or if the temperature of the room rises quickly. Although this won't damage the player, it may temporarily impair performance. You should leave it to adjust to the warmer temperature for about an hour before switching on.

Moving the system unit

If you need to move the main unit, first remove a disc if there's one in the player, then press **STANDBY/ON** on the front panel to turn the system off. Wait for **GOOD BYE** to disappear from the display, then unplug the power cord.¹ Never lift or move the unit during playback—discs rotate at high speeds and may damage.

Resetting the system

Use this procedure to reset all system settings to the factory default. Use the front panel controls to do this.

- **With the system switched on, press **STANDBY/ON** while holding down the **(stop) button**.**

The system switches to standby, and the next time you switch on, all the system's settings will be reset.

Screen sizes and disc formats

DVD-Video discs come in different screen aspects, ranging from TV programs, which are generally 4:3, to CinemaScope widescreen movies², with an aspect ratio of up to about 7:3. Televisions also come in different aspect ratios; 'standard' 4:3 and widescreen 16:9.³



Set to 4:3 (Letter Box), widescreen discs are shown with black bars top and bottom.



Set to **4:3 (Pan&Scan)**, widescreen discs are shown with the left and right sides cropped. Although the picture looks larger, you don't actually see the whole picture.

Using the language code list

Some of the language options (see *Language settings* on page 29) allow you to set your preferred language from any of the 136 languages listed in the *Language code list*.

- 1 **Select 'Other Language'.**
- 2 **Use **←/→** (cursor left/right) to select either a code letter or a code number.**
- 3 **Use **↑/↓** (cursor up/down) to select a code letter or a code number.**

See the *Language code list* (next page) for a complete list of languages and codes.

Note

- 1 Unplugging the unit before **GOOD BYE** disappears from the display may cause the system to return to the factory settings.
- 2 Many widescreen discs override the system's settings so that the disc is shown in letterbox format regardless of the setting.
- 3 Using the **16:9 (Wide)** setting with a standard 4:3 TV, or one of the **4:3** settings with a widescreen TV, will result in distortion.
 - When you watch discs recorded in 4:3 format, you can use the TV controls to select how the picture is presented. Your TV may offer various zoom and stretch options; see the instructions that came with your TV for details.
 - Some movie aspect ratios are wider than 16:9, so even with a widescreen TV, these discs will still play in a 'letterbox' style.

Language code list

Language (Language code letter), **Language code**

Japanese (ja), 1001	Estonian (et), 0520	Lingala (ln), 1214	Slovak (sk), 1911
English (en), 0514	Basque (eu), 0521	Laothian (lo), 1215	Slovenian (sl), 1912
French (fr), 0618	Persian (fa), 0601	Lithuanian (lt), 1220	Samoan (sm), 1913
German (de), 0405	Finnish (fi), 0609	Latvian (lv), 1222	Shona (sn), 1914
Italian (it), 0920	Fiji (fj), 0610	Malagasy (mg), 1307	Somali (so), 1915
Spanish (es), 0519	Faroese (fo), 0615	Maori (mi), 1309	Albanian (sq), 1917
Dutch (nl), 1412	Frisian (fy), 0625	Macedonian (mk), 1311	Serbian (sr), 1918
Russian (ru), 1821	Irish (ga), 0701	Malayalam (ml), 1312	Siswati (ss), 1919
Chinese (zh), 2608	Scots-Gaelic (gd), 0704	Mongolian (mn), 1314	Sesotho (st), 1920
Korean (ko), 1115	Galician (gl), 0712	Moldavian (mo), 1315	Sundanese (su), 1921
Greek (el), 0512	Guarani (gn), 0714	Marathi (mr), 1318	Swedish (sv), 1922
Afar (aa), 0101	Gujarati (gu), 0721	Malay (ms), 1319	Swahili (sw), 1923
Abkhazian (ab), 0102	Hausa (ha), 0801	Maltese (mt), 1320	Tamil (ta), 2001
Afrikaans (af), 0106	Hindi (hi), 0809	Burmese (my), 1325	Telugu (te), 2005
Amharic (am), 0113	Croatian (hr), 0818	Nauru (na), 1401	Tajik (tg), 2007
Arabic (ar), 0118	Hungarian (hu), 0821	Nepali (ne), 1405	Thai (th), 2008
Assamese (as), 0119	Armenian (hy), 0825	Norwegian (no), 1415	Tigrinya (ti), 2009
Aymara (ay), 0125	Interlingua (ia), 0901	Occitan (oc), 1503	Turkmen (tk), 2011
Azerbaijani (az), 0126	Interlingue (ie), 0905	Oromo (om), 1513	Tagalog (tl), 2012
Bashkir (ba), 0201	Inupiak (ik), 0911	Oriya (or), 1518	Setswana (tn), 2014
Byelorussian (be), 0205	Indonesian (in), 0914	Panjabi (pa), 1601	Tonga (to), 2015
Bulgarian (bg), 0207	Icelandic (is), 0919	Polish (pl), 1612	Turkish (tr), 2018
Bihari (bh), 0208	Hebrew (iw), 0923	Pashto, Pushto (ps), 1619	Tsonga (ts), 2019
Bislama (bi), 0209	Yiddish (ji), 1009	Portuguese (pt), 1620	Tatar (tt), 2020
Bengali (bn), 0214	Javanese (jw), 1023	Quechua (qu), 1721	Twi (tw), 2023
Tibetan (bo), 0215	Georgian (ka), 1101	Rhaeto-Romanic (rm), 1813	Ukrainian (uk), 2111
Breton (br), 0218	Kazakh (kk), 1111	Kirundi (rn), 1814	Urdu (ur), 2118
Catalan (ca), 0301	Greenlandic (kl), 1112	Romanian (ro), 1815	Uzbek (uz), 2126
Corsican (co), 0315	Cambodian (km), 1113	Kinyarwanda (rw), 1823	Vietnamese (vi), 2209
Czech (cs), 0319	Kannada (kn), 1114	Sanskrit (sa), 1901	Volapük (vo), 2215
Welsh (cy), 0325	Kashmiri (ks), 1119	Sindhi (sd), 1904	Wolof (wo), 2315
Danish (da), 0401	Kurdish (ku), 1121	Sangho (sg), 1907	Xhosa (xh), 2408
Bhutani (dz), 0426	Kirghiz (ky), 1125	Serbo-Croatian (sh), 1908	Yoruba (yo), 2515
Esperanto (eo), 0515	Latin (la), 1201	Sinhalese (si), 1909	Zulu (zu), 2621

Country/Area code list

Country/Area, Country/Area code, **Country/Area code letter**

Argentina, 0118, ar	Hong Kong, 0811, hk	Philippines, 1608, ph
Australia, 0121, au	India, 0914, in	Portugal, 1620, pt
Austria, 0120, at	Indonesia, 0904, id	Russian Federation, 1821, ru
Belgium, 0205, be	Italy, 0920, it	Singapore, 1907, sg
Brazil, 0218, br	Japan, 1016, jp	Spain, 0519, es
Canada, 0301, ca	Korea, Republic of, 1118, kr	Switzerland, 0308, ch
Chile, 0312, cl	Malaysia, 1325, my	Sweden, 1905, se
China, 0314, cn	Mexico, 1324, mx	Taiwan, 2023, tw
Denmark, 0411, dk	Netherlands, 1412, nl	Thailand, 2008, th
Finland, 0609, fi	New Zealand, 1426, nz	United Kingdom, 0702, gb
France, 0618, fr	Norway, 1415, no	United States of America, 2119, us
Germany, 0405, de	Pakistan, 1611, pk	

Troubleshooting

Incorrect operations are often mistaken for trouble and malfunctions. If you think that there is something wrong with this component, check the points below. Sometimes the trouble may lie in another component. Investigate the other components and electrical appliances being used. If the trouble cannot be rectified even after exercising the checks listed below, ask your nearest Pioneer authorized service center or your dealer to carry out repair work.

- If the unit does not operate normally due to external effects such as static electricity disconnect the power plug from the outlet and insert again to return to normal operating conditions.

General

Problem	Remedy
The power does not turn on.	<ul style="list-style-type: none"> • Connect the power plug to the wall outlet. • Disconnect the power plug from the outlet, and insert again. • Make sure the voltage selector (page 3) is set correctly for your region.
The power suddenly switches off automatically and won't switch back on for a minute or so. Also, the playback / volume control's blue backlight is blinking.	<ul style="list-style-type: none"> • If the speaker cables aren't connected properly, the system has a safety feature that shuts the power off automatically. Check the speaker wires to make sure they're connected properly. If there appears to be nothing wrong, try switching the power back on after the blue backlight has been blinking for a minute or so. • If you can't seem to switch the power back on after the blue backlight has been blinking for over a minute, the unit may be malfunctioning. Take it to your nearest Pioneer authorized service center or your dealer to carry out repair work.
No sound is output when a function is selected.	<ul style="list-style-type: none"> • If you're using the LINE input, make sure the component is connected correctly (see <i>Connecting auxiliary components</i> on page 9). • Press MUTE on the remote control to turn muting off. • Adjust the volume.
No image is output when watching discs.	<ul style="list-style-type: none"> • Make sure the TV is connected correctly (see <i>Connecting to your TV</i> on page 8).
Can't operate the remote control.	<ul style="list-style-type: none"> • Replace the batteries (see <i>Loading the batteries</i> on page 5). • Operate within 7 m, 30° of the remote sensor on the front panel (see <i>Range of the remote control unit</i> on page 13). • Remove the obstacle or operate from another position. • Avoid exposing the remote sensor on the front panel to direct light.
The microphone can't be heard.	<ul style="list-style-type: none"> • You are only using one microphone and it's plugged into the MIC (SUB) jack. The MIC (SUB) jack can only be used if there is also a microphone plugged into the MIC (MAIN) jack. • Adjust the MIC VOL.
Feedback noise when mic is switched on.	<ul style="list-style-type: none"> • The mic is pointing toward the speakers. Keep the mic pointed away from the speakers. • The microphone level is set too high. Turn down the mic control level.
SND. DEMO shows in the display and the unit can't be controlled.	<ul style="list-style-type: none"> • Press and hold ■ (stop) on the front panel for about five seconds. The disc tray ejects automatically to indicate the Sound Demo mode is disabled.
TRAYLOCK shows in the display and the tray can't be ejected.	<ul style="list-style-type: none"> • Press and hold ▲ OPEN/CLOSE on the front panel for about eight seconds (until LOCK OFF appears in the display). Then the tray can be opened/closed using ▲ OPEN/CLOSE.

DVD/CD/Video CD player

Problem	Remedy
The disc is ejected automatically after loading.	<ul style="list-style-type: none"> • Clean the disc. • Align the disc properly in the disc guide. • If the region number on a DVD-video disc does not match the number on the player, the disc cannot be used (see <i>DVD Video regions</i> on page 35). • Allow time for any condensation inside the player to evaporate. Avoid using the player near an air-conditioning unit.
Playback is not possible.	<ul style="list-style-type: none"> • Disc may be loaded upside down. Reload the disc with the label side face up.
Picture playback stops and the operation buttons cannot be used.	<ul style="list-style-type: none"> • Press ■, then start playback again (▶). • Switch the power off once, then on again using the front panel STANDBY/ON button.
Settings are canceled.	<ul style="list-style-type: none"> • When the power is cut due to power failure or by unplugging the power cord for several days, settings will be canceled.
No picture/No color.	<ul style="list-style-type: none"> • Check that connections are correct and that plugs are inserted fully. • Check the instruction manual of the TV/monitor to make sure the TV/monitor settings are incorrect.
Screen is stretched or aspect does not change.	<ul style="list-style-type: none"> • The TV Screen setting is incorrect. Set the TV Screen option to match the TV/monitor you're using (see <i>Video Output settings</i> on page 29).
When recorded on a VCR or passed through an AV selector, there is disturbance in the playback picture.	<ul style="list-style-type: none"> • Due to the player's copy protection circuits, connection of this device through a VCR or an AV selector may prevent recording or cause picture problems. This is not a malfunction.
Picture disturbance during playback or dark.	<ul style="list-style-type: none"> • This player is compatible with Macro-Vision System copy guard. Some discs include a copy prevention signal, and when this type of disc is played back, stripes etc., may appear on some sections of the picture depending on the TV. This is not a malfunction. • Discs respond differently to particular player functions. This may result in the screen becoming black for a brief instant or shaking slightly when the function is executed. These problems are largely due to differences between discs and disc content and are not malfunctions of this player.
Noticeable difference in DVD and CD volume.	<ul style="list-style-type: none"> • DVDs and CDs use different recording methods. This is not a malfunction.

WMA/MP3/JPEG discs

Problem	Remedy
CD-ROM disc is not recognized by the system.	<ul style="list-style-type: none"> • Make sure that the CD-ROM was recorded using the ISO 9660 disc format. See <i>Disc / content format playback compatibility</i> on page 34 for other disc compatibility information.
Files don't show up in the Disc Navigator/Photo Browser.	<ul style="list-style-type: none"> • The files on the disc must be named with the correct file extension: .mp3 for MP3 files; .wma for WMA files; .jpg for JPEG files (upper or lower-case is OK). See <i>Disc / content format playback compatibility</i> on page 34 for other disc compatibility information.
Can't play WMA files.	<ul style="list-style-type: none"> • The files were recorded using DRM (digital rights management). This is not a malfunction.

Tuner

Problem	Remedy
Considerable noise in radio broadcasts.	<ul style="list-style-type: none"> • Connect the AM antenna (see <i>Connecting the radio antennas</i> on page 7) and adjust the direction and position for best reception. You may also connect an additional internal or external AM antenna (see <i>Connecting external antennas</i> on page 7). • Fully extend the FM wire antenna, position for best reception, and secure to a wall. You may also connect an outdoor FM antenna (see <i>Connecting external antennas</i> on page 7). • <i>Applicable to Singapore, Malaysia, Taiwan, Indonesia and Philippines models only</i> – The tuning interval is incorrect for your country or region. Try switching the tuning interval (see <i>Frequency step setting</i> on page 33).
Auto tuning does not pick up some stations.	<ul style="list-style-type: none"> • The radio signal is weak. Auto tuning will only detect radio stations with a good signal. For more sensitive tuning, connect an outdoor antenna.
Sound is mono only.	<ul style="list-style-type: none"> • Check that the tuner is not set to FM mono (see <i>Improving FM stereo sound</i> on page 25).

Tape deck

Problem	Remedy
Cannot record.	<ul style="list-style-type: none"> • Check that the cassette still has its erase-protect tabs intact, or that they are covered with self-adhesive tape (<i>Using cassette tapes</i> on page 37).
Sound is muffled or previous recording is still audible underneath the new one.	<ul style="list-style-type: none"> • The tape heads may be dirty. Clean the tape heads using a head-cleaning cassette or cleaning kit. • Check that you're using a Type I (normal) tape. Do not use Type II (high/CrO₂) or Type IV (metal) tapes.
Music search does not work.	<ul style="list-style-type: none"> • The spaces between songs may be too short for music search to work (see <i>Playing cassette tapes</i> on page 16).

Error Messages

Message	Description
SND. DEMO	• The sound demo is on. See <i>General</i> in <i>Troubleshooting</i> on page 40.
TRAYLOCK	• The tray lock is on. See <i>General</i> in <i>Troubleshooting</i> on page 40.
EEP ERR	• Contact your Pioneer authorized service center or your dealer for servicing.

Specifications

• Amplifier section

Front 100 W per channel
(1 kHz, 10 % T.H.D., 6 Ω)

• Disc section

Digital audio characteristics DVD fs: 96 kHz, 24-bit
Type DVD system, Video CD/Super VCD system
and Compact Disc digital audio system
Frequency response 4 Hz to 44 kHz
S/N ratio 107 dB
Dynamic range 94 dB
Total harmonic distortion 0.007 %
Wow and Flutter Limit of measurement
(±0.001 % W.PEAK) or less (JEITA)

• Cassette deck section

Systems 4 track, 2-channel stereo
Heads Recording/playback head x 1
Erasing head x 1
Motor DC servo motor x 1
Tape types Type I (Normal)

• FM tuner section

Frequency range 87.5 MHz to 108 MHz
Antenna 75 Ω, unbalanced

• AM tuner section

Frequency range
With 9kHz step 531 kHz to 1,602 kHz
With 10kHz step (Singapore, Malaysia,
Taiwan, Indonesia and Philippines
models only) 530 kHz to 1,700 kHz
Antenna Loop antenna

• Miscellaneous

Power requirements
Singapore, Malaysia, Taiwan, Indonesia and
Philippines models AC 110-120/220-230/
240 V (switchable), 50/60 Hz
All other models AC 110-127/220-230/
240 V (switchable), 50/60 Hz
Power consumption 124 W
(0.32 W in standby)
Dimensions (Stereo DVD Cassette
Deck Receiver) 360(W) x 145 (H) x 364 (D) mm
Weight (Stereo DVD Cassette Deck
Receiver) 6.6 kg

• Accessories (Stereo DVD Cassette Deck Receiver)

Remote control 1
Dry cell batteries (AA/R6) 2
Video cord 1
AM loop antenna 1
FM antenna 1
Power cord
Singapore, Malaysia, Taiwan, Indonesia and
Philippines models 2
All other models 1
These operating instructions

Speaker system

• Front speakers

Enclosure Bass-reflex bookshelf type
(magnetically shielded)
System 16 cm 2-way system
Speakers:
Woofer 16 cm cone type
Tweeter 5.2 cm cone type
Nominal impedance 6 Ω
Frequency range 40 Hz to 20 kHz
Maximum input power 100 W
Dimensions 200 (W) x 350.5 (H) x 251 (D) mm
Weight 3.7 kg

• Accessories (Speaker System)

Non-skid pads 8



Note

- Specifications and design subject to possible modification without notice, due to improvements.

Manufactured under license from Dolby Laboratories. "Dolby" and the double-D symbol are trademarks of Dolby Laboratories.

"DTS" and "DTS 2.0" are trademarks of Digital Theater Systems, Inc.

Published by Pioneer Corporation
Copyright ©2005 Pioneer Corporation
All rights reserved

PIONEER CORPORATION

4-1, Meguro 1-Chome, Meguro-ku, Tokyo 153-8654, Japan

PIONEER ELECTRONICS (USA) INC.

P.O. BOX 1540, Long Beach, California 90810-1540, U.S.A. TEL: (800) 421-1404

PIONEER ELECTRONICS OF CANADA, INC.

300 Allstate Parkway, Markham, Ontario L3R 0P2, Canada TEL: 1-877-283-5901

PIONEER EUROPE NV

Haven 1087, Keetberglaan 1, B-9120 Melsele, Belgium TEL: 03/570.05.11

PIONEER ELECTRONICS ASIACENTRE PTE. LTD.

253 Alexandra Road, #04-01, Singapore 159936 TEL: 65-6472-7555

PIONEER ELECTRONICS AUSTRALIA PTY. LTD.

178-184 Boundary Road, Braeside, Victoria 3195, Australia, TEL: (03) 9586-6300

PIONEER ELECTRONICS DE MEXICO S.A. DE C.V.

Bldv.Manuel Avila Camacho 138 10 piso Col.Lomas de Chapultepec, Mexico,D.F. 11000 TEL: 55-9178-4270

K002_A_En