

User's Guide

KODAK DP900 / DP1100 Digital Projectors

Contents

Safety Instructions	1
Safety Definitions	1
Safety Symbols	1
Safety Terms:	2
Unpacking the Projector	3
Projector Features	4
Front of Projector	4
Rear and Side of Projector	4
Connector Panel	4
Connecting the Projector	5
Connecting to a Laptop Computer	6
Connecting to a Desktop Computer	7
Connecting to a Video Player	9
Starting the Projector	11
Using the Remote Control	14
Using the Keypad	15
Turning Off the Projector	17
For More Information	18

User's Guide

KODAK DP900 / DP1100 Digital Projectors

This guide contains the setup and operating procedures for your KODAK DP900 or DP1100 Digital Projector. For more information on how to connect, operate and maintain your projector, refer to your *Reference Manual*.

Safety Instructions

Please read and follow all safety instructions provided *before* using your new projector. Failure to comply with safety instructions may result in fire, electrical shock, or personal injury and may damage or impair protection provided by equipment. *Please save all safety instructions.*

Safety Definitions

- **Warning:** Statements identify conditions or practices that could result in permanent personal injury.
- **Caution:** Statements identify conditions or practices that could result in damage to your equipment.

Safety Symbols



Attention: For information about use of a feature, please refer to the *Reference Manual*.





Warning: Hot surface. Do not touch.



An arrow pointing to the lamp door on the projector.

Safety Terms:

- **Warning:** Don't look directly into the lens when the projector is turned on.
- **Warning:** Don't block ventilation openings.
 -  **Warning:** To replace the lamp, turn the power off and unplug the power cord. To avoid burns, wait 30 minutes before opening the lamp door. Follow all instructions provided in the *Reference Manual*.
 -  **Warning:** Please use the power cord provided. Connect the power cord to a receptacle with a protective safety (earth) ground terminal.
- **Warning:** Refer all service to qualified service personnel. Servicing your own projector will void the warranty. See "For More Information" on page 18 for the customer service contact information.
- **Caution:** Don't set liquids on the projector. Spilled liquids may damage your projector.
- **Caution:** Don't place the projector on a hot surface or in direct sunlight.
- **Caution:** Do not drop the projector. Transport the projector in a Kodak-approved case.
- **Caution:** For ceiling mount installations, please use the ceiling mount recommended in the *Reference Guide* and follow all instructions provided with it.
- **Caution:** The projector lamp bulb is pressurized and may rupture after more than 1,000 hours use. Always change the bulb as soon as you notice a decrease in the brightness.

Unpacking the Projector

The projector comes with the items shown here. If any items are missing, call your dealer immediately.

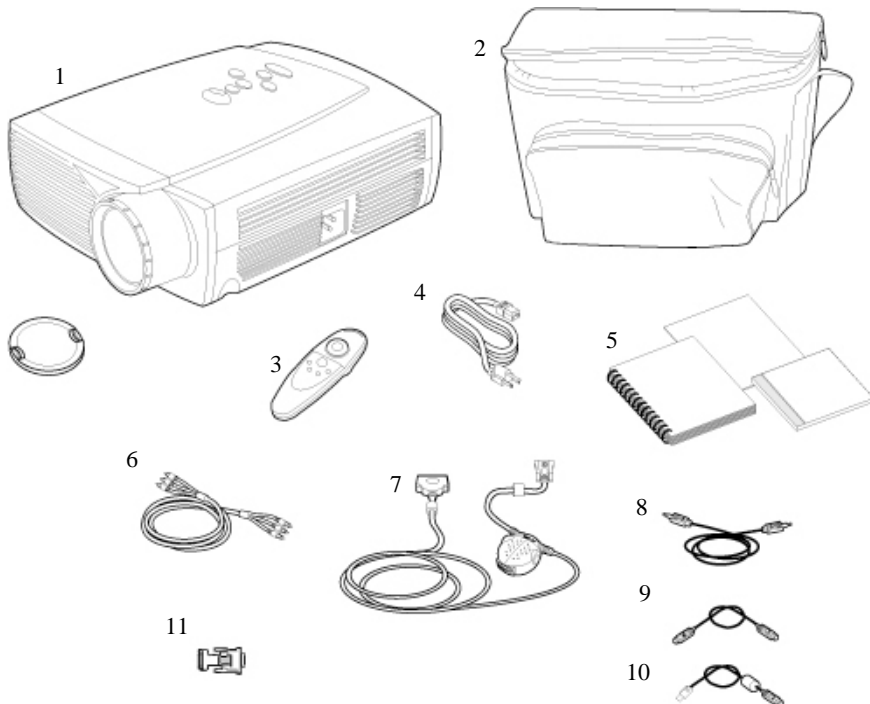

- | | |
|---|--------------------------|
| 1. Digital projector and lens cap | 6. RCA audio/video cable |
| 2. Soft carry case | 7. Cable hub connector |
| 3. Remote control | 8. Audio cable |
| 4. Power cord | 9. PS/2 mouse cable |
| 5. <i>DP900 / DP1100 User's Guide, Reference Manual, and Online User Guide CD</i> | 10. USB mouse cable |
| | 11. MAC adapter |

Note: Optional accessories are not shown.

Projector Features

Front of Projector

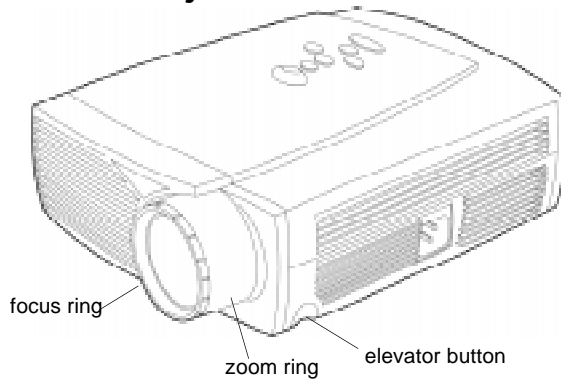

Rear and Side of Projector

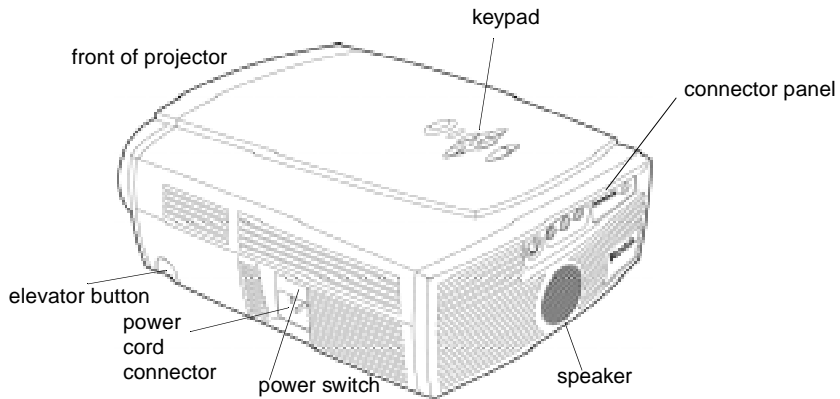

Connector Panel

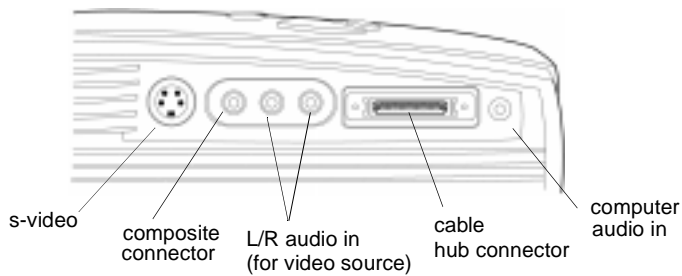

Connecting the Projector

You can connect your projector to a laptop computer, desktop computer, or video player. All connections are made with the aid of icons on the cables. The cables with their icons are shown here.

Caution: Make sure your projector, computer and video player are turned off before you connect them.

Cable hub connector

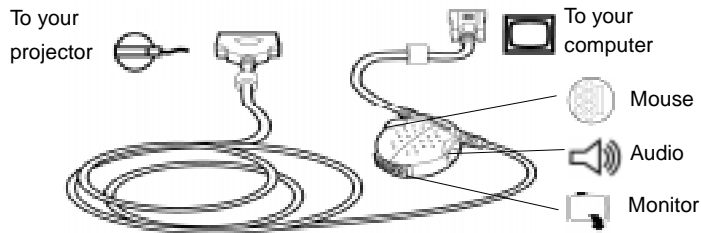

Audio cable



PS/2 mouse cable





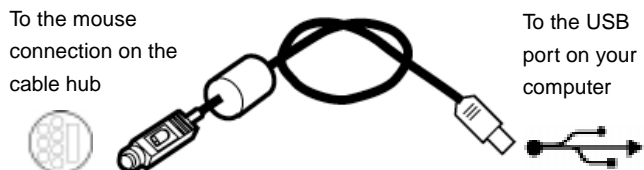

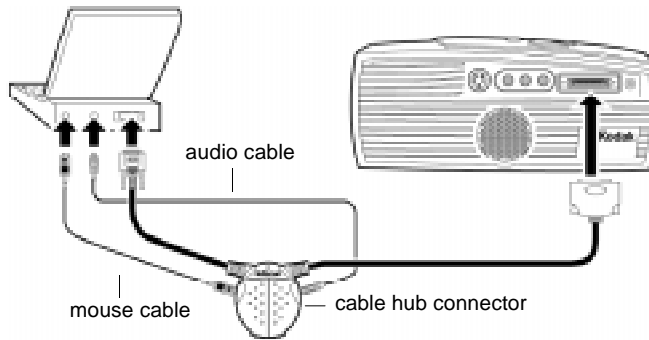

USB mouse cable





Connecting to a Laptop Computer



1. Connect the  end of the cable hub connector to the  connector on the projector's connector panel.
2. Plug the  end of the cable hub connector into the video connector on your laptop.
3. Plug either end of the audio cable into the audio connector on your computer; plug the other end of the audio cable into the  connector on the cable hub.
4. Plug the  end of the PS/2 mouse cable into the mouse connector on your computer; plug the  end of the PS/2 mouse cable into the  connector on the cable hub.





Or if you have a USB connection:

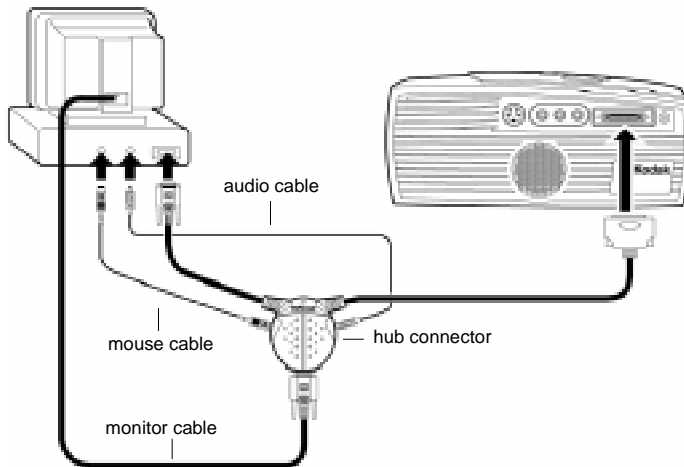

Plug the  end of the USB mouse cable into the USB mouse connector on your computer; plug the  end of the USB mouse cable into the  connector on the cable hub.

To start using your projector, go to “Starting the Projector” on page 11.



Connecting to a Desktop Computer



1. Connect the  end of the cable hub connector to the  connector on the projector's connector panel.
2. Locate the cable that connects your monitor to your computer and unplug it from the computer.
3. Plug your monitor cable into the  connector on the cable hub.
4. Plug the  end of the cable hub into the monitor connector on your computer.
5. Unplug the audio cable, if present, from your computer and plug either end of the audio cable into the audio connector on your computer. Plug the other end of the audio cable into the  connector on the cable hub.

6. Unplug the mouse cable from your computer and plug the  end of the PS/2 mouse cable into the mouse connector on your computer. Then plug the  end of the PS/2 mouse cable into the  connector on the cable hub.

Or if you have a USB connection:

Plug the  end of the USB mouse cable into the USB mouse connector on your computer and plug the  end of the USB mouse cable into the  connector on the cable hub.

To start using your projector, go to “Starting the Projector” on page 11.

Connecting to a Video Player

If your video player uses a round, one-prong composite video connector, you need only the A/V cable that was shipped with the projector. If your video player uses a round, four-prong S-video connector, you need an S-video cable in addition to the A/V cable.

Note: The S-video cable is sold separately. To order the cable, refer to the *Reference Manual*.

Connecting with an AV Cable

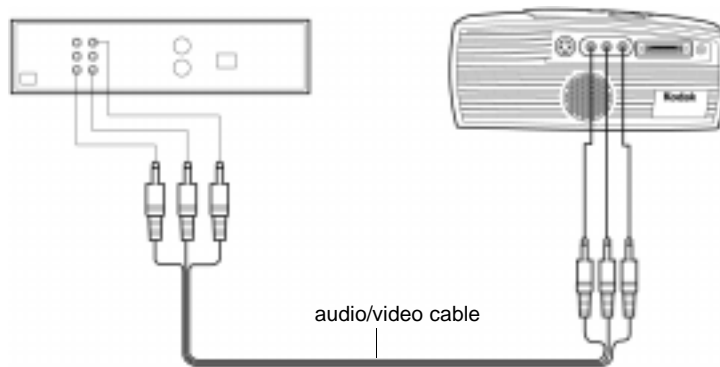

1. Plug the A/V cable's yellow connector into the "video-out" port on your video player. This port may be labeled "To Monitor."
2. Plug the other yellow connector into the composite connector on the back of the projector.
3. Plug the A/V cable's white connector into the left "audio out" port on your video player. Plug the cable's red connector into the right "audio out" port on the video player.
4. Plug the A/V cable's other white and red connectors to the left and right "audio in" ports on the projector.

To start using your projector, go to "Starting the Projector" on page 11.

Connecting with an S-video Cable

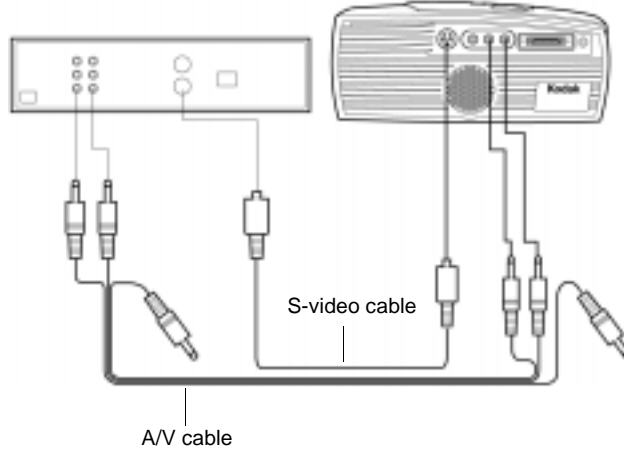

1. Connect the S-video cable to the “s-video out” connector on the video player.
2. Plug the other end of the cable into the “s-video” connector on the projector.
3. Connect the white and red AV cable connectors to the video player and to the projector.

The yellow connectors on the A/V cable are not connected to anything when used with the S-video cable.

To start using your projector, go to “Starting the Projector” on page 11.

Starting the Projector

1. Remove the lens cap.
2. Plug the power cord into the side of the projector, then plug it into your electrical outlet.

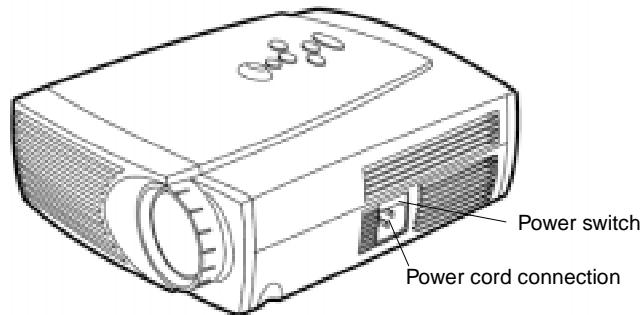

3. Press the "I" side of the power switch to turn on the projector.
The Kodak start-up screen appears and the power LED on top of the projector lights up.

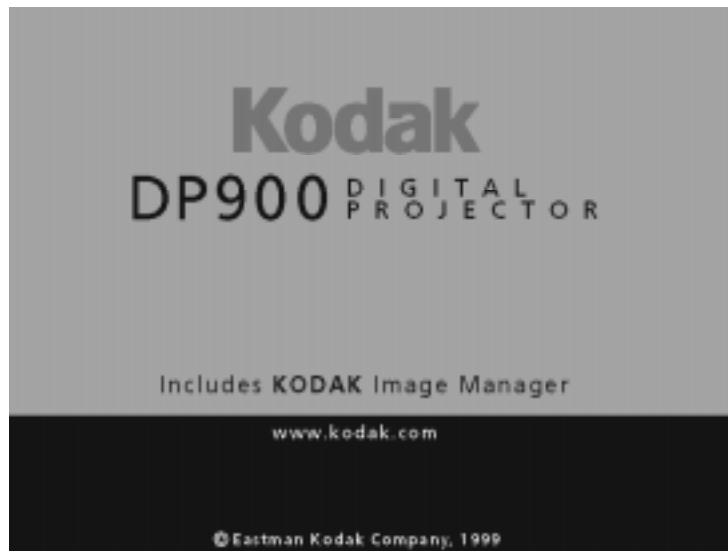

4. Turn on your video source - a video player or a computer.
The video image appears on the projection screen.

5. Position the projector and adjust the zoom setting for the image size you want.

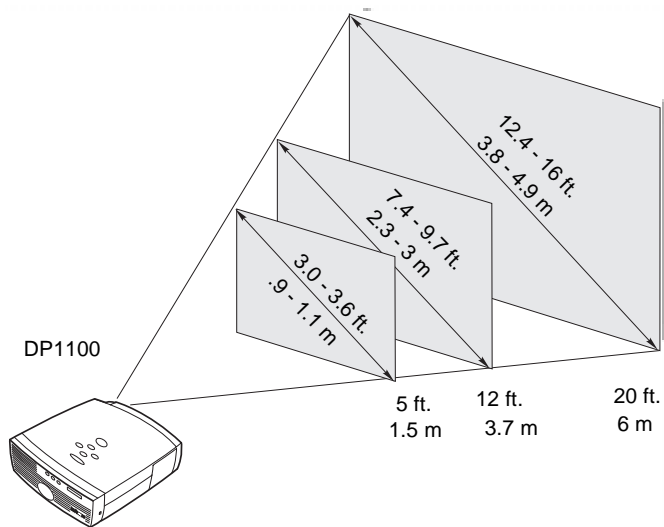
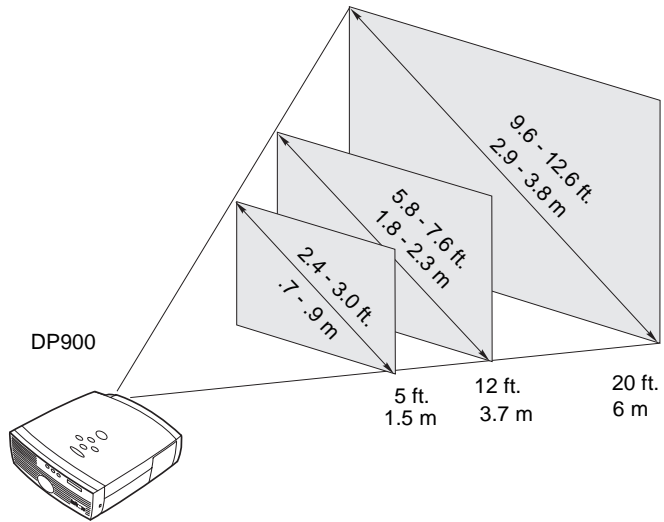

6. Make basic image adjustments. (Refer to the *Reference Manual* for advanced image adjustments.)

- Adjust the zoom ring
- Focus by rotating focus lens.
- Be sure the projector is at a 90-degree angle to the screen.
- Adjust the height of the projector. Press and hold the elevator button. Raise the projector to the height you want, then release the button.

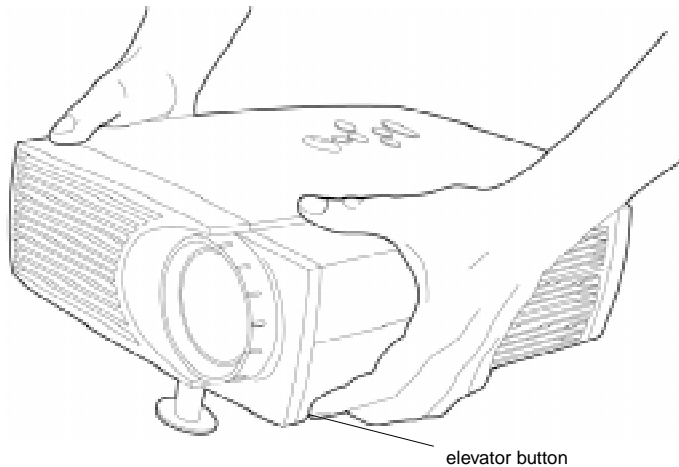

Using the Remote Control

Point the remote control at the projection screen or at the front or rear of the projector. For best results, point the remote directly at the projector. The range for optimum operation is about 40 feet (12 m).

The remote has four function buttons, a disk mouse and two mouse buttons, one on the top of the remote and one on the bottom.

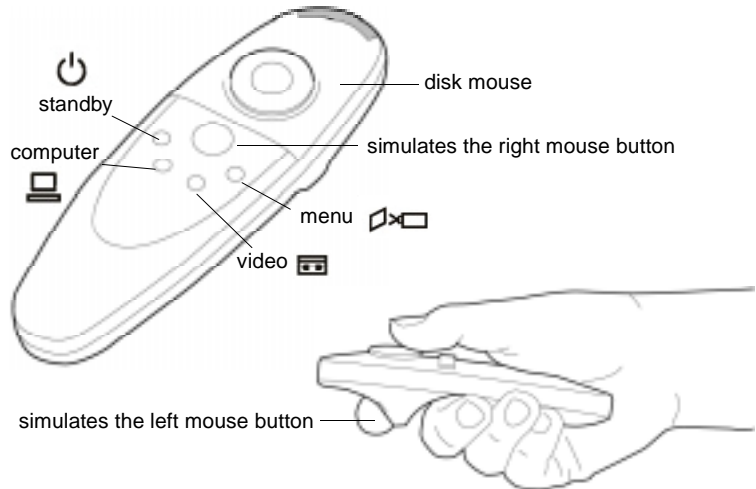

Using the Keypad

The keypad is lit green while the menus are displayed and is lit orange when the projector is on. While the menus are displayed, the volume, source, and standby buttons act as navigation buttons.

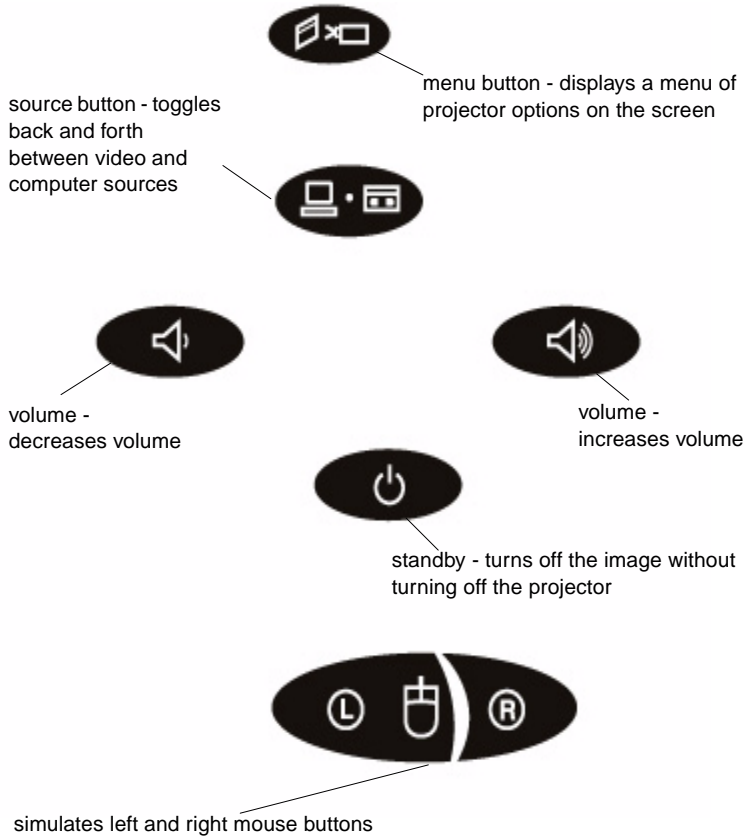



To view the on-screen menus, press the  button on the keypad or remote. The menu bar appears and the volume, source, and standby buttons become navigation buttons. To select a menu, use the keypad or the remote control to move the cursor left and right to highlight the menu you want. The drop-down menu appears.



To change a menu setting, use the up and down navigation buttons on the keypad or the disk mouse on the remote to move the cursor to the desired item. The selected item is highlighted. Then use the left and right mouse buttons at the bottom of the keypad or the mouse buttons on the remote control to adjust a setting. Changes are saved when you close the menus.

To access another menu, use the left and right navigation buttons on the keypad or the disk mouse on the remote control to move left or right to another menu.

Turning Off the Projector

To turn off the projector for a short period of time, press the  button on the keypad or remote control. This blanks the screen for a preset amount of time but keeps the projector running. After the set amount of time elapses again, the lamp turns off. To exit standby mode, press the  button again.

To completely turn off the projector, press the “0” side of the power switch on the side of the projector. If you want to turn the projector back on immediately, allow about a minute for the lamp to cool. The lamp will not light if it is too hot.

Always unplug the projector from the wall outlet before unplugging the cord at the projector.

For More Information

The first place to look for help is in the *Reference Manual*. Be sure to check the guidelines in "Troubleshooting."

Online Services

Contact Kodak via:

World Wide Web	http://www.kodak.com (click on Service and Support)
America Online	(keyword) KODAK
CompuServe	GO KODAK
Kodak Internet List Server	photo-cd@info.kodak.com; or ftp.kodak.com

Faxed Information

Kodak offers automated support by fax:

U.S. and Canada	1-800-295-5531
Europe	44-131-458-6962
U.K.	44-0-131-458-6962

Customer Support

If you have questions concerning the operation of your KODAK projector, you can speak directly to a customer support representative. Have the projector serial number ready, and be at your computer with your projector when you call.

In the U.S. and Canada call toll free, 1-888-375-6325, between the hours of 9:00 a.m. and 8:00 p.m. (Eastern Standard Time) Monday through Friday.

In Europe call

Austria/Osterreich	01 795 67000
Germany/Deutschland	069 9509 6055
Spain/Espana	91 4069130
Belgium/Belgique	02 713 1398
Ireland/Eire	01 402 6815
Sweden/Sverige	08 587 70305
Denmark/Danmark	38 48 7088
Italy/Italia	02 696 33205
Switzerland/Schweiz/ Suisse	01 838 5358
Finland/Soumi	0800 11 8043
Netherlands/Nederland	020 346 9128
UK (National Line)	0870 6061031
France	0141 918578
Norway/Norge	23 16 2041
1 Int. Fax Line	+44 (0) 870 6061032

Eastman Kodak Company
343 State Street
Rochester, New York 14650

Kodak is a trademark of
Eastman Kodak Company.

