

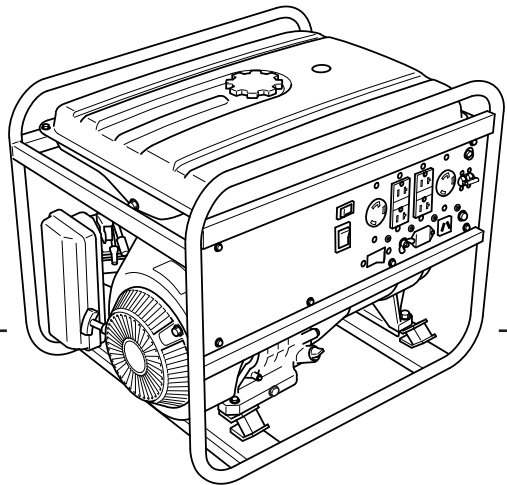

RGX3000
RGX3800
RGX5100
RGX7100
RGX7800





INSTRUCTIONS FOR USE
MANUAL DE INSTRUCCIONES





3ZZ9990434 Original

Robin Generator

(California Proposition 65)

|  DANGER | |
|--|---|
| <p>Using a generator indoors CAN KILL YOU IN MINUTES. Generator exhaust contains carbon monoxide. This is a poison you cannot see or smell.</p> | |
|  |  |
| <p>NEVER use inside a home or garage, EVEN IF doors and windows are open.</p> |  <p>Only use OUTSIDE and far away from windows, doors, and vents.</p> |

|  WARNING:  | |
|---|--|
| <p>The engine exhaust from this product contains chemicals known to the State of California to cause cancer, birth defects or other reproductive harm.</p> | |

FEDERAL EMISSIONS COMPONENT DEFECT WARRANTY

EMISSIONS COMPONENT DEFECT WARRANTY COVERAGE – This emission warranty is applicable in all States, except the state of California.

Fuji Heavy Industries Ltd. and Robin America Inc., Lake Zurich Illinois, (herein "ROBIN AMERICA") warrant(s) to the initial retail purchaser and each subsequent owner, that this Nonroad engine (herein "engine") has been designed, built, and equipped to conform at the time of initial sale to all applicable regulations of the U.S.

Environmental Protection Agency (EPA), and that the engine is free of defects in materials and workmanship which would cause this engine to fail to conform with EPA regulations during its warranty period.

For the components listed under PARTS COVERED, the service dealer authorized by ROBIN AMERICA will, at no cost to you, make the necessary diagnosis, repair, or replacement necessary to ensure that the engine complies with applicable U.S. EPA regulations.

EMISSION COMPONENT DEFECT WARRANTY PERIOD

The warranty period for this engine begins on the date of sale to the initial purchaser and continues for a period of two years.

PARTS COVERED

Listed below are the parts covered by the Emission Components Defect Warranty. Some of the parts listed below may require scheduled maintenance and are warranted up to the first scheduled replacement point for that part.

EXHAUST EMISSIONS

(1) Fuel Metering System

- (i) Carburetor and internal parts (and/or pressure regulator or fuel injection system).
- (ii) Air/fuel ratio feedback and control system, if applicable.
- (iii) Cold start enrichment system, if applicable.
- (iv) Regulator assy (gaseous fuel, if applicable)

(2) Air Induction System

- (i) Intake manifold, if applicable
- (ii) Air filter.

(3) Ignition System

- (i) Spark plugs.
- (ii) Magneto or electronic ignition system.
- (iii) Spark advance/retard system, if applicable.

(4) Exhaust manifold, if applicable

(5) Miscellaneous Items Used in Above Systems

- (i) Electronic controls, if applicable
- (ii) Hoses, belts, connectors, and assemblies.
- (iii) Filter lock assy (gaseous fuel, if applicable)

*EVAPORATIVE EMISSIONS

- (1) Fuel Line
- (2) Fuel Line Fittings
- (3) Clamps

*Fuji is not liable for the warranty on these parts if these parts are installed on the engine by the equipment manufacturer. Please refer to the equipment manufacturer's warranty.

OBTAINING WARRANTY SERVICE

To obtain warranty service, take your engine to the nearest authorized Robin America service dealer. Bring your sales receipts indicating date of purchase for this engine. The service dealer authorized by ROBIN AMERICA will perform the necessary repairs or adjustments within a reasonable amount of time and furnish you with a copy of the repair order. All parts and accessories replaced under this warranty become the property of ROBIN AMERICA.

WHAT IS NOT COVERED

*Conditions resulting from tampering, misuse, improper adjustment (unless they were made by the service dealer authorized by ROBIN AMERICA during a warranty repair), alteration, accident, failure to use the recommended fuel and oil, or not performing required maintenance services.

*The replacement parts used for required maintenance services.

*Consequential damages such as loss of time, inconvenience, loss of use of the engine or equipment, etc.

*Diagnosis and inspection charges that do not result in warranty-eligible service being performed.

*Any non-authorized replacement part, or malfunction of authorized parts due to use of non-authorized parts.

OWNER'S WARRANTY RESPONSIBILITIES

As the engine owner, you are responsible for the performance of the required maintenance listed in your owner's manual. ROBIN AMERICA recommends that you retain all receipts covering maintenance on your engine, but ROBIN AMERICA cannot deny warranty solely for the lack of receipts or for your failure to ensure the performance of all scheduled maintenance.

As the engine owner, you should however be aware that ROBIN AMERICA may deny warranty coverage if your engine or a part has failed due to abuse, neglect, improper maintenance or unapproved modifications.

You are responsible for presenting your engine to the nearest service dealer authorized by ROBIN AMERICA when a problem exists.

If you have any questions regarding your warranty rights and responsibilities, you should contact the Robin America customer service department at 1-800-277-6246 for the information.

THINGS YOU SHOULD KNOW ABOUT THE EMISSION CONTROL SYSTEM WARRANTY MAINTENANCE AND REPAIRS

You are responsible for the proper maintenance of the engine.

You should keep all receipts and maintenance records covering the performance of regular maintenance in the event questions arise. These receipts and maintenance records should be transferred to each subsequent owner of the engine. ROBIN AMERICA reserves the right to deny warranty coverage if the engine has not been properly maintained. Warranty claims will not be denied, however, solely because of the lack of required maintenance or failure to keep maintenance records.

MAINTENANCE, REPLACEMENT OR REPAIR OF EMISSION CONTROL DEVICES AND SYSTEMS MAY BE PERFORMED BY ANY REPAIR ESTABLISHMENT OR INDIVIDUAL;

HOWEVER, WARRANTY REPAIRS MUST BE PERFORMED BY A SERVICE DEALER AUTHORIZED BY ROBIN AMERICA. THE USE OF PARTS THAT ARE NOT EQUIVALENT IN PERFORMANCE AND DURABILITY TO AUTHORIZED PARTS MAY IMPAIR THE EFFECTIVENESS OF THE EMISSION CONTROL SYSTEM AND MAY HAVE A BEARING ON THE OUTCOME OF A WARRANTY CLAIM.

If other than the parts authorized by ROBIN AMERICA are used for maintenance replacements or for the repair of components affecting emission control, you should assure yourself that such parts are warranted by their manufacturer to be equivalent to the parts authorized by ROBIN AMERICA in their performance and durability.

HOW TO MAKE A CLAIM

All repair qualifying under this limited warranty must be performed by a service dealer authorized by ROBIN AMERICA. In the event that any emission-related part is found to be defective during the warranty period, you shall notify Robin America customer service department at 1-800-277-6246 and you will be advised of the appropriate warranty service dealer or service providers where the warranty repair can be performed.

FOREWORD

Thank you for purchasing a Robin generator.

This manual covers operation and maintenance of the Robin generators. All information in this publication is based on the latest production information available at the time of approval for printing.

Pay special attention to statements preceded by the following words:

DANGER

Indicates a possibility of death or serious injury if instructions are not followed.

WARNING

Indicates a strong possibility of severe personal injury, loss of life and equipment damage if instructions are not followed.

[CAUTION]

Indicates a possibility of personal injury or equipment damage if instructions are not followed.

NOTE :

Gives helpful information.

If a problem should arise, or if you have any questions about the generator, consult an authorized dealer or service shop

WARNING

- **The generator is designed to give safe and dependable service if operated according to instructions.**
- **Do not operate the generator before you have read and understood the instructions. Failure to do so could result in death, personal injury or equipment damage.**

CONTENTS

| | |
|-----------------------------|----|
| 1. SAFETY PRECAUTIONS | 1 |
| 2. SPECIFICATIONS | 3 |
| 3. COMPONENTS | 4 |
| 4. PRE-OPERATION CHECKS | 7 |
| 5. OPERATING PROCEDURES | 11 |
| 6. WATTAGE INFORMATION | 22 |
| 7. SPARK ARRESTER | 24 |
| 8. MAINTENANCE SCHEDULE | 25 |
| 9. "HOW-TO" MAINTENANCE | 27 |
| 10. PREPARATION FOR STORAGE | 31 |
| 11. TROUBLESHOOTING | 32 |
| 12. WIRING DIAGRAM | 33 |

1. SAFETY PRECAUTIONS

Please make sure you review each precaution carefully.

⚠ WARNING

Do not operate the generator near gasoline or gaseous fuel because of the potential danger of explosion or fire.

Do not fill the fuel tank with fuel while the engine is running. Do not smoke or use open flame near the fuel tank. Be careful not to spill fuel during refueling. If fuel is spilt, wipe it off and let dry before starting the engine.



⚠ WARNING

Do not place in flammables near the generator.

Be careful not to place fuel, matches, gunpowder, oily cloths, straw, trash, or any other in flammables near the generator.

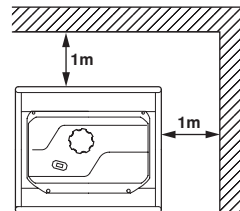

⚠ WARNING

Do not operate the generator inside a room, cave, tunnel, or other insufficiently ventilated area.

Always operate it in a well-ventilated area, otherwise the engine may become overheated, and the poisonous carbon monoxide gas, an odorless, colorless, poison gas, contained in the exhaust gas will endanger human lives.

Operate generator only outdoors and far from open windows, doors, ventilation intakes and other openings.

Keep the generator at least 1 meter (3 feet) away, including overhead, from any structure or building use.

⚠ WARNING

Do not enclose the generator nor cover it with a box.

The generator has a built-in forced air cooling system, and may become overheated if it is enclosed.

If generator has been covered to protect it from the weather during non use, be sure to remove it and keep it well away from the area during generator use.

⚠ WARNING

Operate the generator on a level surface.

It is not necessary to prepare a special foundation for the generator.

However, the generator will vibrate on an irregular surface, so choose a level place without surface irregularities.

If the generator is tilted or moved during operation, fuel may spill and / or the generator may tip over, causing a hazardous situation.

Proper lubrication cannot be expected if the generator is operated on a steep incline or slope. In such a case, piston seizure may occur even if the oil is above the upper level.

⚠ WARNING

Pay attention to the wiring or extension cords from the generator to the connected device.

If the wire is under the generator or in contact with a vibrating part, it may break and possibly cause a fire, generator burnout, or electric shock hazard.

Replace damaged or worn cords immediately.



⚠ WARNING

Do not operate in rain, in wet or damp conditions, or with wet hands.
The operator may suffer severe electric shock if the generator is wet due to rain or snow.

⚠ WARNING

If wet, wipe and dry it well before starting. Do not pour water directly over the generator, nor wash it with water.

⚠ WARNING

Be extremely careful that all necessary electrical grounding procedures are followed during each and every use. Failure to do so can be fatal.

⚠ WARNING

Do not contact the generator to a commercial power line. Connection to a commercial power line may short circuit the generator and ruin it or cause electric shock hazard. Use the transfer switch for connecting to domestic circuit.



⚠ WARNING

No smoking while handling the battery. The battery emits flammable hydrogen gas, which can explode if exposed to electric arcing or open flame. Keep the area well-ventilated and keep open flames/sparks away when handling the battery.



⚠ WARNING

Engine becomes extremely hot during and for some time after operation. Keep combustible materials well away from generator area. Be very careful not to touch any parts of the hot engine especially the muffler area or serious burns may result.



⚠ WARNING

Keep children and all bystanders at a safe distance from work areas.

⚠ WARNING

It is absolutely essential that you know the safe and proper use of the power tool or appliance that you intend to use. All operators must read, understand and follow the tool/appliance owners manual. Tool and appliance applications and limitations must be understood. Follow all directions given on labels and warnings. Keep all instruction manuals and literature in a safe place for future reference.

⚠ WARNING

Use only "LISTED" extension cords.
When a tool or appliance is used outdoors, use only extension cords marked "For Outdoor Use".
Extension cords, when not in use should be stored in a dry and well ventilated area.

⚠ WARNING

Always switch off generator's AC circuit breaker and disconnect tools or appliances when not in use, before servicing, adjusting, or installing accessories and attachments.

⚠ CAUTION

Make sure the engine is stopped before starting any maintenance, servicing or repair.
Make sure maintenance and repair of the generator set are performed by properly trained personnel only.

2. SPECIFICATIONS

| MODEL | | RGX3000 | RGX3800 | RGX5100 | RGX7100 | RGX7800 |
|-----------------------|------------------------------|---|---------------------------|------------------|----------------|------------------|
| Generator | Type | Brush, self-exciting, 2-poles, single phase | | | | |
| | Voltage regulating system | AVR type | | | | |
| | AC Output | | | | | |
| | Rated voltage-Frequency V-Hz | 120-60 | 120/240-60 | | | |
| | Rated current A | 20 | 24.2 / 12.1 | 35 / 17.5 | 41.7 / 20.8 | 50 / 25 |
| | Rated output VA (W) | 2400 | 2900 | 4200 | 5000 | 6000 |
| | Rated power factor | 1.0 | | | | |
| | Safety device type | Fuse-less circuit breaker | | | | |
| | DC Output | | | | | |
| | Rated voltage V | 12 | | | | |
| Rated current A | 8.3 | | | | | |
| Safety device type | Fuse-less circuit breaker | | | | | |
| Engine | Model | EX17D | EX21D | EX30D | EX35D | EX40D |
| | Type | ROBIN, Air-cooled, 4-stroke, OHC, Gasoline Engine | | | | |
| | Displacement mL | 169 | 211 | 287 | 404 | |
| | Fuel | Automotive Unleaded Gasoline | | | | |
| | Fuel tank capacity L | 12.8 (16.6)*1 | | 17.8 (21.5)*1 | | 22.0 (27.5)*1 |
| | Engine oil capacity L | 0.6 | | 1.0 | | 1.2 |
| | Spark plug | BR-6HS (NGK) | | | | |
| | Starting system | Recoil starter | Electric starter / Recoil | | | |
| Direction of rotation | Counter - clockwise | | | | | |
| Dimension | Length mm | 600 | 620 (870)*2 | 675 (925)*2 | 725 (975)*2 | |
| | Width mm | 420 | 450 | 510 | 530 | |
| | Height mm | 500 | 500 | 570 | 580 | |
| Dry weight kg | 47 | 52 (57.5)*3 | 69 (79)*3 | 88 (98)*3 | 91 (101)*3 | |

Specifications are subject to change without notice.

*1: () shows the filled amount up to the "LEVEL" position.

*2: () shows dimensions with Battery frame.

*3: () shows dry weight with Electric starter.

3. COMPONENTS

RGX3000, 3800, 5100

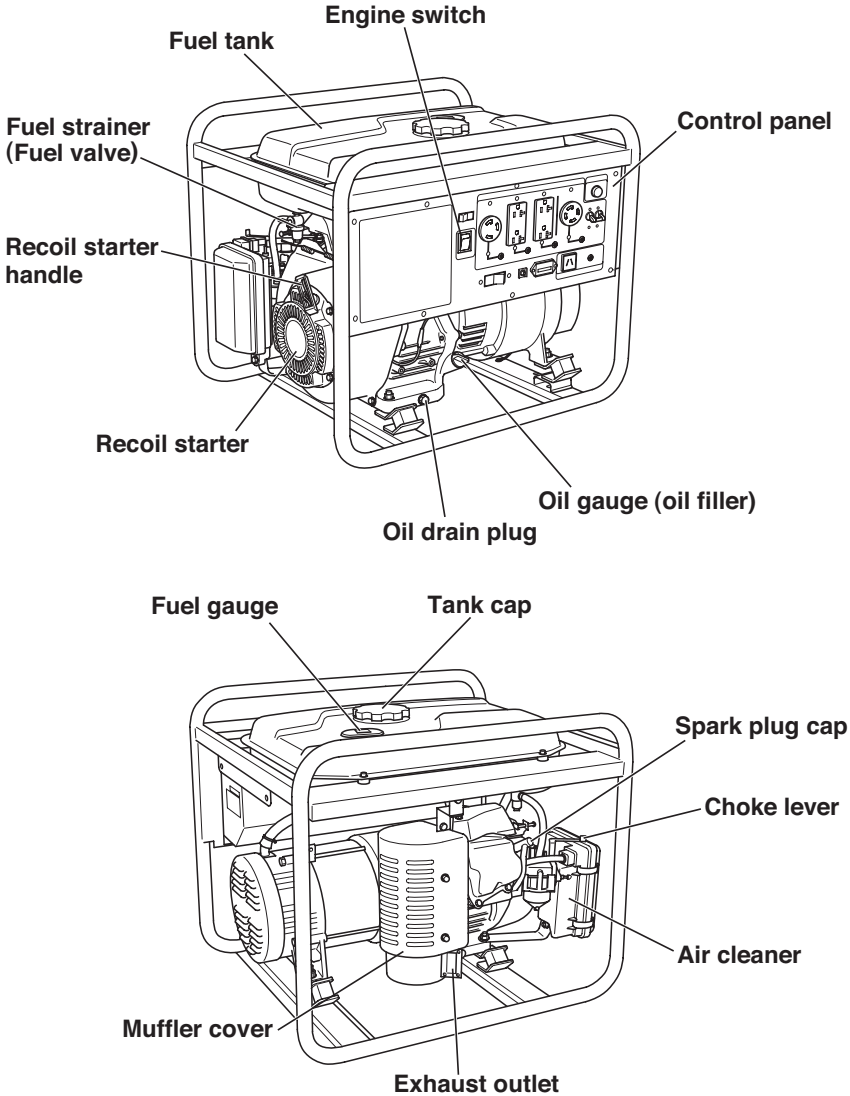

RGX7100, 7800

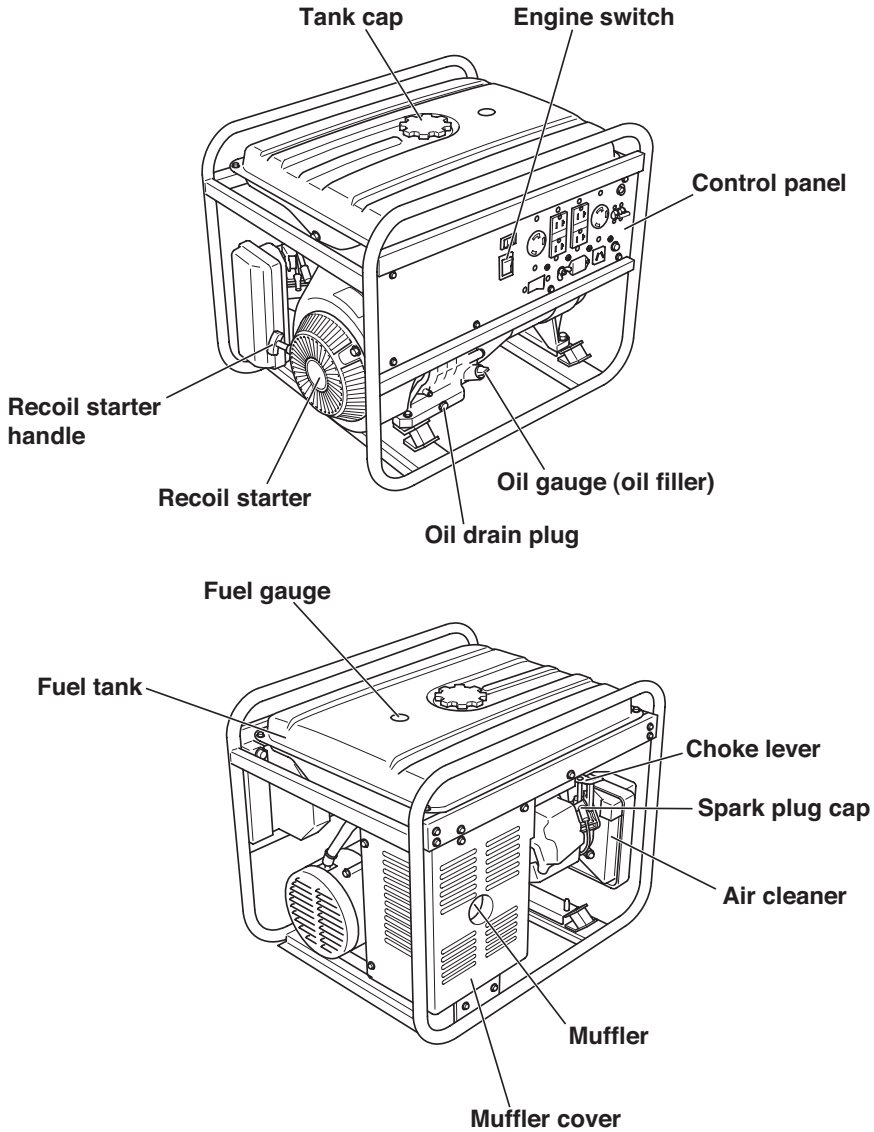

CONTROL PANEL

(RGX3000)

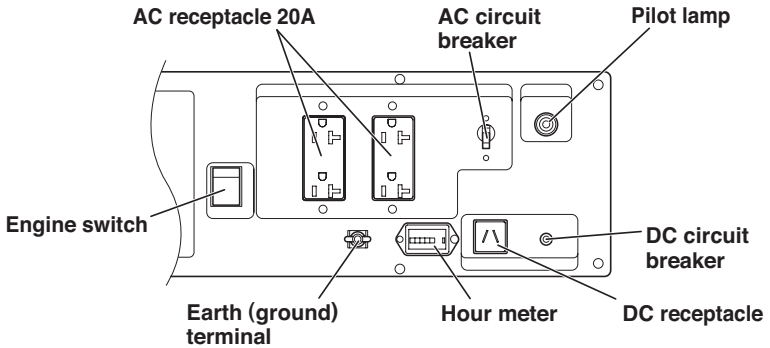

(RGX3800)

[Electric starter model]

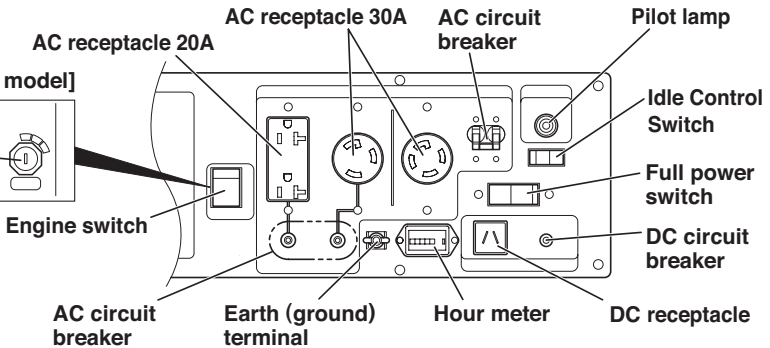
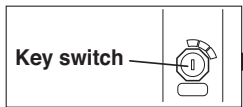

(RGX5100, 7100, 7800)

[Electric starter model]

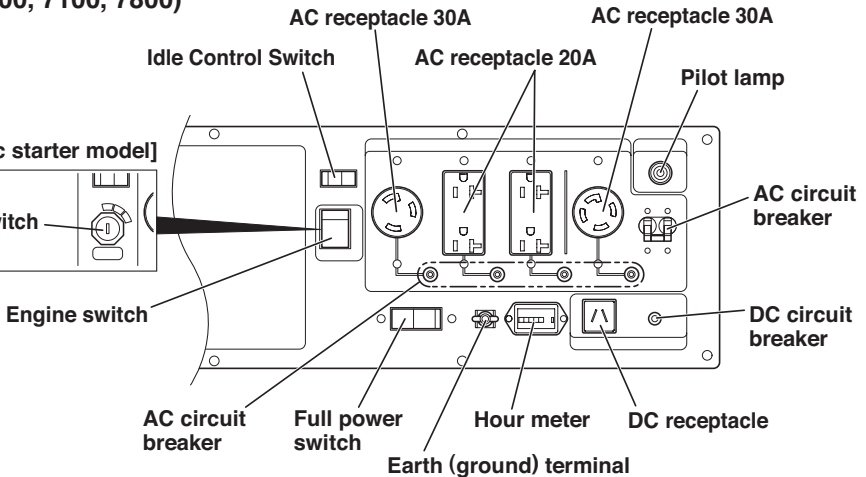
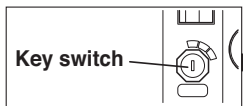

4. PRE-OPERATION CHECKS

CHECK ENGINE OIL

Before checking or refilling oil, be sure generator is located on stable and level surface with engine stopped.

- Remove oil filler cap and check the engine oil level.
- If oil level is below the lower level line, refill with suitable oil (see table) to upper level line. Do not screw in the oil filler cap when checking oil level.
- Change oil if contaminated.
(See "How-To" Maintenance.)

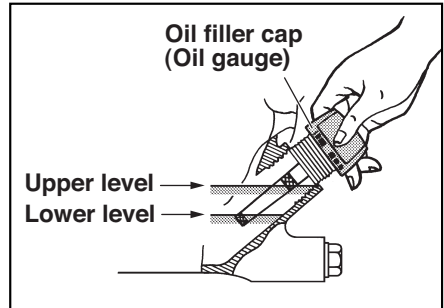

Oil capacity (Upper level) : L (U.S. gal)

| | |
|---------|------------|
| RGX3000 | 0.6 (0.15) |
| RGX3800 | 0.6 (0.15) |
| RGX5100 | 1.0 (0.26) |
| RGX7100 | 1.2 (0.32) |
| RGX7800 | 1.2 (0.32) |

Recommended engine oil :

Use 4-stroke automotive detergent oil of API service class **SE** or higher grade (**SG, SH** or **SJ** is recommended). **SAE 10W-30** or **10W-40** is recommended for general, all-temperature use. If single viscosity oil is used, select the appropriate viscosity for the average temperature in your area.

| | | | | | | | |
|---------------------|-----------|-----------|---------|----------|----------|----------|---------------|
| Single grade | 5W | 10W | 20W | #20 | #30 | #40 | |
| | | | | | | | |
| Multigrade | 10W-30 | | | | | | |
| | 10W-40 | | | | | | |
| Ambient temperature | -20 -4 | -10 14 | 0 32 | 10 50 | 20 68 | 30 86 | 40°C 104°F |

CHECK ENGINE FUEL.

⚠ WARNING

Do not refuel while smoking or near open flame or other such potential fire hazards. Otherwise fire accident may occur.

NOTE :

THIS ENGINE IS CERTIFIED TO OPERATE ON AUTOMOTIVE UNLEADED GASOLINE.

- Check fuel level at fuel level gauge.
- If fuel level is low, refill with unleaded automotive gasoline.
- Be sure to use the fuel filter screen on the fuel filter neck.

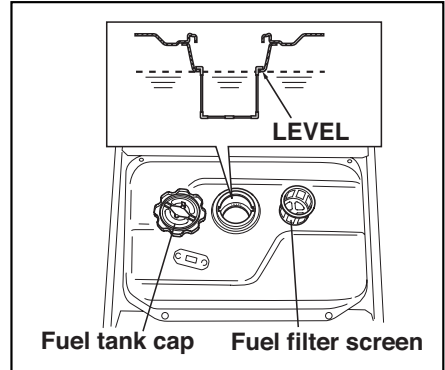

Fuel Amount

up to "LEVEL" position : (L)

| | |
|---------|------|
| RGX3000 | 12.8 |
| RGX3800 | 12.8 |
| RGX5100 | 12.8 |
| RGX7100 | 22.0 |
| RGX7800 | 22.0 |

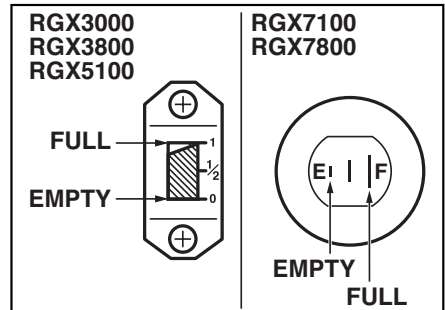

⚠ WARNING

Make sure you review each warning in order to prevent fire hazard.

- Do not refill tank while engine is running or hot.
- Close fuel valve before refueling with fuel.
- Be careful not to admit dust, dirt, water or other foreign objects into fuel.
- Wipe off spilt fuel thoroughly before starting engine.
- Keep open flames away.

CHECKING COMPONENT PARTS

Check following items before starting engine:

- Fuel leakage from fuel hose, etc.
- Bolts and nuts for looseness.
- Components for damage or breakage.
- Generator not resting on or against any adjacent wiring.

CHECK GENERATOR SURROUNDINGS

⚠ WARNING

Make sure you review each warning in order to prevent fire hazard.

- Keep area clear of in flammables or other hazardous materials.
- Keep generator at least 3 feet (1 meter) away from buildings or other structures.
- Only operate generator in a dry, well ventilated area.
- Keep exhaust pipe clear of foreign objects.
- Keep generator away from open flame. No smoking!
- Keep generator on a stable and level surface.
- Do not block generator air vents with paper or other material.

BATTERY INSTALLATION (Electric Starter Model)

Recommended Battery

Type ; Lead-acid battery

Capacity (Ah/5hr) ; 12V-21AH or more

Size ; Less than 185(L) x 125(W) x 160(H) mm

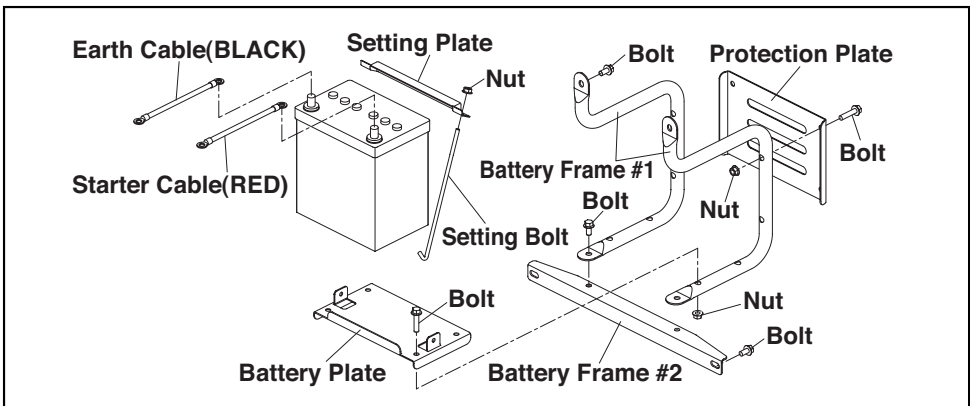

⚠ WARNING

Death, personal injury and/or property damage may occur unless instructions are followed carefully.

- Use battery of recommended capacity.
- Turn the starter switch to the "STOP" position when mounting or dismantling battery. When mounting battery, connect the positive (+) cable first and then the negative (-) cable to the battery. Be careful not to short battery cables. When dismantling battery, disconnect negative (-) cable first.

RED CABLE : To positive (+) terminal

BLACK CABLE : To negative (-) terminal

- Should the connection be made in incorrect manner, the generator will be broken.
- Tighten bolts and nuts on terminals securely so they will not be loosened by vibration.
- Disconnect battery cables when charging battery.

GROUNDING THE GENERATOR

- To ground the generator to the earth, connect the grounding lug of the generator to the grounding spike driven into the earth or to the conductor which has been already grounded to the earth.
- If such grounding conductor or grounding electrode is unavailable, connect the grounding lug of the generator to the grounding terminal of the using electric tool or appliance.

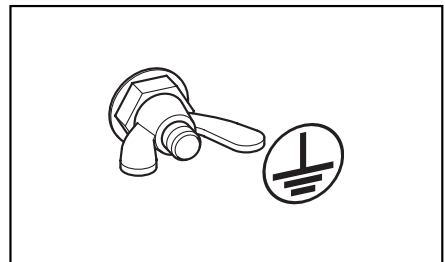
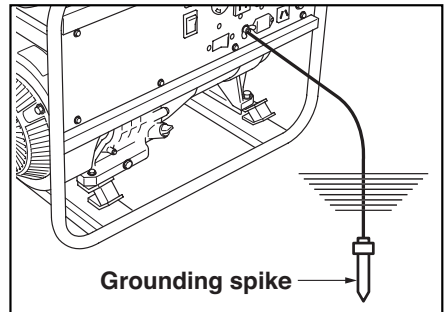

5. OPERATING PROCEDURES

STARTING THE GENERATOR

[CAUTION]

Check the oil level before each operations as outlined by the article "CHECK ENGINE OIL"

(a) Turn the Engine switch to the position "ON".

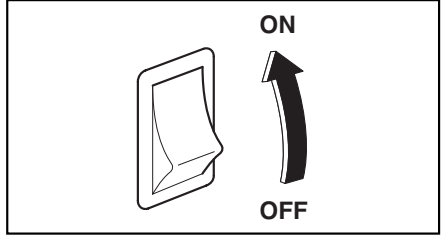

(b) Turn the AC circuit breaker to the position "OFF".

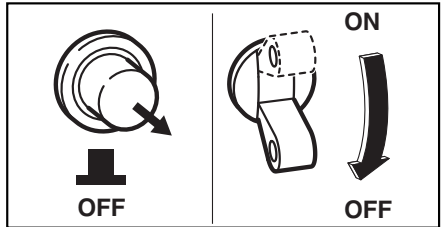

(c) Open the fuel valve.

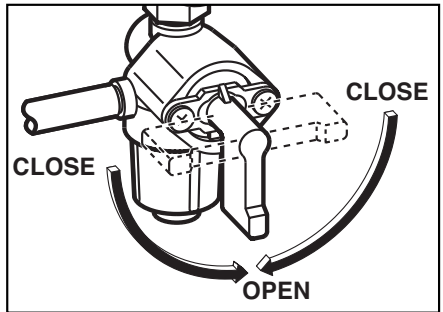

(d) Set choke lever to close if the engine is cold.

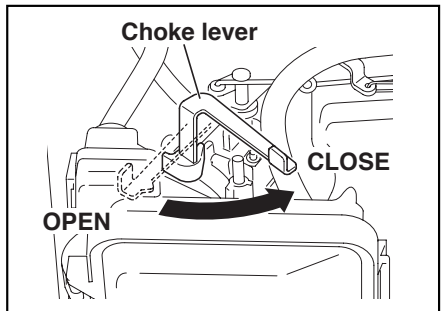

(e) **[Recoil starter model]**

Pull the starter handle slowly until passing the compression point (resistance will be felt), then return the handle to its original position and pull briskly.

- If the engine fails to start after several attempts, repeat above procedures with choke lever returned to "OPEN" position.
- Do not fully pull out the rope.
- After starting, allow the starter handle to return to its original position while still holding the handle.

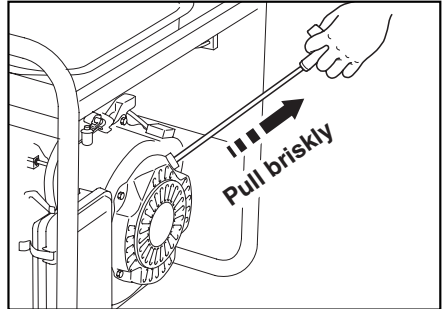

(f) **[Electric starter model]**

Insert the key into the key switch and turn it clockwise to the "RUN" position to start the engine.

Then turn the key further to the "START" position. The engine will be started by starting motor.

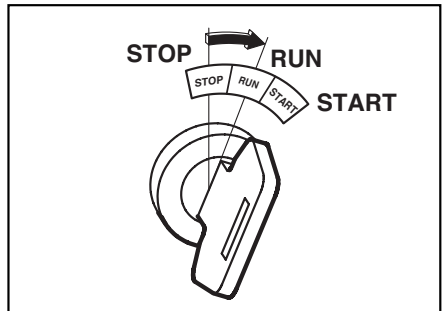

[CAUTION]

- Do not run the starting motor over 5 seconds continuously. If the engine fails to start, return the key to the "RUN" position and wait about 10 seconds then start again.
- Do not turn the key switch to "START" position when the engine is running to prevent damage of starting motor.
- When starting the engine by recoil starter, set the key switch at the "ON" position and pull the starter handle.

- (g) After the engine started, return the choke lever gradually to "OPEN" position.

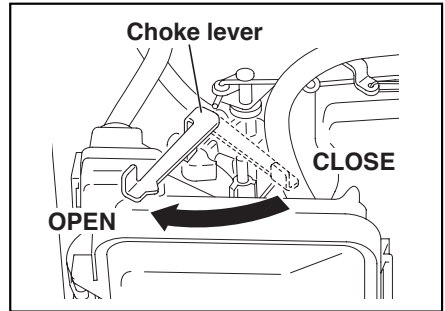

- (h) Warm up the engine without a load for a few minutes.

USING ELECTRIC POWER

WARNING

- Make sure that the appliance is switched OFF before connecting it to the generator.
- Do not move the generator while it is running.
- Be sure to ground the generator if the connected appliance is grounded. Failure to ground unit may lead to electrical shock.

(1) AC APPLICATION

- Make sure the pilot lamp is turned on.
- Turn off the switch (es) of the electrical appliance (s) before connecting to the generator.
- Insert the plug (s) of the electrical appliance(s) into the receptacle.

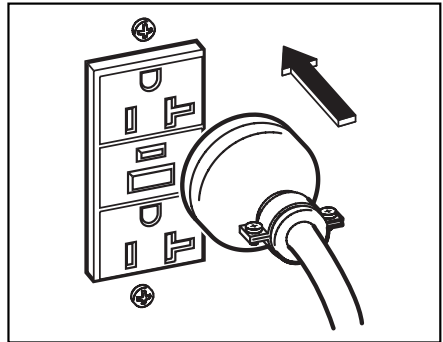

- Check the amperage of the receptacles used referring to **TABLE 1**, and be sure not to take a current exceeding the specified amperage.
- Be sure that the total wattage of all appliances dose not exceed the rated output of the generator.



| Style | Ampere | Receptacle | AC plug | Description |
|---|-----------|--------------|--------------|---|
|  | up to 20A | NEMA 5-20R | NEMA 5-20P | GFCI (Ground Fault Circuit Interrupter) Receptacle, duplex (REC1) |
|  | up to 30A | NEMA L5-30R | NEMA L5-30P | Locking Receptacle (REC3) |
|  | up to 30A | NEMA L14-30R | NEMA L14-30P | Locking Receptacle (REC4) |

TABLE 1

⚠ WARNING

- To take power out from the **TWIST LOCK RECEPTACLE**, insert the plug into the receptacle, and turn it clockwise to the lock position.
- Be sure to ground the generator if the connected electrical device is grounded.

**NOTE :**

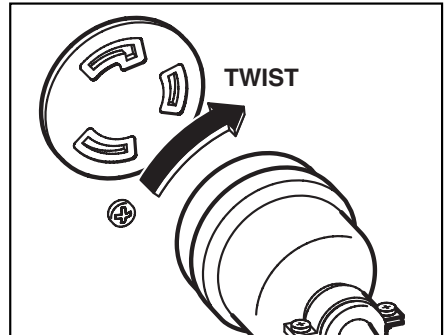
When the AC circuit breaker turns off during operation, the generator is overloaded or the appliance is defective. Stop the generator immediately, check the appliance and / or generator for overloading or detect and have repaired as necessary by Robin dealer or service shop.

[CAUTION]

The duplex 120V receptacle is protected by a GFCI (Ground Fault Circuit Interrupter). GFCI shuts off the output current from the duplex 120V receptacle when a ground fault occurs in the generator or the appliance. Please note that other receptacles are not protected by GFCI.

(d) Turn the AC circuit breaker to the position "ON".

(e) Turn on the switch of the appliance.

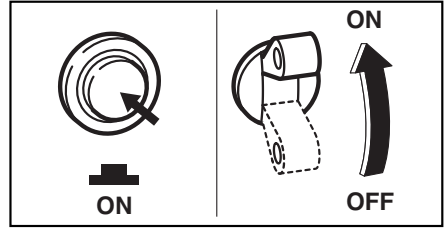

GFCI RECEPTACLE

After starting the engine, check the GFCI for proper functioning by the following test procedure.

- Push blue TEST button, The red RESET button will pop out exposing the word TRIP. Power is now off at the outlets protected by the GFCI, indicating that the device is functioning properly.
- If TRIP dose not appear when testing, do not use the generator. Call a qualified electrician.
- To restore power, push RESET button.

WARNING

If the **RESET** button pops out during operation, stop the generator immediately and call a qualified electrician for checking generator and the appliances.

FULL POWER SWITCH (Except RGX3000)

Select the voltage using the FULL POWER SWITCH in accordance with the electrical appliance.
Refer to **TABLE 2**.

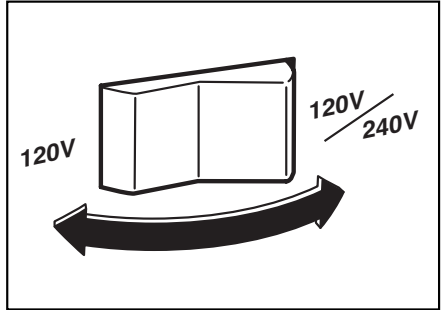

[CAUTION]

Change the **FULL POWER SWITCH** after turning the **AC circuit breaker** to "OFF".

| Switch position | Lower Voltage Receptacle | Higher Voltage Receptacle |
|-----------------|--------------------------------|-----------------------------|
| 120V | Activated full rated output | N.A |
| 120/240V | Activated half of rated output | Activated full rated output |

TABLE 2

IDLE CONTROL SWITCH (Except RGX3000)

IDLE CONTROL SWITCH automatically reduces engine speed when load is OFF, and automatically increases engine speed to rated r.p.m. when load is ON.

IDLE CONTROL SWITCH provides fuel economy and low noise operation at no-load running.

(1) HOW TO USE IDLE CONTROL SWITCH

- Start the engine with IDLE CONTROL SWITCH off.

NOTE :

Warm up the engine without a load for a few minutes.

- Turn IDLE CONTROL SWITCH on.

(2) CHECKING THE OPERATION

When IDLE CONTROL SWITCH does not operate normally, please check following :

- Overloaded ?

Please make it sure that the generator is not overload.

NOTE :

Most induction loads such as electric motors require three to five times more wattage than their ratings during starting.

This starting wattage should not exceed the rated output of the generator for proper operation of IDLE CONTROL SWITCH.

- Turn IDLE CONTROL SWITCH off when the IDLE CONTROL SWITCH does not work normally under the rated output.

NOTE :

The IDLE CONTROL SWITCH may not operate when the applied load is under 40W. In such cases turn the IDLE CONTROL SWITCH off.

(3) STOPPING THE ENGINE

- Turn off the switch of load.
- Switch off generator's AC breaker.
- Disconnect tool or appliance.
- Turn the IDLE CONTROL SWITCH off.
- Turn the STOP SWITCH to the position "O" (OFF).

NOTE :

Allow the engine about 3 minutes to cool down at no-load before stopping.

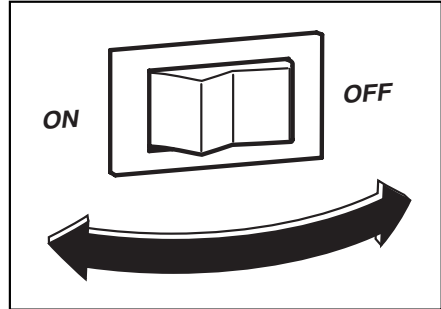

(2) DC APPLICATION
(Only for charging 12 volt battery)

DC receptacle (Only for charging 12 volt battery)

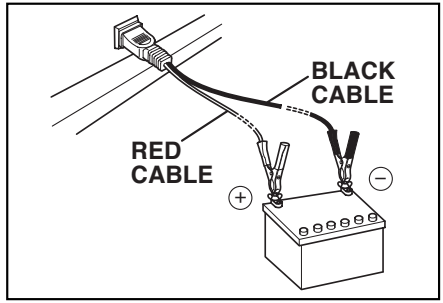

For charging 12 voltage battery, 12V-8.3A (100W) of maximum AC power can be taken out from the DC receptacle by means of the exclusive DC cable.



The exclusive DC cable is come with your generator set (included in the package).

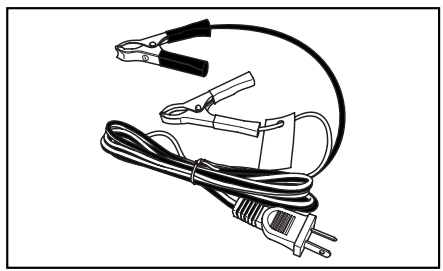

DC Circuit Breaker

DC circuit breaker is turned off to shut down the DC power, when the DC is over the usage range or the battery is defective.

Check the generator and/or battery for overloading or defect, and turn on the DC circuit breaker after no problem and defect are found out.

Connection of exclusive DC cable :

- Connect positive (red) clip of DC cable to positive (+) terminal on battery.
- Connect negative (black) clip of DC cable to negative (-) terminal on battery.

Battery Charging Procedures :

- 1) Stop engine.
- 2) Remove all connections from battery.
- 3) Insert the plug of exclusive DC cable into DC receptacle.
- 4) Connect positive (red) clip of DC cable to positive (+) terminal on battery, and then connect negative (black) clip of DC cable to negative (-) terminal on battery.
- 5) Take out all plugs at the battery electrolyte fluid filler ports.
- 6) Check the electrolyte fluid level, and refill the distilled water as necessary.
- 7) Start engine.
- 8) Make sure that the pilot lamp is turned on.
- 9) Make sure that the DC circuit breaker is in the ON position.
- 10) Battery charging will be started.

[CAUTION]

- **Do not use both AC and DC output at the same time.**
- **Install correct positive (red) or negative (black) cable to the correct polarity on the battery.**
- **Connect and disconnect DC cable with engine stopped.**
- **An explosive hydrogen gas is discharged through vent holes in the battery during the charging process.
Do not allow spark or open flame around the generator or battery during the charging process.**
- **Electrolyte fluid contains sulphuric acid, and so the fluid can burn eyes and clothing. Be extremely careful to avoid contact.
If injured, wash the affected area immediately with large quantities of water and consult a doctor for treatment.**
- **Charging time is varied according to the kind of battery and discharged level of battery.
Measure the specific gravity of electrolyte fluid by means of hydrometer every one hour during battery charging.
Make sure if the DC circuit breaker is not turned off.
Battery charging is completed when the specific gravity is in the range of 1.26 to 1.28.**

STOPPING THE GENERATOR

- (a) Turn off the power switch of the electric equipment and unplug the cord from receptacle of the generator.
- (b) Turn the AC circuit breaker to the "OFF" position.
- (c) Allow the engine about 3 minutes to cool down at no-load before stopping.
- (d) **[Recoil starter model]**
Turn the engine switch to the position "OFF".
[Electric starter model]
Turn the key switch to the STOP position.
- (e) Close the fuel valve.

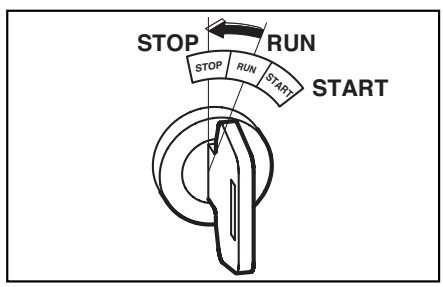
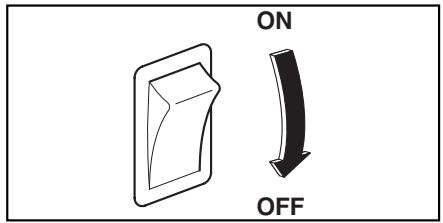
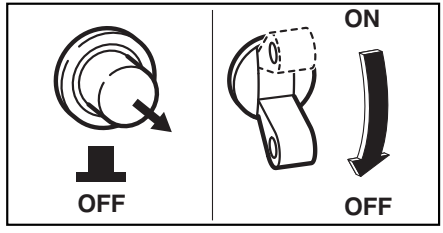

OIL SENSOR

- (a) The oil sensor detects the fall in oil level in the crankcase and automatically stops the engine when the oil level falls below a predetermined level.
- (b) When engine has stopped automatically, switch off generator's AC circuit breaker, and check the oil level.
Refill engine oil to the upper level as instructed on page 7 and restart the engine.
- (c) If the engine does not start by usual starting procedures, check the oil level.

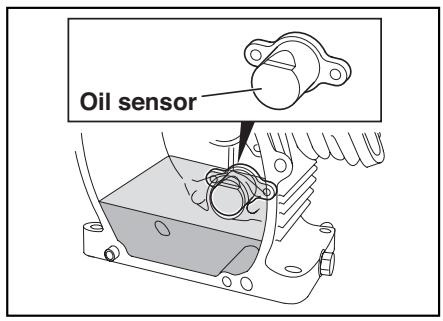
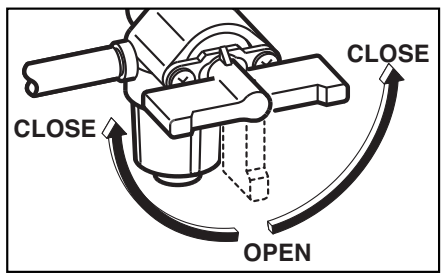

6. WATTAGE INFORMATION

Some appliances need a "surge" of energy when starting.

This means that the amount of electrical power needed to start the appliance may exceed the amount needed to maintain its use.

Electrical appliances and tools normally come with a label indicating voltage, cycles / Hz, amperage (amps) and electrical power needed to run the appliance or tool.

Check with your nearest dealer or service center with questions regarding power surge of certain appliances or power tools.

- Electrical loads such as incandescent lamps and hot plates require the same wattage to start as is needed to maintain use.
- Loads such as fluorescent lamps require 1.2 to 2 times the indicated wattage during start-up.
- Loads for mercury lamps require 2 to 3 times the indicated wattage during start-up.
- Electrical motors require a large starting current. Power requirements depend on the type of motor and its use. Once enough "surge" is attained to start the motor, the appliance will require only 50% to 30% of the wattage to continue running.
- Most electrical tools require 1.2 to 3 times their wattage for running under load during use. For example, a 5,000 watt generator can power a 1800 to 4000 watt electrical tool.
- Loads such as submersible pumps and air compressors require a very large force to start. They need 3 to 5 times the normal running wattage in order to start.
For example, a 5,000 watt generator would only be able to drive a 1,000 to 1,700 watt pump.

NOTE :

The following wattage chart is general guide only. Refer to your specific appliance for correct wattage.

To determine the total wattage required to run a particular electrical appliance or tool, multiply the voltage figure of the appliance/tool by the amperage (amps) figure of same. The voltage and amperage (amps) information can be found on a name plate which is normally attached to electrical appliances and tools.

| Applications | Applicable Wattage(W) | | | | |
|--|-----------------------|---------|---------|---------|---------|
| | RGX3000 | RGX3800 | RGX5100 | RGX7100 | RGX7800 |
| Incandescent lamp, Heater | 2400 | 2900 | 4200 | 5000 | 6000 |
| Fluorescent lamp, Electric tool | 1300 | 1600 | 2300 | 2750 | 3300 |
| Mercury lamp | 950 | 1150 | 1700 | 2000 | 2400 |
| Pump, Compressor | 600 | 700 | 1050 | 1250 | 1500 |

VOLTAGE DROP IN ELECTRIC EXTENSION CORDS

When a long electric extension cord is used to connect an appliance or tool to the generator, a certain amount of voltage drop or loss occurs in the extension cord which reduces the effective voltage available for the appliance or tool.

The chart below has been prepared to illustrate the approximate voltage loss when an extension cord of 300 feet (approx. 100 meters) is used to connect an appliance or tool to the generator.

| Nominal cross section | A.W.G. | Allowable current | No. of strands / strands dia. | Resistance | Current Amp. | | | | | | | |
|-----------------------|----------|-------------------|-------------------------------|------------|--------------|------|-------|------|------|------|------|--------------|
| | | | | | 1A | 3A | 5A | 8A | 10A | 12A | 15A | |
| mm ² | No. | A | No./mm | Ω/100m | 1A | 3A | 5A | 8A | 10A | 12A | 15A | Voltage drop |
| 0.75 | 18 | 7 | 30/0.18 | 2.477 | 2.5V | 8V | 12.5V | — | — | — | — | |
| 1.27 | 16 | 12 | 50/0.16 | 1.486 | 1.5V | 5V | 7.5V | 12V | 15V | 18V | — | |
| 2.0 | 14 | 17 | 37/0.26 | 0.952 | 1V | 3V | 5V | 8V | 10V | 12V | 15V | |
| 3.5 | 12 to 10 | 23 | 45/0.32 | 0.517 | — | 1.5V | 2.5V | 4V | 5V | 6.5V | 7.5V | |
| 5.5 | 10 to 8 | 35 | 70/0.32 | 0.332 | — | 1V | 2V | 2.5V | 3.5V | 4V | 5V | |

7. SPARK ARRESTER

In a dry or wooded area, it is recommendable to use the product with a spark arrester. Some areas require the use of a spark arrester. Please check your local laws and regulations before operating your product.

The spark arrester must be cleaned regularly to keep it functioning as designed. A clogged spark arrester :

- Prevents the flow of exhaust gas
- Reduces engine output
- Increases fuel consumption
- Makes starting difficult

If the engine has been running, the muffler and the spark arrester will be very hot. Allow the muffler to cool before cleaning the spark arrester.

How to remove the spark arrester

1. Remove the flange bolts from the muffler cover and remove the muffler cover.
2. Remove the special screw from the spark arrester and remove the spark arrester from the muffler.

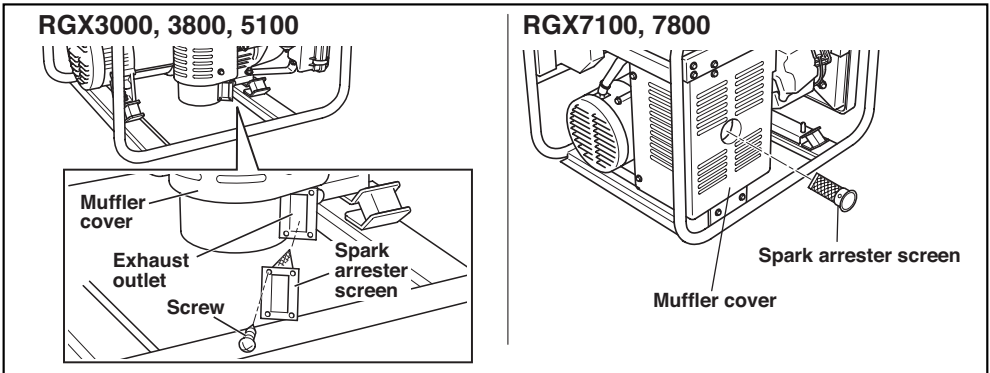

Clean the spark arrester screen

Use a brush to remove carbon deposits from the spark arrester screen. Be careful to avoid damaging the screen.

The spark arrester must be free of breaks and holes. Replace the spark arrester if it is damaged.

Install the spark arrester, and muffler protector in the reverse order of disassembly.

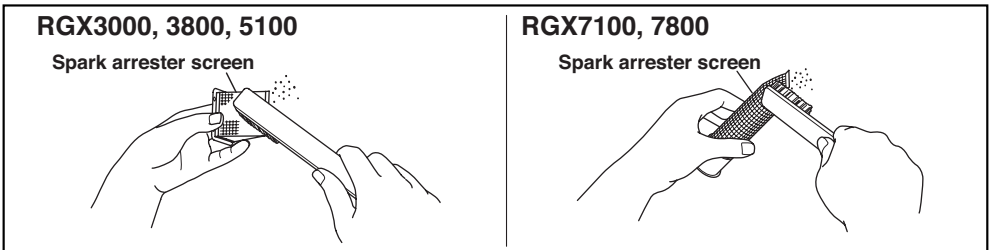

8. MAINTENANCE SCHEDULE

MAINTENANCE, REPLACEMENT, OR REPAIR OF THE EMISSION CONTROL DEVICES AND SYSTEMS MAY BE PERFORMED BY ANY NONROAD ENGINE REPAIR ESTABLISHMENT OR INDIVIDUAL.

DAILY INSPECTION

Before running the generator, check the following service items:

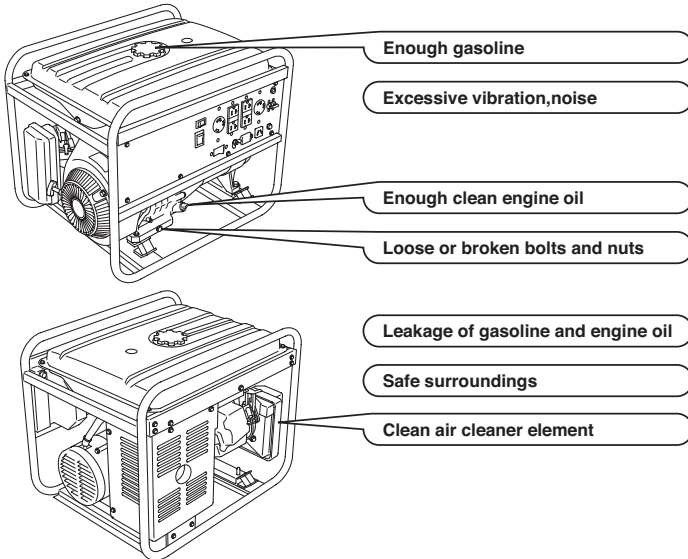

PERIODIC MAINTENANCE

Periodic maintenance is vital to safe and efficient operation of your generator. Check the table below for periodic maintenance intervals.

IT IS ALSO NECESSARY FOR THE USER OF THIS GENERATOR TO CONDUCT THE MAINTENANCE AND ADJUSTMENTS ON THE EMISSION-RELATED PARTS LISTED BELOW TO KEEP THE EMISSION CONTROL SYSTEM EFFECTIVE.

The emission control system consists of the following parts :

- | | | |
|---|--|--|
| (1) Carburetor and internal parts | (4) Air cleaner elements | (8) Exhaust manifold, if applicable |
| (2) Cold start enrichment system, if applicable | (5) Spark plug | (9) Hoses, belts, connectors, and assemblies |
| (3) Intake manifold, if applicable | (6) Magneto or electronic ignition system | |
| | (7) Spark advance/retard system, if applicable | |

The maintenance schedule indicated in the table is based on the normal generator operation. Should the generator be operated in extremely dusty condition or in heavier loading condition, the maintenance intervals must be shortened depending on the contamination of oil, clogging of filter elements, wear of parts, and so on.

Periodic Maintenance Schedule table

| Maintenance Items | Every 8 hours (Daily) | Every 50 hours (Weekly) | Every 200 hours (Monthly) | Every 500 hours | Every 1000 hours |
|--|------------------------------------|-------------------------|---------------------------|-----------------|------------------|
| Clean generator and check bolt and nuts | ● (Daily) | | | | |
| Check and refill engine oil | ● (Refill daily up to upper level) | | | | |
| Change engine oil (*Note1) | ● (Initial 20 hours) | ● (Every 100 hours) | | | |
| Clean spark plug | | ● (Every 100 hours) | | | |
| Clean air cleaner | | ● | | | |
| Clean spark arrester | | ● (Every 100 hours) | | | |
| Replace air cleaner element | | | ● | | |
| Clean fuel filter | | | ● | | |
| Clean and adjust spark plug and electrodes | | | ● | | |
| Replace spark plug | | | | ● | |
| Remove carbon from cylinder head (*Note 2) | | | | ● | |
| Check and adjust valve clearance (*Note 2) | | | | ● | |
| Clean and adjust carburetor (*Note 2) | | | | ● | |
| Check and replace carbon brushes | | | | ● | |
| Replace fuel lines | | | | | ● (Yearly) |
| Overhaul engine (*Note 2) | | | | | ● |
| Check AC receptacles | ● (Daily) | | | | |
| Check DC terminal | ● (Daily) | | | | |
| Check engine switch | ● (Daily) | | | | |
| Check rotor | | | | | ● |
| Check stator | | | | | ● |
| Replace engine mount | | | | | ● |

*Note: 1. Initial oil change should be performed after first twenty (20) hours of operation. Thereafter change oil every hundred (100) hours. Before changing oil, check for a suitable way to dispose of old oil. Do not pour it down into sewage drains, onto garden soil or into open streams. Your local zoning or environmental regulations will give you more detailed instructions on proper disposal.

*Note: 2. As to the procedures for these items, please refer to the SERVICE MANUAL or consult your nearest service dealer.

9. "HOW-TO" MAINTENANCE

ENGINE OIL CHANGE

- Change engine oil every 100 hours.
(For new engine, change oil after 20 hours.)
- (a) Drain oil by removing the drain plug and the oil filler cap while the engine is warm.
- (b) Reinstall the drain plug and fill the engine with oil until it reaches the upper level on the oil filler cap.
- Use fresh and high quality lubricating oil to the specified level as directed on page 7.
If contaminated or deteriorated oil is used or the quantity of the engine oil is not sufficient, the engine damage will result and its life will be greatly shortened.

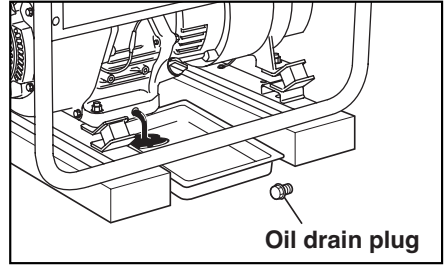

SERVICING THE AIR CLEANER

Maintaining an air cleaner in proper condition is very important. Dirt induced through improperly installed, improperly serviced or inadequate elements damages and wears out engines. Keep the element always clean.

- (a) Remove the bolt of air cleaner cover. (RGX7100, 7800)
Remove the air cleaner cover and cleaner element.
- (b) Urethane form : Wash urethane form element in kerosene or diesel fuel. Then saturate the element in a mixture of 3 parts kerosene or diesel fuel and 1 part engine oil.
Squeeze the element to remove the mixture and install it in the air cleaner.

NOTE :

Instead of washing oil (kerosene), it is possible to wash the urethane foam element in a solution of mild detergent and warm water.

Then rinse the element thoroughly in clean water.

Allow the element to dry thoroughly. Soak the element in clean engine oil and squeeze out excess oil.

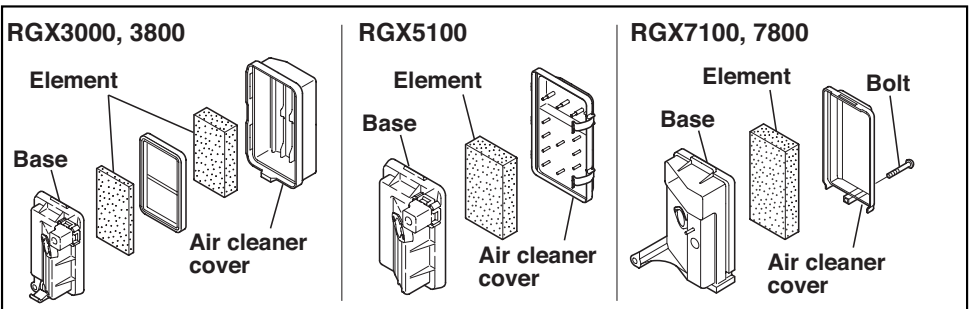

CLEANING AND ADJUSTING SPARK PLUG

- (a) If the plug is contaminated with carbon, remove it using a plug cleaner or wire brush.
- (b) Adjust the electrode gap to 0.6 to 0.7 mm (0.024 to 0.028 in.).

Spark plug : BR-6HS (NGK)

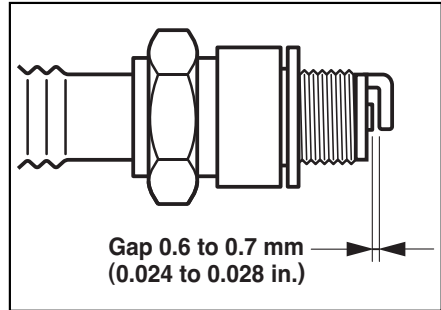

CLEANING FUEL STRAINER

Dirt and water in the fuel are removed by the fuel strainer.

- (a) Remove the strainer cup and throw away water and dirt.
- (b) Clean the screen and strainer cup with gasoline.
- (c) Tightly fasten the cup to main body, making sure to avoid fuel leak.

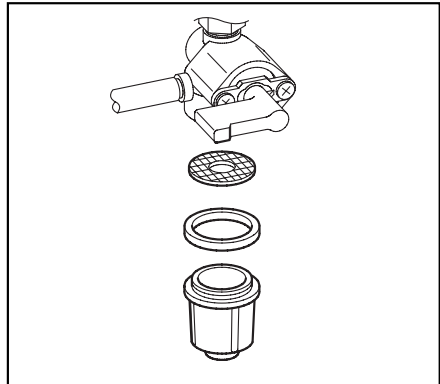

CHECKING CARBON BRUSH

Brush Maintenance Essentials (Effective Length)

The brush is the area which touches the slip ring, and its surface must be kept smooth.

If it is not smooth then carbon and other substances will adhere between the brush and slip ring.

This must be buffed with sandpaper or the like because it is hazardous.

The usable length of the brush is 5~11 mm, so if the brush is 5 mm long or less replace it with a new one.

This is done because if the length of the brush gets any shorter, its contact pressure with the slip ring will decrease, resulting in a drop in generator efficiency and the output voltage.

Check the brush every 500 hours to confirm its length.

In addition, check the brush length if the generator malfunctions, such as when it is not generating power or its voltage is low.

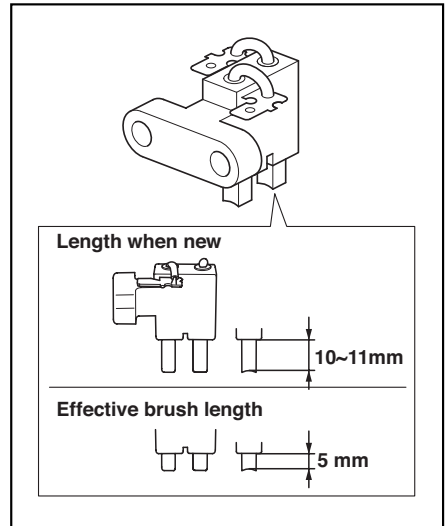

Brush Maintenance Essentials (Disassembly and Assembly)

Disassembly

1. Remove the two flange bolts (M5 x 20), then remove the bracket cover.
2. Remove the two flange bolts (M5 x 16), then remove the brush.

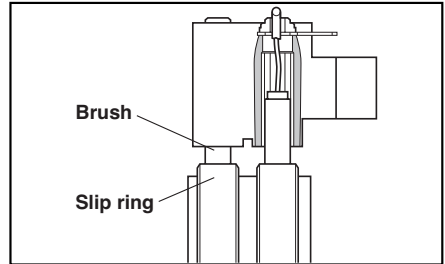

Assembly

1. While pressing the brush against the slip ring, secure it (1.5~2N·m) by tightening it with the two flange bolts (M5 x 16).
When doing so, confirm that the brush is in the proper position relative to the slip ring.
2. Secure the bracket cover (3~4N·m) by tightening it with the two flange bolts (M5 x 20).

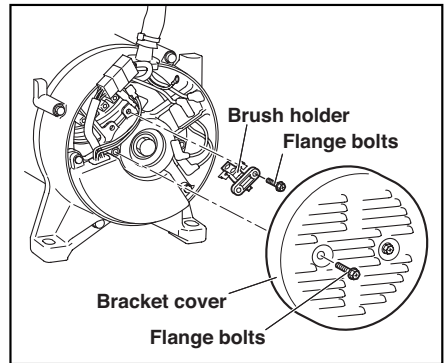

10. PREPARATION FOR STORAGE

The following procedures should be followed prior to storage of your generator for periods of 6 months or longer.

- Drain fuel from fuel tank carefully by disconnecting the fuel line. Gasoline left in the fuel tank will eventually deteriorate making engine-starting difficult.
- Remove the carburetor float chamber and also drain the carburetor.
- Change engine oil.
- Check for loose bolts and screws, tighten them if necessary.

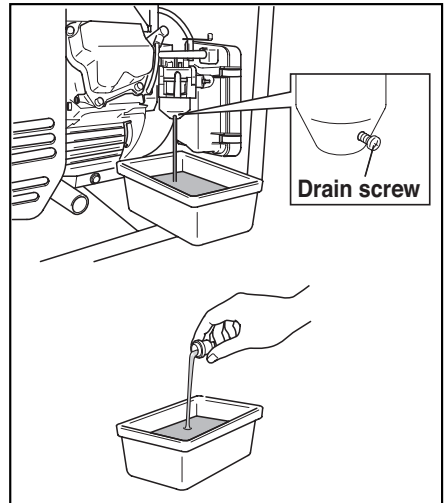

- Clean generator thoroughly with oiled cloth. Spray with preservative if available. **NEVER USE WATER TO CLEAN GENERATOR !**
- Pull starter handle until resistance is felt, leaving handle in that position.
- Store generator in a well ventilated, low humidity area.

11. TROUBLESHOOTING

When generator engine fails to start after several attempts, or if no electricity is available at the output socket, check the following chart. If your generator still fails to start or generate electricity, contact your nearest Robin dealer or service shop for further information or corrective procedures.

When Engine Fails to Start :

| | | |
|--|---|--|
| Check if choke lever is in its proper position. | | Set the choke lever to "CLOSE" position. |
| Check if fuel valve is open. | ↔ | If closed, open fuel valve. |
| Check fuel level. | | If empty, refill fuel tank making sure not to overfill. |
| Check if engine switch is in OFF. | | Turn engine switch to ON. |
| Check to make sure generator is not connected to an appliance. | | If connected, turn off the power switch on the connected appliance and unplug. |
| Check spark plug for loose spark plug cap. | ↔ | If loose, push spark plug cap back into place. |
| Check spark plug for contamination. | | Remove spark plug and clean electrode. |

When No Electricity Is Generated at Receptacle :

| | | |
|---|---|--|
| Check to make sure AC circuit breaker is in the "ON" position. | ↔ | After making sure that the total wattage of the electrical appliance is within permissible limits and there are no defects in the appliance, turn the AC circuit breaker to the "ON" position. If breakers continue to actuate, consult your nearest servicing dealer. |
| Check AC receptacle and DC terminals for loose connection. | | Secure connection if necessary. |
| Check to see if engine starting was attempted with appliances already connected to generator. | ↔ | Turn off switch on the appliance, and disconnect cable from receptacle. Reconnect after generator has been started properly. |
| Low power. | | Carbon brushes are excessively worn |

12. WIRING DIAGRAM

RGX3000 (60Hz-120V)

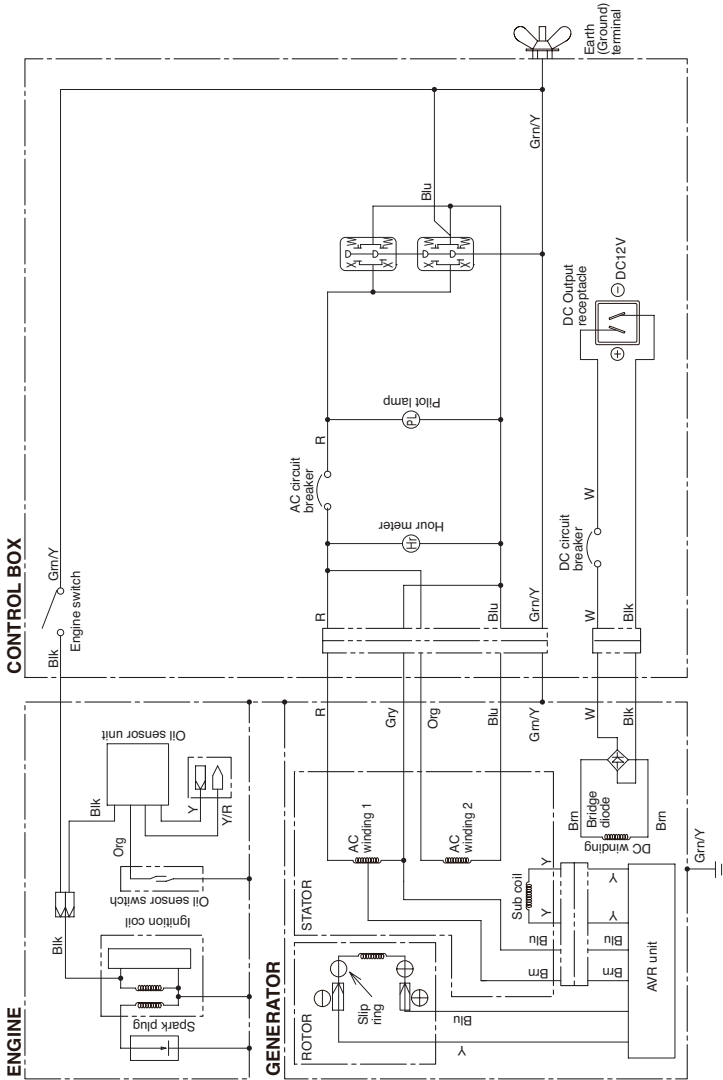

Wiring color code

- Blk : Black
- BlnW : Black/White
- Blu : Blue
- LBlu : Light blue
- Brn : Brown
- BrnW : Brown/White
- Gm : Green
- GmW : Green/White
- Org : Orange
- Gry : Gray
- R : Red
- W : White
- Y : Yellow
- WBk : White/Black
- Gm/Y : Green/Yellow
- Pur : Purple

RGX3800 (60Hz-120/240V)

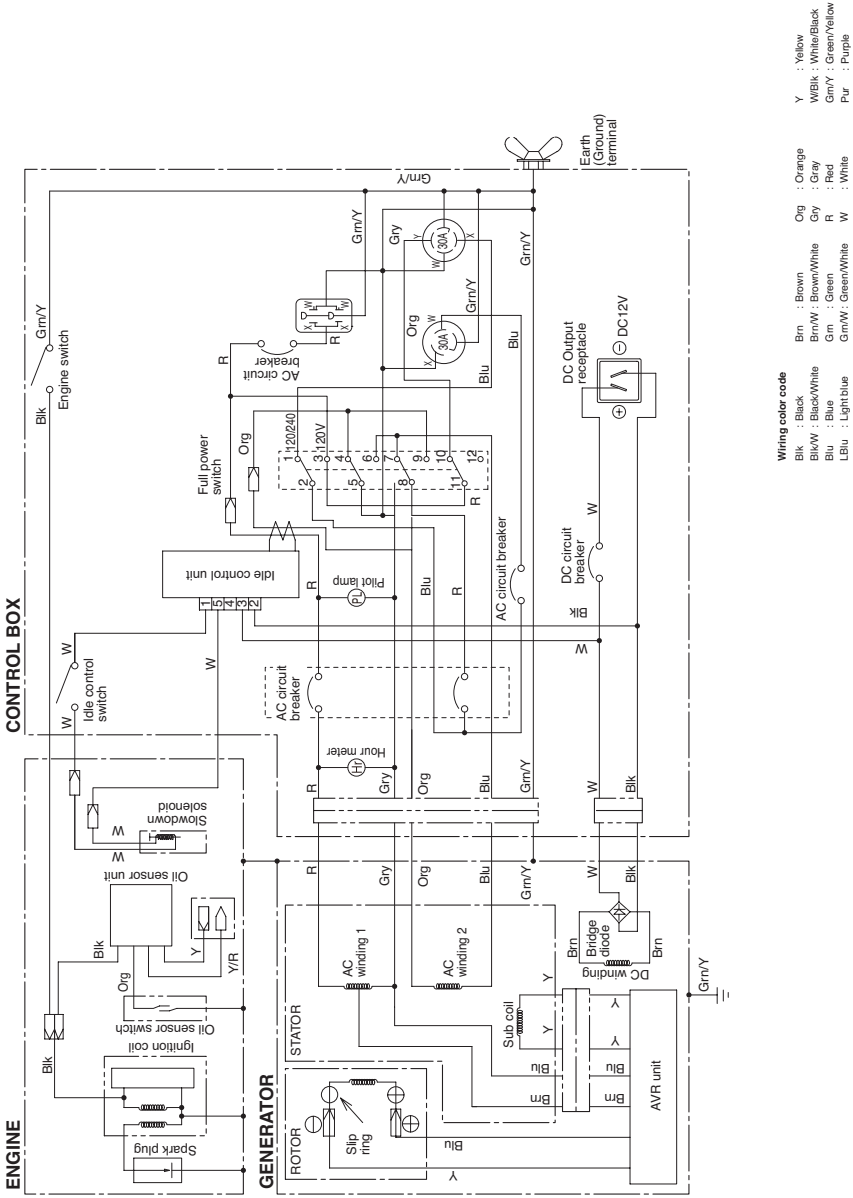

Wiring color code

- Y : Yellow
- WBk : White/Black
- Gm/Y : Green/Yellow
- Pur : Purple
- Brn : Brown
- Bk : Black
- Bk/W : Black/White
- Blu : Blue
- LBlu : Light blue
- Org : Orange
- Gry : Gray
- Brn/W : Brown/White
- Gm : Green
- Gm/W : Green/White
- Blu : Blue
- R : Red
- W : White

RGX3800 [Electric Starter Model] (60Hz-120/240V)

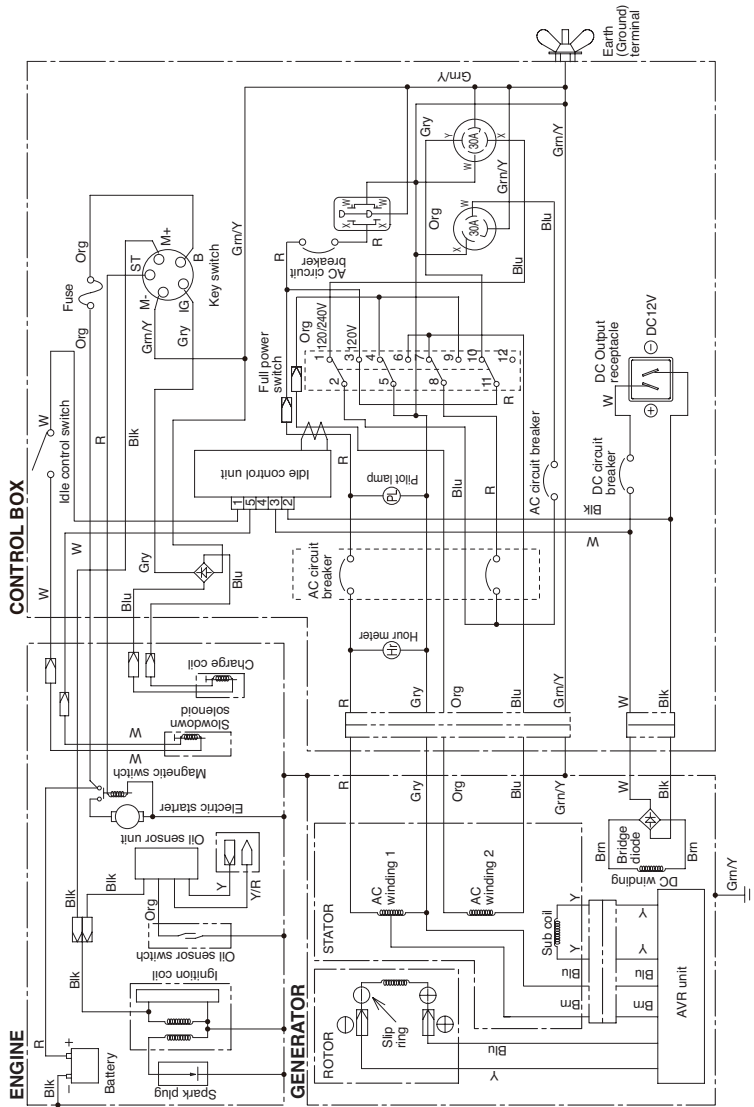

Wiring color code

- Y : Yellow
- Blk : Black
- Blk/W : Black/White
- Blu : Blue
- LBlu : Light blue
- Bm : Brown
- Bm/W : Brown/White
- Gm : Green
- Gm/W : Green/White
- Org : Orange
- Gry : Gray
- R : Red
- W : White
- Y : Yellow
- WBk : White/Black
- Gm/Y : Green/Yellow
- Pur : Purple

RGX5100, 7100, 7800 (60Hz-120/240V)

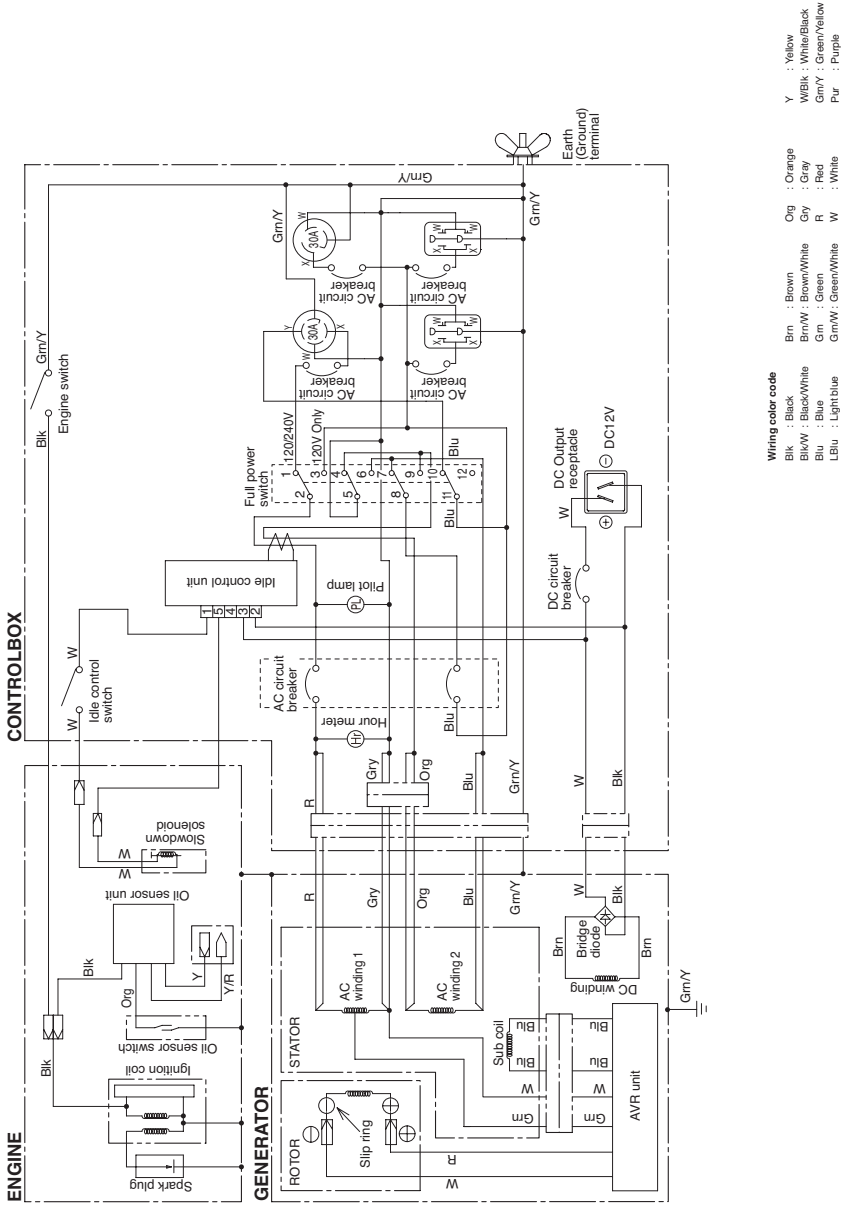

RGX5100, 7100, 7800 [Electric Starter Model] (60Hz-120/240V)

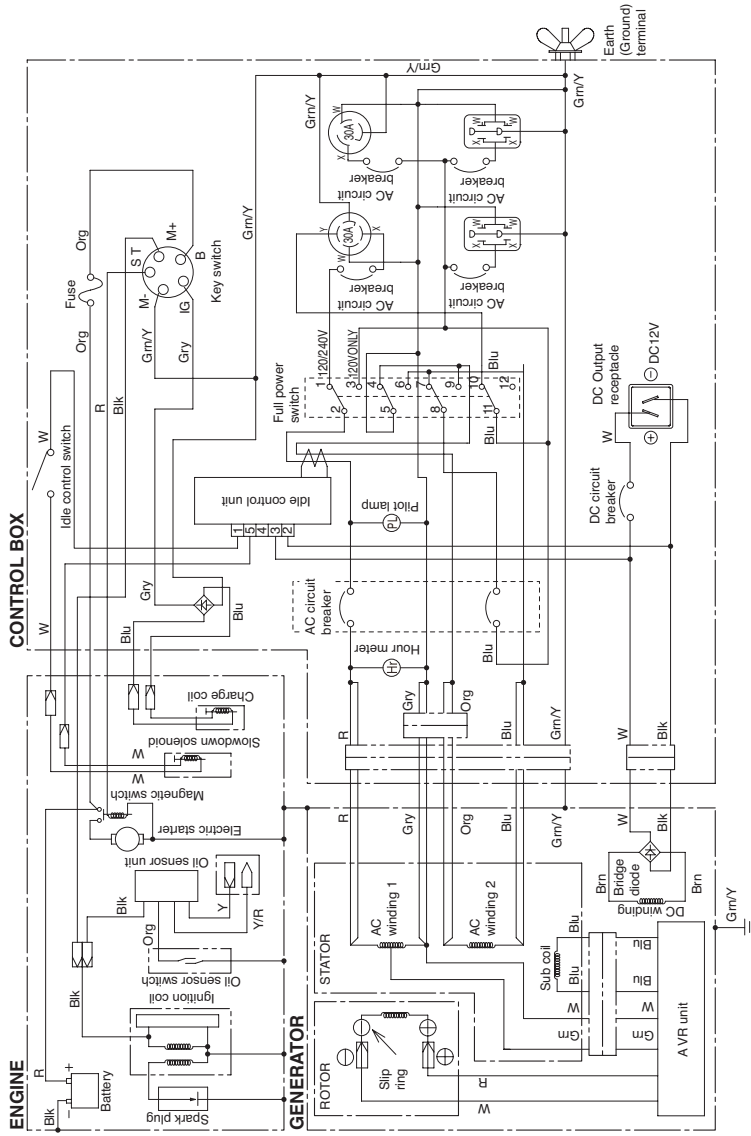

Wiring color code

- Y : Yellow
- Blk : Black
- Blk/W : Black/White
- Blu : Blue
- LBlu : Light blue
- Brn : Brown
- Brn/W : Brown/White
- Gm : Green
- Gm/W : Green/White
- Org : Orange
- Org : Gray
- R : Red
- W : White
- Gm/Y : Green/Yellow
- Pur : Purple



ISSUE EMD-GU6809



FUJI HEAVY INDUSTRIES LTD.
INDUSTRIAL PRODUCTS COMPANY

4-410 ASAHI, KITAMOTO-SHI, SAITAMA, 364-8511, JAPAN
TEL:+81-48-593-7798, FAX:+81-48-593-7946
<http://www.subaru-robin.jp>

PRINTED IN JAPAN
September 2009

IMPRESO EN JAPÓN
Septiembre 2009