

# Owner's Manual

# CRAFTSMAN<sup>®</sup>

## ELECTRIC ASSIST KIT

(FOR 486.24535 SLEEVE HITCH)

Model No. 486.24545

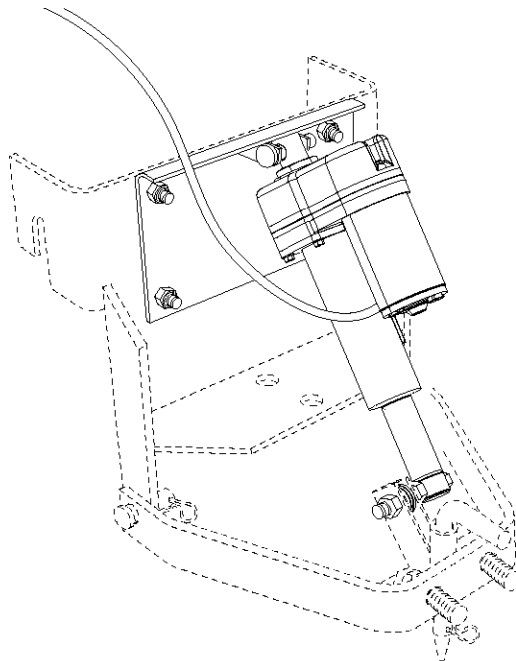

### CAUTION:

Before using this product, read this manual and follow all Safety Rules and Operating Instructions.

### IMPORTANT - READ THIS FIRST!!!

For Missing Parts or Assembly Questions

Please Call 866-576-8388

Mon.-Fri. 7 am - 5 pm CST.

FAX 217-728-2032 or e-mail [info@agri-fab.com](mailto:info@agri-fab.com)

Missing parts will be sent UPS in 24 hours directly to your home.

- Safety
- Assembly
- Operation
- Maintenance
- Parts

Sears, Roebuck and Co., Hoffman Estates, IL 60179 U.S.A.

[www.sears.com/craftsman](http://www.sears.com/craftsman)

PRINTED IN U.S.A.

FORM NO. 49234 (3/04)

## TABLE OF CONTENTS

SAFETY RULES .....	2	MAINTENANCE .....	6
FULL SIZE HARDWARE CHART .....	3	REPAIR PARTS ILLUSTRATION .....	7
CARTON CONTENTS .....	4	REPAIR PARTS LIST .....	7
ASSEMBLY .....	4	PARTS ORDERING/SERVICE .....	Back Page
OPERATION .....	6		

## WARRANTY

### LIMITED ONE YEAR WARRANTY ON ELECTRIC ASSIST KIT

For one year from the date of purchase, when this electric assist kit is maintained and lubricated according to the operating and maintenance instructions in the owner's manual, Sears will repair any defect in material or workmanship free of charge. If this electric assist kit is used for commercial or rental purposes, this warranty applies for only 90 days from the date of purchase.

This warranty does not cover repairs necessary because of operator negligence or abuse, including the failure to maintain the equipment according to instructions contained in the owner's manual.

WARRANTY SERVICE IS AVAILABLE BY CONTACTING THE NEAREST SEARS SERVICE CENTER/DEPARTMENT IN THE UNITED STATES.

This warranty applies only while this product is in the United States.

This warranty gives you specific legal rights, and you may also have other rights which vary from state to state. Sears, Roebuck and Co. D/817 WA. Hoffman Estates, Chicago, IL 60179



## SAFETY



Any power equipment can cause injury if operated improperly or if the user does not understand how to operate the equipment. Exercise caution at all times, when using power equipment.

- Read this owners manual and your vehicle and sleeve hitch owners manuals before using this electric assist kit with the sleeve hitch.
- Do not allow children to operate vehicle or sleeve hitch.
- Do not allow adults to operate the vehicle or sleeve hitch without proper instructions.
- Keep all nuts and bolts tight and be sure the equipment is in safe operating condition.



Look for this symbol to point out important safety precautions. It means--**Attention!! Become alert!! Your safety is involved.**

The model number and serial numbers will be found on a decal attached to the frame.

You should record both the serial number and the date of purchase and keep in a safe place for future reference.

MODEL NUMBER: 486.24545

SERIAL NUMBER: \_\_\_\_\_

DATE OF PURCHASE: \_\_\_\_\_

# HARDWARE PACKAGE CONTENTS

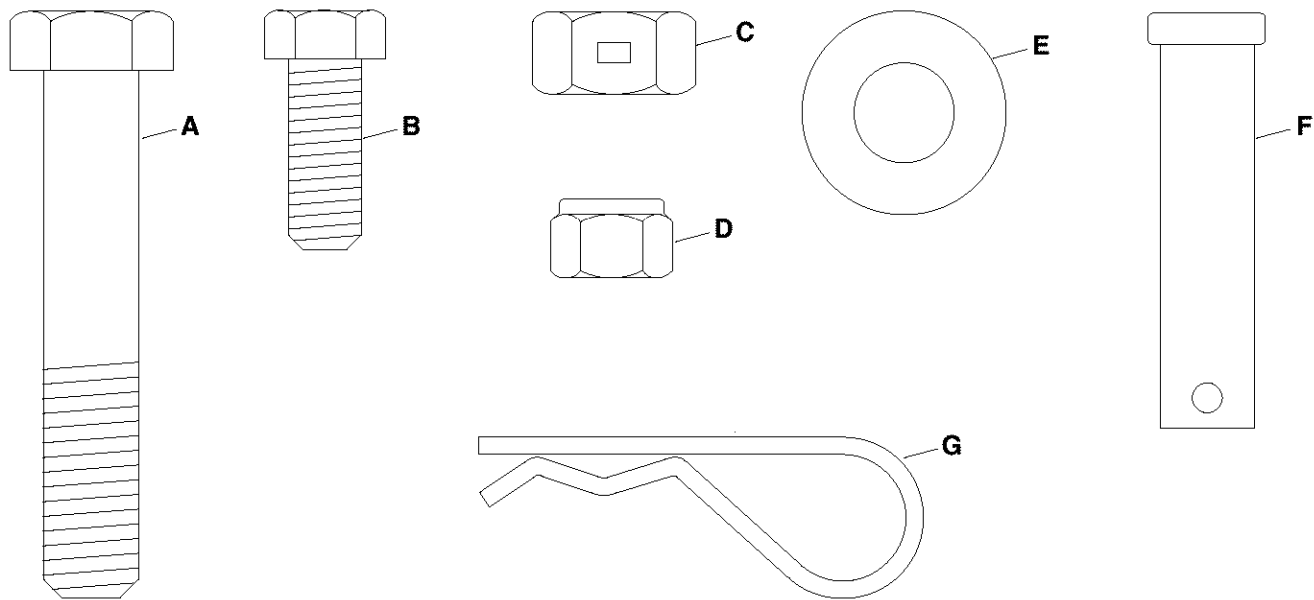

KEY	QTY.	DESCRIPTION	KEY	QTY.	DESCRIPTION
A	1	Hex Bolt, 1/2" x 2-3/4"	D	4	Hex Nylock Nut, 3/8"
B	4	Hex Bolt, 3/8" x 1"	E	5	Flat Washer, 1/2"
C	2	Hex Lock Nut, 1/2"	F	1	Clevis Pin, 1/2" x 2"
			G	1	Hair Cotter Pin, 3/32"

# ASSEMBLY

## CARTON CONTENTS

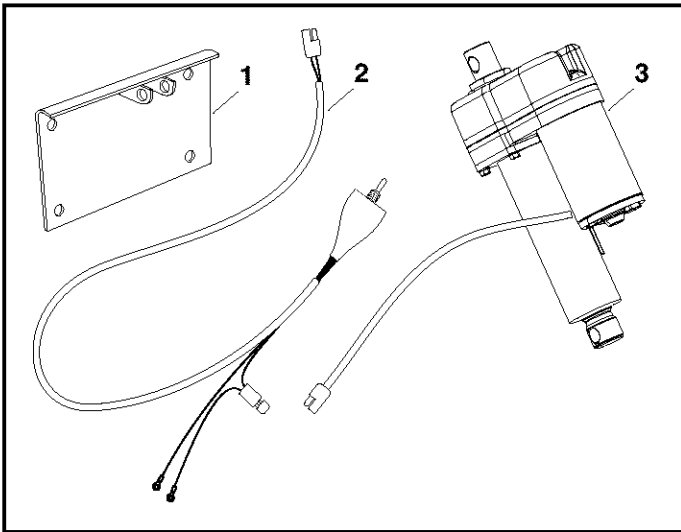

1. Mount Bracket Assembly
2. Switch with Wiring
3. Linear Actuator

## TOOLS REQUIRED FOR ASSEMBLY

- (2) 9/16" Wrenches or Adjustable Wrenches
- (2) 3/4" Wrenches or Adjustable Wrenches

## PREPARING THE SLEEVE HITCH

- Remove the bolt and nut that attach the lift link to the sleeve hitch frame. Remove the handle and the pivot brackets from the sleeve hitch frame. See figure 1.

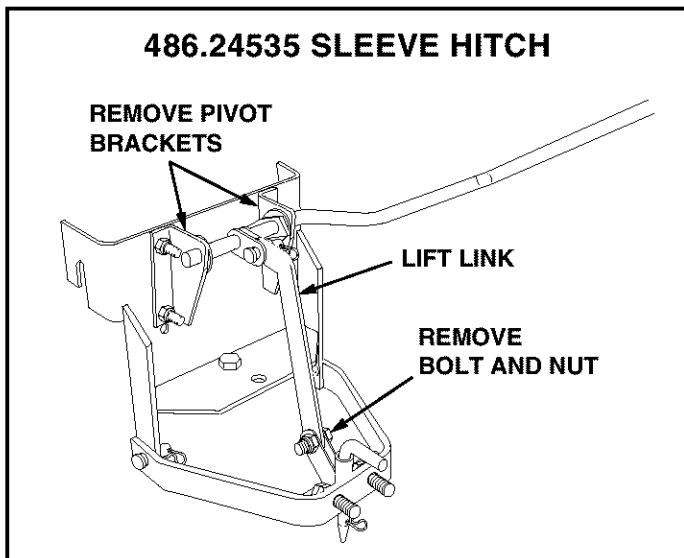

FIGURE 1

## ATTACHING THE ELECTRIC ASSIST KIT

- Attach the mount bracket assembly to the sleeve hitch frame using four 3/8" x 1" hex bolts and 3/8" nylock hex nuts. See figure 2.

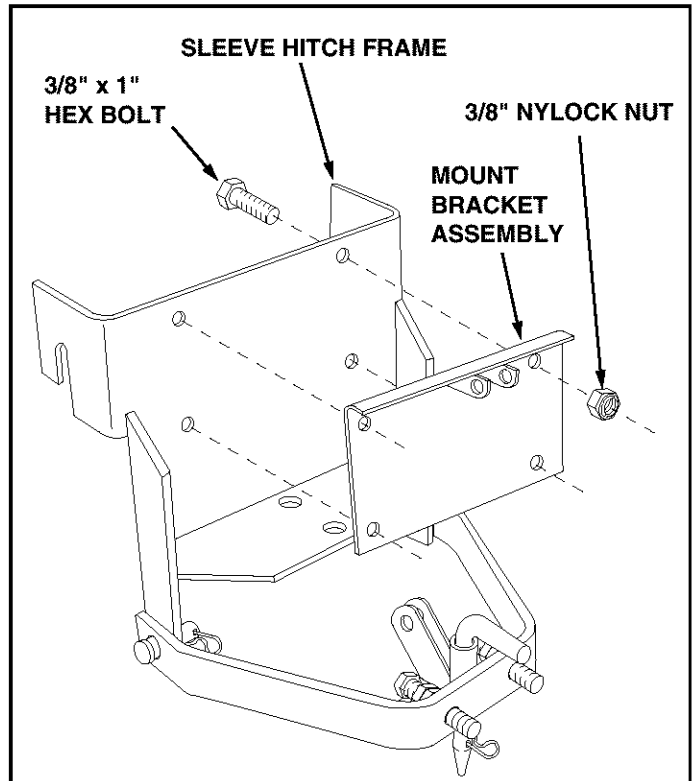
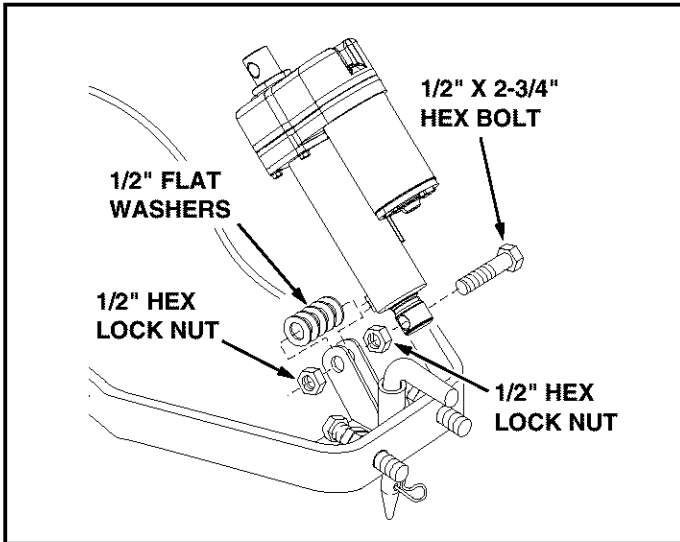

FIGURE 2

- Insert the 1/2" x 2-3/4" hex bolt into the lower shaft of the actuator and then screw a 1/2" hex lock nut as far as possible onto the bolt. See figure 3.
- Place up to five 1/2" flat washers between the anchor brackets on the lift assembly and insert the end of the 1/2" x 2-3/4" hex bolt through the anchor brackets and the washers. Screw a second 1/2" hex lock nut onto the bolt so that it is flush with the end of the bolt. Screw the first nut back against the anchor brackets and tighten both nuts securely. See figure 3.



**FIGURE 3**

- Place the other end of the actuator between the anchor brackets on the mount bracket assembly. Insert the 1/2" x 2" clevis pin through the anchor brackets, securing it with the 3/32" hair cotter pin. See figure 4.

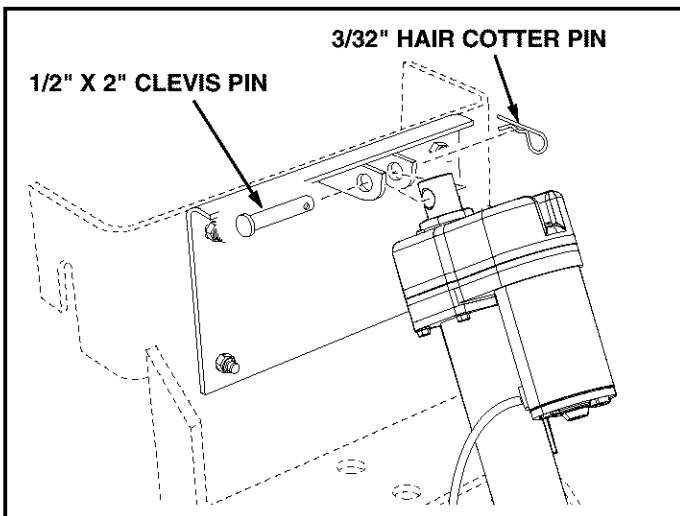

**FIGURE 4**

**IMPORTANT:** Connect to a 12 volt power source only.

- If you wish to permanently attach the switch to the tractor dash:
  - a. Drill a 1/2" hole in the lower right hand corner of the tractor's dash as shown in figure 5. A hole larger than 1/2" may cause the nuts on the switch to not hold properly.
  - b. Remove the hex nut from the actuator switch and then screw the round nut to about the mid-point on the threads.
  - c. Insert the switch into the hole you drilled in the tractor's dash and secure it with the hex nut you removed from the switch.
- To connect the switch to the tractor battery, attach the terminal on the red wire (with fuse) to the positive post and the terminal on the black wire to the negative post of the battery.
- Route the flexible conduit to the rear of the tractor avoiding hot engine parts, moving parts and pinch points. Connect the plug on the conduit wires to the plug on the actuator wires.

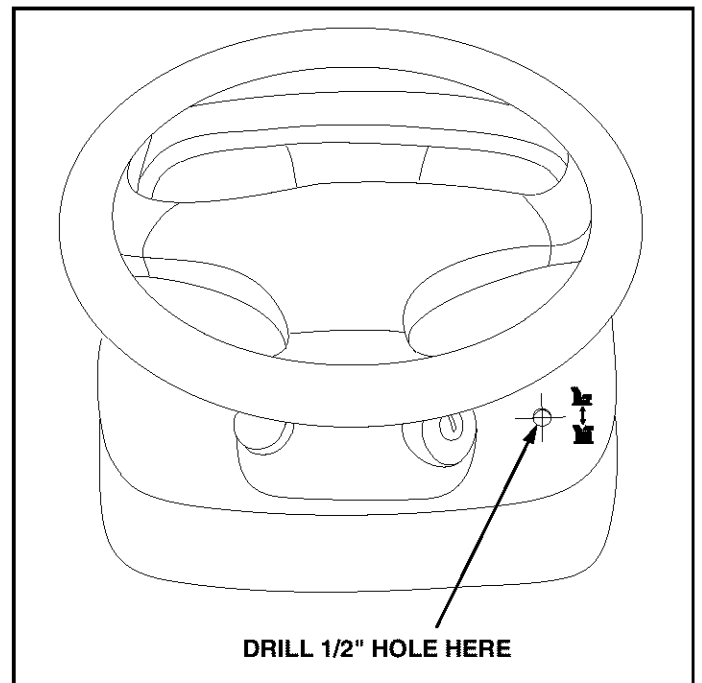

**FIGURE 5**

## OPERATION

- Keep clear of the linear actuator, the sleeve hitch and the attached implement when raising and lowering.
- The linear actuator is equipped with a safety clutch. When the actuator reaches the end of its stroke the clutch will slip and make a loud clicking sound.

## MAINTENANCE

- Clean off after each use.
- Store in a dry location.

# PARTS

## PARTS FOR MODEL 486.24545 ELECTRIC ASSIST KIT

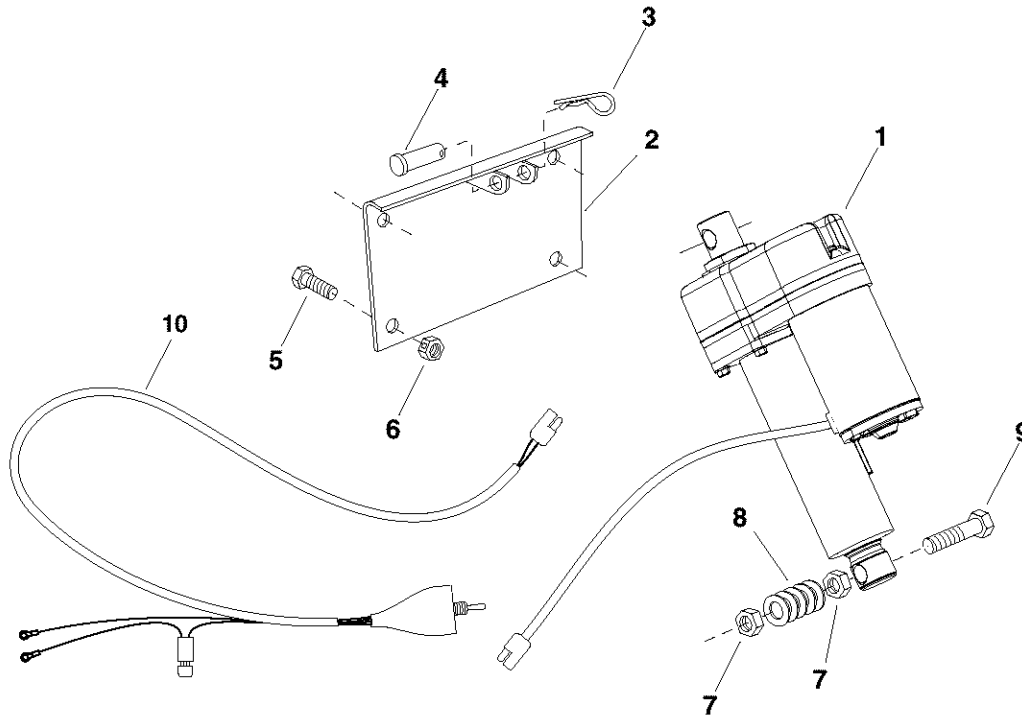

Ref	Part No.	Qty	Description	Ref	Part No.	Qty	Description
1	49235	1	Linear Actuator	6	43082	4	Hex Lock Nut, 3/8-16
2	64941	1	Mount Bracket Assembly	7	43262	2	Hex Lock Nut, 1/2-13
3	43343	1	Hair Cotter Pin, 3/32" X 2-5/16"	8	1540-59	5	Flat Washer
4	HA23505	1	Clevis Pin, 1/2" x 2"	9	23510	1	Hex Bolt, 1/2-13 x 2-3/4"
5	43001	4	Hex Bolt, 3/8-16 x 1"	10	49309	1	Switch with Fuse
					49234	1	Owner's Manual

# Get it fixed, at your home or ours!

For repair of major brand appliances **in your own home...**  
no matter who made it, no matter who sold it!

**1-800-4-MY-HOME<sup>SM</sup>** Anytime, day or night  
(1-800-469-4663)

[www.sears.com](http://www.sears.com)

To bring in products such as vacuums, lawn equipment and electronics  
for repair, call for the location of your nearest **Sears Parts & Repair Center.**

**1-800-488-1222** Anytime, day or night

[www.sears.com](http://www.sears.com)

For the replacement parts, accessories and owner's manuals  
that you need to do-it-yourself, call **Sears PartsDirect<sup>SM</sup>**!

**1-800-366-PART** 6 a.m. – 11 p.m. CST,  
(1-800-366-7278) 7 days a week

[www.sears.com/partsdirect](http://www.sears.com/partsdirect)

To purchase or inquire about a Sears Service Agreement:

**1-800-827-6655**

7 a.m. – 5 p.m. CST, Mon. – Sat.

Para pedir servicio de reparación a domicilio,  
y para ordenar piezas con entrega a domicilio:

**1-888-SU-HOGAR<sup>SM</sup>**  
(1-888-784-6427)

Au Canada pour service en français:

**1-877-LE-FOYER<sup>SM</sup>**  
(1-877-533-6937)

