

Husqvarna

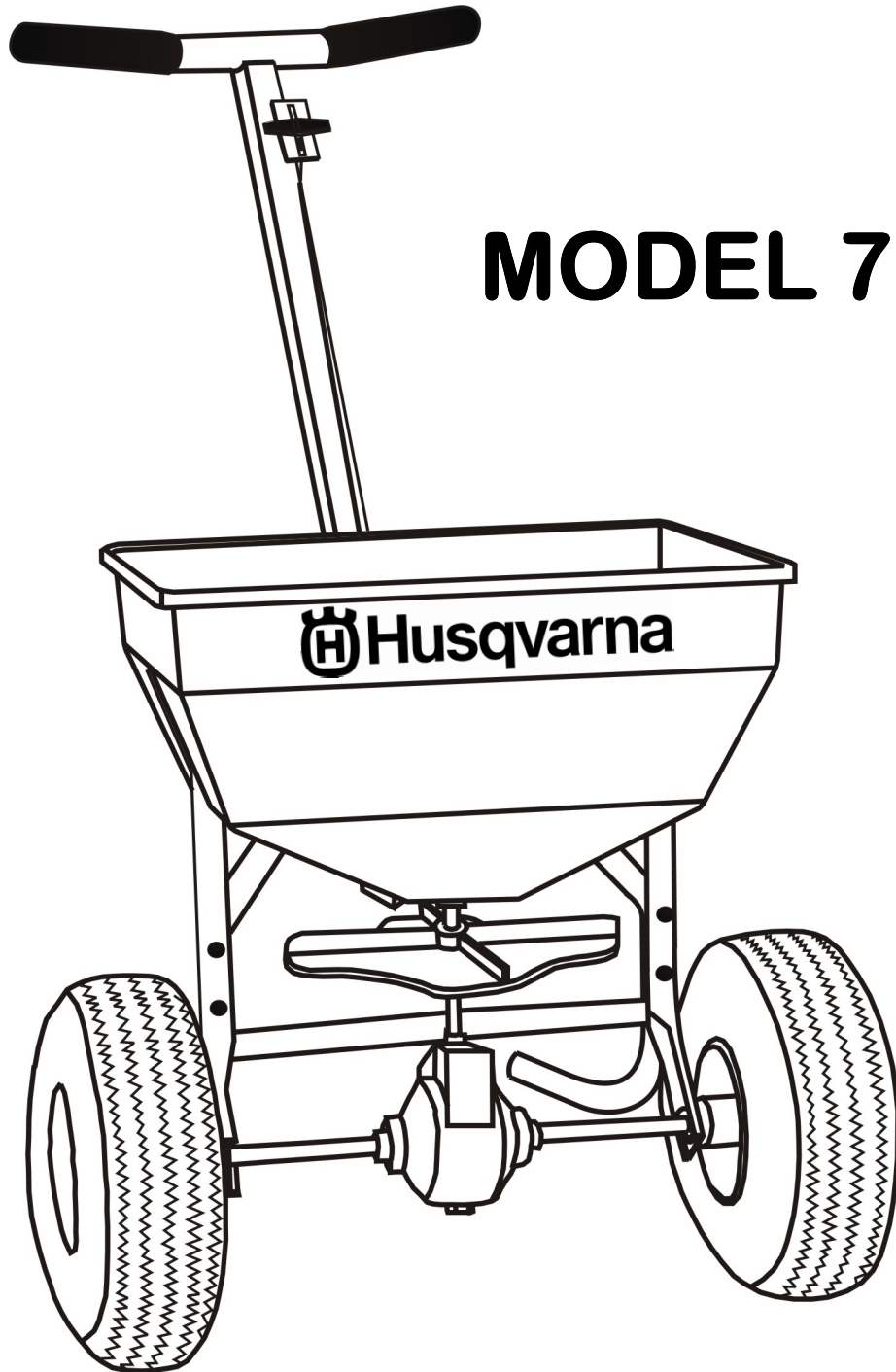

MODEL 70 LP

OWNER'S MANUAL

ASSEMBLY

1. Remove components from carton and place spreader upside down on a padded surface. Install LH. & RH. handle braces to frame as shown using four (4) 1/4-20 x 2 1/4" hex bolts and nuts but do not tighten.

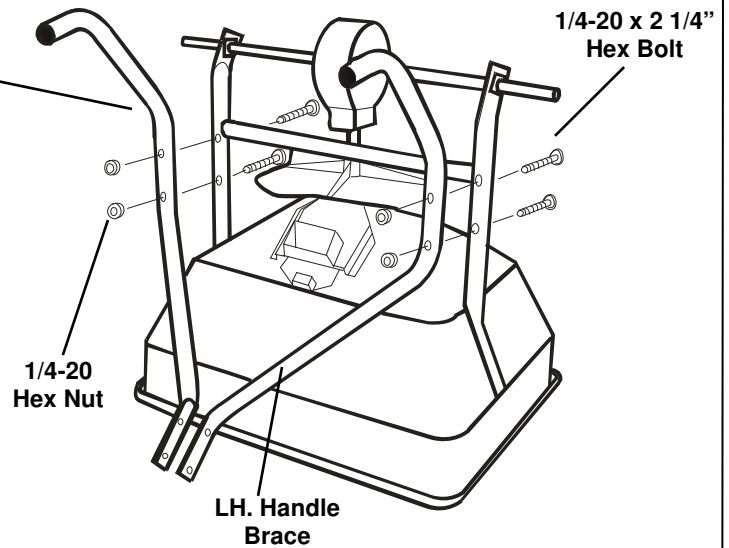
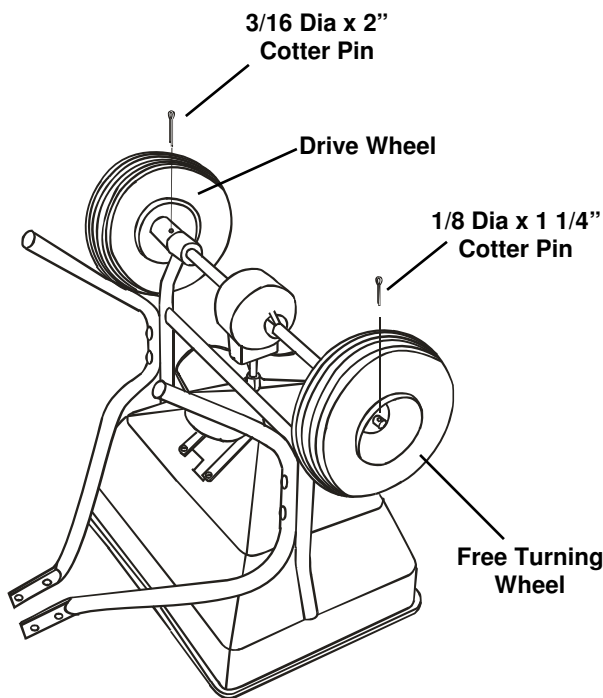

2. Slide wheels onto end of axle with the hub facing toward frame. Wheels are identical to ease assembly. Align the hole in the wheel hub and the hole in the axle as shown. Secure drive wheel to axle with 3/16 dia. x 2" cotter pin. Insert 1/8 dia. x 1 1/4" cotter pin in the hole near the end of axle to retain free turning wheel.

3. Turn spreader upright. For ease of assembly, make sure ON/OFF cable is on top of handle braces. With DOT on the handle assembly facing as shown, secure clamp bracket using a #10 x 3/4 slotted sheet metal screw. Install end of handle assembly between handle braces and secure with (2) 1/4-20 x 1 1/2" hex bolts and nuts.

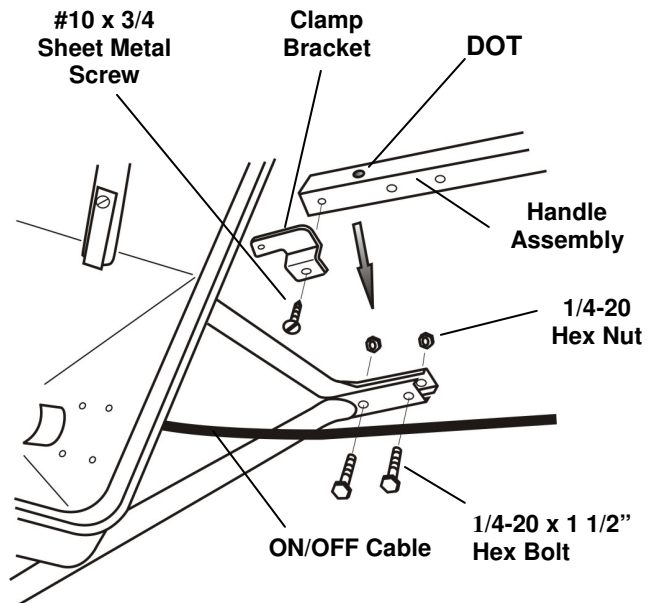

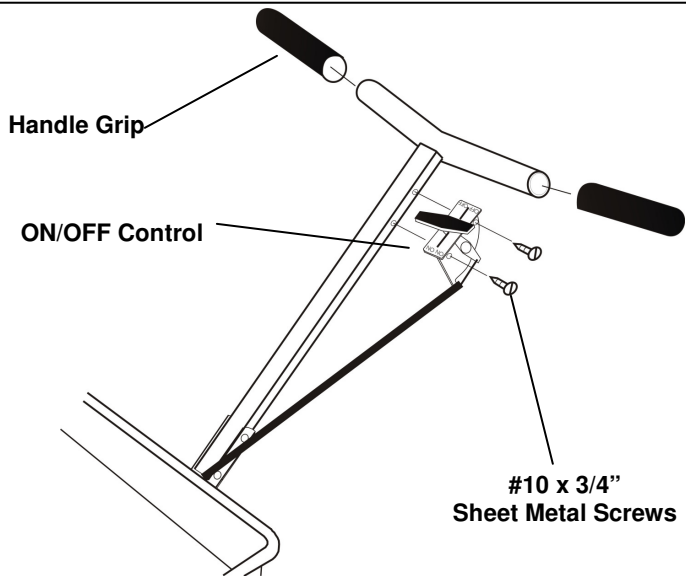

4. Attach ON/OFF control to the upper handle using (2) #10 x 3/4" slotted sheet metal screws. Slide handle grips onto the handle cross tube. Soapy water will ease installation. (Do not use petroleum based products).

5. Secure On/Off cable to the clamp bracket using the cable clamp and #10-24 x 5/8" screw and locknut as shown but do not tighten. Place On/Off control in the "ON" position and set the rate retting dial to the "WASH" position. Pull cable away from hopper sliding it in the cable clamp until the shut off plate stops against the rate setting dial. Tighten cable clamp securely. To check spreader for complete shutoff, pull the On/Off control lever back to the "OFF" position. Check to make sure hole in the hopper is completely closed. If not, loosen the cable clamp and slide the cable forward until the hole in hopper is closed. Re-tighten bolt and check shutoff.

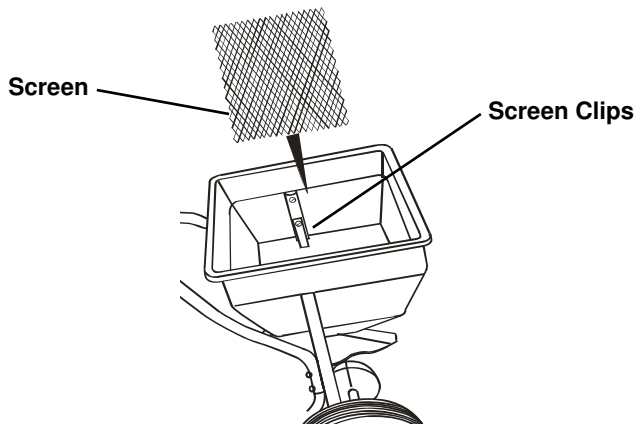
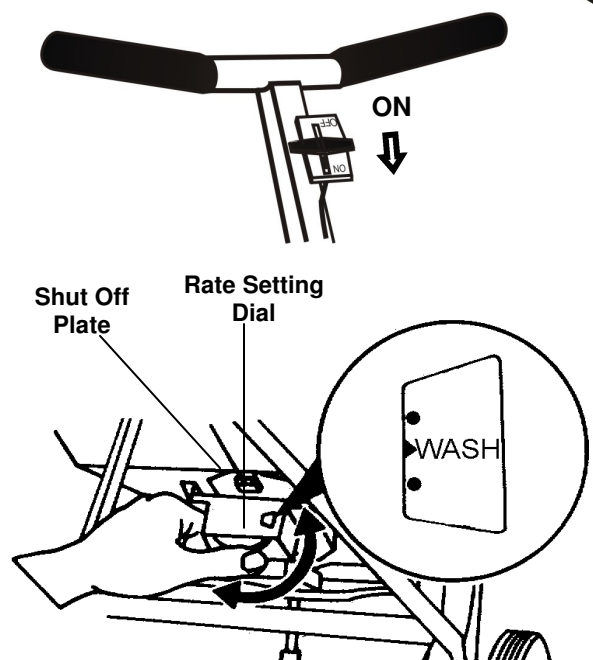
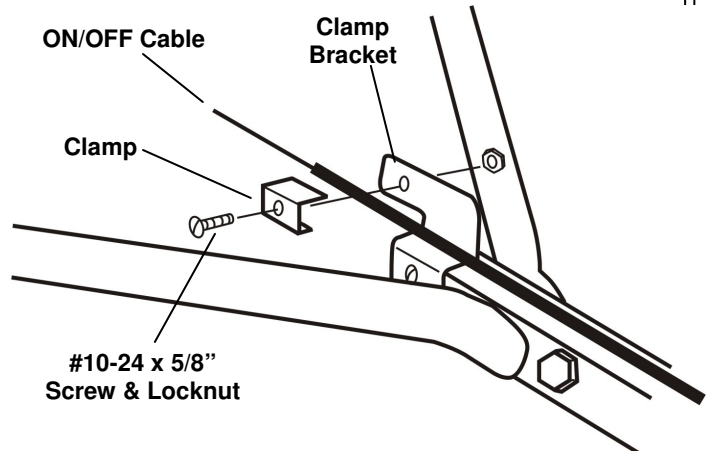

6. Insert screen into hopper by sliding it under the screen clips.

OPERATION

1. Check the product package for the rate setting, and recommended swath width. Turn the spreader off by pulling the lever to the "OFF" position as shown.

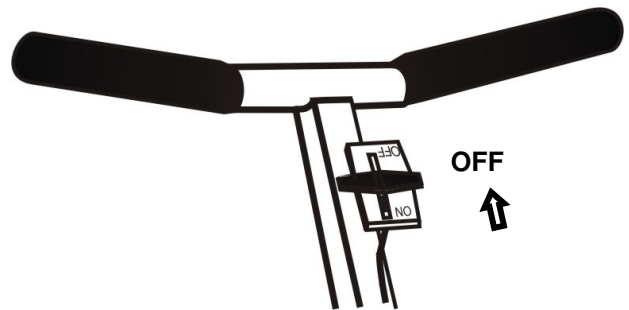

2. The rate setting is adjusted by rotating the rate cam to the desired setting. The rate cam locks at each setting.

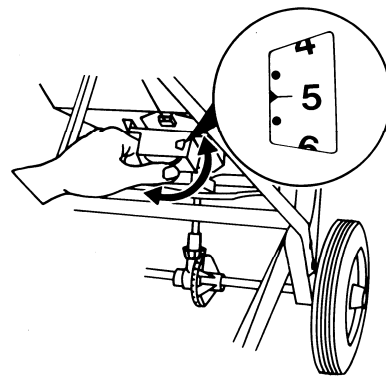

3. Always fill the spreader on the driveway or sidewalk-not on the lawn. Make sure spreader is in the "OFF" position. Empty after each use.

4. Start spreader moving, then open spreader by moving the lever to the "ON" position. Always push spreader, never pull. Pull the lever to the "OFF" position to close spreader.

5. Hold handle so top of spreader is level. Tipping the spreader too far can cause uneven spreading.

6. The settings and swath widths on the product label are recommended starting points. Always check the delivery rate and pattern on a small area before treating a large area. Actual delivery rate can vary due to weather conditions, operating variables, and condition of the product being applied. See "HOW TO DETERMINE SPREADER SETTING AND SWATH WIDTH" for details.

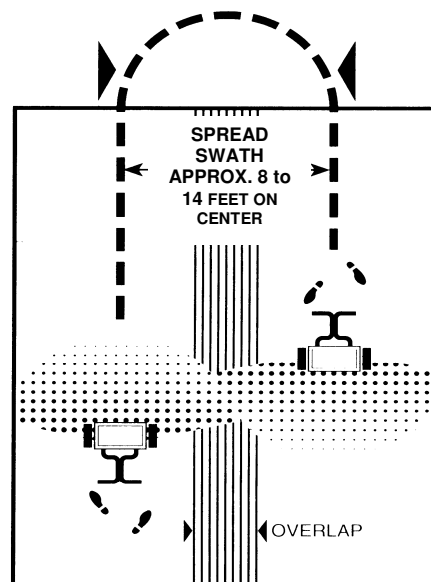

7. Push spreader 2 1/2 m.p.h. (18 feet in 5 seconds) for full 8' to 14' spread pattern when applying fertilizer products. Apply header strips at each end of area to be treated then space trips across the area as shown.

8. Empty spreader after each use. Return leftover material to its original container.

HOW TO DETERMINE SPREADER SETTINGS AND SPREAD WIDTH

Two major factors should be considered when determining correct spreader settings of any product:

1. The product application rate, or the amount of material applied per 1,000 square feet.
2. The effective pattern width, or the actual width in which material is applied. Label settings are a guide and can be affected by numerous factors.

EFFECTIVE PATTERN WIDTH

A simple visual pattern test can be made by operating the spreader over a non-turf area and evaluating the pattern. A more accurate method is to place a row of common, disposable, aluminum cake pans approximately 1 foot on centers. Set the rate cam at a middle setting and make 3 or 4 passes in the same direction as shown. Pour the material collected from each pan into individual bottles of the same size. Set them side by side in order, and visually inspect their volume. The effective pattern width is the distance out from the spreader to a point where the amount of material is 1/2 the average amount in the center pans. This distance is multiplied by 2 to achieve the total effective pattern width.

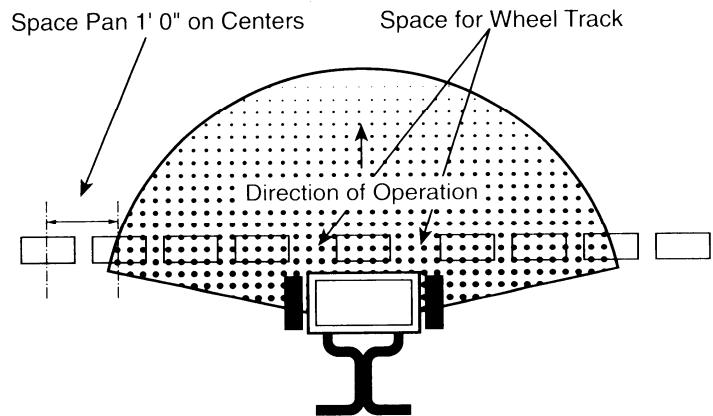

APPLICATION RATE

Knowing the effective pattern width (for example, 10 feet), measure a distance equal to 100 square feet (10' x 10' area covered). Determine the product coverage is pounds/ 100 sq. ft. by taking the weight of the product and dividing it by the recommended square foot coverage (add two zeroes to the weight of the bag).

EXAMPLE: Product weight: 25 lbs.
sq. ft. coverage: 5,000 sq. ft.
2500 lbs. - 5,000 sq. ft.
= .5 lbs. / 100 sq. ft.





Weigh out between 15 to 20 lbs. of material and spread over the 100 sq. ft. area. Weigh remaining material left in hopper and adjust rate setting as required. Repeat test until application rate is correct.

RATE SETTING CONVERSION

The following provides approximate  Husqvarna 70 LP settings for those units listed.

 Husqvarna 70 LP Setting	2	3	4	5	6	7	8	9	10	11	12	13	14	15	16	17	18	
	Prizelawn BF-1 /SS,HVO, CBRIII, Setting	G	H	J	K	M	N	N1/2	O	P1/2	Q	R	S	T	U	V	X	Z
	Lesco Hi-WHEEL Setting	E	F	G	H	I	J	K	L	—	—	M	N	O	—	P	R	S
	Scott Speedy Green Setting	—	—	2	—	3	—	4	—	5	—	6	—	7	—	8	—	—
	Scotts R8A/SR-1, AP&SR2000 Setting	I	J	L	M	O	P	—	Q	—	S	T	U	—	V	W	X	Z

The following provides approximate  Husqvarna 70 LP settings when only the product weight, square foot coverage, and visual inspection of the material is available.

FERTILIZER PARTICLE SIZE	BAG RATE Pounds of fertilizer used per 1,000 sq. ft. of coverage	APPROX. SETTING	APPROX. SPREAD WIDTH
Large, heavy particles 	5	6	12 FT.
	10	9	12 FT.
	15	11	12 FT.
Medium- mixed particles 	5	5	10 FT.
	10	7	10 FT.
	15	9	10 FT.
Small particles (nitrogen) 	1	2	10 FT.
	2	4	10 FT.
	3	5	10 FT.
Mixed size particles -some fines 	5	6	8 FT.
	10	9	8 FT.
	15	11	8 FT.
Light weight particles 	5	4	6 FT.
	10	5	To
	15	6	8 FT.

The conversions should be used as guidelines for establishing proper rate settings for the particular product being applied. Steps for obtaining the most accurate settings are outlined in the "How to Determine Spreader Settings and Spread Width" section of this manual.

These settings are approximate and may vary due to physical characteristics of the product. Walking speed, wear, condition of the turf and humidity, may cause actual rate setting to deviate. No expressed nor implied warranty or guarantee is provided as to coverage or uniformity indicated by these rate settings.

MAINTENANCE

1. Never store unused material in spreader. Return unused product to its original container.
2. Open and wash spreader thoroughly after each use and dry completely in sun or heated area.
3. Oil the axle bearings, impeller shaft bearing in hopper.
4. Remove gear cover and wash gears thoroughly. Oil all bearing areas and face of gear teeth. Re-install gear cover.
5. Gear mesh should be checked on a regular basis during high use periods. Clearance between the axle gear and pinion gear should be minimal but not tight. If adjustment is necessary, loosen axle collar set screw and hold gears together. Slide axle collar against the gear support and tighten axle collar set screw. Spin drive wheel. Gears should run freely and smoothly.
6. Impeller surface should be cleaned periodically to remove build-up of product. Build-up can cause the spread pattern to change.
7. Tire pressure should be 20-25 PSI.

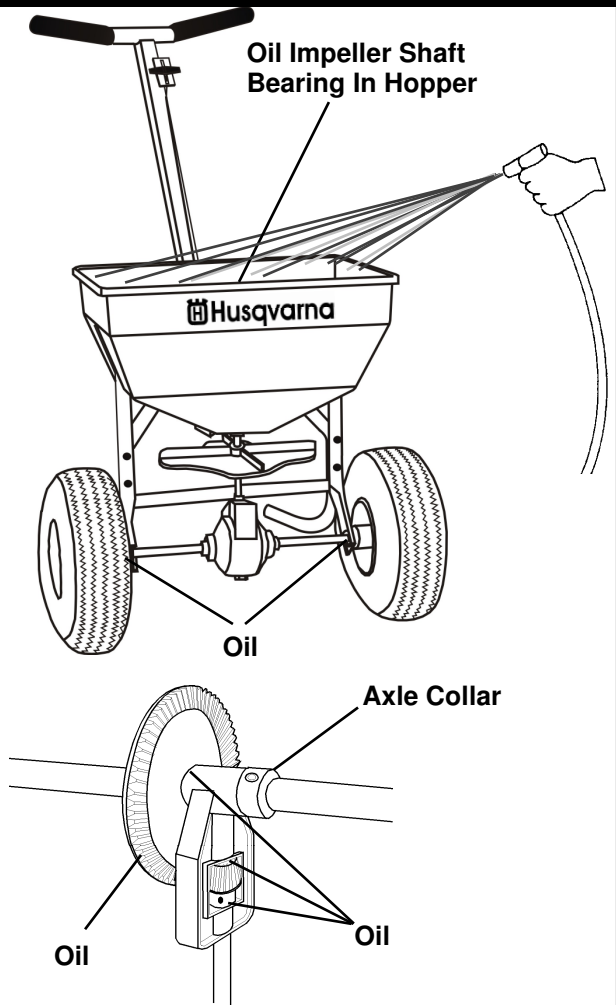

NOTES

Parts List Model 70 LP

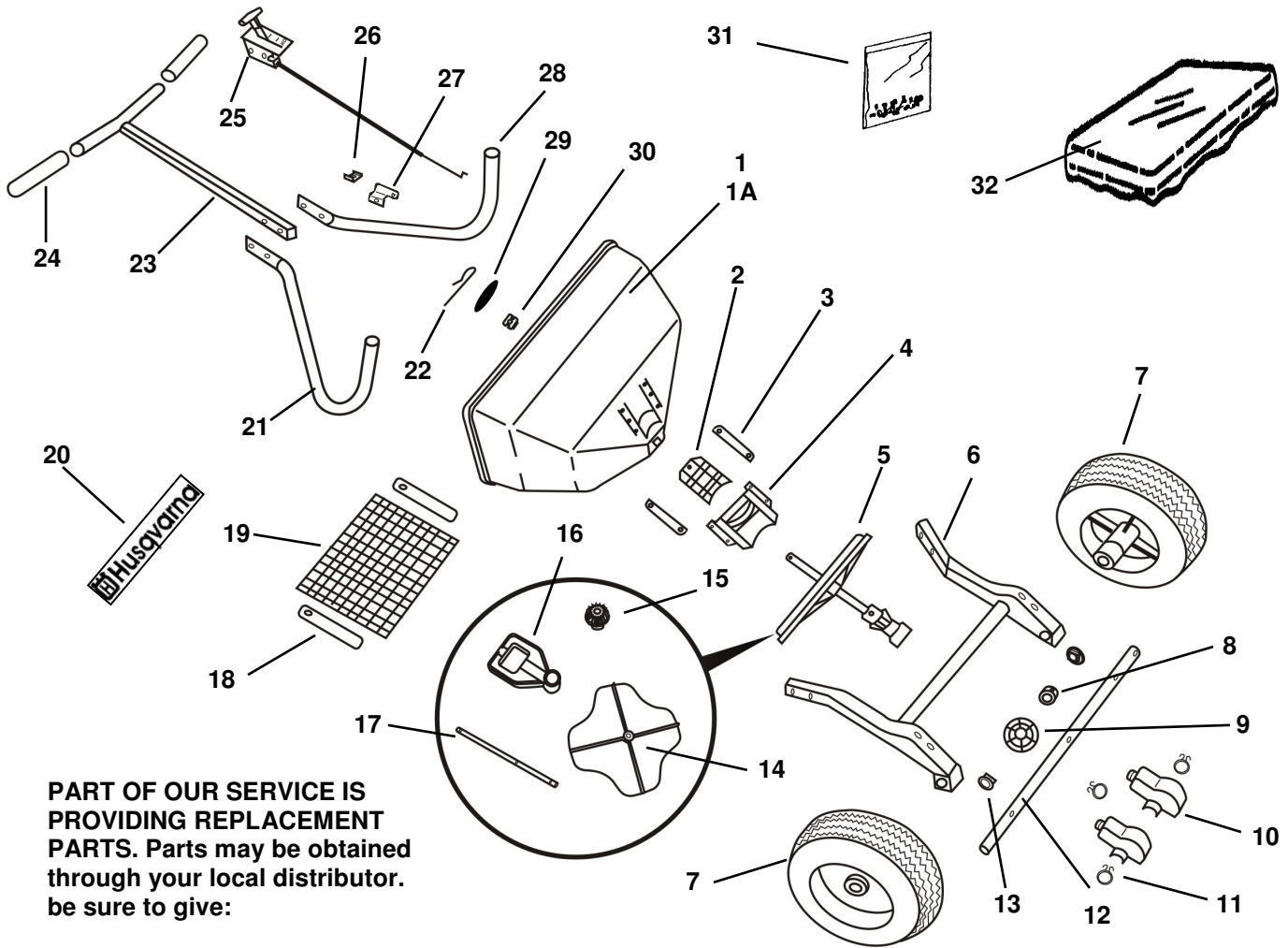

PART OF OUR SERVICE IS PROVIDING REPLACEMENT PARTS. Parts may be obtained through your local distributor. be sure to give:

1. SPREADER MODEL NUMBER
2. SPREADER NAME
3. PART NUMBER
4. NAME OF PART AS SHOWN

Husqvarna

7349 Statesville Road
Charlotte, NC. 28269
(800) 448-7543

Key	Description	Part No.	Key No.	Description	Part No.
1	Hopper Assembly	525 56 82-06	17	Impeller Shaft	525 56 87-06
1A	Hopper *	525 56 82-07	18	Screen Clip (2 Req.)	525 56 91-02
2	Shutoff Plate *	525 56 84-03	19	Hopper Screen	525 56 82-08
3	Shutoff Plate Guides (Set)*	525 56 84-04	20	Hopper Label *	525 56 82-08
4	Rate Cam & Chute Assembly *	525 56 83-03	21	Handle Brace W/ Plug- LH.	525 56 85-05
5	Impeller Assembly	525 56 87-05	22	Agitator	525 57 00-01
6	Frame Assembly	525 556 92-02	23	Upper Handle Assembly	525 56 85-07
7	Drive & Free Turning Wheel	525 56 96-02	24	Handle Grip (2 Req.)	525 56 85-08
8	Axle Collar	525 56 86-06	25	On/Off Control	525 56 93-02
9	Axle Gear	525 56 86-05	26	Cable Clamp	525 56 90-01
10	Gear Cover Assembly (2 Req.)	525 56 88-05	27	Bracket-Cable Clamp	525 56 90-02
11	Gear Cover Clamp (3 Req.)	525 56 88-06	28	Handle Brace W/ Plug- RH.	525 56 85-06
12	Axle	525 56 86-07	29	Hopper Plug*	525 56 82-11
13	Axle Bushing (2 Req.)	525 56 86-08	30	Impeller Shaft Bearing *	525 56 87-07
14	Impeller	525 56 87-01	31	Fastener/Parts Package	525 56 94-02
15	Pinion Gear	525 56 88-07	32	Hopper Cover	525 56 82-09
16	Gear Support	525 56 88-08			

* Parts included in Hopper Assembly