

Parts Manual for

SNAPPER

21" SERIES 6 *

BLADE BRAKE CLUTCH

WALK MOWERS



*NOTE: See parts manual:

#06131 for 21" Series 2 & 4 (BBC) models

#06051 for 21" Series 7 models

#06041 for 21" Series 1 & 5 models

#06142 for 21" Series 7 Commercial models

#06141 for 21" Series 0 Commercial models

NOTE: THE SERIES NUMBER IS THE
LAST NUMBER IN THE FIVE DIGIT
MODEL DESIGNATION.

INDEX - GROUP	(SECTION)	PAGE(S)
HANDLES, CONTROLS	(ONE)	1.1 - 1.3
SIDE CHUTES, GRASS CATCHERS	(TWO)	2.1
CUTTING DECK, BLADES	(THREE)	3.1 - 3.2
DRIVE SYSTEM - SELF PROPELLED	(FOUR)	4.1 - 4.4
WHEELS, BRACKETS, LATCHES	(FIVE)	5.1 - 5.5
ACCESSORIES **	(SIX)	6.1 - 6.3
DECALS	(SIX)	6.2
ELECTRIC START SYSTEM	(SEVEN)	7.1

** PAC-N-SAC ACCESSORY COVERED IN PARTS MANUAL 06121

SNAPPER POWER EQUIPMENT

McDonough, GA • 30253



(REV. 1, 2/91)
(REPLACES I.R. 9/89)

MANUAL #06132

HANDLES & CONTROLS

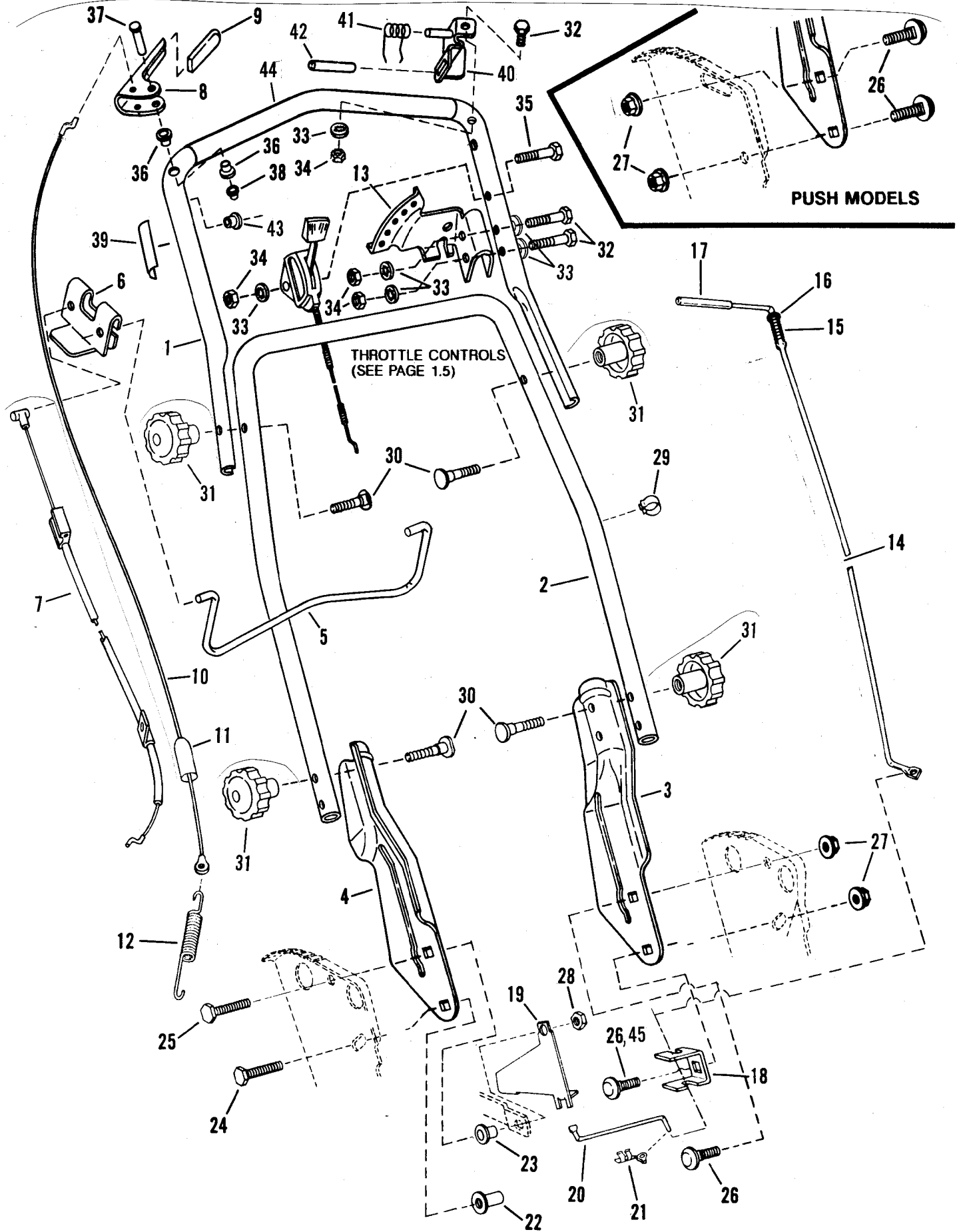

ITEM	PART NO.	DESCRIPTION	(USED ON)
1	3-6357	HANDLE, Upper	Self-propelled
-	3-6203	HANDLE, Upper	Push
2	3-6350	HANDLE, Middle	All
3	3-8467	HANDLE, Lower Left Hand	All
4	3-8466	HANDLE, Lower Right Hand	All
5	1-9762	CONTROL, Blade	All
6	3-2445	CLIP, Blade Control	All
7	1-9255	CABLE, Blade Control	All
8	3-2826	HANDLE, Wheel Drive	Self-propelled
9	1-4307	GRIP, Wheel Drive Handle	Self-propelled
10	2-3134	CABLE, Clutch Pull (Z-BEND)	All (Incl. Item 11)
11	1-2121	COVER, Vinyl	Self-propelled (Part of Item 10)
12	1-2122	SPRING, Clutch	Self-propelled
13	3-8478	SECTOR, Speed	Self-propelled
14	2-3795	LEVER, Speed Control	Self-propelled
15	1-2093	SPRING, Speed Control	Self-propelled
16	9-0188	WASHER, 3/8 Flat	All-different locations
17	2-3801	GRIP, Speed Control Handle	Self-propelled
18	3-2830	ANCHOR, Speed Control	Self-propelled
19	3-2408	GUIDE, Lower V-Belt	Self-propelled
20	2-3790	ROD, Transfer	Self-propelled
21	1-0937	CLIP, Transfer Rod	Self-propelled
22	9-0895	TEE-NUT, 5/16-18	Self-propelled
23	1-2114	BUSHING, Differential	Self-propelled
24	9-0595	BOLT, 5/16-18x3/4 Flange Lock	Self-propelled
25	9-0238	CAPSCREW, 5/16-24x1	Self-propelled
26	9-1026	BOLT, 5/16-18x5/8 Carriage	All (different locations)
27	9-0585	NUT, 5/16-18 Hex Flange Lock	All (different locations)
28	9-0222	NUT, 5/16-24 Center Lock	Self-propelled
29	2-3813	CLIP Cable/Wiring	All
30	9-1013	SCREW, 5/16-18x1-7/8 Curved Head	All
31	2-3735	KNOB, 5/16-18	All
32	9-1025	CAPSCREW, 1/4-28x1-3/8	Self-propelled
33	9-1023	LOCKWASHER, 1/4 Internal Tooth	All (different locations)
34	9-1024	NUT, 1/4-20 Hex	All (different locations)
35	9-1022	CAPSCREW, 1/4-28x1-3/4	All (throttle control)
36	1-4343	BUSHING	All
37	2-3792	PIN, Clutch Handle	Self-propelled
38	9-1020	PUSH-NUT (for handle pin)	Self-propelled
39	2-3746	DECAL, Blade Control	All (see backpage)
40	5-1904	ASSEMBLY, Blade Control Bracket	All
41	1-5108	SPRING, Blade Control	All
42	1-4946	GRIP, Pivot	All
43	1-5092	BUSHING	All
44	2-3902	GRIP, Foam	All
45	9-1077	BOLT, 5/16-18x5/8" Carriage	Self-propelled

THROTTLE CONTROLS

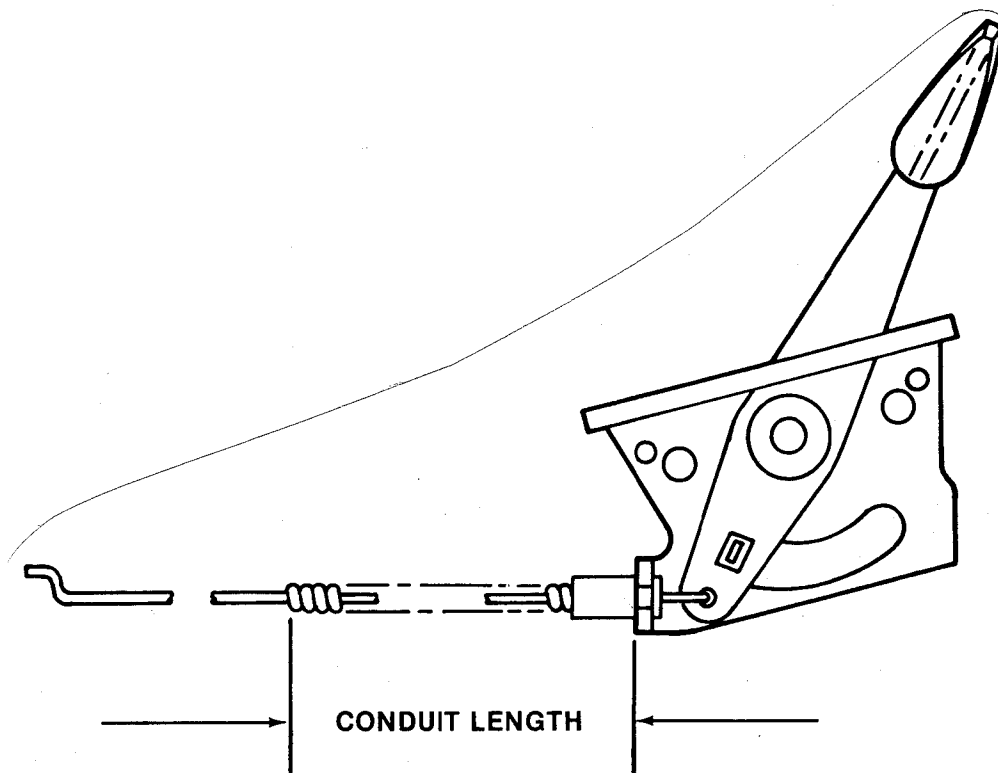

THROTTLE CONTROLS SERIES 6 '90 MODELS

ENGINE/MODEL	(CYCLE)	PART NO.	CONDUIT LENGTH
BRIGGS	(4)	1-9254	45.0"
TECUMSEH	(4)	2-3829	62.0"

'91 MODELS

ENGINE/MODEL	(CYCLE)	PART NO.	CONDUIT LENGTH
BRIGGS	(4)	1-6565	58.0"
TECUMSEH	(2)	1-6706	62.0"

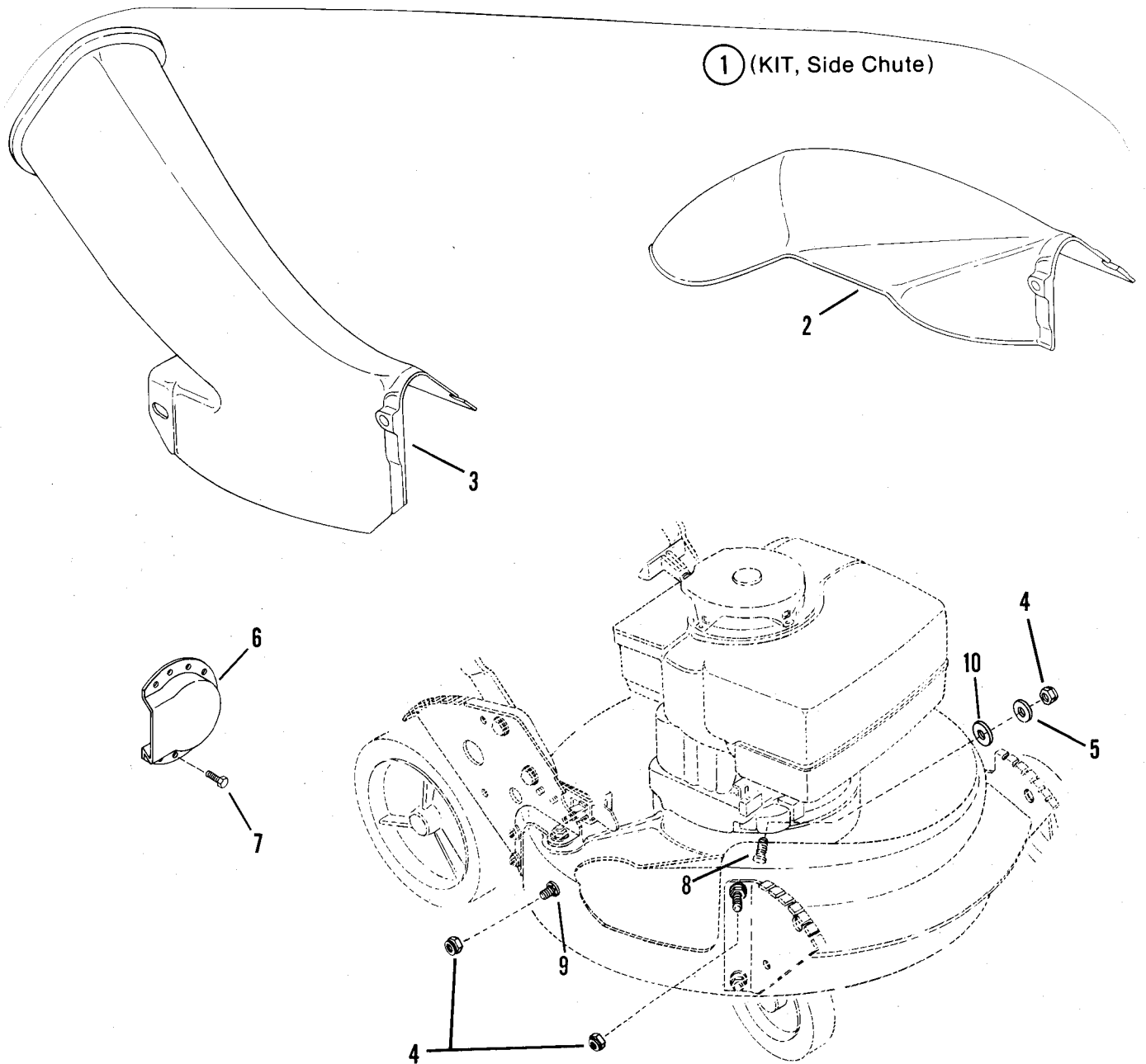

ITEM	PART NO.	DESCRIPTION
1	6-0955	KIT, Side Chute (Includes Item 2)
2	1-6090	CHUTE, Side
3	1-6050	ADAPTER, Grass Bag Deck
4	9-0951	NUT, 5/16-18 Hex Lock Flange Lock (3)
5	9-0188	WASHER, 5/16 Flat
*6	2-3152	DEFLECTOR, Muffler
*7	2-3023	SCREW, #8-18x3/8" Hex Head Cap (3)
-	6-0935	GRASS CATCHER (See page 6.2)
8	9-1097	BOLT, 5/16-18x3/4" Carriage
9	1-1791	RETAINER, 5/16 Bolt
10	9-0122	WASHER, 5/16 Flat

***BRIGGS & STRATTON ONLY**

CUTTING DECK, BLADE, INTERLOCK

REAR WHEEL BRACKETS

See Pages 5.1-5.2.

DECK BRACKET
See Pages 4.1-4.2

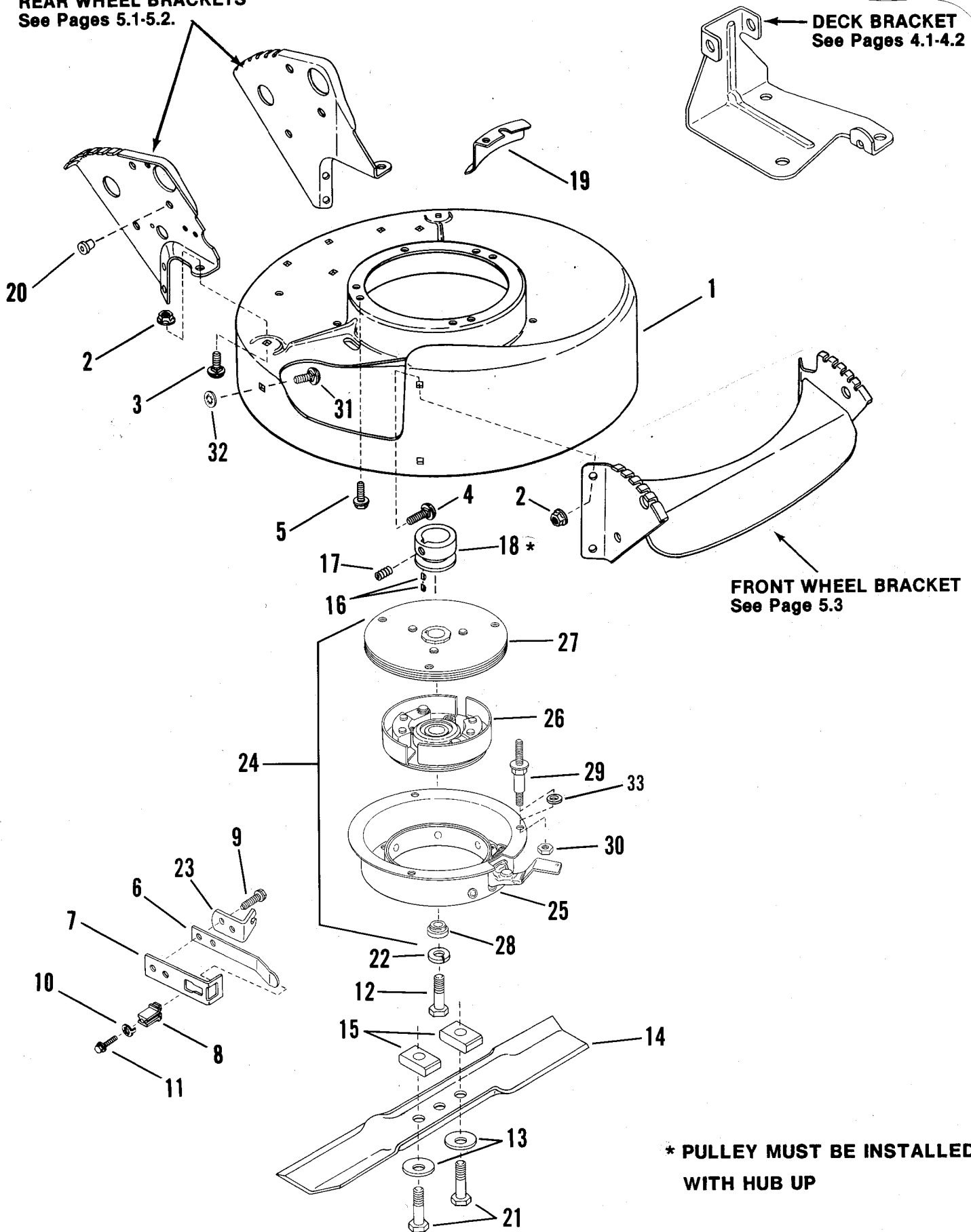

* PULLEY MUST BE INSTALLED WITH HUB UP

ITEM	PART NO.	DESCRIPTION
1	5-1598	DECK, Mower (Includes painted Deck with decals)
2	9-0585	NUT, Hex Flanged Lock (10)
3	9-0731	BOLT, 5/16-18x1/2" Short Neck Carriage Gr. 5 (9)
4	9-0383	BOLT, 5/16-18x1" Short Neck Carriage (4)
5	9-0324	SCREW, 3/8-16x1" Hex Head Self-tapping (Engine Mounting) (3)
6	3-2417	SPRING, Wheel Bracket Type Interlock
7	3-2416	BRACKET, Wheel Bracket Type Interlock
8	1-2048	INSULATOR, Interlock
9	9-0539	SCREW, 1/4-20x1/2" Hex Self-tapping (2)
10	9-0385	WASHER, No. 8 TAB Int. Tooth Lock
11	9-0379	SCREW, No. 8-18x3/4" Hex Head Machine
12	9-0167	SCREW, 3/8-24x2.0" Hex Head Cap
13	1-2063	WASHER, Cone (2)
14	1-9795	BLADE, Cutter
15	3-2175	SPACER, Blade (2)
16	1-0783	KEY, Hi-Pro ('90 Models)
-	1-5894	KEY, Woodruff (2) (Briggs)
-	1-6755	KEY, Square ('91 Models & Later)(Tec. 2-CY.)
17	9-0201	SCREW, 5/16-18x5/16" Hex Socket Set
18	1-5780	PULLEY, Engine (Propelled Models Only) (25mm I.D.x2-1/8" O.D.)
-	2-2106	PULLEY, Engine (Tec. 2-CY.) (25mm I.D.x2-1/8" O.D.)
19	3-1968	SHIELD, Cover, Belt Opening (Push Models Only)
20	1-2135	BUSHING, Interlock Wire
21	9-0503	SCREW, 3/8-16x1-3/4" Hex Head Cap (2)
22	9-0118	WASHER, 3/8 Split Lock
23	3-2421	BRACKET, CABLE - BBC
24	5-2421	ASSEMBLY, Blade Clutch (Includes items 25 thru 28)
25	1-6582	ASSEMBLY, Bowl & Brake
26	1-4178	ASSEMBLY, Clutch Bearing
27	1-9230	ASSEMBLY, Flywheel
28	1-4176	WASHER, Blade
29	1-5095	STAND-OFF (3)
30	9-0613	NUT, 3/8-16 Hex Flange Lock (3)
31	9-0799	BOLT, 5/16-18x1" Short Neck Carriage (3)
32	1-1791	RETAINER, 5/16 Bolt (3)
33	1-2316	WASHER, 3/8 Flat (3)

DRIVE SYSTEM - SELF-PROPELLED

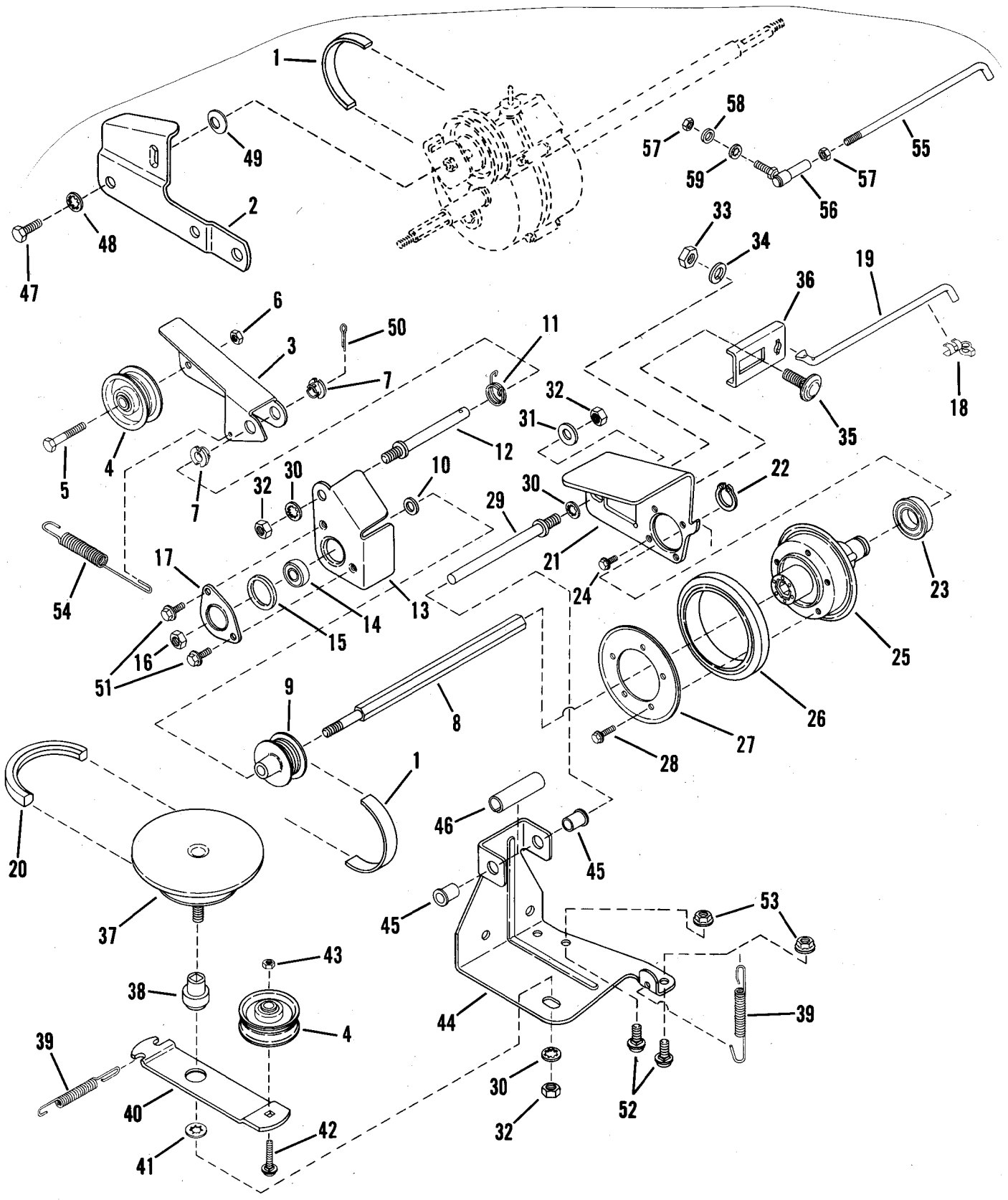

ITEM	PART NO.	DESCRIPTION
1	1-2354	BELT, Poly-Vee
2	3-1880	LINK, Differential
-	5-1921	ASSEMBLY, Clutch Idler (Includes items 3 thru 7)
3	3-2832	ARM, Clutch Idler
4	1-2124	PULLEY, Idler
5	9-0552	CAPSCREW, 1/4-28x1-3/8" Hex Head
6	9-0303	NUT, 1/4-28 Hex Lock
7	1-2117	BUSHING, 3/8 I.D. Nylon (2)
8	2-3744	HEX-SHAFT
9	1-7736	PULLEY
10	1-2316	WASHER
11	1-2126	SPRING, Torsion
12	1-2111	STUD
13	3-1873	HOLDER, Bearing (Inner Half)
14	1-2304	BEARING, Ball
15	1-1025	O-RING
16	9-0289	NUT, 3/8 Hex Center Lock
17	3-1809	HOLDER, Bearing (Outer Half)
18	1-0937	CLIP, 1/4 Right Arc (Transfer Rod)
19	2-3790	ROD, Transfer
20	1-2353	BELT, Engine Drive
-	5-7444	ASSEMBLY, Driven Disc (Includes items 21 thru 28)
21	3-8486	PLATE, Thrust
22	1-0746	RING, Retaining
23	1-5474	BEARING, Ball
24	9-0981	SCREW, #10-32x1/4" Self-Tapping Machine (4)
25	5-1616	ASSEMBLY, Hub (Includes 1-1108 Bushing & Two #10x1/2" Screws)
26	2-3364	DRIVEN-RING
27	3-1013	PLATE, Ring Retaining
28	9-0913	SCREW, #10-24x1/2 Self-Tapping Machine (5)
29	1-2125	GUIDE, Thrust Plate
30	9-0390	WASHER, 3/8 Internal Tooth Lock (2)
31	9-0122	WASHER, 3/8 Flat (3)
32	9-0155	NUT, 3/8-24 Hex (3)
33	9-0196	NUT, 5/16-18 Hex
34	9-0187	WASHER, 5/16 Split Lock
35	9-0316	BOLT, 5/16-18x3/4 Carriage
36	3-2831	CONNECTOR, Transfer Rod
37	-	ASSEMBLY, Drive-Disc
38	-	BUSHING
39	1-7326	SPRING (Wheel Drive & Idler) (2)
40	3-2116	ARM, Idler
41	1-3847	RETAINER, 3/8 Bolt
42	9-0078	BOLT, 1/4-20x1-1/4" Carriage
43	9-0372	NUT, 1/4-20 Hex Center Lock
-	5-0751	ASSEMBLY, Deck Bracket (Includes items 44 thru 46)
44	3-1919	BRACKET, Deck
45	1-2306	BUSHING, Flange (2)
46	2-1758	SPACER
47	9-0534	SCREW, 5/16-18x1/2" Hex Head Cap
48	9-0391	WASHER, 5/16 Internal Tooth Lock
49	1-1079	WASHER, Spring
50	9-0555	COTTER-PIN, 3/32x1/2"
51	9-0539	SCREW, 1/4-20x1/2" Self-Tapping
52	9-0731	BOLT, 5/16-18x5/8" Short Neck Carriage (2)
53	9-0585	NUT, 5/16-18 Hex Flange Lock (2)
54	1-2122	SPRING, Clutch
**55	1-5752	LINK, Transfer
**56	1-5753	JOINT, Ball
**57	9-0095	NUT, 1/4-28 Hex
**58	9-0055	WASHER, 1/4 Flat
**59	9-0053	WASHER, 1/4 Internal Tooth Lock

****NOTE:** Used On Electric Start Models Only.

* NOTE: Order Kit #6-0710 for replacement.

TRANSMISSION (DIFFERENTIAL)

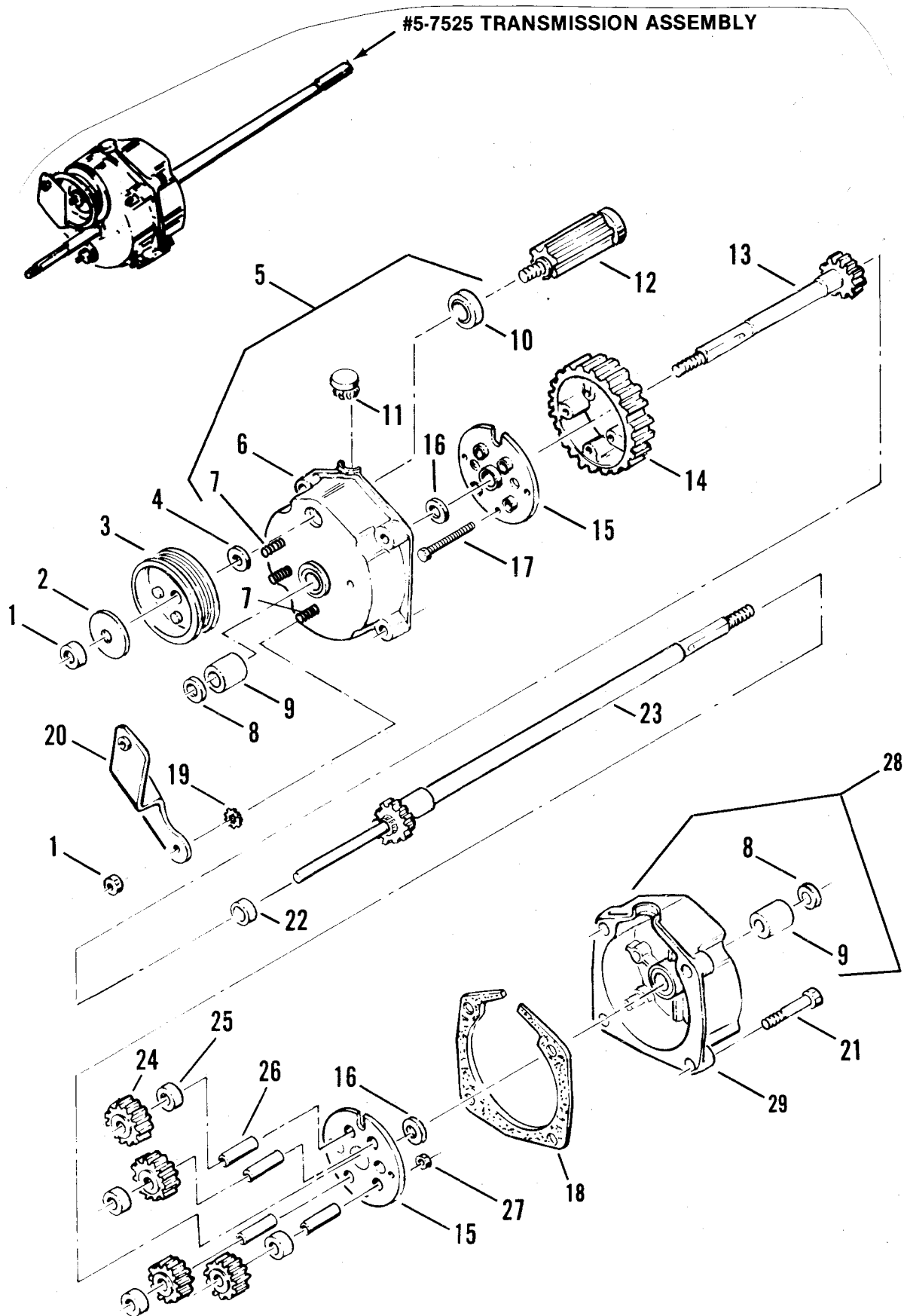

ITEM	PART NO.	DESCRIPTION
-	5-7525	ASSEMBLY, Transmission (Includes items 1 thru 29)
1	1-1201	LOCKNUT, 5/16-24 Hex (3)
2	1-1132	WASHER, Spring
3	1-9213	PULLEY, Poly-Vee Belt
4	1-1724	WASHER, Spring
5	5-9795	HOUSING ASSEMBLY, Right (Includes items 6,7,8,9,10)
6	1-7080	HOUSING, Right Side
7	1-4155	SCREW, 5/16-24x1-1/8" Rib Neck (3)
8	1-2314	SEAL, 5/8" ID (2)
9	1-2507	BEARING, Differential (2)
10	1-1767	BEARING, Ball
11	1-1133	PLUG, Housing
12	5-0767	GEAR, Input
13	5-0830	AXLE, Short
14	1-2495	GEAR, Differential, 46 Tooth
15	3-1970	PLATE (2)
16	3-1965	WASHER, Thrust (2)
17	9-0557	SCREW, Cap, 10-32x1-1/2" (4)
18	1-1774	GASKET, Housing
19	9-0189	WASHER, 5/16" Internal External Tooth Lock
20	5-1903	BRACKET, Differential
21	9-0911	SCREW, 1/4-20x1-1/4 Self-Tapping (4)
22	1-2543	SPACER, Axle Gear
23	5-0831	AXLE, Long
24	2-1115	GEAR, Pinion, 12 Tooth (4)
25	1-2500	SPACER, Pinion Gear (4)
26	1-1110	SHAFT, Pinion (4)
27	9-0376	LOCKNUT, 10-32 (4)
28	5-7523	HOUSING ASSEMBLY, Left (Includes items 8,9,29)
29	1-7015	HOUSING, Left Side

REAR WHEEL BRACKETS, LATCHES

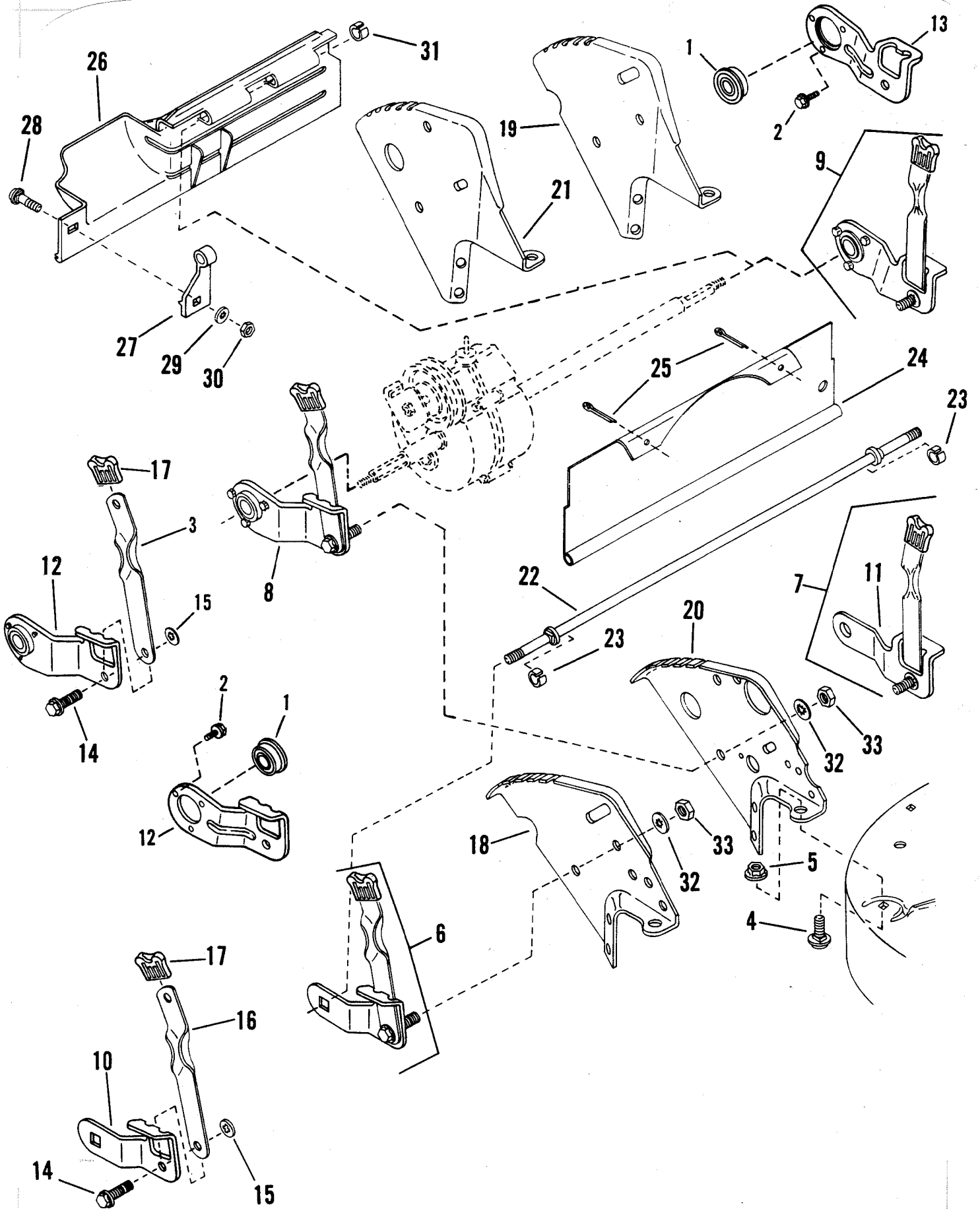

ITEM	PART NO.	DESCRIPTION
1	1-8767	BEARING
2	9-1012	SCREW, #10-32x3/8" Self-Tapping (3)
3	1-9218	LATCH, Height Adjusting (Self-Propelled Models)
4	9-0731	BOLT, 5/16-18x1/2" Short Neck Carriage
5	9-0585	NUT, 5/16-18 Hex Flange Lock (6)
6	5-1954	WHEEL ARM ASSEMBLY (Front Left & Rear Right) (Square opening-Includes Items 10,14,15,16,17)
7	5-1955	WHEEL ARM ASSEMBLY (Front Right & Rear Left) (Round opening-Includes Items 11,14,15,16,17)
8	5-1814	WHEEL ARM ASSEMBLY (Rear Right "P" Models) Includes items (1,2,3,12,14,15,16,17,25)
9	5-1815	WHEEL ARM ASSEMBLY (Rear Left "P" Models) Includes items (1,2,3,13,14,15,16,17,25)
10	3-1016	ARM (Square Axle End)
11	3-1017	ARM (Round Axle End)
12	3-2722	ARM, Wheel Rear Right "P" Models
13	3-2723	ARM, Wheel Rear Left "P" Models
14	1-5761	BOLT, 5/16-18x1 Shoulder
15	1-1791	RETAINER, 5/16 Bolt
16	1-2325	LATCH, Height Adjusting (Push Models)
17	2-7702	GRIP, Latch
18	3-6050	BRACKET, Right Rear Wheel (Push Models)
19	3-6049	BRACKET, Left Rear Wheel (Push Models)
20	3-6048	BRACKET, Right Rear Wheel (Self-prop. "P" Models)
21	3-6242	BRACKET, Left Rear Wheel (Self-prop. "P" Models)
22	2-1119	AXLE, (Rear on Push Models also front on all)
23	1-1780	RING (2) (Push Models)
24	3-7765	GUARD, Rear Foot (Push Models)
25	9-0297	PIN, 1/8x1-1/2" Cotter (2)
26	1-9522	GUARD, Rear Foot (Self-prop. "P" Models)
27	1-2616	SUPPORT, Foot Guard
28	9-0005	BOLT, 1/4-20x1/2 Short Neck Carriage Gr.5
29	9-1023	WASHER, 1/4 Int. Tooth Lock
30	9-0063	NUT, 1/4-20 Hex
31	2-3791	RING
32	9-0391	WASHER, 5/16 Int. Tooth Lock
33	9-0196	NUT, 5/16-18 Hex

REAR WHEELS

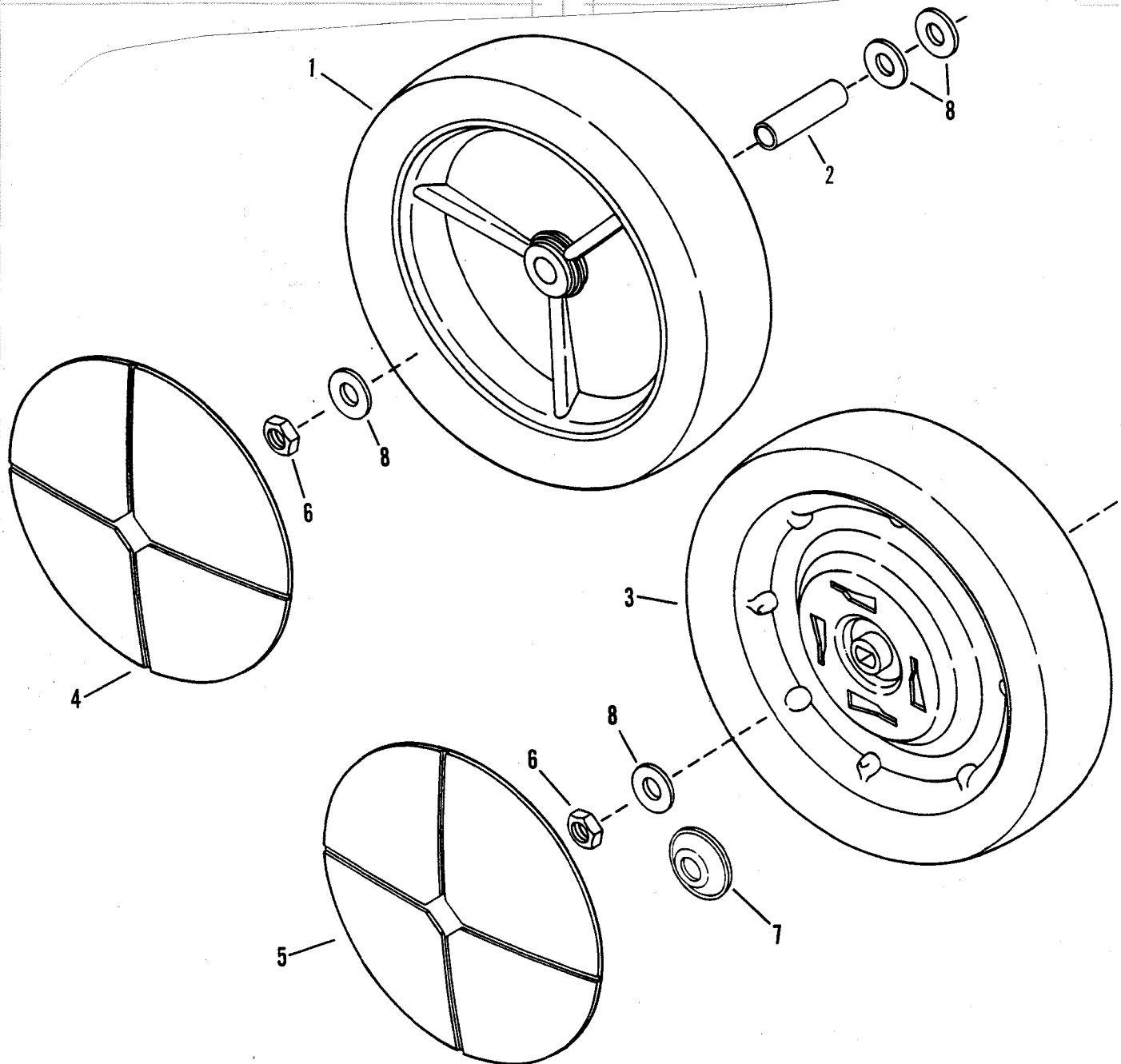

ITEM	PART NO.	DESCRIPTION
1	1-9334	WHEEL, 9x2.00 Plastic Rim (Push Models)("91 Models & Later)
-	1-9196	WHEEL, 9x2.00 Plastic Rim (Push Models)("90 Models & Earlier)
2	1-2309	BUSHING, Axle (Push)
3	1-9336	WHEEL, 9x2.00 Steel Rim (Self-Propelled)("91 Models & Later)
-	1-9198	WHEEL, 9x2.00 Steel Rim (Self-Propelled)("90 Models & Earlier)
4	1-9385	COVER, Wheel (Push & w.5 H.P. Self-Propelled)
5	1-9349	COVER, Wheel (Self-Propelled)
6	9-0377	NUT, 5/16-18 Hex Center Lock (2)
7	3-1960	CAP, Deep-Dish Hub (Self-Propelled)(Steel Wheels)
8	3-1961	WASHER, 7/16 Flat

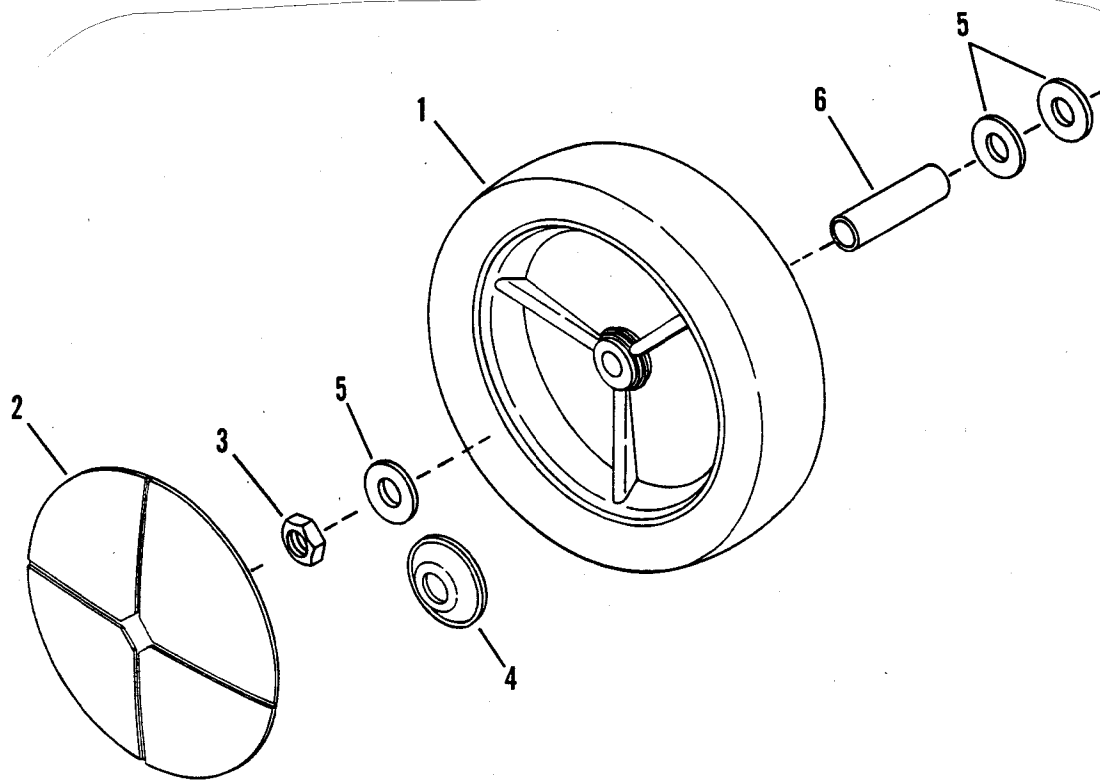

QTEM	PART NO.	DESCRIPTION
1	1-9333	WHEEL, 7x1.75 Plastic Rim ('91 Models & Later)
-	1-9195	WHEEL, 7x1.75 Plastic Rim ('90 Models & Earlier)
2	1-9381	COVER, Wheel
3	9-0377	NUT, 7/16-20 Hex Center Lock (2)
4	3-1960	CAP, Deep-Dish Hub ('90 Models & Earlier)
5	3-1961	WASHER, 7/16 Flat
6	1-2309	BUSHING, Axle

FRONT WHEEL BRACKET, LATCHES

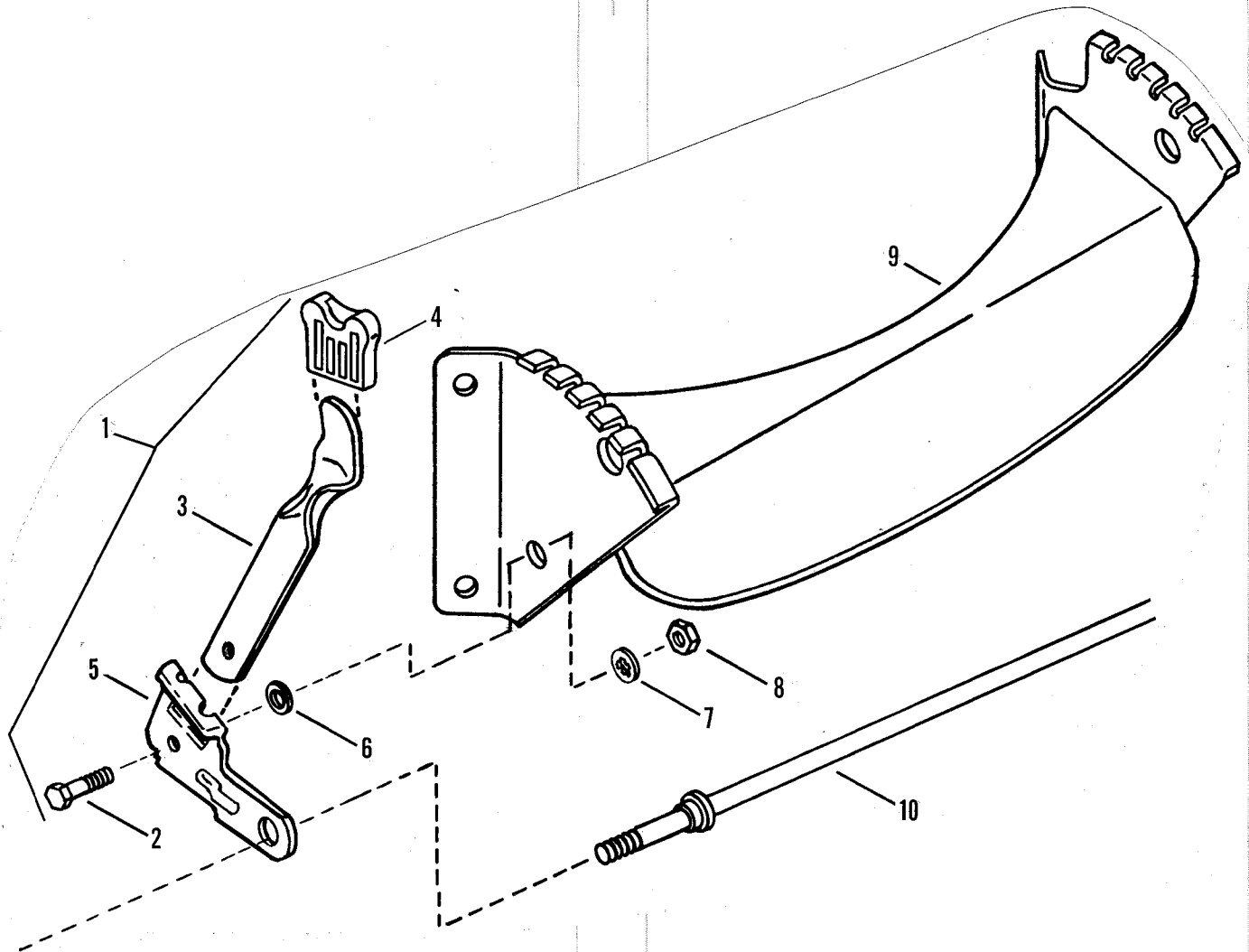

ITEM	PART NO.	DESCRIPTION
1	5-1885	ARM ASSEMBLY, Left Wheel (Consists of Items 8,9,10,11A,12)
-	5-1886	ARM ASSEMBLY, Right Wheel (Consists of Items 8,9,10,11B,12)
2	1-5761	BOLT, 5/16-18 Shoulder
3	1-2325	LATCH, Helght
4	2-7702	GRIP, Latch
5A	3-1016	ARM, Left Wheel
5B	3-1017	ARM, Right Wheel
6	1-1791	RETAINER, 5/16 Bolt
7	9-0391	WASHER, 5/16 Internal Tooth Lock
8	9-0196	NUT, 5/16-18 Hex
9	4-7971	BRACKET, Front Wheel
10	2-1119	AXLE

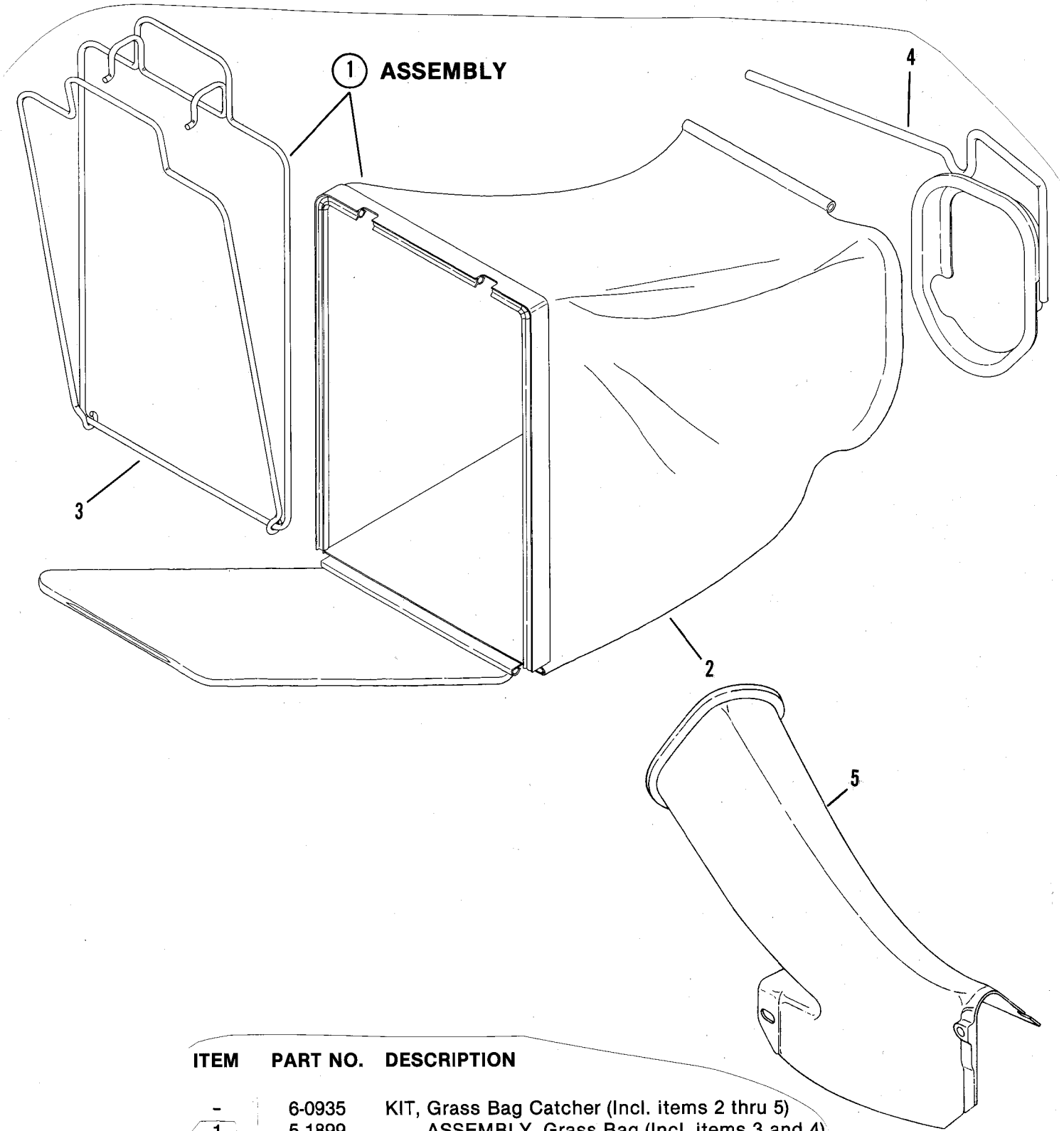

ITEM	PART NO.	DESCRIPTION
-	6-0935	KIT, Grass Bag Catcher (Incl. items 2 thru 5)
1	5-1899	ASSEMBLY, Grass Bag (Incl. items 3 and 4)
2	1-7069	BAG, Door Type (Charcoal)
3	5-1906	ASSEMBLY, Bag Wire
4	4-7969	CONNECTOR, Grass Bag
5	1-6050	ADAPTER, Bag

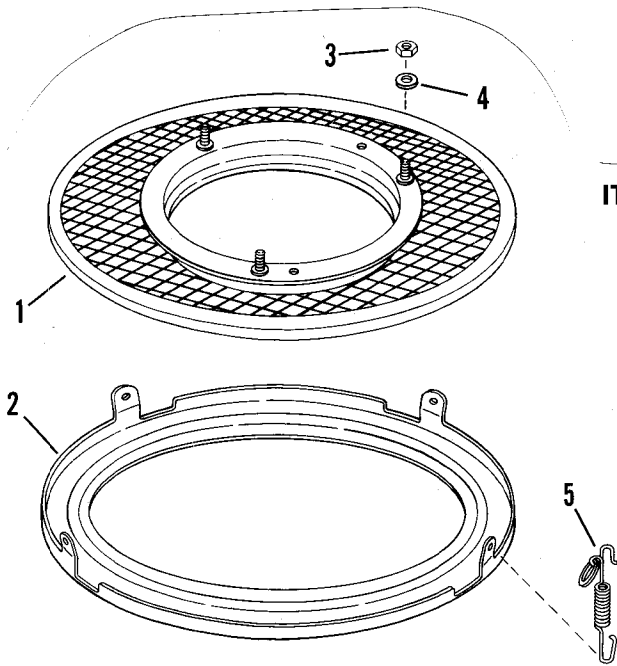

ITEM	PART NO.	DESCRIPTION
	6-0440	KIT, Snapperizer (Includes items 1 thru 5)
1	5-1243	SCREEN, Fastener Assembly
2	3-9759	RING, Bottom
3	9-0223	NUT, 5/16-24 Hex (3)
4	9-0187	WASHER, 5/16 Split Lock (3)
5	1-2587	SPRING (3)

DECALS

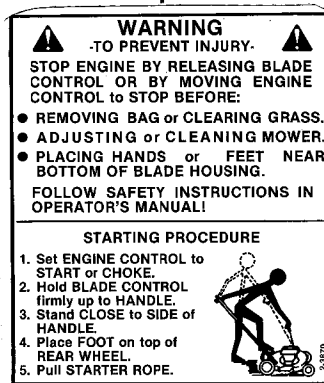
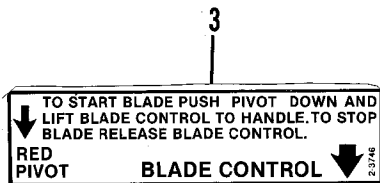

ITEM	PART NO.	DESCRIPTION
1	1-3010	DECAL, CPSC (Danger)
2	2-3870	DECAL, Warning & Starting
3	2-3746	DECAL, Blade Start
4	1-9279	DECAL, SNAPPER
-	1-7149	DECAL, SNAPPER
5	1-6191	DECAL, Warning & Starting

SEE PAGE 8.1 FOR OTHER DECALS

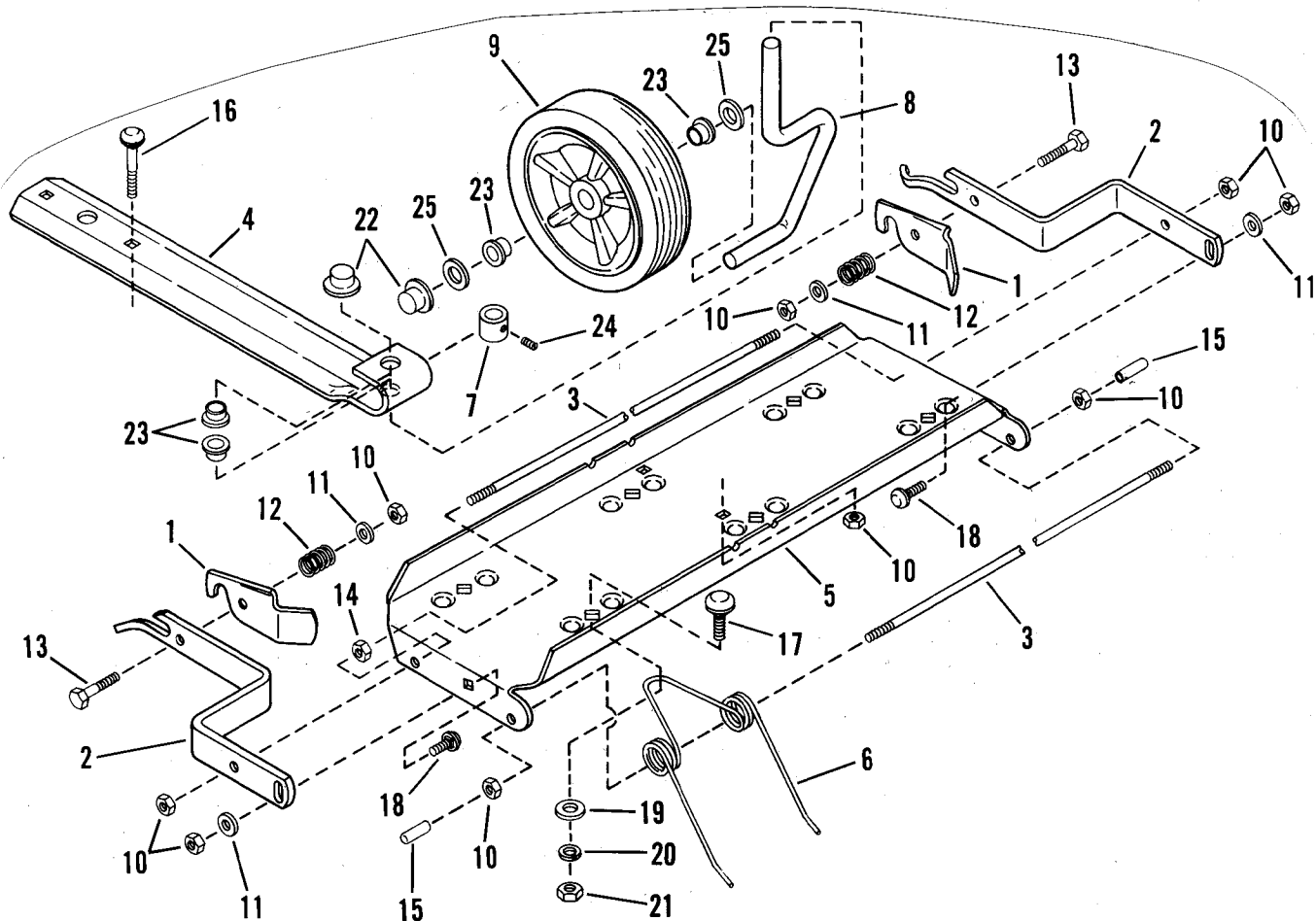

ITEM	PART NO.	DESCRIPTION	ITEM	PART NO.	DESCRIPTION
-	6-0476	KIT, Thatcherizer (Includes 1 thru 27)			
1	1-4113	LATCH, Frame Attachment (2)	14*	9-0063	NUT, 1/4-20 Hex (2)
2A	1-8497	BAR, Mount (Right Hand)	15**	1-4111	CAP, Vinyl (2)
2B	1-8498	BAR Mount (Left Hand)	16*	9-0015	BOLT, 1/4-20x1-3/4 Carriage (2)
3	1-8499	ROD, Tine (2)	17*	9-0383	BOLT, 5/16-18x1 Carriage (6)
4	1-8700	SUPPORT, Wheel	18*	9-0074	BOLT, 1/4-20x3/4 Carriage (2)
5	1-9948	TRAY, Tine	19*	1-4098	WASHER, Reinforcing (6)
6***	1-8496	SPRING, Tine Thatching (6)	20*	9-0187	LOCKWASHER, 5/16 (6)
7**	1-4100	BUSHING, Wheel Adj.	21*	9-0196	NUT, 5/16-18 Hex (6)
8	1-8493	AXLE, Wheel	22**	1-4101	PUSH NUT, 1/2 (2)
9	1-8189	WHEEL, Gage 7x1.50	23**	1-4342	BEARING, Nyliner (4)
10*	9-0761	LOCKNUT, 1/4-20 Hex (10)	24**	1-4103	SETSCREW, 5/16x1/4
11*	9-0598	WASHER, 1/4 SAE (4)	25*	9-0250	WASHER, 1/2 (2)
12**	1-4114	SPRING, Compression (2)	26	1-4115	DECAL, Adjustment (Not Shown)
13*	9-0825	BOLT, 1/4-20x1-1/4 Hex (2)	27	1-4062	DECAL, Thatcherizer (Not Shown)

*Part of Hardware Bag #6-0554

**Part of Hardware Bag #6-0555

***Part of Hardware Bag #6-0574 (6 spring in bag)

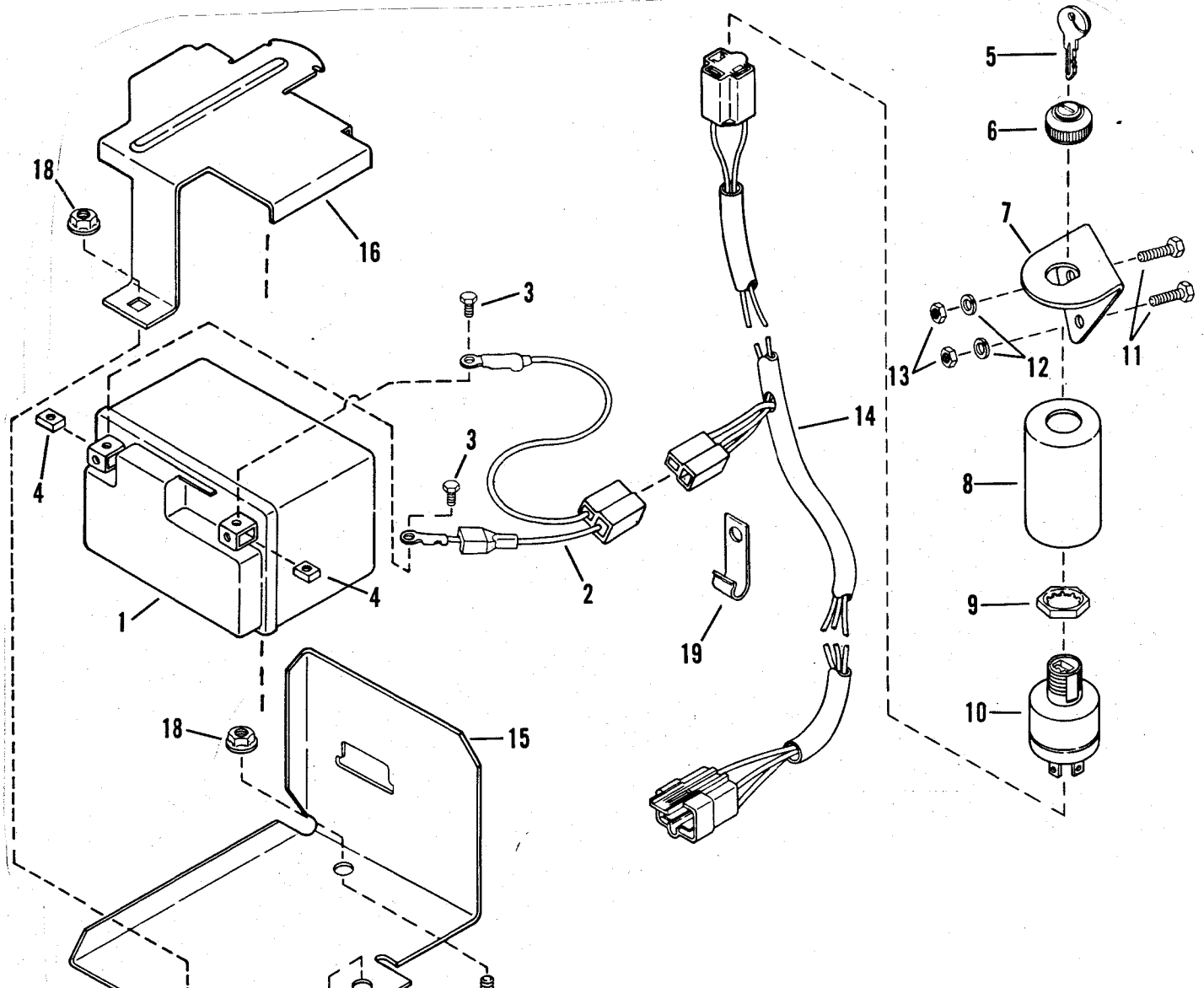

ITEM PART NO. DESCRIPTION

-	6-7012	KIT, Battery (Includes Items 1,2,3,& 4)
1	1-9763	BATTERY, 12 Volt
2	1-5488	HARNESS, Battery
3	4-3977	SCREW, #10-24x1/2" Hex Head Cap (2)
4	9-0932	NUT, #10-24 Square (2)
-	5-1910	ASSEMBLY, Switch/Bracket (Includes Items 5 thru 10)
5	1-1167	KEY, (Set of 2)
6	1-5207	ASSEMBLY, Seal & Face Nut
7	3-8485	BRACKET, Ignition Switch
8	2-3894	COVER, Switch
9	1-5206	NUT, 3/4-20 Lock
10	1-5205	SWITCH, Ignition
11	9-0552	SCREW, 1/4-28x1 3/8" Hex Head Cap (2)
12	9-0053	WASHER, 1/4 Internal Tooth Lock (2)
13	9-0095	NUT, 1/4-28 Hex (2)
14	1-9298	HARNESS, Wiring ('90 Models & Earlier)
-	1-7213	HARNESS, Wiring ('91 Models & Later)
15	3-2906	BRACKET, Battery (Self-Propelled Models)
16	3-8132	COVER, Battery (Self-Propelled Models)
17	9-0731	BOLT, 5/16-18x1/2" Carriage (3)
18	9-0585	NUT, 5/16-18 Hex Flange Lock (3)
19	1-2652	CLIP, Wiring
20	1-8834	CHARGER, Battery (60 Hertz)

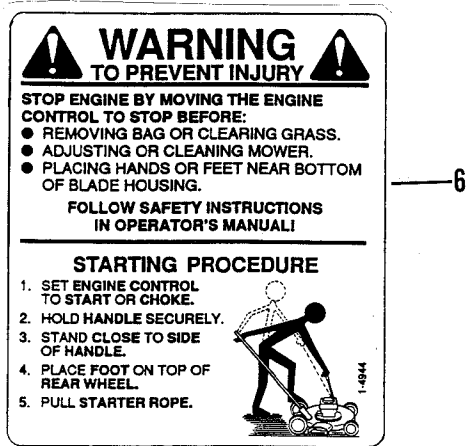
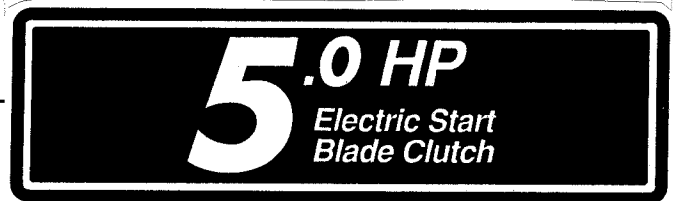
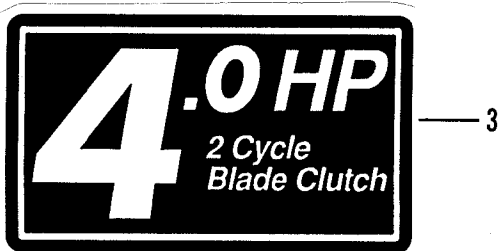

ITEM	PART NO.	DESCRIPTION
1	1-7301	DECAL, Recoil Housing (3.85 O.D.)
2	1-7294	DECAL, Recoil Housing (2.58 O.D.)
3	1-7299	DECAL, 4.0HP 2-Cycle
4	1-7308	DECAL, 5.0HP Electric Start
5	1-7307	DECAL, 5.0HP
6	1-4944	DECAL, Warning

Parts Manual for

SNAPPER®

21" SERIES 6

BLADE BRAKE CLUTCH

WALK MOWERS

IT IS THE POLICY OF SNAPPER POWER EQUIPMENT TO IMPROVE ITS PRODUCTS WHENEVER IT IS POSSIBLE AND PRACTICAL TO DO SO. WE RESERVE THE RIGHT TO MAKE CHANGES OR ADD IMPROVEMENTS AT ANY TIME WITHOUT INCURRING ANY OBLIGATION TO MAKE SUCH CHANGES ON PRODUCTS MANUFACTURED PREVIOUSLY.

SNAPPER POWER EQUIPMENT

McDonough, GA • 30253



MANUAL #06132

**(REV. 1,2/91)
(REPLACES I.R. 9/89)**

PRINTED IN U.S.A.