



USER'S MANUAL



LC-500

DOT MATRIX PRINTER

CFA10EC 80826160

CE
Manufacturer's Declaration of Conformity

EC Council Directive 89/336/EEC of 3 May 1989

This product, has been designed and manufactured in accordance with the International Standards EN 50081-1/01.92 and EN 50082-1/01.92, following the provisions of the Electro Magnetic Compatibility Directive of the European Communities as of May 1989.

EC Council Directive 73/23/EEC and 93/68/EEC of 22 July 1993

This product, has been designed and manufactured in accordance with the International Standards EN 60950, following the provisions of the Low Voltage Directive of the European Communities as of July 1993.

The above statement applies only to printers marketed in EU.

Trademark acknowledgments

LC-500: Star Micronics Co., Ltd.

ESC/POS: Seiko Epson Corporation

Notice

- All rights reserved. Reproduction of any part of this manual in any form whatsoever, without STAR's express permission is forbidden.
- The contents of this manual are subject to change without notice.
- All efforts have been made to ensure the accuracy of the contents of this manual at the time of going to press. However, should any errors be detected, STAR would greatly appreciate being informed of them.
- The above notwithstanding, STAR can assume no responsibility for any errors in this manual.

Contents

1. Printer Setup	1
Choosing a place for the printer	1
Unpacking the printer	2
Printer Components	3
Installing the paper guide	4
Opening the printer cover	4
Removing the printer cover	5
Connecting the Power Cord and turning the power ON and OFF....	6
Installing the ribbon cassette	7
Removing the ribbon cassette	10
Connecting to your computer using the parallel cable	10
Ferrite Core Installation	11
2. Paper Handling	13
Selecting paper types	13
Cut-sheet paper	13
Fanfold paper	13
Loading cut-sheet paper.....	14
Printing on cut-sheet paper	17
Loading fanfold paper	18
Printing on fanfold paper	22
Parking fanfold paper	23
Unparking fanfold paper	23
3. Control Panel Operations	24
Switching between on-line and off-line	25

Control panel functions in on-line mode	25
Control panel functions in off-line mode	27
4. Using the EDS Mode.....	30
About EDS Mode settings	30
Entering the EDS Mode.....	30
Selecting a EDS number	31
Selecting a bank.....	31
Selecting a switch	31
Changing a switch setting.....	31
Printing the current EDS settings	31
Exiting the EDS Modes	31
5. Control Codes List	42
< ESC/P-K mode>	42
6. Troubleshooting	45
Short test	45
Long test	46
Hexadecimal dump	46
Adjusting the dot alignment	47
Troubleshooting guide	48
Appendix A. Specifications	53
Appendix B. Character Sets	56
Appendix C. Control Panel Operation Guide....	67

1. Printer Setup

This chapter contains important information on setting up your printer. Be sure to read this chapter carefully before using the printer for the first time.

Choosing a place for the printer

Before unpacking the printer from the box, plan the installation location of your printer. Consider the following points.

- ✓ Choose a firm, level surface where the printer will not be exposed to vibration.
- ✓ The power outlet you plan to connect to for power should be nearby and unobstructed.
- ✓ Make sure that the printer is close enough to your computer for you to connect the two with your printer cable.
- ✓ Allow six inches (15 centimeters) of free space on either side and in the back of the printer.
- ✓ Make sure that the printer is not exposed to direct sunlight.
- ✓ Make sure that the printer is well away from heaters.
- ✓ Make sure that the surrounding area is clean, dry, and free of dust.
- ✓ Make sure that the printer is connected to a reliable power outlet. It should not be on the same electric circuit as copiers, refrigerators, or other appliances that cause power spikes.
- ✓ Use a power outlet that matches the power rating noted on the label affixed to the bottom of your printer.
- ✓ Make sure that the room where you are using the printer is not too humid.

Unpacking the printer

Check that the package contains the following items.

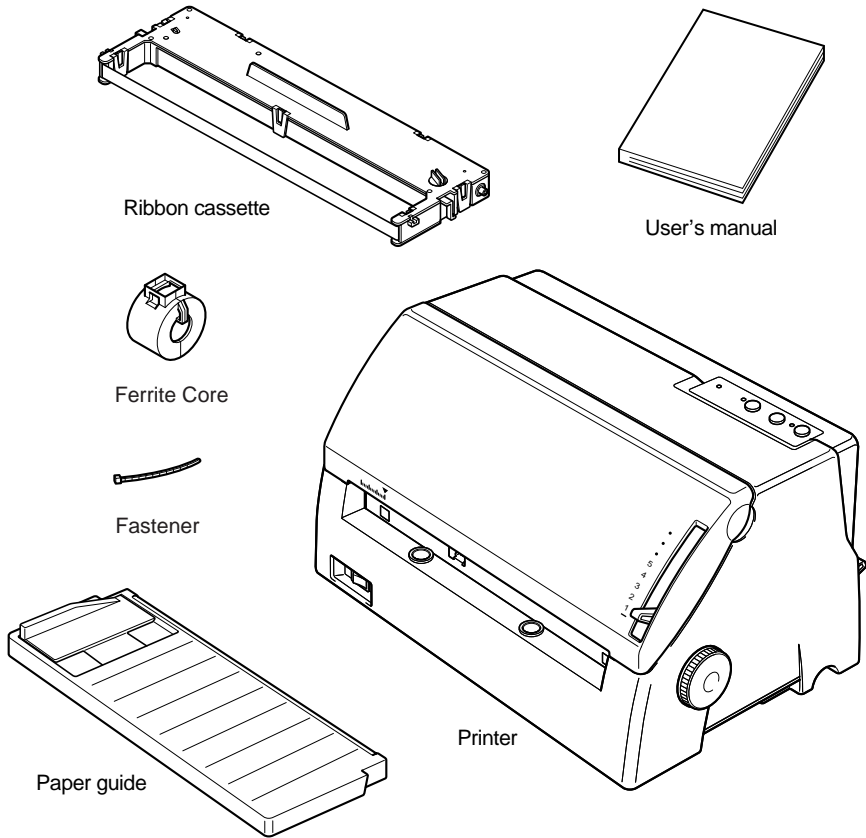

If any item is missing, contact the store where you bought the printer and ask them to supply the missing part. Note that it is a good idea to keep the original box and all packing materials in case you need to transport the printer at a later date.

Important!

There are several versions of this printer designed for different voltages. It is not possible to change the voltage of a printer. If the voltage shown on the label on the back of your printer does not match the voltage for your area, contact your dealer immediately.

Printer Components

The following illustrations show the major components of your printer.

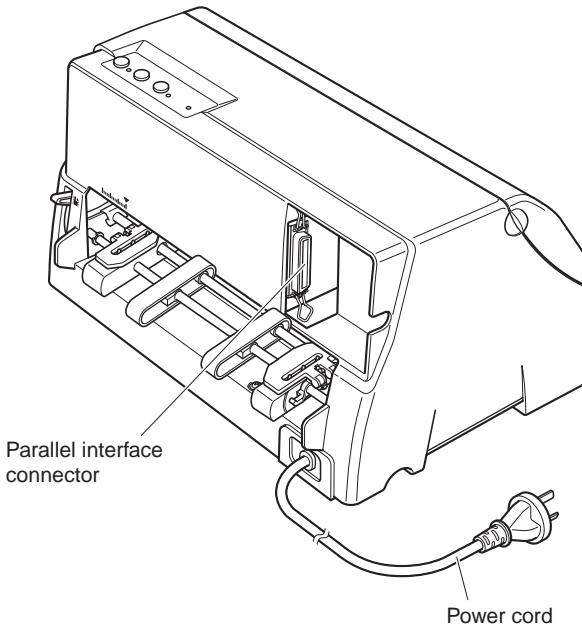
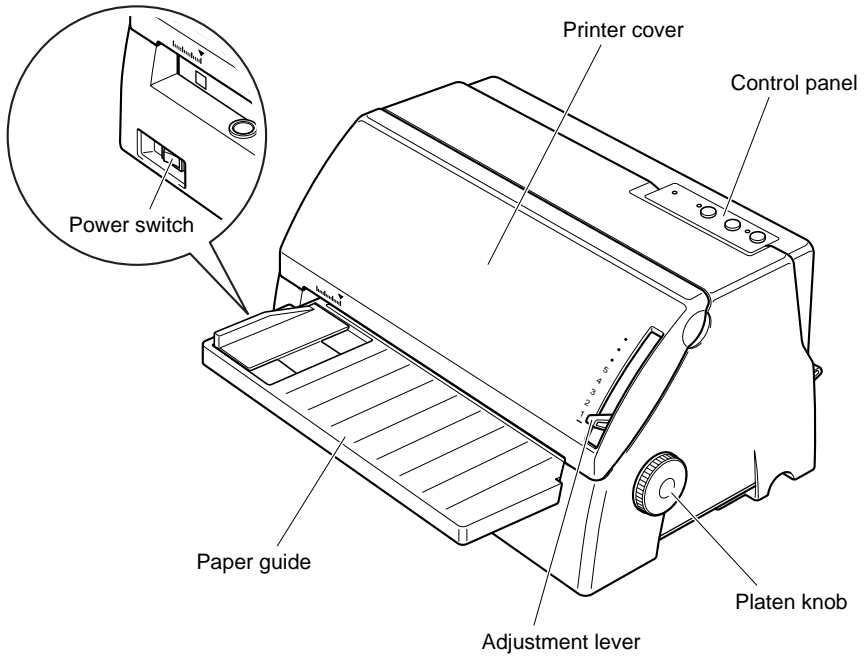

Installing the paper guide

1. Hold the paper guide at a slight angle and slide the two slots on either side of the paper guide into the tabs provided on the printer case.

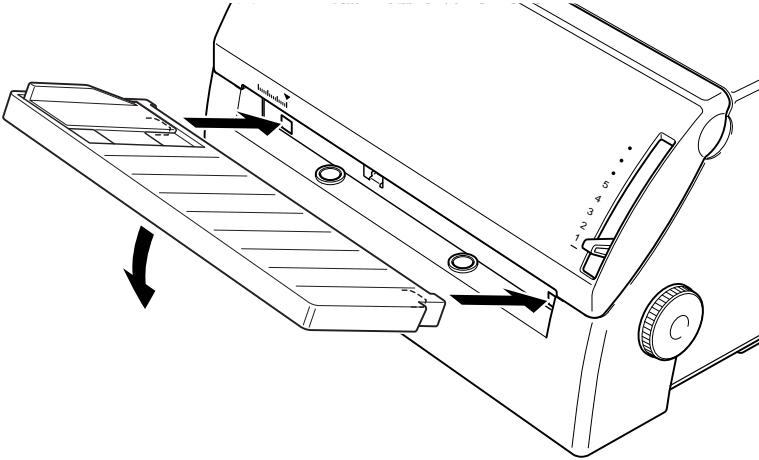

2. Press the paper guide firmly against the tabs until it clicks, and then lower the table to a horizontal position.

Opening the printer cover

Pull on the left and right corners of the printer cover to and swing it down until it is fully open.

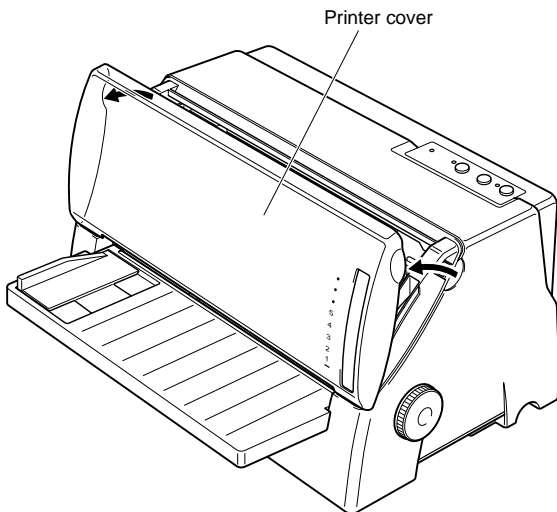

Removing the printer cover

Swing the printer cover so that it is at an angle as shown in the figure below and lift the cover to remove it. To replace the printer cover, lower the two slots on either side of the cover onto the tabs provided on the printer case.

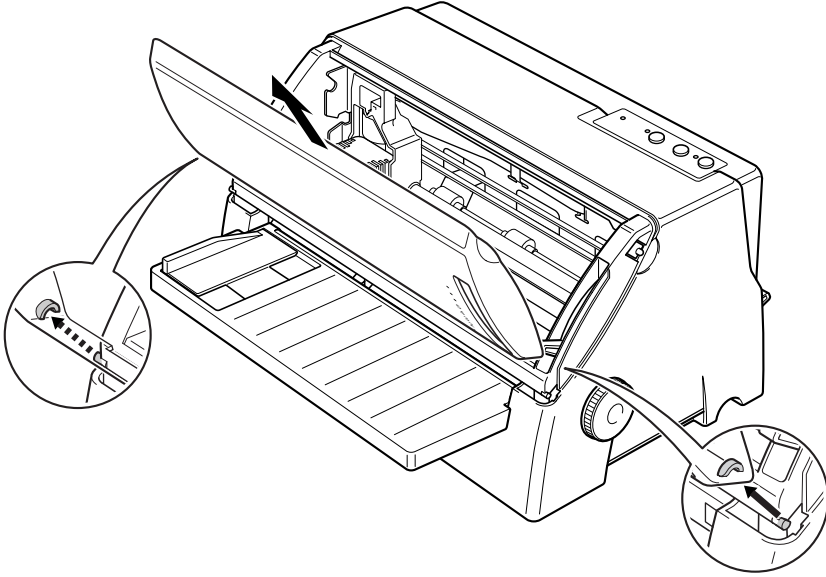

Connecting the Power Cord and turning the power ON and OFF

1. Check that the power switch on the front panel of the printer is in the OFF position (O).

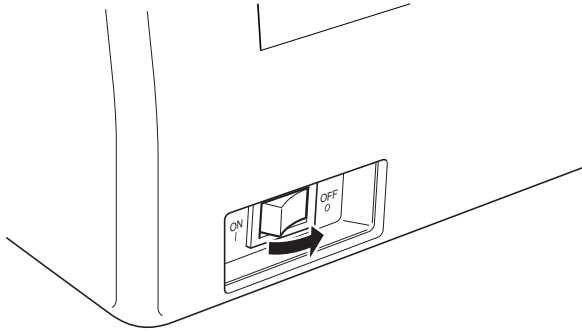

2. Plug the power cord to a power outlet whose voltage matches the power rating noted on the label affixed to the bottom of your printer.

Caution!

1. *If the voltage marked on the rear of your printer does not match the voltage from the outlet you are using, do not plug in the power cord. Contact your dealer for assistance.*
 2. *We recommend that you unplug the printer from the power outlet whenever you do not plan to use it for long periods. Because of this, you should locate the printer so that the power outlet it is plugged into is nearby and easy to access.*
-

3. To turn the power on, press the power switch to the ON position (I); to turn the power off, press the power switch to the OFF position (O).

Installing the ribbon cassette

1. Turn the power on. The carriage moves to the left most position. You will hear beeps when the carriage reaches this position.

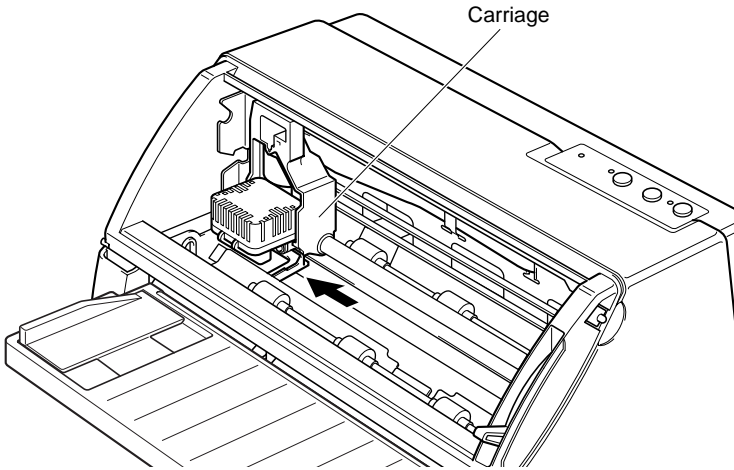

Caution!

Do not move the carriage by hand while the printer is turned on. Doing so can damage the printer. If you have just finished printing, let the print head cool for a few minutes before you touch it.

2. Turn the power off.

3. Set the adjustment lever to the highest position.

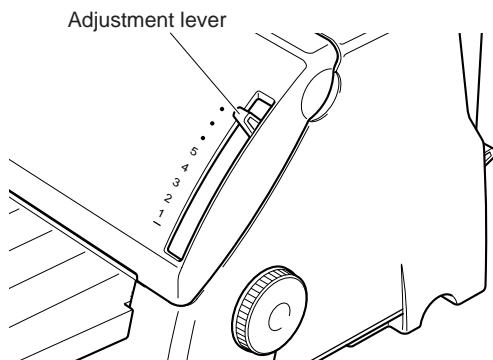

4. Open the printer cover.
5. Remove the ribbon cassette from the package and rotate the knob on the cassette counterclockwise to take up any slack in the ribbon.

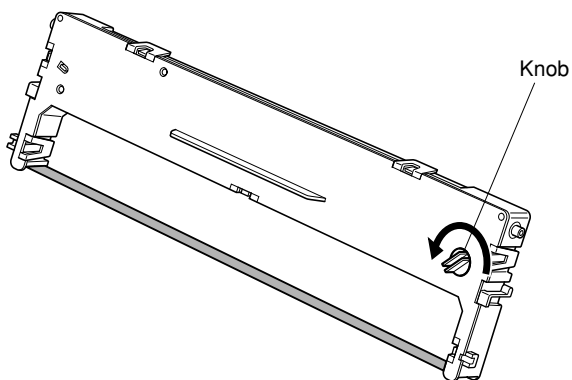

6. While holding the printer cassette at an angle, insert the two round tabs on either side of the ribbon cassette into the two slots inside the printer. Then, press the lower half of the cassette inward to a vertical position until it snaps securely into place.

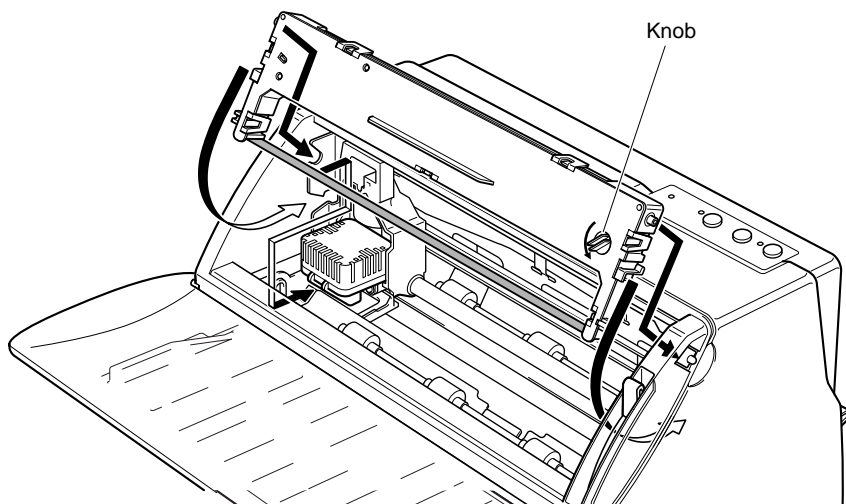

7. Rotate the knob on the cassette counterclockwise so that the ribbon slides under the head.
8. Set the adjustment lever to position 1. Position 1 is for thin paper. You may need to set the adjustment lever to another position, if you are using a thick paper.
9. Close the printer cover.

Important!

Printing that is poor quality or too light is almost always due to a ribbon that is simply worn out or “used up.” If you experience problems with print quality, check the condition of the ribbon. If the black part looks gray and well-worn, replace the ribbon with a new one.

Removing the ribbon cassette

When replacing the ribbon cassette, use the following procedure to remove the old ribbon cassette from the printer.

1. Open the printer cover.
2. Turn the power on. The carriage moves to the left most position. You will hear beeps when the carriage reaches this position.

Caution!

Do not move the carriage by hand while the printer is turned on.

Doing so can damage the printer.

If you have just finished printing, let the print head cool for a few minutes before you touch it.

3. Turn the power off.
4. Pull the lower half of the cassette outward so that the ribbon slides out from under the printer head. Then, lift up the cassette to remove it from the printer.

Connecting to your computer using the parallel cable

Your printer comes equipped with a parallel port.

Since the printer does not come with cables, you must purchase an appropriate cable that matches your computer. Below is an illustration of a typical parallel cable.

Important!

The following instructions apply to the Centronics parallel cable that is suitable for use with an IBM-compatible personal computer. Note that they do not apply to all types of computers and cables. If you are unsure about what type of cable you should use, consult your dealer.

For an IBM-compatible personal computer:

- Use a standard 36-pin Centronics parallel cable.
- The parallel cable should be no longer than six feet (two meters). Longer cables can result in poor transfer of information.

Ferrite Core Installation

1. Strap the fastener into the parallel interface cable as shown in the illustration below.
2. Cut off the surplus part of the fastener.

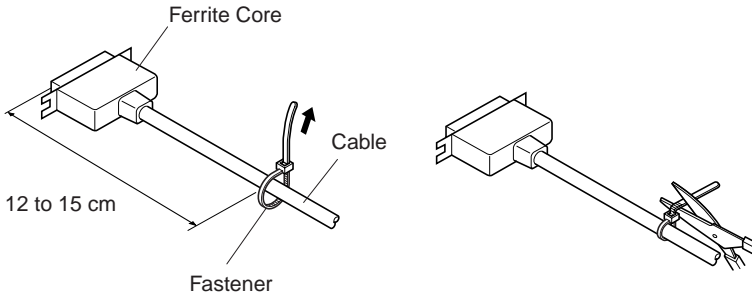

3. With a regular screwdriver, unlatch and open the ferrite core.
4. Attach the ferrite core onto the cable as shown in the illustration below.

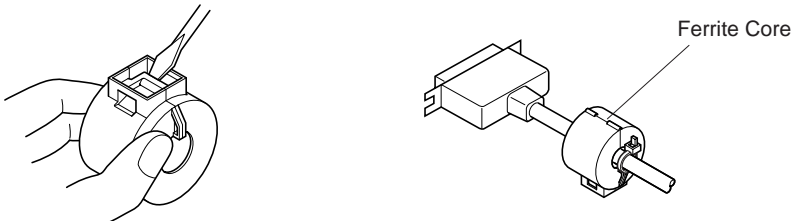

Important!

Make sure that the printer is unplugged from the AC outlet and that the computer is turned off before connecting the parallel cable.

1. Connect one end of the parallel cable to the parallel port of your computer. The parallel port is usually labeled “Printer,” “Parallel,” “PRN,” “LPT1,” or something similar.
2. Connect the other end of the parallel cable into the socket on the back of the printer and secure it in place with the clips.

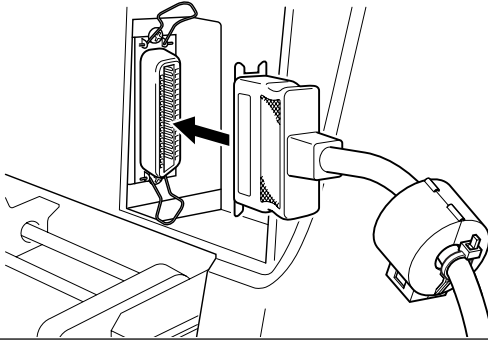

Note:

If your computer is located to the right of the printer, run the cable under the computer through the groove at the bottom of the printer. This will prevent the cable from interfering with the fanfold paper. You can also run the power cord under the printer.

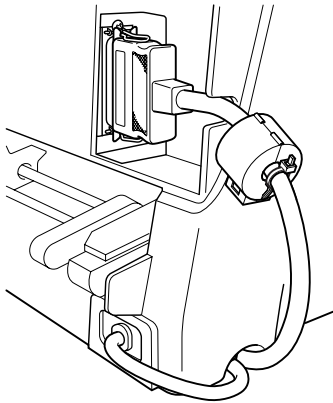

2. Paper Handling

This chapter describes the different types of paper you can print on and how to setup the printer for each type.

Selecting paper types

Use the following information when selecting paper.

Cut-sheet paper

Width:	125 to 257 mm / 4.9 to 10.12 inches
Length:	85 to 364 mm / 3.3 to 14.33 inches
Paper Sizes:	A6: 105 x 148 mm (Landscape) B6: 128.5 x 182 mm (Portrait, Landscape) A5: 148 x 210 mm (Portrait, Landscape) B5: 182 x 257 mm (Portrait, Landscape) A4: 210 x 297mm (Portrait) B4: 257 x 364mm (Portrait)) Executive: 7.25 x 10.5 inches (Portrait) Letter: 8.5 x 11 inches (Portrait) Legal: 8.5 x 14 inches (Portrait)
Thickness	
1-ply only:	0.05 to 0.18 mm
Multi-ply:	0.05 to 0.35 mm
Weight	
1-ply only:	52 to 156 g/m ² / 14 to 42 lbs / 45 to 135kg
Multi-ply:	40 to 52 g/m ² / 11 to 14 lbs / 34 to 45kg

Fanfold paper

Width:	139.7 to 254 mm / 5.5 to 10 inches
Length:	Min. 5.5 inches
Thickness	
1-ply only:	0.07 to 0.11 mm
Multi-ply:	Max. 0.35 mm
Weight	
1-ply only:	52 to 82 g/m ² / 14 to 22 lbs / 45 to 70kg
Multi-ply:	40 to 52 g/m ² / 11 to 14 lbs / 34 to 45kg

Loading cut-sheet paper

This section describes the procedure for loading cut-sheet paper. You can also use fanfold paper. For details on using fanfold paper, see “Loading fanfold paper” on page 18. If the fanfold paper is currently loaded, first park the fanfold paper using the procedures described in “Parking fanfold paper” on page 23.

1. Set the release lever to the cut-sheet position.

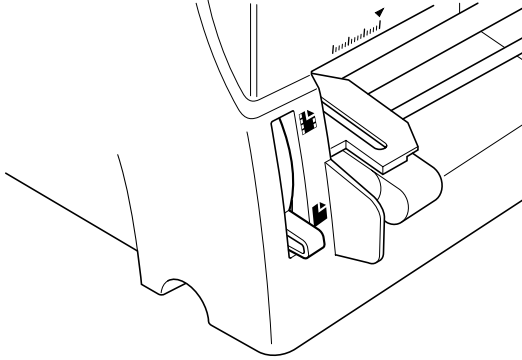

2. Set the adjustment lever to the value that matches the thickness of the paper you are using. The setting for normal paper is 1. Set the lever to a larger value for thicker paper, or to a smaller value for thinner paper.

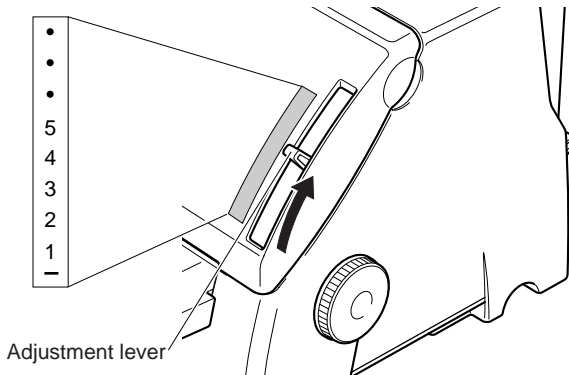

The following table provides a general guide for setting the adjustment lever. Experiment with different settings until you find the one that gives you the print quality you want.

Paper Type		Weight Per Sheet	Thickness	Recommended Position
Single-sheet		30 g/m ²	0.05 mm	1
		64 g/m ²	0.08 mm	1
		90 g/m ²	0.12 mm	1 to 2
		156 g/m ²	0.19 mm	2
Multi-part	2-ply	40 to 52 g/m ²	0.13 mm	2
	3-ply	40 to 52 g/m ²	0.20 mm	3
	4-ply	40 to 52 g/m ²	0.26 mm	5
	5-ply	40 to 52 g/m ²	0.32 mm	6

Important!

Continuous use of the wrong adjustment lever setting can drastically reduce the print head life. Position “-” is used only when the print quality is too light. Setting the lever to position “-” when you are using thin paper may damage the print head.

- Adjust the paper edge to the desired position. The ▼ mark of the guide indicates where the left margin of the printing will be.

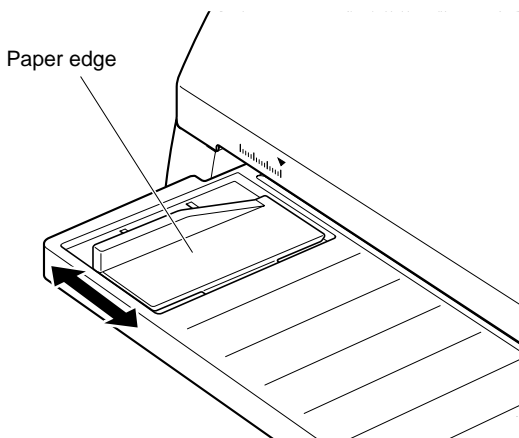

4. Insert the paper from the front of the printer as far as it will go, sliding the left side of the paper against the paper edge. Insert the paper facing up, with the top towards the printer.

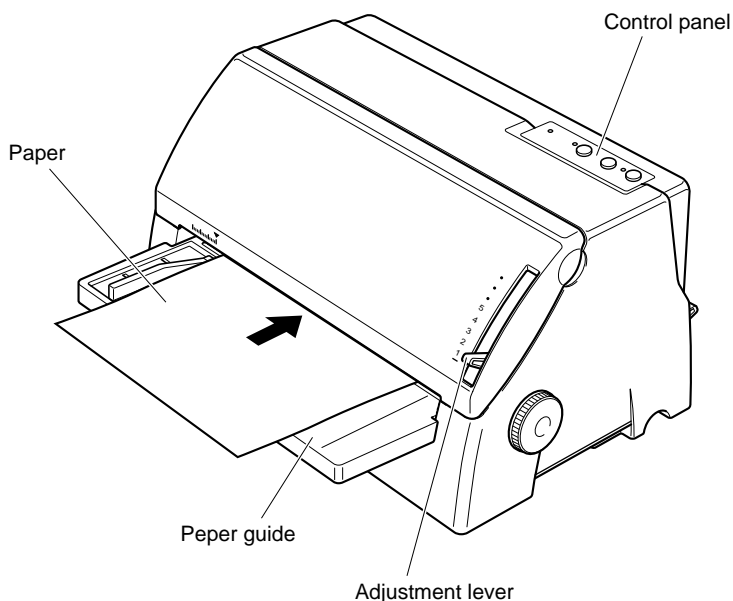

The paper will automatically be fed into the printer.

5. Start the printing operation from your software application.

After the printing is complete, the paper is ejected from the same position as you inserted the paper.

Printing on cut-sheet paper

The following shows the recommended print area for cut-sheet paper.

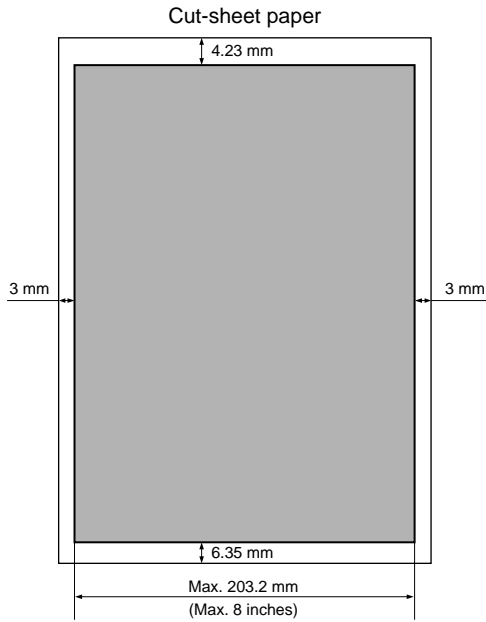

Loading fanfold paper

This section describes the procedure for loading fanfold paper. You can also use cut-sheet paper. For details on using cut-sheet paper, see “Loading cut-sheet paper” on page 14.

1. Position the stack of paper behind the printer. The following figure shows the correct path for fanfold paper.

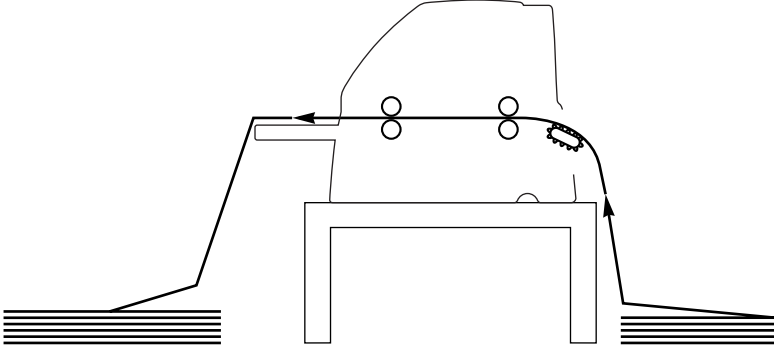

Important!

To protect against paper jams, make sure that the fanfold paper is stacked in a position that is lower than the printer.

To decrease paper jams, be sure that the perforations do not get caught in anything in the paper path.

2. Make sure that the printer is turned off.
3. Set the release lever to the fanfold position.

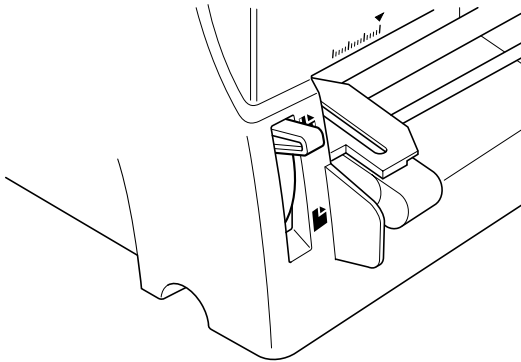

4. Set the adjustment lever to the value that matches the thickness of the paper you are using. The setting for normal paper is 1. Set the lever to a larger value for thicker paper, or to a smaller value for thinner paper. See the table on page 15 for details.

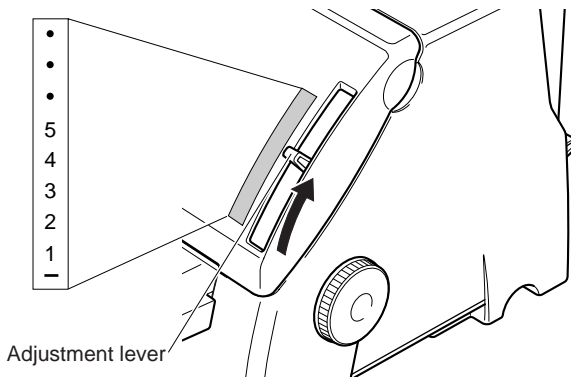

5. Unlock the tractor on the left (when viewing the printer from behind) by pulling its gray lever up, and adjust the position of the left tractor. Note that there is a guide inside the printer in front of the left tractor. The ▲ mark of the guide indicates where the left margin of the printing will be.

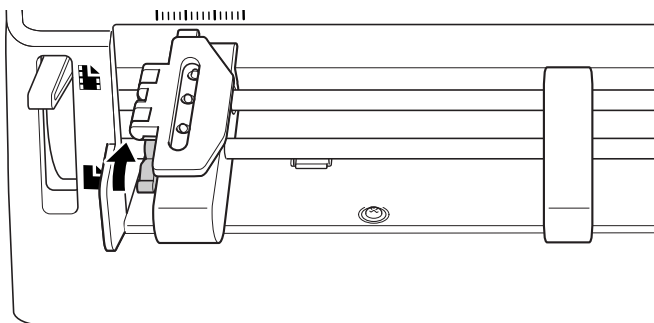

6. Once the left tractor is aligned the way you want it, push the gray lever back down to lock it in place.

7. Now move the tractor on the right to the approximate position of the right side of the paper you are using. Pull its gray lever up to unlock it, and push the lever back down to lock it into place. Also move the sheet guide so that it is approximately halfway between the two tractors.

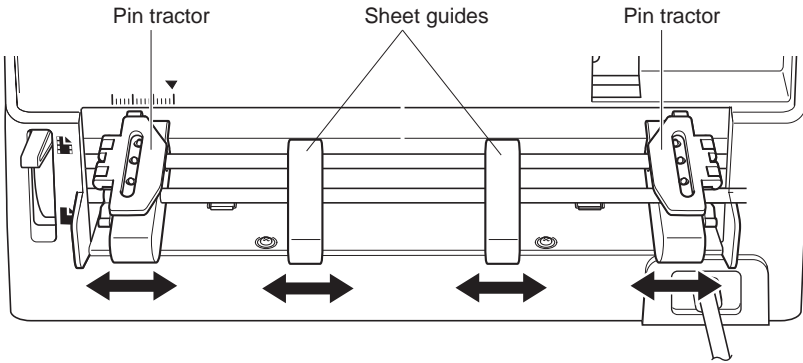

8. Open the covers of both tractors and align the paper so that at least three pins on the tractors are inserted into the holes of the paper.

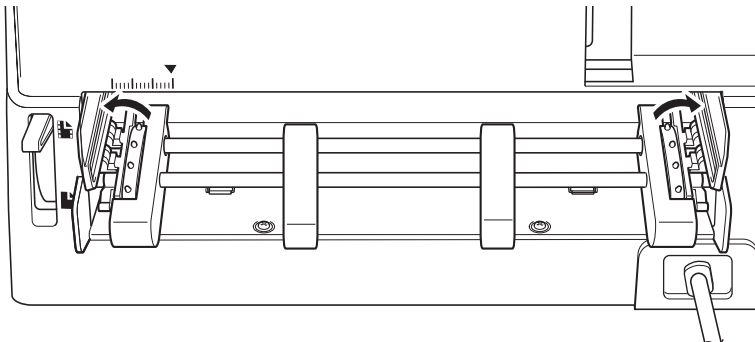

9. Close the tractor covers. At this point you can make final adjustments to the paper position by releasing the gray levers and moving the tractors. The paper should lie flat with no buckling or bulging (tractors too close) or no stretching or elongation of the holes (tractors too far apart). After making these adjustments, be sure that you re-lock the tractors by pushing the gray levers back into their original positions.

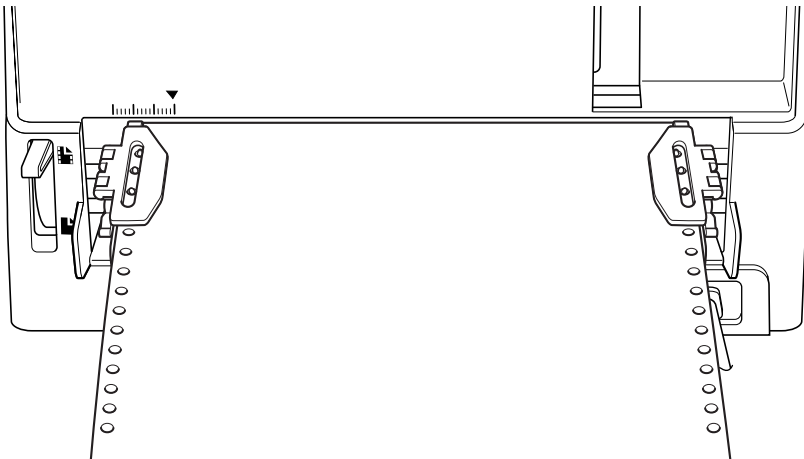
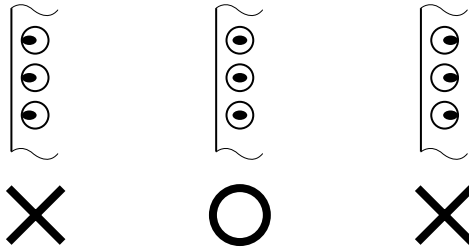

10. Turn the power on.
11. Press the control panel's SET/PARK/EJECT button and the paper will feed to the starting position.

Printing on fanfold paper

When printing on fanfold paper, take care not to print too close to the perforations that separate each sheet. The following shows the recommended print area for fanfold paper and cut-sheet paper.

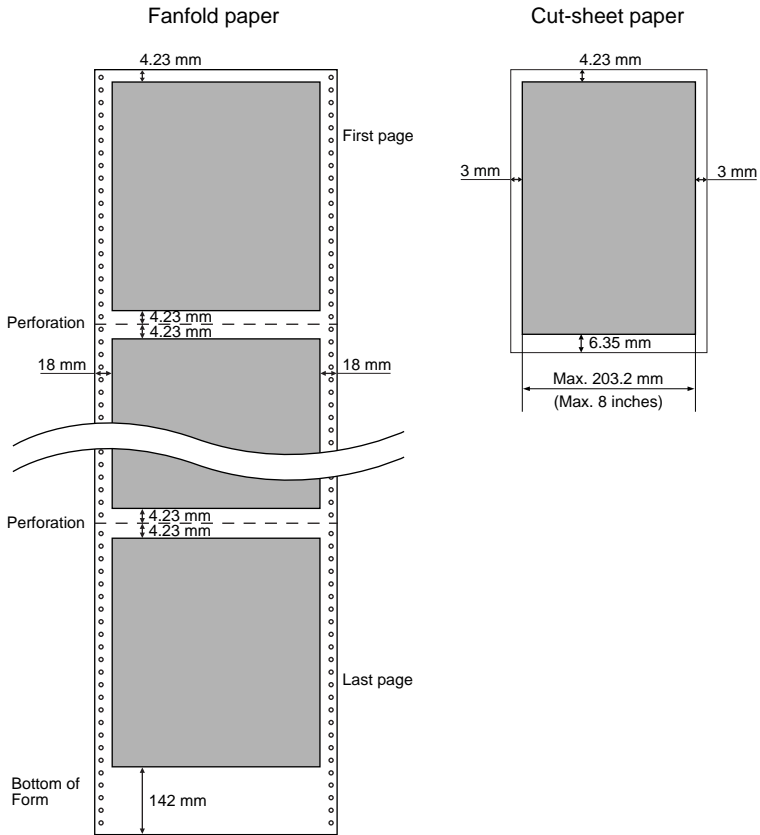

Parking fanfold paper

It is not necessary to remove fanfold paper currently loaded in the printer in order to print on cut-sheet paper. Instead, simply use the following procedure to park the fanfold paper.

1. Press the control panel's ON LINE button to put the printer off-line.
2. Press the control panel's SET/PARK/EJECT button. The printer automatically reverse feeds the fanfold paper until it is no longer in contact with the platen, which is indicated by the printer beeping a number of times. Also, the control panel's POWER indicator starts to flash because paper is not loaded.

You can now load cut-sheet paper into the printer using the procedures described in "Loading cut-sheet paper" on page 14.

Unparking fanfold paper

After you are finished printing on cut-sheet paper, use the following procedure to unpark fanfold paper and make it available for printing.

1. Remove all cut-sheet paper from the printer.
2. Set the release lever to the fanfold position.
3. Press the SET/PARK/EJECT button to feed the paper to the starting position.

The printer automatically goes back on-line at this time.

3. Control Panel Operations

The control panel gives you push-button control over the printer's operations. It also includes indicator lights, which tell you the current status of the printer at a glance.

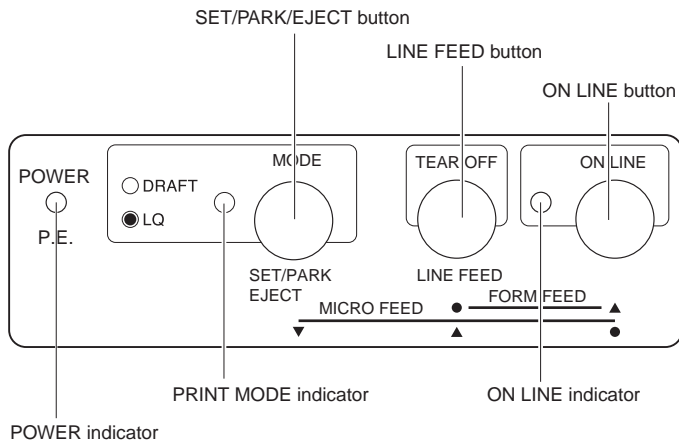

This chapter describes control panel functions that can be performed while the printer is turned on and either on-line or off-line. The buttons perform different functions in the EDS and Dot Adjustment Modes. Functions of control panel buttons in these modes are described in the relevant sections covering them.

Switching between on-line and off-line

- Press the ON LINE button to switch the printer between on-line and off-line modes.
- When the printer is on-line, the ON LINE indicator is lit and the printer can receive data from the computer. Make sure that the printer is on-line whenever you are trying to print.
- When the printer is off-line, the ON LINE indicator is off, which means that the printer cannot receive any data.
- Note that you can also press the ON LINE button while a printing operation is in progress to stop the printing.

Control panel functions in on-line mode

Tear-off function (fanfold paper)

This procedure feeds fanfold paper to a position where it can be torn off easily.

1. Press the LINE FEED button to feed the paper automatically so that the perforation is just past the printer cover.
2. Tear the paper along the perforation.

When you resume printing, the printer reverse feeds the paper to its former position.

Print mode selection

Press the SET/PARK/EJECT button to change the print mode selection. When the print mode is changed, a short buzzer sounds. The mode indicator tells you the current print mode as follows:

Print Mode	Mode Indicator
LQ (Letter Quality)	OFF
Draft	ON

Panel lock mode

When the printer is in the panel lock mode, the mode settings you make on the control panel are used even if your software tries to override the mode. Use the following procedure to enter the panel lock mode.

1. While holding down the SET/PARK/EJECT button, press the LINE FEED button. A short buzzer sounds once.

To exit from the panel lock mode, press the LINE FEED button while holding down the SET/PARK/EJECT button. A short buzzer sounds twice.

Panel macro

The settings you make on the front panel are cleared when the printer is turned OFF. To save the current control panel settings so that they are used the next time the printer is turned ON, use the following procedure.

1. While holding down the SET/PARK/EJECT button, press the ON LINE button. Keep both buttons held down until the printer beeps twice.

This procedure saves the following settings.

- Print mode settings
- Panel lock

To clear the panel macro, hold down SET/PARK/EJECT and ON LINE until the printer beeps 3 times. If EDS2A-5 is OFF, this panel macro function is ignored (see chapter 4).

Control panel functions in off-line mode

Line feed

Press the LINE FEED button once to feed the paper one line. Holding down the LINE FEED button continually feeds the paper, 1/6" (default) at a time, until you release the button.

The line feed is executed using the current line feed value. In Self Test mode, this button is ignored. While this button is held down, line feed is executed up to 13 times. If the button is held down after 13 times of line feed, the paper is continuously fed to the top of the next page. If the ON LINE button is pressed while this button is held down, form feed is executed.

Set/Park/Eject

Press the SET/PARK/EJECT button to set, eject, or park the paper.

If the paper is not loaded (paper end condition), paper loading is executed. After the paper is loaded completely, the printer switches on-line mode. If the paper is loaded (not paper end condition), the paper is parked when using fanfold paper or ejected when using cut-sheet paper. After the paper is parked or ejected completely, the printer switches to off-line mode.

	Paper Condition	
	Paper End	Not Paper End
When using fanfold paper	Paper load (Paper set)	Paper park
When using cut-sheet paper	Paper load (Paper set)	Paper eject

Form feed

While holding down the LINE FEED button, press the ON LINE button to feed the paper to the top of the next page. If EDS2C-2 is ON (default) when using cut-sheet paper, this function executes paper ejection.

Micro paper feed

Use the following procedure to feed the paper in 1/60-inch increments. This function can be used to align the print head exactly where you want it.

Press the LINE FEED button while holding down the ON LINE button to execute micro paper feed. When Tear Off lifts the paper up, the micro paper feed value is added to the tear off value. If the adjust value is over 1 inch, the micro paper feed is not executed.

Press the SET/PARK/EJECT button while holding down the ON LINE button to execute micro reverse paper feed. When Tear Off lifts the paper up, the micro reverse paper feed value is subtracted from the tear off value. If the adjust value is over 1 inch, the micro reverse paper feed is not executed.

Auto loading position change mode

While holding down the LINE FEED button, press the SET/PARK/EJECT button. The printer enters the auto loading position change mode.

When the auto loading position change mode is entered, a short buzzer sounds twice, and all LEDs turn ON. If paper is loaded (not paper end condition), the paper is ejected when using cut-sheet paper or parked when using fanfold paper. If the paper is not parked or ejected completely, the printer exits from the auto loading position change mode, sounds a short buzzer three times, and sets the LEDs back to the previous condition. Below are the button assignments in auto loading position change mode.

Pressing the ON LINE button

If paper end condition, the printer executes paper loading.

If not paper end condition, the printer exits from the auto loading position change mode and ignores the change.

Holding down the ON LINE button and pressing the LINE FEED button

The printer exits from the auto loading position change mode, and the auto loading values are reset to factory default.

Holding down the ON LINE button and pressing the SET/PARK/EJECT button

The printer exits from the auto loading position change mode, and the change is effective until the next change (setting is kept in EEPROM).

Pressing the LINE FEED button

The printer executes micro forward paper feed, and the auto loading value is increased.

Pressing the SET/PARK/EJECT button

The printer executes micro reverse paper feed, and the auto loading value is decreased.

The auto loading value must be greater than 0 inch. If the auto loading value is less than 14/360 inch, the micro reverse paper feed is not executed.

A micro paper feed moves the paper by 1/60 inch. When the printer exits from the auto loading position change mode, a short buzzer sounds twice, and all LEDs return to their previous conditions.

Set top of form (TOF)

While holding down the SET/PARK/EJECT button, press the LINE FEED button. The vertical position is reset to the first line.

Buffer clear & All reset

While holding down the SET/PARK/EJECT button, press the ON LINE button. Keep both buttons held down until the printer beeps once to clear the data buffer. Continue to hold down both buttons until the printer beeps again three times to reset all the settings.

After releasing the buttons, the printer is initialized in the same way as a power-on reset.

4. Using the EDS Mode

EDS stand for Electronic DIP Switches. Just like the small DIP switches that are used by computers, printers, and other devices, the EDS lets you configure the printer for your application.

This chapter describes how to enter the printer's EDS Mode and provides details about available settings and how to change them.

About EDS Mode settings

The EDS Mode of this printer actually consists of five sub-modes, named EDS-1 to EDS-5. EDS settings are grouped among four "banks" (representing banks of switches) that are identified by the letters A through D. Each bank contains a number of "switches" numbered 1 through 7 that you can turn on and off to configure the printer.

Entering the EDS Mode

1. Make sure that paper is loaded in the printer.
2. Turn off the printer.
3. To enter the EDS Mode, turn the printer on while holding down the control panel's **LINE FEED**, and **ON LINE** buttons.

This causes the following message to be printed, which indicates the printer is in the EDS Mode.

CURRENT EDS SETTINGS

Bank	1-A	1-B	1-C	1-D	2-A	2-B	2-C	2-D	3-A	4-A	4-B	5-A	5-B
Switch	12	1234567	12345	1234567	123456	123456	123456	1234567	1234	1234	1234	1234	1234
ON	**	**	**	**	**	**	**	**	**	*	*	*	*
OFF		*								*	*	*	*

Bank : 1-A Switch : 1 ON

Selecting a EDS number

In the EDS Modes , use the control panel's **LINE FEED** button, while holding down **SET/PARK/EJECT** button to select a EDS number. When pressed the button, current setting of the bank is printed.

Selecting a bank

While in the EDS Modes , use the control panel's **SET/PARK/EJECT** button to select a bank. When pressed the button, current setting of the bank is printed.

Selecting a switch

While in the EDS Modes , use the control panel's **LINE FEED** button to select a switch. When pressed the button, current setting of the is switch printed.

Changing a switch setting

After selecting a bank and a switch, press the control panel's **ON LINE** button to turn the switch on and off. When pressed the button, changed setting of the switch is printed.

Printing the current EDS settings

While holding down **LINE FEED** button, press the control panel's **ON LINE** button to print out the current switch settings. Asterisks on the printout show whether a switch is turned on or off.

Exiting the EDS Modes

While holding down **SET/PARK/EJECT** button, press the control panel's **ON LINE** button to exit the EDS Modes.

Use the information in the following table to change the EDS settings.

< EDS-1 >

BANK	SW	FUNCTION	ON	OFF																												
A	1	(Reserved)																														
	2																															
	3																															
	4																															
	5																															
	6																															
	7																															
B	1	(Reserved)																														
	2																															
	3																															
	4																															
	5																															
	6																															
	7																															
C	1	Print mode	<table border="1"> <tr> <td>1</td> <td>2</td> <td></td> </tr> <tr> <td>ON</td> <td>ON</td> <td>LQ (x1) *</td> </tr> <tr> <td>OFF</td> <td>ON</td> <td>Draft (x3)</td> </tr> </table>		1	2		ON	ON	LQ (x1) *	OFF	ON	Draft (x3)																			
	1				2																											
	ON	ON	LQ (x1) *																													
	OFF	ON	Draft (x3)																													
	2																															
	3	Character pitch	<table border="1"> <tr> <td>3</td> <td>4</td> <td>5</td> <td></td> </tr> <tr> <td>ON</td> <td>ON</td> <td>ON</td> <td>10 CPI *</td> </tr> <tr> <td>ON</td> <td>ON</td> <td>OFF</td> <td>12 CPI</td> </tr> <tr> <td>ON</td> <td>OFF</td> <td>ON</td> <td>15 CPI</td> </tr> <tr> <td>ON</td> <td>OFF</td> <td>OFF</td> <td>17 CPI</td> </tr> <tr> <td>OFF</td> <td>ON</td> <td>ON</td> <td>20 CPI</td> </tr> <tr> <td>OFF</td> <td>ON</td> <td>OFF</td> <td>Proportional</td> </tr> </table>			3	4	5		ON	ON	ON	10 CPI *	ON	ON	OFF	12 CPI	ON	OFF	ON	15 CPI	ON	OFF	OFF	17 CPI	OFF	ON	ON	20 CPI	OFF	ON	OFF
3	4					5																										
ON	ON					ON	10 CPI *																									
ON	ON					OFF	12 CPI																									
ON	OFF	ON	15 CPI																													
ON	OFF	OFF	17 CPI																													
OFF	ON	ON	20 CPI																													
OFF	ON	OFF	Proportional																													
4																																
5																																
6	LQ Font	Roman*	Sanserif																													
D	1	Character table	IBM Graphics *	Italic																												
	2	Character set	#2 *	#1																												
	3	Zero style	Normal *	Slashed zero																												
	4	(Reserved)																														
	5																															
	6																															
	7																															

*: Default setting

Printer mode

The relation between the printer quality and the printer speed is as follows:

Printer quality LQ > Draft

Printer speed Draft > LQ

The values inside the parentheses are print speed ratios with respect to LQ.

Character table / IBM character set

See Appendix B, “Character set” for details.

< EDS-2 >

BANK	SW	FUNCTION	ON	OFF														
A	1	Input buffer	Large (54.5 K bytes) *	Small (1K byte)														
	2	Auto CR with LF	Enabled *	Disabled														
	3	Auto LF with CR	Disabled *	Enabled														
	4	Buzzer	Enabled *	Disabled														
	5	Saving Control Panel Status	Panel Macro *	Auto Saving														
	6	Quiet mode	Disabled *	Enabled														
B	1	Auto Tear-off	Disabled *	Enabled														
	2 3	Multi-part mode	<table border="1"> <tr> <td>2</td> <td>3</td> <td></td> </tr> <tr> <td>ON</td> <td>ON</td> <td>Auto selection *</td> </tr> <tr> <td>ON</td> <td>OFF</td> <td>Multi-part mode</td> </tr> <tr> <td>OFF</td> <td>ON</td> <td>Normal mode</td> </tr> </table>		2	3		ON	ON	Auto selection *	ON	OFF	Multi-part mode	OFF	ON	Normal mode		
	2		3															
	ON		ON	Auto selection *														
	ON		OFF	Multi-part mode														
	OFF	ON	Normal mode															
	4 5	Waiting period for Paper loading	<table border="1"> <tr> <td>4</td> <td>5</td> <td></td> </tr> <tr> <td>ON</td> <td>ON</td> <td>0.5 sec.</td> </tr> <tr> <td>ON</td> <td>OFF</td> <td>1.0 sec.</td> </tr> <tr> <td>OFF</td> <td>ON</td> <td>1.5 sec.</td> </tr> <tr> <td>OFF</td> <td>OFF</td> <td>2.0 sec.</td> </tr> </table>		4	5		ON	ON	0.5 sec.	ON	OFF	1.0 sec.	OFF	ON	1.5 sec.	OFF	OFF
4	5																	
ON	ON		0.5 sec.															
ON	OFF		1.0 sec.															
OFF	ON	1.5 sec.																
OFF	OFF	2.0 sec.																
6	75% Compress mode	Disabled *	Enabled															
C	1	Line spacing	1/6" *	1/8"														
	2	FF command	Eject *	Form Feed														
	3	Eject direction	Front *	Rear														
	4	Eject paper at Power ON	Enabled *	Disabled														
	5	Skip over perforation	Disabled *	Enabled														
	6	Paper out detector	Enabled *	Disabled														
D	1	Print direction	Bi-directional *	Uni-directional														
	2	Print direction command	Disabled *	Enabled														
	3	CR centering at top of form	Disabled *	Enabled														
	4	CR wiping at top/bottom	Disabled *	Enabled														
	5	2-pass printing at top/bottom	Disabled *	Enabled														
	6	Strobe timing	Normal *	Special														
	7	ACK timing	Normal *	Special														

*: Default setting

Auto CR with LF

When auto CR (carriage return) with LF (line feed) is enabled, the printer automatically performs a carriage return whenever it receives a LF code from the computer. This moves the print position to the beginning of the next line. If the printer adds an extra line after every carriage return, select OFF.

Auto LF with CR

When auto LF with CR is enabled (OFF), the printer automatically performs a line feed whenever it receives a CR code from the computer. When disabled (ON), the computer must send both a line feed code and a carriage return code at the end of each line. Most computers and applications send both.

Note the following check points when determining which setting to use.

- If you find that your output is double-spaced when it should not be, turn this switch ON (disabled).
- If you find that lines are printing over each other, turn this switch OFF (enabled).

Saving Control Panel Status

You can select either “Panel Macro” or “Auto Saving” to save the current control panel settings. See “Panel macro” on page 26.

Quiet mode

When the Quiet Mode is enabled (OFF), the printer prints with less noise than normal printing. Though the Quiet Mode prints more quietly, it also takes considerably longer than normal printing.

Auto Tear-off

Specifies whether the printer’s auto tear-off feature is enabled (OFF) or disabled (ON). Note that this setting controls the application software’s tear-off function only. It does not affect the manual tear-off function that is performed using the control panel buttons as described on page 25. The manual tear-off function is always enabled.

Multi-part mode

When the printer is in the Multi-part Mode, the print head prints with greater impact. It should be noted, however, that printing in the Multi-part Mode also reduces the life of the print head. Because of this, you should use the Multi-part Mode only for printing on four or five-ply paper. Use the Normal Mode for printing on one to three-ply paper. When Auto (SW2: ON, SW3: ON) is selected, the printer automatically switches between the Multi-part Mode and Normal Mode according to the adjustment lever position. The Normal Mode is automatically selected when the adjustment lever is at any setting of 3 or less, while the Multi-paper mode is selected for settings greater than 3.

Waiting period for Paper loading

This function sets the amount of wait time between paper insertion and paper feeding. If the paper feeds before you can adjust the paper position to your satisfaction, increase the wait time.

75% Compress mode

In the compression mode, the printer is able to receive print data for up to 10.6-inch printing width. The print data is compressed from 10.6 inches to 8 inches (compression ratio of 75%).

FF command / Eject direction

These functions are valid when the release lever is set to the cut-sheet paper position.

Eject paper at Power ON

This function is valid when the release lever is set to the cut-sheet paper position. This function selects whether to eject the cut-sheet paper when a cut-sheet paper is on the paper guide at power on.

Skip over perforation

This function is valid only when fanfold paper is selected. When enabled, the printer provides a one-inch margin between the last line printed on one page and the first line printed on the next page.

Print direction

This function selects bi-directional printing or uni-directional printing. Printing is normally bi-directional, but uni-directional printing allows for precise vertical printing alignment.

Print direction command

When disabled (ON), the preset printing direction overrides the print direction commands sent by your software.

CR centering at top of form

This function is used to improve the paper feed precision when inserting paper, ejecting paper, printing at the top or bottom edge of a paper, and printing near the perforation of a fanfold paper. CR centering refers to the operation of moving the carriage near the center of the paper. When enabled (OFF), the printer performs CR centering at the positions indicated above.

CR wiping at top/bottom

When enabled (OFF), the carriage moves to prevent a paper jam when the printer inserts or ejects a curled paper.

2-pass printing at top/bottom

This function performs 2-pass printing when printing within 1/6 inch of a perforation or 1/6 inch of the top or bottom edge of a paper. When enabled (OFF), the printer performs 2-pass printing to prevent a paper jam when printing at the positions indicated above.

Strobe timing

Selecting Normal (ON) allows the printer to receive data from the computer when the parallel interface's strobe signal falls. Selecting Special (OFF) allows data receipt when the strobe signal rises.

ACK timing

Specifies the relation between the ACK (acknowledge) timing and the BUSY timing. When set to Normal, the BUSY signal is activated while ACK is being output. When set to Special, the BUSY signal is activated after ACK is output.

< EDS-3>

BANK	SW	FUNCTION	ON				OFF	
			1	2	3	4		
A	1	International character set						
	2		ON	ON	ON	ON	U.S.A *	
	3		ON	ON	ON	OFF	France	
	4		ON	ON	OFF	ON	Germany	
			ON	ON	OFF	OFF	England	
			ON	OFF	ON	ON	Denmark-1	
			ON	OFF	ON	OFF	Sweden	
			ON	OFF	OFF	ON	Italy	
			ON	OFF	OFF	OFF	Spain-1	
			OFF	ON	ON	ON	Japan	
			OFF	ON	ON	OFF	Norway	
			OFF	ON	OFF	ON	Denmark-2	
			OFF	ON	OFF	OFF	Spain-2	
			OFF	OFF	ON	ON	Latin America	
			OFF	OFF	ON	OFF	Korea	
			OFF	OFF	OFF	ON	Ireland	
			OFF	OFF	OFF	OFF	Legal	
B	1	Code Page						
	2		ON	ON	ON	ON	ON	#437 U.S.A *
	3		ON	ON	ON	ON	OFF	#737 Greek
	4		ON	ON	ON	OFF	ON	#772 Lithuanian
	5		ON	ON	ON	OFF	OFF	#774 Lithuanian
			ON	ON	OFF	ON	ON	#850 Multi-lingual
			ON	ON	OFF	ON	OFF	#851 Greek
			ON	ON	OFF	OFF	ON	#852 Latin-2
			ON	ON	OFF	OFF	OFF	#858 Multi-lingual with Euro
			ON	OFF	ON	ON	ON	#860 Portuguese
			ON	OFF	ON	ON	OFF	#861 Icelandic
			ON	OFF	ON	OFF	ON	#863 Canada French
			ON	OFF	ON	OFF	OFF	#865 Nordic
			ON	OFF	OFF	ON	ON	#866 Russian
			ON	OFF	OFF	ON	OFF	#869 Greek
			ON	OFF	OFF	OFF	ON	#928 Greek
			ON	OFF	OFF	OFF	OFF	#1001 Arabic
			OFF	ON	ON	ON	ON	#2001 Lithuanian-KBL
			OFF	ON	ON	ON	OFF	#3001 Estonian-1
			OFF	ON	ON	OFF	ON	#3002 Estonian-2
			OFF	ON	ON	OFF	OFF	#3011 Latvian-1
			OFF	ON	OFF	ON	ON	#3012 Latvian-2
			OFF	ON	OFF	ON	OFF	#3021 Bulgarian
			OFF	ON	OFF	OFF	ON	#3031 Hebrew
			OFF	ON	OFF	OFF	OFF	#3041 Maltese
			OFF	OFF	ON	ON	ON	#3840 IBM-Russian
			OFF	OFF	ON	ON	OFF	#3841 Gost
			OFF	OFF	ON	OFF	ON	#3843 Polish
			OFF	OFF	ON	OFF	OFF	#3844 CS2
			OFF	OFF	OFF	ON	ON	#3845 Hungarian
			OFF	OFF	OFF	ON	OFF	#3846 Turkish
			OFF	OFF	OFF	OFF	ON	#3847 Brazil-ABNT
	OFF	OFF	OFF	OFF	OFF	#3848 Brazil-ABICOMP		

*: Default setting

International character set

See Appendix C, “Character set” for details.

Code page

A code page is the set of symbols and characters that your printer can print. Your printer converts ASCII hexadecimal data according to a code page to print symbols and characters. By supporting different code pages, the printer can print in a variety of different languages. The following table shows detailed information about code pages.

Code Page	Name	Country	Remarks
#437	U.S.A	United Kingdom, France, Germany, Italy, Austria, Switzerland, United States, Spain	
#737	Greek	Greece	Almost 80%
#772	Lithuanian	Lithuania	New standard
#774	Lithuanian	Lithuania	
#850	Multi-lingual	United Kingdom, France, Germany, Italy, Austria, Switzerland, United States, Spain	Preferred by Microsoft
#851	Greek	Greece	
#852	Latin-2	Croatia, Czech Republic, Hungary, Poland, Romania, Serbia, Slovak Republic, Slovenia	Preferred by Microsoft
#858	Multi-lingual with Euro		
#860	Portuguese	Portugal	
#861	Icelandic	Iceland	
#863	Canada French	Canada	
#865	Nordic	Denmark, Finland, Norway, Sweden	Preferred by Microsoft
#866	Russian	Russia	Preferred by Microsoft
#869	Greek	Greece	
#928	Greek	Greece	for UNIX
#1001	Arabic	Egypt, Saudi Arabia	Mainly in Arabic speaking countries
#2001	Lithuanian-KBL	Lithuania	Commonly used for DOS
#3001	Estonian-1	Estonia	
#3002	Estonian-2	Estonia	Most often used
#3011	Latvian-1	Latvia	
#3012	Latvian-2	Latvia	Government standard
#3021	Bulgarian	Bulgaria	
#3031	Hebrew	Israel	
#3041	Maltese	Malta	
#3840	IBM-Russian	Russia, Bulgaria	
#3841	Gost	Russia	Gost: government standard
#3843	Polish	Poland	Also called “Mazovia”
#3844	CS2	Czech Republic	Also called “Kamenicky”
#3845	Hungarian	Hungary	
#3846	Turkish	Turkey	
#3847	Brazil-ABNT		
#3848	Brazil-ABICOMP		

< EDS-4 >

BANK	SW	FUNCTION	ON				OFF
A	1	Page length (Cut-sheet paper)	1	2	3	4	
	2		ON	ON	ON	ON	-
	3		ON	ON	ON	OFF	-
	4		ON	ON	OFF	ON	3.5 inch
			ON	ON	OFF	OFF	11/3 inch
			ON	OFF	ON	ON	4.0 inch
			ON	OFF	ON	OFF	5.5 inch
			ON	OFF	OFF	ON	6.0 inch
			ON	OFF	OFF	OFF	7.0 inch
			OFF	ON	ON	ON	8.0 inch
			OFF	ON	ON	OFF	8.5 inch
			OFF	ON	OFF	ON	11.0 inch
			OFF	ON	OFF	OFF	11.7 inch / A4 *
			OFF	OFF	ON	ON	12.0 inch
	OFF	OFF	ON	OFF	14.0 inch		
	OFF	OFF	OFF	ON	(17.0 inch)		
B	1	Top margin (Cut-sheet paper)	1	2			
	2		ON	ON	1.0 mm (1-pin)		
			ON	OFF	1/6 inch * (1-pin)		
			OFF	ON	9.24 mm (1-pin)		
			OFF	OFF	1 inch (24-pin)		
	3	Bottom margin (Cut-sheet paper)	3	4			
	4		ON	ON	1.0 mm (24-pin)		
			ON	OFF	1/6 inch * (24-pin)		
			OFF	ON	1/2 inch (24-pin)		

*: Default setting

Page length (Cut-sheet paper)

The print quality for the values enclosed in parentheses (17.0 inch) is not guaranteed.

< EDS-5 >

BANK	SW	FUNCTION	ON				OFF
A	1	Page length (Fanfold paper)	1	2	3	4	
	2		ON	ON	ON	ON	(11/4 inch)
	3		ON	ON	ON	OFF	(3.0 inch)
	4		ON	ON	OFF	ON	(3.5 inch)
			ON	ON	OFF	OFF	(11/3 inch)
			ON	OFF	ON	ON	(4.0 inch)
			ON	OFF	ON	OFF	5.5 inch
			ON	OFF	OFF	ON	6.0 inch
			ON	OFF	OFF	OFF	7.0 inch
			OFF	ON	ON	ON	8.0 inch
			OFF	ON	ON	OFF	8.5 inch
			OFF	ON	OFF	ON	11.0 inch *
			OFF	ON	OFF	OFF	11.7 inch / A4
			OFF	OFF	ON	ON	12.0 inch
	OFF	OFF	ON	OFF	14.0 inch		
	OFF	OFF	OFF	ON	17.0 inch		
B	1	Top margin (Fanfold paper)	1	2			
	2		ON	ON	1.0 mm	(1-pin)	
			ON	OFF	1/6 inch *	(1-pin)	
			OFF	ON	9.24 mm	(1-pin)	
			OFF	OFF	1 inch	(24-pin)	
	3	Bottom margin (Fanfold paper)	3	4			
	4		ON	ON	1.0 mm	(24-pin)	
			ON	OFF	1/6 inch *	(24-pin)	
			OFF	ON	1/2 inch	(24-pin)	
			OFF	OFF	1 inch	(24-pin)	

*: Default setting

Page length (Fanfold paper)

The print quality for the values enclosed in parentheses (11/4 inch to 4.0 inch) are not guaranteed.

5. Control Codes List

< ESC/P mode >

Command	HEX code	Function
BEL	07	Beeper
BS	08	Backspace
HT	09	Tab horizontally
LF	0A	Line feed
VT	0B	Tab vertically
FF	0C	Form feed
CR	0D	Carriage return
SO	0E	Select Double-width printing (1 line)
SI	0F	Select Condensed printing
DC2	12	Cancel Condensed printing
DC4	14	Cancel Double-width printing (1 line)
CAN	18	Cancel line
DEL	7F	Delete last character in buffer
ESC SO	1B 0E	Select Double-width printing (1 line)
ESC SI	1B 0F	Select Condensed printing
ESC SP n	1B 20 n	Set inter character space
ESC ! n n = 00 01 02 04 08 10 20 40 80	1B 21 n n = 00 01 02 04 08 10 20 40 80	Master select 10 CPI (ESC P) 12 CPI (ESC M) Proportional (ESC p) Condensed (SI) Emphasized (ESC E) Double-strike (ESC G) Double-wide expanded (ESC W) Italic (ESC 4) Underlining (ESC -)
ESC #	1B 23	Cancel MSB control
ESC \$ n _l n _H	1B 24 n _l n _H	Set absolute horizontal print position
ESC % n n = 00 01	1B 25 n n = 00 01	Turn User-defined character on / off Turns User-defined character off Turns User-defined character on
ESC & 0 n m [a ₁ a ₂ d ...	1B 26 30 n m [a ₀ a ₁ a ₂ d ...	Define User-defined characters
ESC (- n _l n _H m d ₁ d ₂	1B 28 2D n _l n _H m d ₁ d ₂	Select or cancel score
ESC (B n _l n _H k m s v ₁ v ₂	1B 28 42 n _l n _H k m s v ₁ v ₂	Select Bar-code printing
ESC * m n _l n _H d ₁ ...d _k	1B 2A m n _l n _H d ₁ ...d _k	Select Bit-image mode
ESC + n	1B 2B n	Set n/360" line spacing
ESC - n n = 00 01	1B 2D n n = 00 01	Turn under lining mode on / off Turns underline off Turns underline on
ESC / n	1B 2F n	Select vertical tab channel
ESC 0	1B 30	Select 1/8" line spacing
ESC 2	1B 32	Select 1/6" line spacing
ESC 3 n	1B 33 n	Select n/180" line spacing
ESC 4	1B 34	Select italic font
ESC 5	1B 35	Cancel italic font
ESC 6	1B 36	Enable printing of upper control codes (Character set #2)
ESC 7	1B 37	Enable upper control codes (Character set #1)
ESC 8	1B 38	Disable paper out detector
ESC 9	1B 39	Enable paper out detector

ESC : 0 n 0	1B 3A 30 n 30	Copy standard character ROM font into RAM
ESC <	1B 3C	Select Unidirectional mode (1 line)
ESC =	1B 3D	Set MSB to 0
ESC >	1B 3E	Set MSB to 1
ESC ? n m	1B 3F n m	Reassign Bit-image mode
ESC @	1B 40	Initialize Printer
ESC A n	1B 41 n	Set n/60" line spacing
ESC B d ₁ ...d _k NUL	1B 42 d ₁ ...d _k 00	Set vertical tab
ESC C n	1B 43 n	Set page length in lines
ESC C NUL n	1B 43 00 n	Set page length in inches
ESC D n ₁ ...n _k NUL	1B 44 n ₁ ...n _k 00	Set horizontal tab
ESC E	1B 45	Select Bold mode
ESC F	1B 46	Cancel Bold mode
ESC G	1B 47	Select Double-strike printing
ESC H	1B 48	Cancel Double-strike printing
ESC J n	1B 4A n	Advance print position vertically (n/180")
ESC K n ₁ n _H d ₁ ...d _k	1B 4B n ₁ n _H d ₁ ...d _k	Select Single-density Bit-image mode
ESC L n ₁ n _H d ₁ ...d _k	1B 4C n ₁ n _H d ₁ ...d _k	Select Double-density Bit-image mode
ESC M	1B 4D	Select 12 CPI (Elite)
ESC N n	1B 4E n	Set Skip over perforation
ESC O	1B 4F	Cancel Skip over perforation
ESC P	1B 50	Select 10 CPI (Pica)
ESC Q n	1B 51 n	Set right margin
ESC R n	1B 52 n	Select international character set
n = 00	n = 00	#0 U.S.A.
01	01	#1 France
02	02	#2 Germany
03	03	#3 England
04	04	#4 Denmark I
05	05	#5 Sweden
06	06	#6 Italy
07	07	#7 Spain I
08	08	#8 Japan
09	09	#9 Norway
0A	0A	#10 Denmark II
0B	0B	#11 Spain II
0C	0C	#12 Latin America
0D	0D	#13 Korea
0E	0E	#14 Ireland
40	40	#64 Legal
ESC S n	1B 53 n	Select Superscript / Subscript printing
n = 00	n = 00	Superscript
01	01	Subscript
ESC T	1B 54	Cancel Superscript / Subscript printing
ESC U n	1B 55 n	Turn Unidirectional mode on / off
n = 00	n = 00	Bi-directional
01	01	Unidirectional
ESC W n	1B 57 n	Turn Double-width printing on / off
n = 00	n = 00	Turns off double-width
01	01	Turns on double-width
ESC Y n _L n _H d ₁ ...d _k	1B 59 n _L n _H d ₁ ...d _k	Select High-speed Double-density Bit-image mode
ESC Z n ₁ n _H d ₁ ...d _k	1B 5A n ₁ n _H d ₁ ...d _k	Select Quadruple-density Bit-image mode
ESC \ n _L n _H	1B 5C n _L n _H	Move relative horizontal print position
ESC b m n ₁ ...n _k NUL	1B 62 m n ₁ ...n _k 00	Set vertical tab in VFU channels
ESC g	1B 67	Select 15 CPI
ESC j n	1B 6A n	Advance reverse feed (n/180")

ESC k n n = 00 01 05	1B 6B n n = 00 01 05	Select Type style family Roman Sanserif OCR B
ESC l n	1B 6C n	Set left margin
ESC p n n = 00 01	1B 70 n n = 00 01	Turn proportional mode on / off Returns to current fixed character pitch Selects proportional spacing
ESC q n n = 00 01 02 03	1B 71 n n = 00 01 02 03	Select character style Cancel shadow / outline printing Set outline printing Set shadow printing Set shadow & outline printing
ESC s n n = 00 01	1B 73 n n = 00 01	Select quiet mode Prints at normal speed Prints at low speed
ESC t n n = 00 01 02 03	1B 74 n n = 00 01 02 03	Select character table Select italic character table Select Codepage character table Select Download character table Select Codepage character table
ESC w n n = 00 01	1B 77 n n = 00 01	Turn Double-high printing mode on / off Turns off double-high Turns on double-high
ESC x n n = 00 01	1B 78 n n = 00 01	Select print mode (ANK) Draft LQ

6. Troubleshooting

The appendix will provide help if you experience problems with your printer. It tells you how to test the printer, how to check system software settings, and how to adjust the vertical alignment. In addition, there is information on actions to take for specific problems, and on the meanings of printer beep tones.

Warning!

The printer uses high voltage. Do not attempt any other repair or maintenance except as expressly recommended in this appendix. Unauthorized repair and maintenance not only exposes you to the danger of electrical shock, it also may damage your printer and void your warranty.

Short test

Use the following procedure to test the printer to make sure that everything is working correctly.

1. Make sure that paper is loaded in the printer.
2. Turn off the printer.
3. While holding down the control panel's ON LINE button, turn the printer back on.
4. The short self-test prints the following information.
 - 1) The version number of the software contained in the printer's ROM.
 - 2) All EDS settings.

If there is no paper at power on, self-printing starts after the paper is loaded by the panel. In self-printing, only paper end detection is available. All panel functions are ignored. After self-printing finishes, the printer will reset.

Long test

Use the following procedure to test the printer to make sure that everything is working correctly.

1. Make sure that paper is loaded in the printer.
2. Turn off the printer.
3. While holding down the control panel's LINE FEED button, turn the printer back on.
4. The short self-test prints the following information.
 - 1) Rolling ASCII 7 lines.
 - 2) All ASCII characters.
Draft 10 cpi, 12 cpi, and 15 cpi
ROMAN 10 cpi, 12 cpi, and 15 cpi
 - 3) All Kanji characters.

Note:

Test printing prints across the entire width of the carriage. Make sure that the printer is loaded with the widest paper available in order to avoid damage to the print head and platen.

Hexadecimal dump

This procedure prints in hexadecimal format all codes (character codes and control codes) that are sent to the printer by the computer. The printer does not execute any control codes (such as 0A - linefeed), it just prints them out. The hexadecimal dump is useful when you are writing programs for printer control.

1. Make sure that paper is loaded in the printer.
2. Turn off the printer.
3. While holding down the control panel's SET/PARK/EJECT button, turn the printer back on to enter the Hex Dump Mode.
4. To exit the Hex Dump Mode, turn the printer off.

Adjusting the dot alignment

You may never have to use the procedure described in this section, but after you have been using your printer for some time you may find that the dots of some graphics do not align correctly. For example, what should look like:



may come out looking like one of the following:

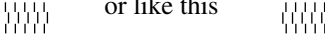

This is caused when mechanical parts of the printer get out of alignment. This happens only rarely and you may never experience it at all throughout the life of the printer. If you do have problems, use the following procedure to correct it.

1. Make sure that paper is loaded in the printer.
2. Turn off the printer.
3. While holding down the control panel's SET/PARK/EJECT and LINE FEED buttons, turn the printer back on to enter the Dot Adjustment Mode.

```
The printer will print something like the following.  
*** DOT ADJUSTMENT SETTING (Normal Mode) ***  
*  
Normal-density + 3 | | | | |
```

Note that the printer will feed the paper forward and back each time during this operation so you can view the printout.

4. If the two lines do not align properly, use SET/PARK/EJECT to move the lower line to the left or LINE FEED to move it to the right.

The above step performs alignment for Normal-density mode only. You must make separate adjustments for the CRT graphics, Double-density, Draft-Text, Triple-density, CRT graphics II, Quadruple-density, LQ Text modes as well.

5. Press ON LINE to change to the next printing mode.
Press LINE FEED while holding down ON LINE to change to the previous printing mode.
6. Repeat the above steps for each printing mode, if necessary.
7. After making changes to the adjustments, press SET/PARK/EJECT while holding down ON LINE to exit the Dot Adjustment Mode and register your adjustments.

Troubleshooting guide

Use the following table to help track down the causes of problems and to determine the best solution to deal with them.

Problem	Possible Cause	Recommended Action
The ON LINE indicator does not light.	The printer is not receiving power.	Check whether the power cord is correctly plugged into the power outlet.
		Check whether the power outlet is working by unplugging the printer and plugging in another device.
Printer sounds like it is printing, but it is not. Printing is weak.	The ribbon is jammed, twisted, or not set correctly between the print head and the print head shield.	Make sure that the ribbon cassette is installed correctly.
	The printer is not set up correctly for the thickness of paper you are using.	Set up the printer for the paper thickness you are using. See "Adjusting for paper thickness table" on page 15.
	The ribbon is worn out or "used up."	Replace the ribbon with a new one.
Printer test works, but printer will not print out data from the attached computer.	Your application program's or system software's printer selection is wrong.	Check the printer selection of your application software.
	The computer's system software is not set up properly for the printer or for the port you are using.	Check the system software settings. Check the settings for LPT1.
Printer test works, but printer will not print out data from the attached computer.	The interface cable is connected incorrectly or damaged.	Check to make sure that the printer interface cable is connected correctly. If it is, try a different cable.
Printer does not feed paper properly.	Jamming paper.	Remove all paper from the printer and then reload it.
	The printer is not set up correctly for the thickness of paper being used.	Set up the printer for the paper thickness you are using. See "Adjusting for paper thickness table" on page 15.

Problem	Possible Cause	Recommended Action
Line spacing is incorrect.	Jamming paper.	Set up the printer for the paper thickness you are using. See "Adjusting for paper thickness table" on page 15.
	The line spacing or leading selected in your application program is wrong.	Choose a different line spacing or leading setting from your application.
	Auto line feed with carriage return is enabled.	Use the EDS Mode to disable auto line feed with carriage return (page 32).
Lines print over each other.	Auto line feed with carriage return is disabled.	Use the EDS Mode to disable auto line feed with carriage return (page 32).
	Jamming paper.	Set up the printer for the paper thickness you are using. See "Adjusting for paper thickness table" on page 15.
Incorrect number of lines are printed on the page.	Auto line feed with carriage return is enabled.	Use the EDS Mode to disable auto line feed with carriage return (page 32).
	The line spacing or leading selected by your application program is wrong.	Choose a different line spacing or leading setting from your application.
	Dot adjustment is not correct.	See "Adjusting the dot alignment" on page 47.
Text and graphics are malformed. Print quality is poor.	The ribbon is worn out or "used up".	Replace the ribbon with a new one.
	The printer is not set up correctly for the thickness of paper being used.	Set up the printer for the paper thickness you are using. See "Adjusting for paper thickness table" on page 15.
	The print head is damaged.	Return the printer to your dealer for repair.
Forms are smudged. Printing is too dark.	The printer is not set up correctly for the thickness of paper being used.	Set up the printer for the paper thickness you are using. See "Adjusting for paper thickness table" on page 15.
	The ribbon is jammed, twisted, or not set correctly between the print head and the print head shield.	Make sure that the ribbon cassette is installed correctly. See "Installing the ribbon cassette" on page 7.
	Print head shield is damaged or missing.	Return the printer to your dealer for repair.

Problem	Possible Cause	Recommended Action
Printer case is hot.	The printer's air vents are blocked or obstructed.	Switch off the printer and let it cool. Check the air vents on the bottom of the printer to see if they are blocked. Remove the obstruction if possible. If the problem persists, return the printer to your dealer for repair.
Printer makes excessive noise.	The printer cover is removed.	Replace the printer cover.
	The printer is vibrating.	Move any objects that are touching the printer.
		Make sure that the printer is on a level steady surface.
Printer prints past the edge of the paper.	Incorrect margin settings are selected by your application program.	Choose different margin settings from your application program.
	The paper edge is not positioned correctly.	Remove the paper and adjust the position of the paper edge. Reload the paper and try printing again.
	The ribbon is jammed, causing the print head to jam.	Make sure that the ribbon cassette is installed correctly. See "Installing the ribbon cassette" on page 7.
	Paper is jamming, causing the print head to jam.	Remove all paper from the printer and reload it. Try printing again.
Set up the printer for the paper thickness you are using. See "Adjusting for paper thickness table" on page 15.		

Problem	Possible Cause	Recommended Action
Left margin moves to the right during printing.	The paper is not loaded correctly, causing the print head to jam.	Remove all paper from the printer and reload it. Try printing again.
	The ribbon cassette is not installed correctly, causing the print head to jam.	Make sure that the ribbon cassette is installed correctly. See "Installing the ribbon cassette" on page 7.
	The printer is not set up correctly for the thickness of paper being used.	Set up the printer for the paper thickness you are using. See "Adjusting for paper thickness table" on page 15.
	Inappropriate settings are selected by your application program.	Choose different settings in your application.
	Static electricity caused by interference from nearby electrical devices or by low-level humidity is affecting printer operation.	Make sure that the printer is not too close to any devices with electric motors or that raise the humidity level.
Some characters are printed incorrectly.	Panel Lock Mode is enabled.	Turn off the printer, and then turn it back on.
	Panel Lock Mode is enabled. Panel Macro Mode is also enabled.	While holding down SET/PARK/EJECT button, press ON LINE button to clear Panel Macro Mode. After three buzzer sounds, turn off the printer, and then turn it back on.
	The wrong character table, code page, or international character set is selected.	Use the EDS Mode to select the correct character table, code page, or international character set (page 34).
	Static electricity caused by interference from nearby electrical devices or by low-level humidity is affecting printer operation.	Make sure that the printer is not too close to any devices with electric motors or that raise the humidity level.

Problem	Possible Cause	Recommended Action
Some characters are printed incorrectly.	Inappropriate settings are selected by your application program.	Choose different settings in your application.
	Wires are missing from the print head.	Return the printer to your dealer for repair.
Printer behaves erratically. Printing suddenly stops.	The interface cable is connected incorrectly or damaged.	Check to make sure that the printer interface cable is connected correctly. If it is, try a different cable.
	Static electricity caused by interference from nearby electrical devices or by low-level humidity is affecting printer operation.	Make sure that the printer is not too close to any devices with electric motors or that raise the humidity level.

Appendix A: Specifications

Printing System	Serial Impact Dot-Matrix																		
Printing Speed (Character per Sec.) (When using Normal mode)	<table border="0" style="width: 100%;"> <tr> <td style="width: 30%;"></td> <td style="text-align: center;">Draft</td> <td style="text-align: center;">LQ</td> </tr> <tr> <td>10CPI</td> <td style="text-align: center;">180</td> <td style="text-align: center;">60</td> </tr> <tr> <td>12CPI</td> <td style="text-align: center;">216</td> <td style="text-align: center;">72</td> </tr> <tr> <td>15CPI</td> <td style="text-align: center;">270</td> <td style="text-align: center;">90</td> </tr> <tr> <td>17.1CPI</td> <td style="text-align: center;">154</td> <td style="text-align: center;">103</td> </tr> <tr> <td>20CPI</td> <td style="text-align: center;">180</td> <td style="text-align: center;">120</td> </tr> </table>		Draft	LQ	10CPI	180	60	12CPI	216	72	15CPI	270	90	17.1CPI	154	103	20CPI	180	120
	Draft	LQ																	
10CPI	180	60																	
12CPI	216	72																	
15CPI	270	90																	
17.1CPI	154	103																	
20CPI	180	120																	
Print Direction	<p>Draft: Uni-directional/ bi-directional logic seeking (selectable)</p> <p>LQ: Uni-directional/ bi-directional logic seeking (selectable)</p> <p>Bit-Image: Uni-directional/ bi-directional logic seeking (selectable)</p>																		
Print Head Life	<p>Number of pins: 24</p> <p>200 million dots/pin (adjustment lever position 1 to 3)</p> <p>100 million dots/pin (adjustment lever position 4 to 8)</p>																		
Line Spacing Environment	<p>1/6, 1/8, n/60, n/180, n/360</p> <p>Operating temperature: 41°F to 95°F (5°C to 35°C)</p> <p>Storage temperature: -22°F to 149°F (-30°C to 65°C)</p> <p>Operating humidity: 30% to 80% (non-condensing)</p> <p>Storage humidity: 20% to 90% (non-condensing)</p>																		
Emulation Interfaces	ESC/P																		
Ribbon Type	<p>Parallel Bi-directional IEEE-1284 nibble mode</p> <p>On-carriage, dedicated</p> <p>Black ribbon</p> <p>CS24 (Standard)</p>																		
Ribbon Life	4.0 million characters (Draft, 10CPI)																		
Dimensions and Weight	<p>Width: 14.3" / 363 mm</p> <p>Depth: 9.6" / 244 mm</p> <p>Height: 8.1" / 205 mm</p> <p>Weight: 13.0lbs. / 5.9 kg</p>																		
Power Supply	220V±15% 50/60Hz																		
Power Consumption	<p>55W during ASCII draft printing</p> <p>10W during stand-by</p>																		

Paper

Cut-sheet paper

Width:	125 to 257 mm / 4.9 to 10.12 inches
Length:	85 to 364 mm / 3.3 to 14.33 inches
Paper Sizes:	A6: 105 x 148 mm (Landscape)
	B6: 128.5 x 182 mm (Portrait, Landscape)
	A5: 148 x 210 mm (Portrait, Landscape)
	B5: 182 x 257 mm (Portrait, Landscape)
	A4: 210 x 297mm (Portrait)
	B4: 257 x 364mm (Portrait)
	Executive: 7.25 x 10.5 inches (Portrait)
	Letter: 8.5 x 11 inches (Portrait)
	Legal: 8.5 x 14 inches (Portrait)

Thickness

1-ply only:	0.05 to 0.18 mm
Multi-ply:	0.05 to 0.35 mm

Weight

1-ply only:	52 to 156 g/m ² / 14 to 42 lbs / 45 to 135kg
Multi-ply:	40 to 52 g/m ² / 11 to 14 lbs / 34 to 45kg

Fanfold paper

Width:	139.7 to 254 mm / 5.5 to 10 inches
Length: Min.	139.7 mm / 5.5 inches

Thickness

1-ply only:	0.07 to 0.11 mm
Multi-ply:	Max. 0.35 mm

Weight

1-ply only:	52 to 82 g/m ² / 14 to 22 lbs / 45 to 70kg
Multi-ply:	40 to 52 g/m ² / 11 to 14 lbs / 34 to 45kg

Parallel Interface

Connector Signals

Pin	Name	Function
1	STROBE	Goes low for $\geq 0.5\mu\text{s}$ when active.
2	DATA0	These signals represent information for the 1st through 8th bit of parallel data, respectively. Each signal is HIGH when data is logical 1, and LOW when logical 0.
3	DATA1	
4	DATA2	
5	DATA3	
6	DATA4	
7	DATA5	
8	DATA6	
9	DATA7	
10	$\overline{\text{ACK}}$	10 μs low to acknowledge receipt of data.
11	BUSY	Printer sets line low when ready to receive data.
12	PAPER	High when paper runs out.
13	SELECT	High when printer is on-line.
14	$\overline{\text{AFXT}}$	This signal is used when the mode is nibble mode.
15		Not used.
16	SIGNAL GND	Signal ground
17	CHASSIS	Chassis ground (isolated from signal ground)
18	+5V	+5V DC output from printer
19~30	GND	Twisted pair ground return
31	$\overline{\text{RESET}}$	Printer is reset when this signal goes low.
32	$\overline{\text{ERROR}}$	Low when printing cannot continue due to error.
33	EXT GND	External ground
34~35		Not used
36	$\overline{\overline{\text{SELECT IN}}}$	This signal is used when the mode is nibble mode.

Appendix B: Character Sets

IBM Graphics Character Set #2 Code Page #437 (U.S.A.)

	0	1	2	3	4	5	6	7	8	9	A	B	C	D	E	F
0	<NUL>		0	@	P	`	p	Ç	É	á	█	█	L	ll	α	≡
1		<DC1>	!	1	A	Q	a	q	ü	æ	í	█	┘	┘	β	±
2		<DC2>	"	2	B	R	b	r	é	Æ	ó	█	┘	┘	Γ	≥
3		<DC3>	#	3	C	S	c	s	â	ò	ú		┘	┘	π	≤
4		<DC4>	\$	4	D	T	d	t	ä	ö	ñ	┘	┘	┘	Σ	∫
5			%	5	E	U	e	u	à	ò	Ñ	┘	┘	┘	σ	∫
6			&	6	F	V	f	v	â	ù	á	┘	┘	┘	μ	+
7	<BEL>		'	7	G	W	g	w	ç	ù	ó	┘	┘	┘	τ	≈
8	<BS>	<CAN>	(8	H	X	h	x	ê	ÿ	¿	┘	┘	┘	Φ	°
9	<HT>)	9	I	Y	i	y	ë	Ö	┐	┘	┘	┘	Θ	•
A	<LF>		*	:	J	Z	j	z	è	Ü	┐	┘	┘	┘	Ω	•
B	<VT>	<BSC>	+	;	K	[k	{	ï	φ	½	┘	┘	█	δ	√
C	<PF>	<PS>	,	<	L	\	l	!	î	£	¼	┘	┘	┘	ø	n
D	<CR>		-	=	M]	m	}	i	¥	;	┘	┘	┘	∅	2
E	<SO>		.	>	N	^	n	~	Ä	Ð	«	┘	┘	┘	€	■
F	<SI>		/	?	O	_	o		A	f	»	┘	┘	┘	∅	∅

Italic Character Set #2

	0	1	2	3	4	5	6	7	8	9	A	B	C	D	E	F
0	<NUL>		0	@	P	`	p	<NUL>		0	@	P	`	p		
1		<DC1>	!	1	A	Q	a	q	<DC1>	!	1	A	Q	a	q	
2		<DC2>	"	2	B	R	b	r	<DC2>	"	2	B	R	b	r	
3		<DC3>	#	3	C	S	c	s	<DC3>	#	3	C	S	c	s	
4		<DC4>	\$	4	D	T	d	t	<DC4>	\$	4	D	T	d	t	
5			%	5	E	U	e	u		%	5	E	U	e	u	
6			&	6	F	V	f	v		&	6	F	V	f	v	
7	<BEL>		'	7	G	W	g	w	<BEL>	'	7	G	W	g	w	
8	<BS>	<CAN>	(8	H	X	h	x	<BS>	<CAN>	(8	H	X	h	x
9	<HT>)	9	I	Y	i	y	<HT>)	9	I	Y	i	y
A	<LF>		*	:	J	Z	j	z	<LF>	*	:	J	Z	j	z	
B	<VT>	<BSC>	+	;	K	[k	{	<VT>	<BSC>	+	;	K	[k	{
C	<PF>	<PS>	,	<	L	\	l	!	<PF>	<PS>	,	<	L	\	l	!
D	<CR>		-	=	M]	m	}	<CR>		-	=	M]	m	}
E	<SO>		.	>	N	^	n	~	<SO>		.	>	N	^	n	~
F	<SI>		/	?	O	_	o		<SI>		/	?	O	_	o	

IBM Graphics Character Set #1

	0	1	2	3	4	5	6	7	8	9	A	B	C	D	E	F
0	<NUL>		0	@	P	`	p	<NUL>		á	⌘	⌘	⌘	⌘	α	≡
1	<DC1>	!	1	A	Q	a	q	<DC1>	í	⌘	⌘	⌘	⌘	⌘	β	±
2	<DC2>	"	2	B	R	b	r	<DC2>	ó	⌘	⌘	⌘	⌘	⌘	Γ	≥
3	<DC3>	#	3	C	S	c	s	<DC3>	ú	⌘	⌘	⌘	⌘	⌘	π	≤
4	<DC4>	\$	4	D	T	d	t	<DC4>	ñ	⌘	⌘	⌘	⌘	⌘	Σ	∫
5		%	5	E	U	e	u		Ñ	⌘	⌘	⌘	⌘	⌘	σ	∫
6		&	6	F	V	f	v	<SYN>	á	⌘	⌘	⌘	⌘	⌘	μ	+
7	<BEL>	'	7	G	W	g	w	<BEL>	ó	⌘	⌘	⌘	⌘	⌘	τ	≈
8	<BS> <CAN>	(8	H	X	h	x	<BS> <CAN>	¿	⌘	⌘	⌘	⌘	⌘	Φ	°
9	<HT>)	9	I	Y	i	y	<HT> 	¡	⌘	⌘	⌘	⌘	⌘	Θ	•
A	<LF>	*	:	J	Z	j	z	<LF>	¡	⌘	⌘	⌘	⌘	⌘	Ω	•
B	<VT> <BSC>	+	;	K	[k	{	<VT> <BSC>	¿	⌘	⌘	⌘	⌘	⌘	δ	√
C	<PF> <PS>	,	<	L	\	l		<PF> <PS>	¿	⌘	⌘	⌘	⌘	⌘	∞	n
D	<CR>	-	=	M]	m	}	<CR>	¡	⌘	⌘	⌘	⌘	⌘	∅	z
E	<SO>	.	>	N	^	n	~	<SO>	«	⌘	⌘	⌘	⌘	⌘	ε	■
F	<SI>	/	?	O	_	o		<SI>	»	⌘	⌘	⌘	⌘	⌘	∩	

Italic Character Set #1

	0	1	2	3	4	5	6	7	8	9	A	B	C	D	E	F
0	<NUL>		0	@	P	`	p	<NUL>		0	@	P	`	p		
1	<DC1>	!	1	A	Q	a	q	<DC1>	!	1	A	Q	a	q		
2	<DC2>	"	2	B	R	b	r	<DC2>	"	2	B	R	b	r		
3	<DC3>	#	3	C	S	c	s	<DC3>	#	3	C	S	c	s		
4	<DC4>	\$	4	D	T	d	t	<DC4>	\$	4	D	T	d	t		
5		%	5	E	U	e	u		%	5	E	U	e	u		
6		&	6	F	V	f	v		&	6	F	V	f	v		
7	<BEL>	'	7	G	W	g	w	<BEL>	'	7	G	W	g	w		
8	<BS> <CAN>	(8	H	X	h	x	<BS> <CAN>	(8	H	X	h	x		
9	<HT>)	9	I	Y	i	y	<HT>)	9	I	Y	i	y		
A	<LF>	*	:	J	Z	j	z	<LF>	*	:	J	Z	j	z		
B	<VT> <BSC>	+	;	K	[k	{	<VT> <BSC>	+	;	K	[k	{		
C	<PF> <PS>	,	<	L	\	l		<PF> <PS>	,	<	L	\	l			
D	<CR>	-	=	M]	m	}	<CR>	-	=	M]	m	}		
E	<SO>	.	>	N	^	n	~	<SO>	.	>	N	^	n	~		
F	<SI>	/	?	O	_	o		<SI>	/	?	O	_	o			

Code Page #737
Greek

	8	9	A	B	C	D	E	F
0	Α	Ρ	ι	⋯	Λ	μ	ω	Ω
1	Β	Σ	κ	⋯	⊥	τ	ά	±
2	Γ	Τ	λ	⋯	⊥	π	έ	≥
3	Δ	Υ	μ		⊥	π	ή	≤
4	Ε	Φ	ν	⊥	⊥	ε	ι	Υ
5	Ζ	Χ	ξ	⊥	⊥	ϛ	ι	Υ
6	Η	Ψ	ο	⊥	⊥	π	ό	÷
7	Θ	Ω	π	⊥	⊥	π	ύ	≈
8	Ι	α	ε	⊥	⊥	π	ü	°
9	Κ	β	σ	⊥	⊥	π	ώ	•
A	Λ	γ	ς	⊥	⊥	π	Α	•
B	Μ	δ	τ	⊥	⊥	π	Ε	√ _n
C	Ν	ε	υ	⊥	⊥	π	Η	2
D	Ξ	ς	φ	⊥	⊥	π	Ι	■
E	Ο	η	χ	⊥	⊥	π	Ο	■
F	Π	θ	ψ	⊥	⊥	π	Υ	■

Code Page #772
Lithuanian

	8	9	A	B	C	D	E	F
0	А	Р	а	⋯	Л	а	р	Ё
1	Б	С	б	⋯	⊥	с	с	ё
2	В	Т	в	⋯	⊥	т	т	≥
3	Г	У	г		⊥	у	у	≤
4	Д	Ф	д	⊥	⊥	ф	„	“
5	Е	Х	е	⊥	⊥	х	“	“
6	Ж	Ц	ж	⊥	⊥	ц	÷	÷
7	З	Ч	з	⊥	⊥	ч	≈	≈
8	И	Ш	и	⊥	⊥	ш	°	°
9	Й	Щ	й	⊥	⊥	щ	•	•
A	К	Ь	к	⊥	⊥	ь	•	•
B	Л	Ы	л	⊥	⊥	ы	√ _n	√ _n
C	М	Ь	м	⊥	⊥	ь	2	2
D	Н	Э	н	⊥	⊥	э	■	■
E	О	Ю	о	⊥	⊥	ю	■	■
F	П	Я	п	⊥	⊥	я	■	■

Code Page #774
Lithuanian

	8	9	A	B	C	D	E	F
0	Ç	É	á	⋯	Л	а	α	≡
1	ü	æ	í	⋯	⊥	с	β	±
2	é	Æ	ó	⋯	⊥	е	Γ	≥
3	â	ð	ú		⊥	é	π	≤
4	ä	ö	ñ	⊥	⊥	í	Σ	„
5	à	ò	Ñ	⊥	⊥	š	σ	“
6	â	û	æ	⊥	⊥	ų	μ	÷
7	ç	ù	ø	⊥	⊥	ū	τ	≈
8	ê	ÿ	ı	⊥	⊥	ž	φ	°
9	ë	ÿ	ı	⊥	⊥	ž	θ	•
A	è	Û	ı	⊥	⊥	ž	Ω	•
B	ï	φ	½	⊥	⊥	■	δ	√ _n
C	î	£	¼	⊥	⊥	■	∞	2
D	ï	¥	ı	⊥	⊥	■	∅	■
E	Ë	ŕ	«	⊥	⊥	■	ε	■
F	À	f	»	⊥	⊥	■	∩	■

Code Page #850
Multi-lingual

	8	9	A	B	C	D	E	F
0	Ç	É	á	⋯	Л	ð	ó	-
1	ü	æ	í	⋯	⊥	Ð	β	±
2	é	Æ	ó	⋯	⊥	Ð	ò	=
3	â	ð	ú		⊥	Ð	ò	¾
4	ä	ö	ñ	⊥	⊥	Ð	ö	¾
5	à	ò	Ñ	⊥	⊥	Ð	ö	¾
6	â	û	æ	⊥	⊥	Ð	ö	¾
7	ç	ù	ø	⊥	⊥	Ð	ö	¾
8	ê	ÿ	ı	⊥	⊥	Ð	ö	¾
9	ë	ÿ	ı	⊥	⊥	Ð	ö	¾
A	è	Û	ı	⊥	⊥	Ð	ö	¾
B	ï	φ	½	⊥	⊥	Ð	ö	¾
C	î	£	¼	⊥	⊥	Ð	ö	¾
D	ï	¥	ı	⊥	⊥	Ð	ö	¾
E	Ë	ŕ	«	⊥	⊥	Ð	ö	¾
F	À	f	»	⊥	⊥	Ð	ö	¾

Other characters are the same as those for Code Page #437.

Code Page #851
Greek

	8	9	A	B	C	D	E	F
0	Ç	Ι	Ϛ	⋯	Λ	Τ	Ξ	-
1	ü		ϛ	⋯	⊥	Υ	η	±
2	é	Ο	ό	⋯	⊥	Φ	θ	υ
3	â	δ	ύ		⊥	Χ	υ	φ
4	ä	ö	Α	⊥	-	Ψ	κ	χ
5	à	Υ	Β	Κ	+	Ω	λ	ς
6	À	ú	Γ	Λ	Π	α	μ	ψ
7	ç	ù	Δ	Μ	Ρ	β	ν	.
8	ê	Ω	Ε	Ν	⊥	γ	ξ	°
9	ë	Ö	Ζ	⊥	⊥	⊥	ο	°
A	è	Û	Η	⊥	⊥	⊥	π	ω
B	ï	á	½	⊥	⊥	■	ρ	ü
C	î	£	⊕	⊥	⊥	■	σ	Û
D	E	é	Ι	Ε	⊥	■	ς	Ω
E	Ä	ñ	«	Ο	⊥	■	τ	'
F	H	í	»	⊥	Σ	■		

Code Page #852
Latin-2

	8	9	A	B	C	D	E	F
0	Ç	É	á	⋯	⊥	đ	Ó	-
1	ü	Ĺ	í	⋯	⊥	Đ	Ó	"
2	é	Í	ó	⋯	⊥	Đ	Ó	˘
3	â	δ	ú		⊥	Đ	Ó	˙
4	ä	ö	Α	⊥	-	đ	ń	˘
5	à	Υ	á	⊥	+	Đ	ň	š
6	À	ú	Ž	⊥	+	Đ	š	÷
7	ç	ù	ž	⊥	+	đ	š	.
8	ê	ś	Ě	⊥	⊥	đ	š	°
9	ë	Ö	ē	⊥	⊥	đ	š	°
A	è	Û		⊥	⊥	đ	š	°
B	ó	Ť	ž	⊥	⊥	■	Ů	ú
C	í	ť	č	⊥	⊥	■	ý	ř
D	Z	ž	š	⊥	⊥	■	Ů	ř
E	Ä	×	«	⊥	⊥	■	Ů	'
F	Ā	č	»	⊥	⊥	■		

Code Page #858
Multi-lingual with Euro

	8	9	A	B	C	D	E	F
0	Ç	É	á	⋯	⊥	đ	ó	-
1	ü	æ	í	⋯	⊥	Đ	β	±
2	é	Æ	ó	⋯	⊥	Đ	ó	=
3	â	δ	ú		⊥	Đ	ó	¼
4	ä	ö	ñ	⊥	-	Đ	ó	½
5	à	ò	Ñ	⊥	+	€	ö	¾
6	â	ú	æ	⊥	ā	í	μ	÷
7	ç	ù	ø	⊥	Å	í	þ	.
8	ê	ÿ	¿	⊕	⊥	ÿ	þ	°
9	ë	Ö	®	⊥	⊥	ÿ	Û	°
A	è	Û	⊥	⊥	⊥	⊥	Û	.
B	ï	ø	½	⊥	⊥	■	Û	1
C	î	£	¾	⊥	⊥	■	ÿ	3
D	i	Ø	¿	⊥	⊥	■	ÿ	2
E	Ä	×	«	⊥	⊥	■	ÿ	'
F	Å	f	»	⊥	⊥	■		

Code Page #860
Portuguese

	8	9	A	B	C	D	E	F
0	Ç	É	á	⋯	⊥	⊥	α	≡
1	ü	À	í	⋯	⊥	⊥	β	±
2	é	È	ó	⋯	⊥	⊥	γ	≥
3	â	δ	ú		⊥	⊥	π	≤
4	ä	ö	ñ	⊥	-	⊥	Σ	∫
5	à	ò	Ñ	⊥	+	⊥	σ	∫
6	À	ú	æ	⊥	ā	⊥	μ	÷
7	ç	ù	ø	⊥	Å	⊥	τ	≈
8	ê	ÿ	¿	⊕	⊥	⊥	φ	°
9	ë	Ö	®	⊥	⊥	⊥	θ	°
A	è	Û	⊥	⊥	⊥	⊥	Ω	.
B	í	ø	½	⊥	⊥	⊥	δ	√
C	î	£	¾	⊥	⊥	⊥	∞	n
D	i	Ø	¿	⊥	⊥	⊥	∅	2
E	Ä	×	«	⊥	⊥	⊥	ε	■
F	Å	f	»	⊥	⊥	⊥	∩	

Other characters are the same as those for Code Page #437.

Code Page #861
Icelandic

	8	9	A	B	C	D	E	F
0	Ç	É	á	█	Ł	Ш	α	≡
1	ü	æ	í	█	ł	т	β	±
2	é	Æ	ó	█	Т	π	Γ	≥
3	à	ð	ú		т	π	Π	≤
4	ä	ö	Á		—	Ł	Σ	∫
5	à	þ	Í		+	F	σ	J
6	â	û	Ö		+	π	μ	+
7	ç	ý	U			τ	τ	≈
8	ê	ý	ı			ϕ	Φ	°
9	ë	ö	ı			ϕ	θ	•
A	è	Û	ı			Ω	Ω	•
B	Ð	ø	½			δ	δ	√
C	ð	£	¼			∞	∞	n
D	Þ	Ø	ı			∅	∅	2
E	Ǻ	ŕ	«			€	€	■
F	Ǻ	f	»			∩	∩	

Code Page #863
Canadian French

	8	9	A	B	C	D	E	F
0	Ç	É	á	█	Ł	Ш	α	≡
1	ü	É	í	█	ł	т	β	±
2	é	É	ó	█	Т	π	Γ	≥
3	à	ð	ú		т	π	Π	≤
4	À	É	“		—	Ł	Σ	∫
5	à	Ï	”		+	F	σ	J
6	ŕ	Û	”		+	π	μ	+
7	ç	ù	—			τ	τ	≈
8	ê	ı	ı			ϕ	Φ	°
9	ë	Ö	ı			ϕ	θ	•
A	è	Û	ı			Ω	Ω	•
B	ï	φ	½			δ	δ	√
C	î	£	¼			∞	∞	n
D	=	Û	¼			∅	∅	2
E	A	Ŕ	«			€	€	■
F	S	f	»			∩	∩	

Code Page #865
Nordic

	8	9	A	B	C	D	E	F
0	Ç	É	á	█	Ł	Ш	α	≡
1	ü	æ	í	█	ł	т	β	±
2	é	Æ	ó	█	Т	π	Γ	≥
3	à	ð	ú		т	π	Π	≤
4	ä	ö	ñ		—	Ł	Σ	∫
5	à	ð	Ñ		+	F	σ	J
6	â	û	æ		+	π	μ	+
7	ç	ù	ø			τ	τ	≈
8	ê	ý	ı			ϕ	Φ	°
9	ë	ö	ı			ϕ	θ	•
A	è	Û	ı			Ω	Ω	•
B	ï	ø	½			δ	δ	√
C	î	£	¼			∞	∞	n
D	ì	Ø	ı			∅	∅	2
E	Ǻ	ŕ	«			€	€	■
F	Ǻ	f	»			∩	∩	

Code Page #866
Russian

	8	9	A	B	C	D	E	F
0	A	P	a	█	Ł	Ш	р	È
1	Б	С	б	█	ł	т	с	ë
2	В	Т	в	█	Т	π	т	€
3	Г	У	г		т	π	у	€
4	Д	Ф	д		—	Ł	ф	Ï
5	Е	Х	е		+	F	х	ı
6	Ж	Ц	ж		+	π	ц	Û
7	З	Ч	з			τ	ч	Û
8	И	Ш	и			ϕ	ш	°
9	Й	Щ	й			ϕ	щ	•
A	К	Ъ	к			Ω	ъ	•
B	Л	Ы	л			δ	ы	√
C	М	Ь	м			∞	ь	№
D	Н	Э	н			∅	э	α
E	О	Ю	о			∅	ю	■
F	П	Я	п			∩	я	

Other characters are the same as those for Code Page #437.

Code Page #869
Greek

	8	9	A	B	C	D	E	F
0		Ι	Ϛ	⋯	Λ	Τ	ξ	-
1		Ϊ	Ϛ	⋯	⊥	Υ	η	±
2		Ο	ό	⋯	Τ	Φ	θ	υ
3			ύ		⊥	Χ	ι	φ
4			Α	⊥	-	Ψ	κ	χ
5		Υ	Β	Κ	+	Ω	λ	§
6	A	Ψ	Γ	Λ	Π	α	μ	ψ
7		⊙	Δ	Μ	Ρ	β	ν	~
8	·	Ω	Ε	Ν	⊥	γ	ξ	°
9	¬	²	Ζ	⋮	⊥	ι	ο	..
A		³	Η		⊥	Γ	π	ω
B	'	ά	½	⊥	⊥	■	ε	ü
C	,	£	Θ	⊥	⊥	■	σ	Û
D	E	έ	Ι	⊥	=	δ	ς	ώ
E	-	ή	«	Ο	⊥	e	τ	■
F	H	ι	»	γ	Σ	■	'	

Code Page #928
Greek

	8	9	A	B	C	D	E	F
0			°	Ϛ	Π	Ϛ	π	
1			'	±	Α	Ρ	α	ε
2			'	²	Β		β	ς
3			£	³	Γ	Σ	γ	σ
4				'	Δ	Τ	δ	τ
5				~	Ε	Υ	ε	υ
6				Α	Ζ	Φ	ξ	φ
7			§	·	Η	Χ	η	χ
8			§	·	Θ	Ψ	θ	ψ
9			⊙	Η	Ι	Ω	ι	ω
A				Ι	Κ	Υ	κ	Ϛ
B			«	»	Λ	Ψ	λ	Ϛ
C			¬		Μ	Ν	μ	ν
D					Ο	Ξ	ο	ξ
E					Υ	Ω	υ	ω
F			-	Ω	Ο	ι	ο	

Code Page #2001
Lithuanian-KBL

	8	9	A	B	C	D	E	F
0	Α	Ρ	α	⋯	Λ	⊥	ρ	Ę
1	Б	С	б	⋯	⊥	⊥	с	ę
2	В	Т	в	⋯	Т	⊥	т	È
3	Г	У	г		⊥	⊥	у	è
4	Д	Ф	д	⊥	-	⊥	ф	İ
5	Е	Х	е	⊥	+	F	х	i
6	Ж	Ц	ж	⋮	⊥	⊥	ц	š
7	З	Ч	э	⋮	⋮	⋮	ч	š
8	И	Ш	и	⋮	⋮	⋮	ш	Ū
9	Й	Щ	й	⋮	⋮	⋮	щ	ų
A	К	Ь	к		⊥	Г	ь	Ū
B	Л	Ы	л	⋮	⋮	■	ы	ū
C	М	Ь	м	⋮	⋮	А	ь	ž
D	Н	Э	н	⋮	=	ą	э	ž
E	О	Ю	о	⋮	⋮	Č	ю	■
F	П	Я	п	γ	±	č	я	

Code Page #3001
Estonian-1

	8	9	A	B	C	D	E	F
0	Ç	É	á	⋯	Λ	š	ó	-
1	ü	æ	í	⋯	⊥	š	β	±
2	é	Æ	ó	⋯	Т	È	ò	=
3	á	ð	ú		⊥	È	ò	≠
4	ä	ö	ñ	⊥	-	È	õ	¶
5	à	ò	ñ	+	⊥	ı	õ	§
6	â	ü	ä	Α	â	ı	μ	+
7	ç	ù	ö	Α	À	ı	z	°
8	ê	ÿ	ı	⊙	⊥	Υ	ž	°
9	ë	ö	⊙	⋮	⊥	⊥	ü	..
A	è	ü	¬		⊥	Г	ü	·
B	ï	ø	½	⋮	⋮	■	ü	ı
C	ı	£	¼	⋮	⋮	⋮	ý	³
D	ì	Ø	ı	⊥	=	ı	ÿ	²
E	ï	×	«	⊥	⋮	ı	-	■
F	À	f	»	γ	α	■	'	

Other characters are the same as those for Code Page #437.

Code Page #1001

Arabic

	0	1	2	3	4	5	6	7	8	9	A	B	C	D	E	F
0	<NULL>		ء	@	ط	ٸ	ي	ح	ا	ظ	ش	ل	ط	ا	ا	ش
1	<DC1>	!	ٸ	نا	ظ	كا	نا	ط	ا	ظ	ط	ا	ا	ا	ا	ا
2	<DC2>	"	ا	نا	ع	ل	ا	ح	ا	ظ	ظ	ا	ا	ا	ا	ا
3	<DC3>	#	و	ظ	ط	لا	ا	ظ	ا	ظ	ا	ا	ا	ا	ا	ا
4	<DC4>	\$	ا	د	ع	لا	ا	ظ	ا	ظ	ا	ا	ا	ا	ا	ا
5	§	%	نا	ن	ظ	لا	ا	ظ	ا	ظ	ا	ا	ا	ا	ا	ا
6		&	ا	ر	ا	ل	ا	ظ	ا	ظ	ا	ا	ا	ا	ا	ا
7	<BEL>	'	ب	ن	ظ	م	ح	ا	ا	ظ	ا	ا	ا	ا	ا	ا
8	<BS> <CAN>	(ب	ي	ظ	م	ظ	ا	ا	ظ	ا	ا	ا	ا	ا	ا
9	<HT>)	ع	ظ	ن	ح	ا	ظ	ا	ظ	ا	ا	ا	ا	ا	ا
A	<LF>	*	:	ظ	كا	نا	ظ	ا	ا	ظ	ا	ا	ا	ا	ا	ا
B	<VT> <ESC>	+	:	ظ	[ا	{	ا	ا	ظ	ا	ا	ا	ا	ا	ا
C	<PF> <FS>	,	<	ظ	\	ظ	--	ا	ا	ظ	ا	ا	ا	ا	ا	ا
D	<CR>	-	=	ظ]	و	}	ا	ا	ظ	ا	ا	ا	ا	ا	ا
E	<SO>	.	>	ظ	^	ي	~	ا	ا	ظ	ا	ا	ا	ا	ا	ا
F	<SI>	/	ظ	ظ	_	نا		ا	ا	ظ	ا	ا	ا	ا	ا	ا

Code Page #3002

Estonian-2

	8	9	A	B	C	D	E	F
0			•	А	Š	à	š	
1		;	±	А	Ń	á	ñ	
2		ϕ	²	А	ò	â	ò	
3		£	³	А	ó	ã	ó	
4		κ	'	А	ô	ä	ô	
5		¥	μ	А	õ	å	õ	
6		!	¶	Æ	ö	æ	ö	
7		§	•	Ç	×	ç	+	
8		:	,	B	ø	è	ø	
9		©	!	B	ù	é	ù	
A		»	»	B	ú	ê	ú	
B		«	»	B	û	ë	û	
C		¬	¼	Y	ü	ì	ü	
D		½	½	Y	ý	í	ý	
E		¾	¾	Y	ÿ	î	ÿ	
F		—	¿	Y	ÿ	ï	ÿ	

Code Page #3011

Lavian-1

	8	9	A	B	C	D	E	F
0	Ç	É	á	⌘	Л	Š	α	È
1	ü	æ	í	⌘	Л	Ŧ	β	ē
2	é	Æ	ó	⌘	Л	č	Γ	Ĝ
3	â	ð	ú		Л	Ĉ	π	ķ
4	ä	ö	ñ		Л	ĉ	Σ	Ķ
5	à	ò	Ń		Л	Ċ	σ	ļ
6	â	û	æ		Л	ċ	μ	ļ
7	ç	ù	ó	¶	Л	ċ	τ	ž
8	ê	ÿ	¿	¶	Л	ċ	Φ	ž
9	ë	ö	¬	¶	Л	ċ	Θ	•
A	è	ù	¬	¶	Л	ċ	Ω	•
B	ï	ϕ	¼	¶	Л	■	δ	√
C	î	£	¼	¶	Л	■	∞	N
D	ì	¥	½	¶	Л	■	∅	š
E	Ë	Ŧ	¾	¶	Л	■	U	■
F	À	f	»	¶	Л	■	∩	

Other characters are the same as those for Code Page #437.

Code Page #3012
Lavian-2

	8	9	A	B	C	D	E	F
0	А	Р	а	⋮	Л	Š	р	Ē
1	Б	С	б	⋮	⊥	Ṛ	с	ē
2	В	Т	в	⋮	┌	č	т	Ĝ
3	Г	У	г		└	č	у	Ķ
4	Д	Ф	д	┌	└	č	ф	Ķ
5	Е	Х	е	┌	└	č	х	↓
6	Ж	Ц	ж	┌	└	č	ц	↓
7	З	Ч	з	┌	└	č	ч	ž
8	И	Ш	и	┌	└	č	ш	ž
9	Й	Щ	й	┌	└	č	щ	•
A	К	Ъ	к	┌	└	č	ъ	•
B	Л	Ы	л	┌	└	č	ы	√
C	М	Ь	м	┌	└	č	ь	N
D	Н	Э	н	┌	└	č	э	š
E	О	Ю	о	┌	└	č	ю	■
F	П	Я	п	┌	└	č	я	■

Code Page #3021
Bulgarian

	8	9	A	B	C	D	E	F
0	А	Р	а	р	Л	⋮	α	≡
1	Б	С	б	с	⊥	⋮	β	±
2	В	Т	в	т	┌	⋮	Γ	≥
3	Г	У	г	у	└		π	≤
4	Д	Ф	д	ф	┌	┌	Σ	∫
5	Е	Х	е	х	└	№	σ	J
6	Ж	Ц	ж	ц	┌	§	μ	÷
7	З	Ч	з	ч	┌	┌	τ	≈
8	И	Ш	и	ш	┌	┌	Φ	°
9	Й	Щ	й	щ	┌	┌	Θ	•
A	К	Ъ	к	ъ	┌	┌	Ω	•
B	Л	Ы	л	ы	┌	┌	δ	√
C	М	Ь	м	ь	┌	┌	∞	n
D	Н	Э	н	э	┌	┌	∅	²
E	О	Ю	о	ю	┌	┌	ε	■
F	П	Я	п	я	┌	┌	∅	∅

Code Page #3031
Hebrew

	8	9	A	B	C	D	E	F
0	א	ב	א	⋮	ל	מ	α	≡
1	כ	ד	כ	⋮	⊥	Ṛ	β	±
2	ג	ה	ג	⋮	┌	π	Γ	≥
3	ד	ו	ד		└	π	π	≤
4	ה	ז	ה	┌	└	כ	Σ	∫
5	ו	ח	ו	┌	└	כ	σ	J
6	ז	ט	ז	┌	└	כ	μ	÷
7	ח	י	ח	┌	└	כ	τ	≈
8	ט	כ	ט	┌	└	כ	Φ	°
9	י	ל	י	┌	└	כ	Θ	•
A	כ	מ	כ	┌	└	כ	Ω	•
B	ד	נ	ד	┌	└	כ	δ	√
C	ה	ס	ה	┌	└	כ	∞	n
D	ו	ע	ו	┌	└	כ	∅	²
E	ז	פ	ז	┌	└	כ	ε	■
F	ח	צ	ח	┌	└	כ	∅	∅

Code Page #3041
Maltese

	8	9	A	B	C	D	E	F
0	Ċ	É	á	⋮	Л	М	α	≡
1	ü	æ	í	⋮	⊥	Ṛ	β	±
2	é	Æ	ó	⋮	┌	π	Γ	≥
3	á	ò	ú		└	π	π	≤
4	ä	ö	ñ	┌	└	ч	Σ	∫
5	à	ò	ñ	┌	└	ч	σ	J
6	â	û	æ	┌	└	ч	μ	÷
7	ç	ù	ø	┌	└	ч	τ	≈
8	ê	ÿ	ç	┌	└	ч	Φ	°
9	ë	ÿ	ç	┌	└	ч	Θ	•
A	è	Ü	ç	┌	└	ч	Ω	•
B	ï	φ	ç	┌	└	ч	δ	√
C	î	£	ç	┌	└	ч	∞	n
D	ì	¥	ç	┌	└	ч	∅	²
E	ì	¥	ç	┌	└	ч	ε	■
F	À	f	»	┌	└	ч	∅	∅

Other characters are the same as those for Code Page #437.

Code Page #3840
IBM-Russian

	8	9	A	B	C	D	E	F
0	А	Р	а	▒	Л	Ш	р	≡
1	Б	С	б	▒	⊥	Ш	с	±
2	В	Т	в	▒	Т	Ш	т	≥
3	Г	У	г		Т	Ш	у	≤
4	Д	Ф	д		—	Е	ф	∫
5	Е	Х	е		+	Р	х	∫
6	Ж	Ц	ж		+	П	ц	+
7	З	Ч	з			Ш	ч	≈
8	И	Ш	и	∟		≠	ш	°
9	Й	Щ	й			∟	щ	•
A	К	Ь	к			∟	ь	•
B	Л	Ы	л			■	ы	√
C	М	Ъ	м				ъ	n ²
D	Н	Э	н				э	²
E	О	Ю	о	∟			ю	■
F	П	Я	п	∟			я	■

Code Page #3841
Gost

	8	9	A	B	C	D	E	F
0	Ғ	Ғ		0	ю	п	Ю	П
1	э	Э	!	1	а	я	А	Я
2	ё	Ё	"	2	б	р	Б	Р
3	і	І	#	3	ц	с	Ц	С
4	ї	Ї	¤	4	д	т	Д	Т
5	ј	Ј	%	5	е	у	Е	У
6	к	К	&	6	ф	ж	Ф	Ж
7	ө	Ө	'	7	г	в	Г	В
8	ұ	Ұ	(8	х	ь	Х	Ь
9	Ү	Ү)	9	и	ы	И	Ы
A	х	Х	*	:	й	э	Й	Э
B	ң	Ң	+	;	к	ш	К	Ш
C	щ	Щ	,	<	л	э	Л	Э
D	ч	Ч	-	=	м	щ	М	Щ
E	е	Е	.	>	н	ч	Н	Ч
F	£	£	/	?	о	ь	О	Ь

Code Page #3843
Polish

	8	9	A	B	C	D	E	F
0	Ç	Ę	Z	▒	Л	Ш	α	≡
1	ü	ę	Z	▒	⊥	Ш	β	±
2	é	ł	ó	▒	Т	Ш	Γ	≥
3	á	ò	Ó		Т	Ш	π	≤
4	ä	ö	ń		—	Е	Σ	∫
5	à	ć	N		+	Р	σ	∫
6	ą	ù	ź		+	П	μ	+
7	ç	ù	ż			Ш	τ	≈
8	ê	ś	ŝ	∟		≠	φ	°
9	ë	ö	ŕ			∟	θ	•
A	è	ù	ŕ			∟	Ω	•
B	ï	ź	½			■	δ	√
C	î	ł	¼				∞	n ²
D	í	ŝ	;				∅	²
E	ä	ś	«	∟			ε	■
F	À	ą	»	∟			∅	■

Code Page #3844
CS2

	8	9	A	B	C	D	E	F
0	Č	É	á	▒	Л	Ш	α	≡
1	ü	ž	í	▒	⊥	Ш	β	±
2	é	ž	ó	▒	Т	Ш	Γ	≥
3	ď	ò	ú		Т	Ш	π	≤
4	ä	ö	ň		—	Е	Σ	∫
5	Ď	ó	Ň		+	Р	σ	∫
6	ť	ù	Ů		+	П	μ	+
7	č	š	ó	∟		Ш	τ	≈
8	ě	ý	š	∟		≠	φ	°
9	Ě	ö	ř			∟	θ	•
A	Ĺ	ù	ř			∟	Ω	•
B	í	š	ř			■	δ	√
C	í	ł	¼				∞	n ²
D	í	ŝ	;				∅	²
E	ä	ś	«	∟			ε	■
F	À	ą	»	∟			∅	■

Other characters are the same as those for Code Page #437.

Code Page #3845
Hungarian

	8	9	A	B	C	D	E	F
0	Ç	É	Á	◻	Ł	⊥	α	≡
1	Ü	Æ	Í	◻	⊥	⊥	β	±
2	É	Æ	Ó	◻	⊥	⊥	Γ	≥
3	À	Ö	Ú		⊥	⊥	π	≤
4	Ä	Ö	Ń		⊥	⊥	Σ	∫
5	À	Ó	Ń		⊥	F	σ	J
6	À	Ú	Æ		⊥	⊥	μ	+
7	Ç	Ú	Ö		⊥	⊥	τ	≈
8	É	Ú	Ö		⊥	⊥	Φ	°
9	Ë	Ö	Ŕ		⊥	⊥	Θ	•
A	È	Û	Ŕ		⊥	⊥	Ω	•
B	Ï	Φ	½		⊥	■	δ	√
C	İ	£	¼		⊥	■	∞	n
D	Í	¥	ı		⊥	■	∅	z
E	Ä	Ŕ	«		⊥	■	ε	■
F	À	f	»		⊥	■	∩	

Code Page #3846
Turkish

	8	9	A	B	C	D	E	F
0	Ç	É	Á	◻	Ł	⊥	α	≡
1	Ü	Æ	Í	◻	⊥	⊥	β	±
2	É	Æ	Ó	◻	⊥	⊥	Γ	≥
3	À	Ö	Ú		⊥	⊥	π	≤
4	Ä	Ö	Ń		⊥	⊥	Σ	∫
5	À	Ó	Ń		⊥	F	σ	J
6	À	Ú	Œ		⊥	⊥	μ	+
7	Ç	Ú	Ö		⊥	⊥	τ	≈
8	É	Ú	Ö		⊥	⊥	Φ	°
9	Ë	Ö	Ŕ		⊥	⊥	Θ	•
A	È	Û	Ŕ		⊥	⊥	Ω	•
B	Ï	Φ	½		⊥	■	δ	√
C	İ	£	¼		⊥	■	∞	n
D	Í	¥	ı		⊥	■	∅	z
E	Ä	Ŕ	«		⊥	■	ε	■
F	À	f	»		⊥	■	∩	

Code Page #3847
Brazil-ABNT

	8	9	A	B	C	D	E	F
0				°	À	Đ	à	đ
1			ı	±	Á	Ñ	á	ñ
2			φ	²	Â	Ò	â	ò
3			£	³	Ã	Ó	ã	ó
4			¤	´	Ä	Ô	ä	ô
5			¥	µ	Å	Ö	å	ö
6				¶	Æ	Ø	æ	ø
7			§	•	Ç	Ç	ç	ç
8			¨	,	È	Ø	è	ø
9			©	ı	É	Ù	é	ù
A			ª	º	Ê	Ú	ê	ú
B			«	»	Ë	Û	ë	û
C			¬	¼	Ì	Ü	ì	ü
D			¬	½	Í	Ý	í	ý
E			®	¾	Î	Þ	î	þ
F			—	¿	Ï	ß	ï	ÿ

Code Page #3848
Brazil-ABICOMP

	8	9	A	B	C	D	E	F
0				Ò	ı	ò		
1				Ó	à	ó		
2			À	Ô	á	ô		
3			À	Õ	â	õ		
4			À	Ö	ã	ö		
5			À	Æ	ä	æ		
6			Ç	Ù	ç	ù		
7			È	Ú	è	ú		
8			È	Û	é	û		
9			È	Ü	ê	ü		
A			È	Ý	ë	ý		
B			Ì		ì	ÿ		
C			Í	£	í	ª		
D			Í		ï	ª		
E			Ï	§	ï	¿		
F			Ñ	°	ñ	±		

Other characters are the same as those for Code Page #437.

International Character Set

Conuntry	23	24	40	58	5A	5B	5C	5D	5E	60	7B	7C	7D	7E
U.S.A.	#	\$	@	X	Z	[\]	^	`	{		}	~
FRANCE	#	\$	à	X	Z	°	ç	§	^	`	é	ù	è	¨
GERMANY	#	\$	§	X	Z	Ä	ö	ü	^	`	ä	ö	ü	ß
ENGLAND	£	\$	@	X	Z	[\]	^	`	{		}	~
DENMARK 1	#	\$	@	X	Z	Æ	Ø	Å	^	`	æ	ø	å	~
SWEDEN	#	¤	É	X	Z	Ä	Ö	Å	Ü	é	ä	ö	å	ü
ITALY	#	\$	@	X	Z	°	\	é	^	ù	à	ò	è	ì
SPAIN 1	₧	\$	@	X	Z	;	Ñ	¿	^	´	¨	ñ	}	~
JAPAN	#	\$	@	X	Z	[¥]	^	`	{		}	~
NORWAY	#	¤	É	X	Z	Æ	Ø	Å	Ü	é	æ	ø	å	ü
DENMARK 2	#	\$	É	X	Z	Æ	Ø	Å	Ü	é	æ	ø	å	ü
SPAIN 2	#	\$	á	X	Z	;	Ñ	¿	é	´	í	ñ	ó	ú
LATIN AMERICA	#	\$	á	X	Z	;	Ñ	¿	é	ü	í	ñ	ó	ú
KOREA	#	\$	@	X	Z	[₩]	^	`	{		}	~
IRELAND	#	\$	@	Ú	/	[\]	^	`	Á	É	Ó	~
LEGAL	#	\$	§	X	Z	°	'	"	¶	`	©	®	†	™

Appendix C. Control Panel Operation Guide

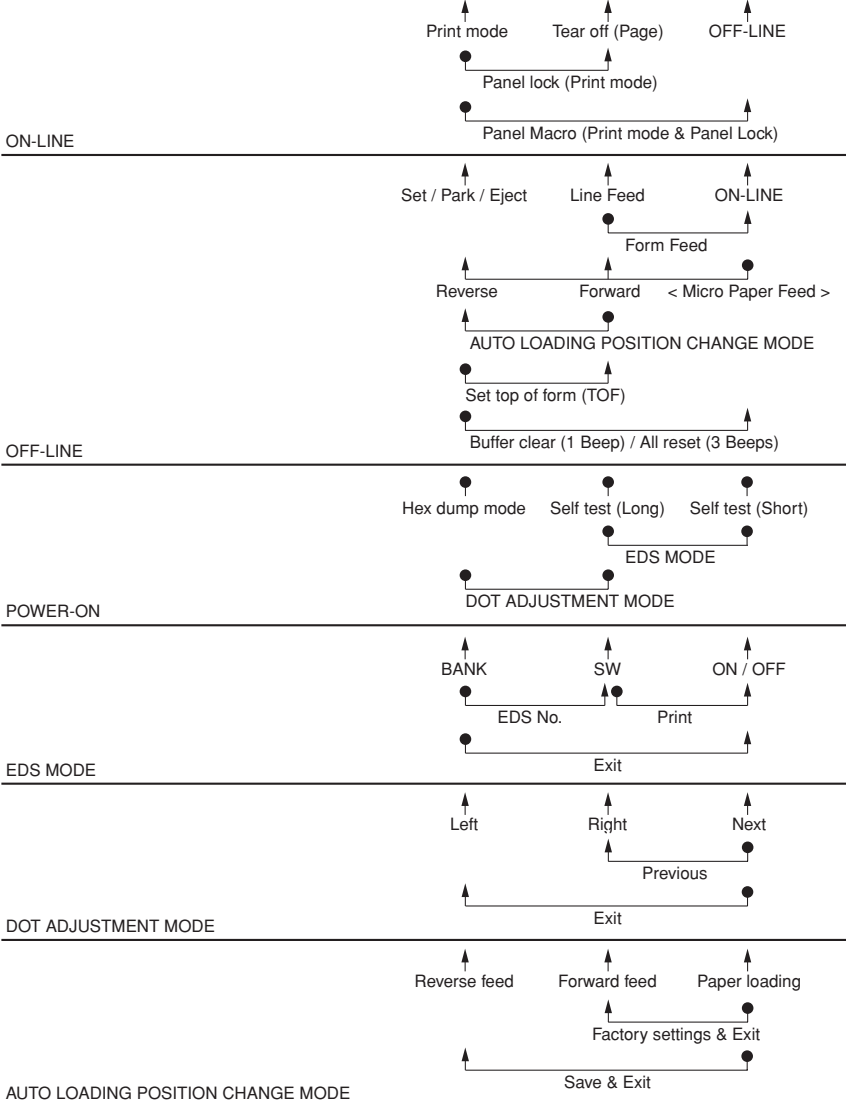
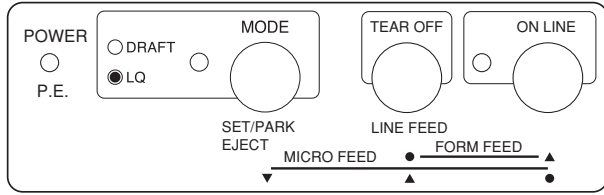
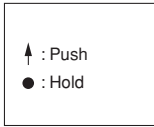



**STAR MICRONICS ASIA LTD.
HEAD OFFICE**

Rm. 1901-6, 19/F., Enterprise Square Two,
3 Sheung Yuet Road, Kowloon Bay, Hong Kong

TEL: +852-2796-2727

FAX: +852-2799-9344

E-mail: smh@starhkg.com.hk

Web site: <http://www.starhkg.com.hk/>

EUROPEAN OFFICE

C.P. 58, CH-6914 Carona,
Ticino, Switzerland

TEL: +41-91-630.62.08

FAX: +41-91-630.62.09

E-mail: Gaudenz.Juon@dial.eunet.ch
