

Installation/Care/Use Manual

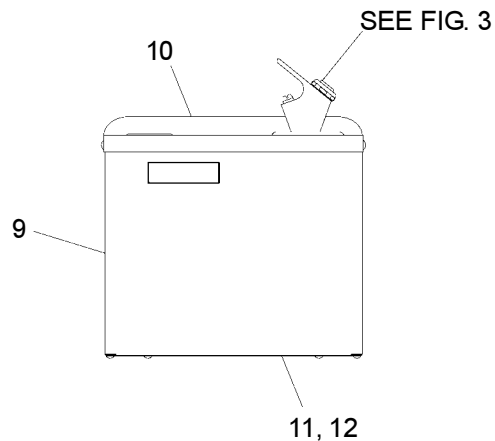

Installer

To assure you install this model easily and correctly, PLEASE READ THESE SIMPLE INSTRUCTIONS BEFORE STARTING THE INSTALLATION. CHECK YOUR INSTALLATION FOR COMPLIANCE WITH PLUMBING, ELECTRICAL AND OTHER APPLICABLE CODES. After installation, leave these instructions inside the fountain for future reference.

IMPORTANT

ALL SERVICE TO BE PERFORMED BY AN AUTHORIZED SERVICE PERSON

IMPORTANT! INSTALLER PLEASE NOTE.

THE GROUNDING OF ELECTRICAL EQUIPMENT SUCH AS TELEPHONE, COMPUTERS, ETC. TO WATER LINES IS A COMMON PROCEDURE. THIS GROUNDING MAY BE IN THE BUILDING OR MAY OCCUR AWAY FROM THE BUILDING. THIS GROUNDING CAN CAUSE ELECTRICAL FEEDBACK INTO A FOUNTAIN, CREATING AN ELECTROLYSIS WHICH CAUSES A METALLIC TASTE OR AN INCREASE IN THE METAL CONTENT OF THE WATER. THIS CONDITION IS AVOIDABLE BY USING THE PROPER MATERIALS AS INDICATED. ANY DRAIN FITTINGS PROVIDED BY THE INSTALLER SHOULD BE MADE OF PLASTIC TO ELECTRICALLY ISOLATE THE FOUNTAIN FROM THE BUILDING PLUMBING SYSTEM.

INSTALLATION INSTRUCTIONS

- 1. Wall** should already be framed for the fountain using the positioning dimensions shown in Figure 1. Shown dimensions pertain to installation location (framing must support up to 150 lbs. weight).
- 2. Install** rough-in plumbing as shown in Figure 1. Connecting lines to be unplated copper. Run supply water inlet line and connect to a service stop (not provided). Turn on supply water and flush thoroughly. Close water supply.
- 3. Secure** the fountain to the wall using bolts and washers (not provided). Tighten securely.
- 4. Make** water supply connections from service stop to the fountain. Turn on water supply and check for leaks. Newly installed water supply line should be insulated after leak check is completed.
- 5. These** products are designed to operate on 20-105 PSIG supply line pressure. If inlet pressure is above 105 PSIG, a pressure regulator must be installed in the supply line. Any damage caused by reason of connecting these products to supply line pressures lower than 20 PSIG or higher than 105 PSIG is not covered by warranty.
- 6. Check** stream height from bubbler. Stream height is factory set at 35 PSI. If supply pressure varies greatly from this, remove items 7 and 8 (See Figure 3) and adjust the screw on the regulator (Item 5). Clockwise adjustment will raise stream height and counter-clockwise will lower stream height. For best adjustment stream should be approximately 1" (25mm) above the bubbler guard. (See Figure 2).

TROUBLE SHOOTING AND MAINTENANCE

- 1. Orifice Assy:** Mineral deposits on orifice can cause water flow to spurt or not regulate. Mineral deposits may be removed from orifice with a small round file not over 1/8" diameter or a small diameter wire. **CAUTION: Do not file or cut orifice materials.**

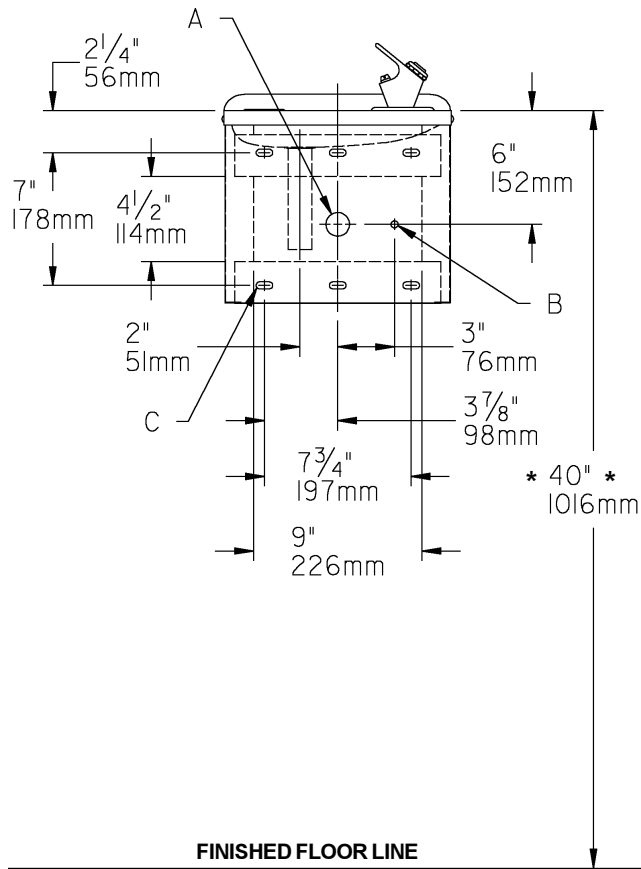

FIG. 1

PARTS LIST		
ITEM NO.	PART NO.	DESCRIPTION
1	45703C	Bubbler Assy
2	60291C	Screen
3	45675C	Bubbler Body
4	40322C	Orifice Assy
5	61313C	Regulator
6	10031C	Retaining Nut
7	40048C	Button
8	40089C	Cover Nut
9	26758C	Cabinet
10	21812C	Basin and Tailpipe Assy
11	26759C	Bottom Cover
12	70059C	Speed Nut
13	75580C	Lock Nut

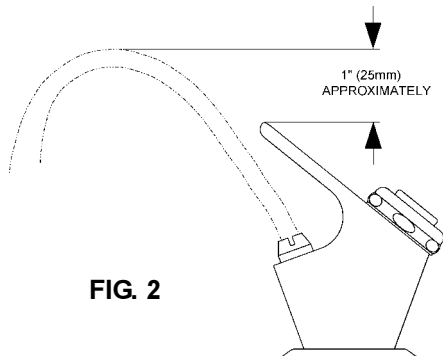

FIG. 2

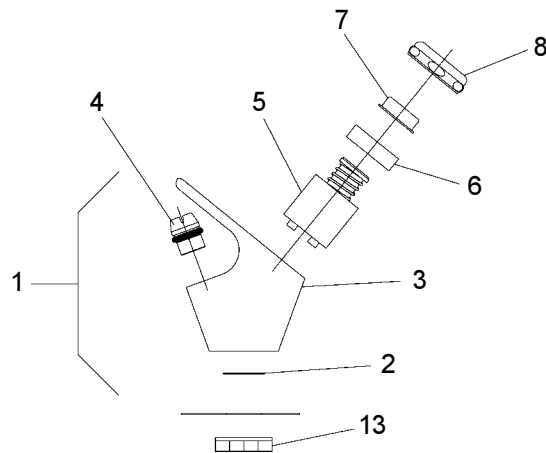

FIG. 3