

Canon

KH21ex5.7 IRSE

Canon's Philosophy :

Canon has always developed new technology with four basic philosophies, "High Quality of Picture", "Ease of Operation", "High Specification" and "Minimize Environmental Impact". Canon's HDTV lenses are, so to speak, a compilation of our basic philosophies. Now, Canon adds a new concept to the HDTV lenses by launching the new HDgc Series.



HDGC

KH21ex5.7 IRSE

HDGC

Canon's Philosophy:

Canon has always developed new technology with four basic philosophies, "High Quality of Picture", "Ease of Operation", "High Specification" and "Minimize Environmental Impact". Canon's HDTV lenses are, so to speak, a compilation of our basic philosophies. Now, Canon adds a new concept to the HDTV lenses by launching the new HDgc Series.

Canon's New HDgc Series

HDGC

Concept of HDgc Series

Corresponding to the popularity of digital High Definition broadcasting and diversity of HDTV equipment, Canon has added a new series to its HDTV lens line up, the HDgc series. The new HDgc series supports the emergence of an important new generation of cost-effective HD acquisition systems. Adopting the advantages created by Canon's unique technology, the new HDgc lenses exhibit high MTF, high resolution and high contrast from the center of the image to its extreme edges, meanwhile maintaining its compact size and weight.

Another important policy of Canon's is not to pollute the earth and the HDgc series succeeded in excluding harmful substances such as cadmium, PBBS, PBDPE or mercury from the mechanical parts, and at the same time incorporating lead free glass and reducing the amount of hazardous substances used in electrical parts.

Meet Canon's new HDgc series lenses, a compilation of Canon's advanced technologies.

Optical Performance of HDgc Series

Aberration Correction for HDgc Lenses

In the HDTV system the pixel size is about half. Therefore, the spread of a point image caused by a spherical aberration, coma etc. should be diminished to about half. The MTF varies as the focus changes and even if the image is slightly out of focus, the MTF is greatly influenced as shown in Graph 1. HDgc greatly contributes to correcting and minimizing these aberrations at the same time maintaining high MTF throughout the edge of the picture.

Special Optical Elements

With the goal of minimizing chromatic aberration, the HDgc series lenses utilizes special elements including an artificially re-crystallized element, "Fluorite", with extraordinary dispersion characteristics and the newly developed "Hi-UD" (high index ultra low dispersion) glass. Canon has succeeded in the practical use of special elements along with advanced design techniques like "separate achromatism".

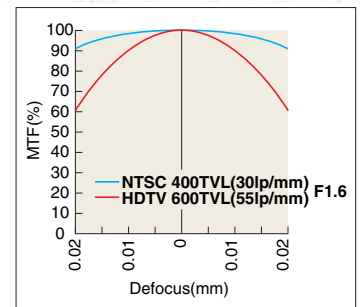

< Graph 1 >

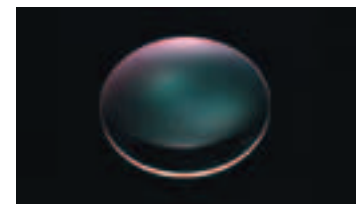

Hi-UD Glass

Enhanced Digital Drive

The KH21ex5.7 and the KH10ex3.6 carries Canon's original Enhanced Digital Drive, a drive unit equipped with an information display and a digital function selector so that the user can customize the enhanced digital functions much more easily and precisely. The new design enables the user to fully bring out the digital functions.

Main Features

(Display Image)

Shuttle Shot : By memorizing any two focal lengths, the digital drive can automatically "shuttle" between the two points, moving in either direction.



Framing Preset : An angle of view can be preset in either of two memories and the lens will zoom to that position by pushing a simple button. During a performance, framing preset will reproduce the zoom position decided upon at the rehearsal. It is easy to repeat the same zoom as often as you like at the highest speed or in a preset zoom speed.



Speed Preset : A specific zoom speed can be preset in memory and it is possible to repeat the zoom speed as often as you like by pushing a simple button.



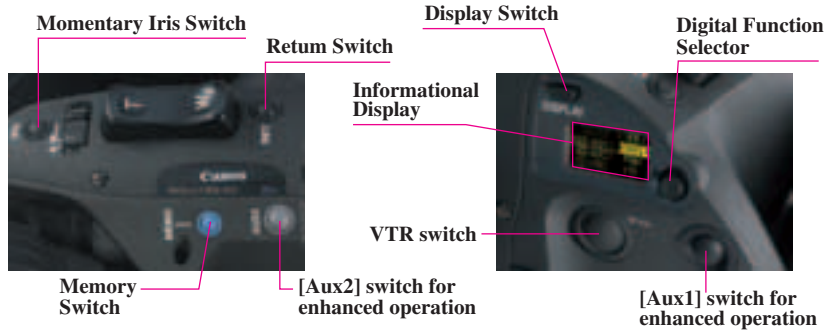

Enhanced Digital Drive Unit

Ecological Design



HDTV Optical Performance

- Reduced Chromatic Aberrations
- High and Flat MTF
- Countermeasures Against Ghosting and Flares

Rotary Encoder

The KH21ex5.7 is equipped with an enhanced digital drive unit. Conventional potentiometers are analog positional sensors capable of only 8-10 bit equivalent resolution. Thus virtual ENG studio systems called for an optional Encoder Unit to be put on the zoom and focus ring of the lens. With the introduction of 16 bit resolution Rotary Encoder Devices built into the new enhanced digital drive unit, the lens can simply be integrated into a virtual digital studio system without any additions. The encoders also enable superior precise control. The zoom servo provides a dynamic range of 0.5 sec. to over a 5 min. super slow zoom. Repeatability in focus and iris control are also much more precise. Canon's unique technology has made the encoder device surprisingly small to be installed in the existing drive unit without changes in size or weight.

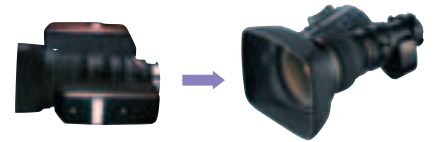

Lens with Optional Encoder Unit

Lens with Encoder Devices included in the Drive Unit

Ecological Design

The HDgc series has succeeded in reducing the use of harmful and hazardous substances that could pollute the environment.

SPECIFICATIONS

KH21ex5.7 IRSE

	16:9	
Built-in extender	1.0X	2.0X
Zoom Ratio	21X	
Range of Focal Length	5.7 – 120mm	11.4 – 240mm
Maximum Relative Aperture	1:1.4 at 5.7 – 86mm 1:1.95 at 120mm	1:2.8 at 11.4 – 172mm 1:3.9 at 240mm
Angular Field of View	62.9° x 38.0° 3.3° x 1.9°	34.0° x 19.5° 1.7° x 0.9°
Minimum object Distance (M.O.D.)	0.8m (10mm with Macro)	
Object Dimensions at M.O.D.	92.2 x 51.9cm at 5.7mm 4.3 x 2.4cm at 120mm	46.1 x 26.0cm at 11.4mm 2.2 x 1.2cm at 240mm
Approx. Size	W x H x L = 169.4 x 111.9 x 217.5 mm	
Approx. Mass	1.79kg	

DIMENSIONS

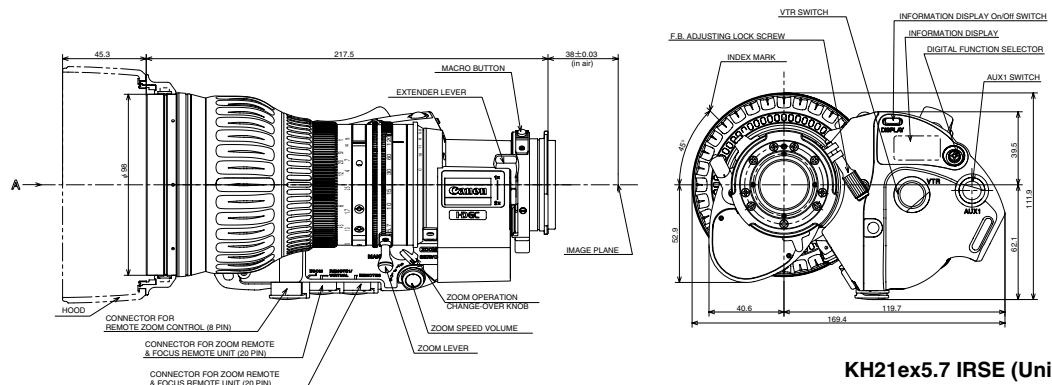

KH21ex5.7 IRSE (Unit:mm)

LENS CONTROLLERS

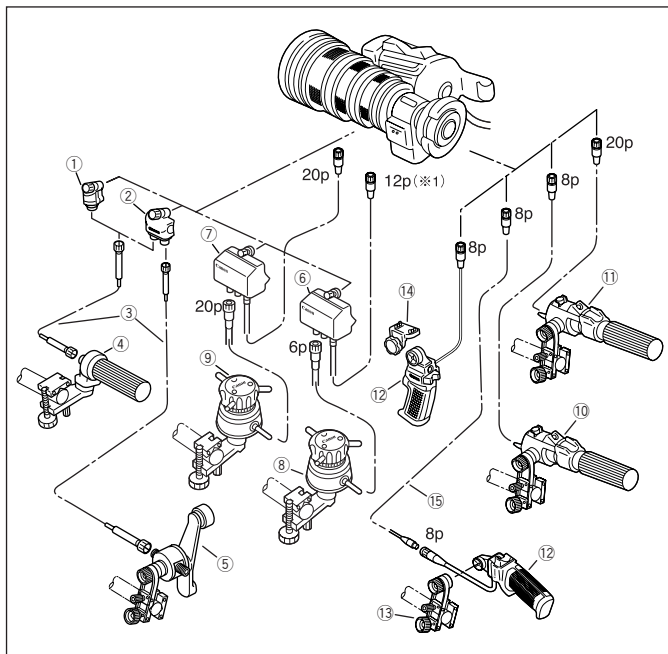

#	Unit	Description	CODE
①	FFM-100	Flex Focus Module	1824A015
②	FFM-200	Flex Dual Module	1824A013
③	FC-40	Flex Cable	1824A010
④	FFC-200	Flex Focus Controller	1824A014
⑤	FZC-100	Flex Zoom Controller	1824A021
⑥	FPM-420	Focus Positional Servo Module	1824A026
⑦	FPM-420D	Focus Positional Servo Module	1824A129
⑧	FPD-400	Focus Positional Demand	1824A018
⑨	FPD-400D	Focus Positional Demand	1824A124
⑩	ZSD-300A/M	Zoom Demand (A or M types, depends on applicable camera)	A 1824A066 M 1824A067
⑪	ZSD-300D	Zoom Demand	1824A123
⑫	ZSG-200A/M	Zoom Servo Grip (A or M types, depends on applicable camera)	A 1824A068 M 1824A069
⑬	CR-10	Clamper	1824A007
⑭	ZGA-600	Grip Adapter	
⑮	EC-80	Zoom Extension Cable (8P)	1824A009
⑯	CC-2006	Conv. Cable (20pM-6pF)	1824A125
⑰	CC-2012	Conv. Cable (20pM-12pF)	1824A126

(※1) CC-2012 conversion cable is necessary to connect between IRSE Digital Drive Lens and FPM-420.

OPTICAL ACCESSORIES

1. CONVERTERS/ATTACHMENTS

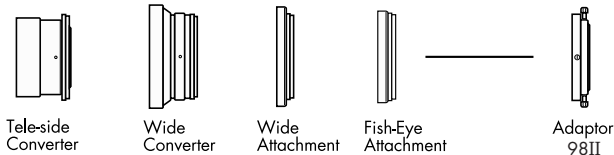

2. FILTERS

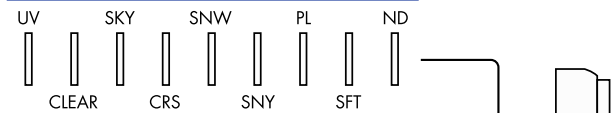

3. CLOSE UP LENSES

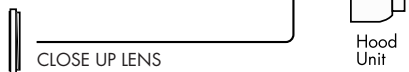

KH21ex5.7 IRSE Lens

TYPE	MODEL
Tele-side Converter 1.5x	T15II
	T15HD*3
Wide Converter	W80-IIIIB
	W80HD*3
Wide Attachment	WA-75II
	WA75HD*3
Fish-Eye Attachment	FEA-IIIIB
Adaptor	98II
Ultra Violet	UV/105mm*2
ND8(12.5% Transmittance)	ND8/105mm
Softon	SFT/105mm
Cross Screen	CRS/105mm
Snow Cross	SNW/105mm
Sunny Cross	SNY/105mm
Polarized Light	PL/105mm
Close-Up Lens	105CL-UP900H
	105CL-UP800HD*3

*1 The filters are to be attached to the threaded hood unit.
*2 UV/94mm is also available for direct attachment to front of lens.
*3 The HD quality accessories offer higher optical performance.

North & South America

Canon U.S.A., Inc.
Broadcast and Communications Div. (Headquarters)
65 Challenger Road, Ridgefield Park, NJ 07660
Tel:(201)807-3300 / (800)321-4388
Fax:(201)807-3333
Email:bctv@usa.canon.com
http://www.canonbroadcast.com/

Chicago

100 Park Blvd. Itasca, IL 60143
Tel:(630)250-6236 Fax:(630)250-0399

Atlanta

5625 Oakbrook Pkwy. Norcross, GA 30093
Tel:(770)849-7890 Fax:(770)849-7888

Los Angeles

15955 Alton Parkway Irvine, CA 92618
Tel:(949)753-4330 Fax:(949)753-4337

Dallas

3200 Regent Blvd. Irving, TX 75063
Tel:(972)409-8871 Fax:(972)409-8869

Latin America

Tel:(954)349-6975 Fax:(201)807-3333

Canada

Canon Canada, Inc.
Broadcast and Communications Div.
6390 Dixie Road
Mississauga, Ontario, L5T 1P7, Canada
Tel:(905)795-2012 Fax:(905)795-2140

Europe/Africa/Middle East

Canon Europa N.V.
Broadcast and Communications Div.
Bovenkerkerweg 59-61
1185 XB Amstelveen
Tel:+31(0)20-5458905 Fax:+31(0)20-5458203
Email:tvprod@canon-europe.com
http://www.canon-europe.com/tv-products

Australia

Canon Australia Pty. Ltd.
Optical Products Division
1 Thomas Holt Drive, North Ryde, NSW 2113, Australia
Tel:+61(0)2-9805-2000 Fax:+61(0)2-9805-2444

China

Canon (China) Co., Ltd.
Optical Products Division
15F Jinbao Building No.89 Jinbao Street
Dongcheng District, Beijing 100005, China
Tel:86-10-85139999 Fax:86-10-85139902
http://www.canon.com.cn

Asia/Japan

Canon Inc.(Broadcast Equipment Group)
23-10, Kiyohara-Kogyo-Danchi, Utsunomiya-shi,
Tochigi-ken, 321-3298, Japan
Tel:+81(0)28-667-8669 Fax:+81(0)28-667-8672
http://www.canon.com/bctv/

http://www.canon.com/bctv

Specifications subject to change without notice