



# AudioSource®

## AS8SW

8" In-Wall Subwoofer

**Congratulations on your purchase of the AudioSource AS8SW In-Wall Subwoofer. This product is designed to reproduce the Low Frequency audio portion of your home entertainment system with accuracy and detail that will satisfy the most discriminating listener.**

**Please read this Installation Manual to ensure the proper installation and performance of your AS8SW speaker.**

### Preparing for your Installation

Gather the necessary tools for your installation.

You will need the following tools:

- 1) A Keyhole or Drywall Saw
- 2) A Phillips Screwdriver
- 3) Masking Tape
- 4) A Pencil
- 5) A Bubble or Laser Level
- 6) A Tape Measure
- 7) A Stud Finder (recommended)
- 8) Your AS8SW Speaker

### Placement

Plan your speaker placement carefully. Make certain that electrical, plumbing and any other services will not interfere within the walls where you plan to place your speakers. The AS8SW speakers can be mounted in the walls or in the ceiling, but are typically used in walls. The speakers should be located so that they provide even coverage at your listening position. The distance between the speakers should not be greater than the distance from the speakers to the listening position.

(see fig. 1)

### Existing Construction

In most modern buildings the wall studs are positioned on 16" centers, providing a space between the studs of approximately 14 3/8". The AS8SW requires a mounting hole 8 3/4" wide and 8 3/4" high. Additionally, you should allow an extra inch in all directions behind the wall surface to allow room for the doglegs that retain the frame to the wall surface to swing into position.

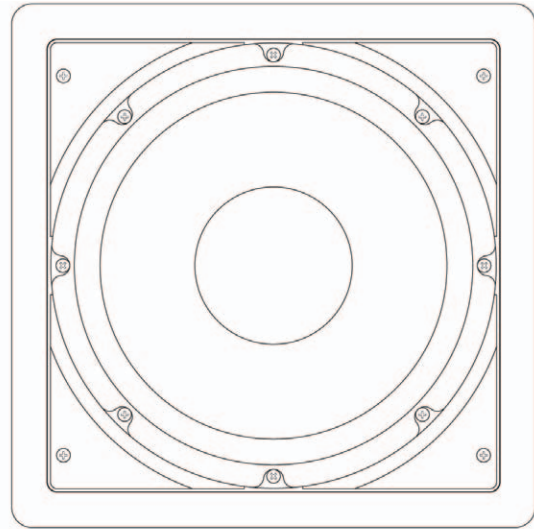

AS8SW

Use a stud finder to locate the vertical studs behind the wall surface. You should now check for obstructions like cross bracing above and below the desired speaker location.

After selection of the mounting location, mark the hole to be cut out. A template is provided in the speaker box. Locate and level the template, then mark with pencil on the wall surface. If you are unsure whether there are obstructions behind the wall surface where the speakers are to be mounted, cut a small hole in the center of your marked mounting location. Holding your drywall saw at a 45 degree angle (see Fig. 2) cut a square hole that you can use to find any obstructions, should they exist.

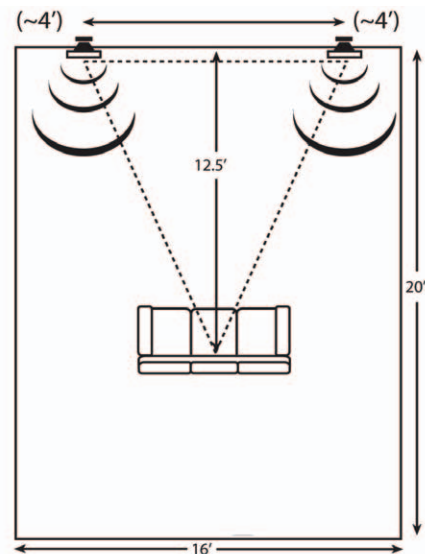
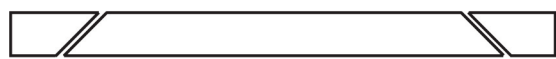

Figure 1

Once it has been determined that there are no obstructions, cut the hole to mount the speaker using the drywall saw at a 90 degree angle to the wall surface. Cover the raw edges of the wallboard with masking tape (see Fig. 3). This will prevent the back pressure of the speaker from blowing loose gypsum dust out and on to the painted wall surface after installation. Do not allow the tape to extend more than 1/2" beyond the edge of the hole into the room. The frame of the AS8SW will cover and hide the tape.



ROOM  
Figure 2

Next, run your speaker wire to your speaker locations. A UL rated, CL3 speaker wire, is recommended when running wire inside your walls (such as Phoenix Gold Innovative Home SS162W\*). In many areas it may be required by code. When running your speaker wire you should avoid having the speaker wire run parallel to the 110V power lines to avoid picking up hum and interference from the power service. If the speaker wire needs to cross a 110V power line do it at a right angle, this is acceptable and should not create a problem.

If you are uncomfortable with running the speaker wire yourself in existing construction, it is recommended that you retain a qualified custom home installation specialist or electrician.

\*Available in 3 convenient lengths: 50' mini-spool (M1650W), 100' mini-spool (M16100W), and 250' bulk spool (SS162W/250).

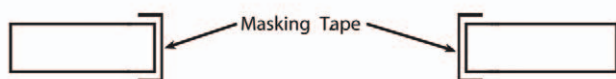

ROOM  
Figure 3

### Installing the Subwoofer

**Installation Tip!** To further enhance the performance of your AS8SW speakers, the wall stud cavity where you plan to place your speakers can be stuffed with a generous quantity of fiberglass insulation. If uninsulated, stuff the area above and under the speaker opening with 6" thick insulation to a depth of approximately 2 feet beginning 1 foot above and 1 foot below the speaker opening. If the insulation is foil or paper backed, face the backing away from the AS8SW speaker. The addition of this insulation will help prevent the unwanted transfer of sound into the large and resonant cavity of the uninsulated wall.

It is now time to connect the speaker wire to the AS8SW. Your speaker wire is usually coded to maintain proper system phasing. This can be by color coding, or one conductor may have a printed marking or at least a rib along one edge that will not be found on the other. Identify which type of polarity coding that your wire is using. You must carefully observe that the positive terminal of the speaker output on your amplifier is connected to the positive terminal of the AS8SW speaker. Likewise, the negative terminal of the amplifier's speaker output should be connected to the negative terminal of the AS8SW speaker (Fig. 4).

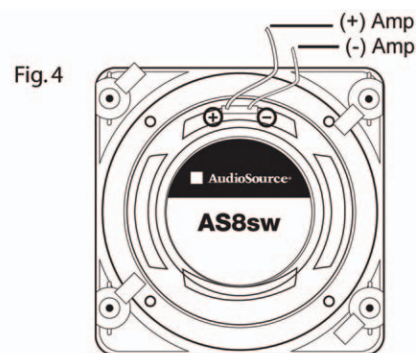

Fig.4

Next, make sure that the doglegs are positioned inside the frame of the speaker (Fig. 5).

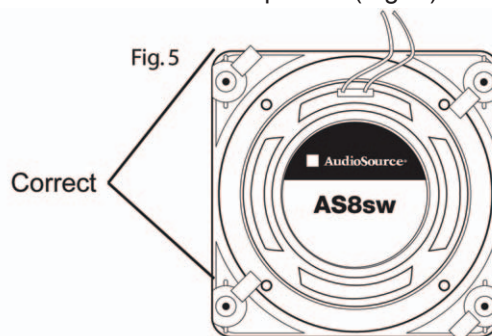

Fig.5

With the grill removed, place the speaker in the wall opening. Make sure that the speaker wire is not hanging against the speaker where it can vibrate and rattle as the speaker reproduces your music.

Next, one at a time, turn each of the four screws (Fig. 6) that operate the doglegs counter clockwise a few turns until you feel the dogleg is loose from its resting position. Now turn the screw clockwise until you feel the dogleg contact the wall surface.

Tighten all four of the mounting screws in the same manner until the speaker is properly aligned and held securely to the wall surface.

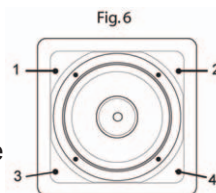

Fig.6

**Caution: Do not over tighten!**

## Painting the Speaker

A paint shield is included in the AS8SW speaker package. Place the paint shield inside the frame to protect the speaker. You can now safely paint the speaker frame to match your wall surface if you desire.

When painting the grill caution should be taken to ensure that paint does not clog or block the perforated openings in the grill. This would prevent full operation from the speaker.

## Removing the AS8SW Subwoofer

Should it ever become necessary to remove the AS8SW speaker from the wall, simply remove the grill and turn the four mounting screws counter-clockwise until the doglegs lock out of position in their resting seat.

## Recommended Speaker Wire Gauges

The resistance of the speaker wire in your installation can cause your subwoofer to perform at less than an optimum quality level. Excess resistance, caused by using an under-sized speaker wire, can result in loss of detail and definition in the low frequency region of your audio program, as well as a loss of dynamic range.

To prevent this effect in your installation, we have recommended speaker wire gauges that should not exceed 0.5 Ohms resistance over the recommended length of wire run.

For the AS8SW subwoofer, we suggest the following minimum speaker wire gauge be used:

- 50' or less – 16 Gauge 2-Cond. CL3
- 50' – 150' – 12 Gauge 2-Cond. CL3
- 150' – 200' – 10 Gauge 2-Cond. CL3

**AS8SW Side profile**

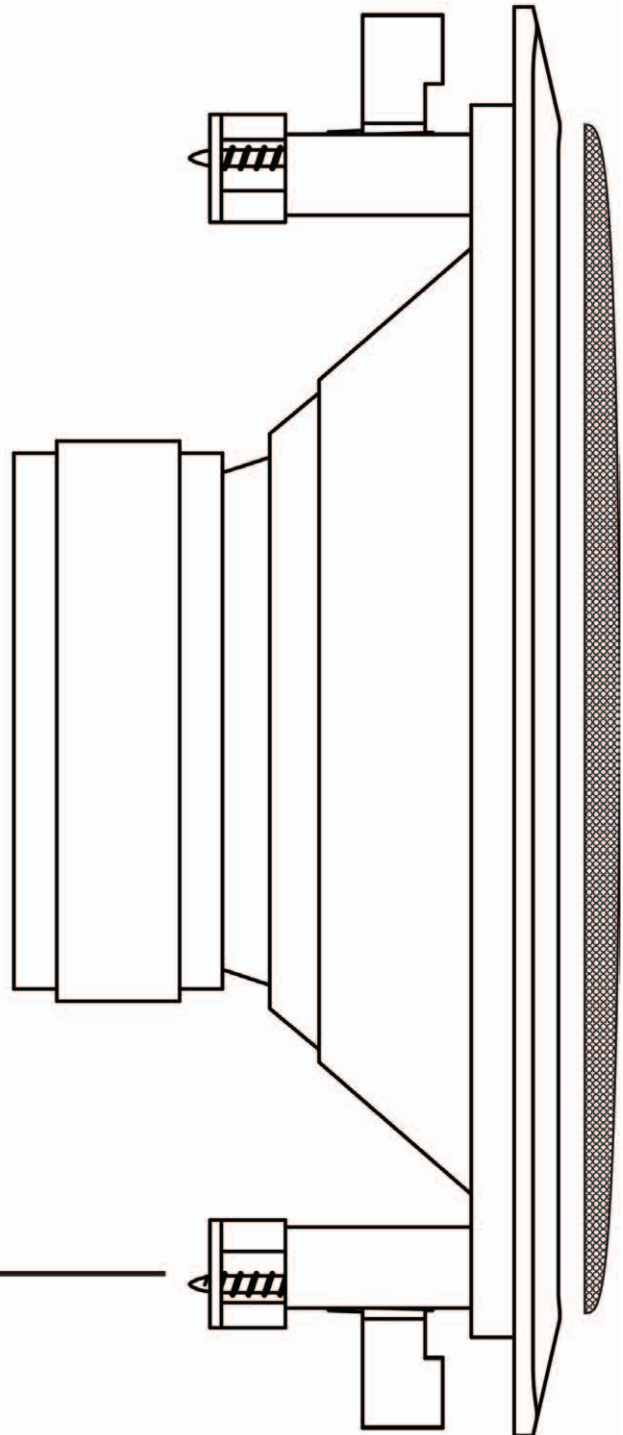

# AS8SW Specifications

<b>Woofers</b>	<b>8" Carbon Poly Cone with Butyl Surround</b>
<b>Frequency Response</b>	<b>40 Hz to 200 Hz</b>
<b>Impedance</b>	<b>8 Ohm</b>
<b>Sensitivity</b>	<b>86dB@2.83V</b>
<b>Recommended Amp Power</b>	<b>25 to 125 Watts Continuous</b>
<b>Cut Out Dimension</b>	<b>8 3/4" x 8 3/4" (22.2cm X 22.2cm)</b>

## Two Year Limited Warranty

AudioSource, a division of Rodin, warrants this product against defects in materials and workmanship for a limited period of time. For a period of two (2) years from date of original purchase, we will repair or replace the product, at our option, without charge for parts. Customer must pay for all labor charges associated with the removal and re-installation of speakers for the limited period and all parts and labor charges after the limited warranty period expires. The limited warranty period for factory refurbished products expires after ninety (90) days from date of original purchase. This limited warranty applies only to purchases from authorized AudioSource Retailers or Distributors. This limited warranty is extended only to the original purchaser and is valid only to consumers in the United States.

Consumers are required to provide a copy of the original sales invoice from an authorized AudioSource Retailer, or Distributor, when making a claim against this limited warranty. This limited warranty only covers failures due to defects in materials or workmanship that occur during normal use. It does not cover failures resulting from accident, fire, flood, misuse, neglect, mis-handling, mis-application, alteration, faulty installation, modification, service by anyone other than AudioSource, or damage that is attributable to Acts of God. It does not cover costs of transportation to AudioSource or damage in transit. The customer should return their defective product, freight prepaid and insured, to AudioSource only after receiving a Return Authorization.

Repair or replacement under terms of this warranty does not extend the term of this warranty. Should a product prove to be defective in workmanship or material, the consumer's sole remedies will be repair or replacement as provided under the terms of this warranty. If the defective product is discontinued AudioSource may replace the product with an equivalent or superior product at its option. Any cost of re-installation or repair of wall or ceiling surface is the sole responsibility of the customer and that cost shall not be the responsibility of AudioSource. Under no circumstances shall AudioSource be liable for loss or damage, direct, consequential or incidental, arising out of the use of or inability to use the product. There are no express warranties other than described above.



Rodin 9200 North Decatur Street Portland, Oregon 97203  
Tel: 503.286.9300 Fax: 503.978.3381 Tech Support: 800.950.1449  
Web: [www.AudioSource.net](http://www.AudioSource.net) Email: [support@phoenixgold.com](mailto:support@phoenixgold.com)