

DUERR

VERTICAL LOG SPLITTERS

MODEL NUMBERS

PRO/20

(248-622-003)

424/LCD/20

(248-623-003) PRO 22

IMPORTANT:

- Read this Manual Before Attempting to Assemble and Use

- Read Safety Rules and Instructions Carefully

- Protect Your Warranty — Read Separate Log Splitter Information Sheet Carefully

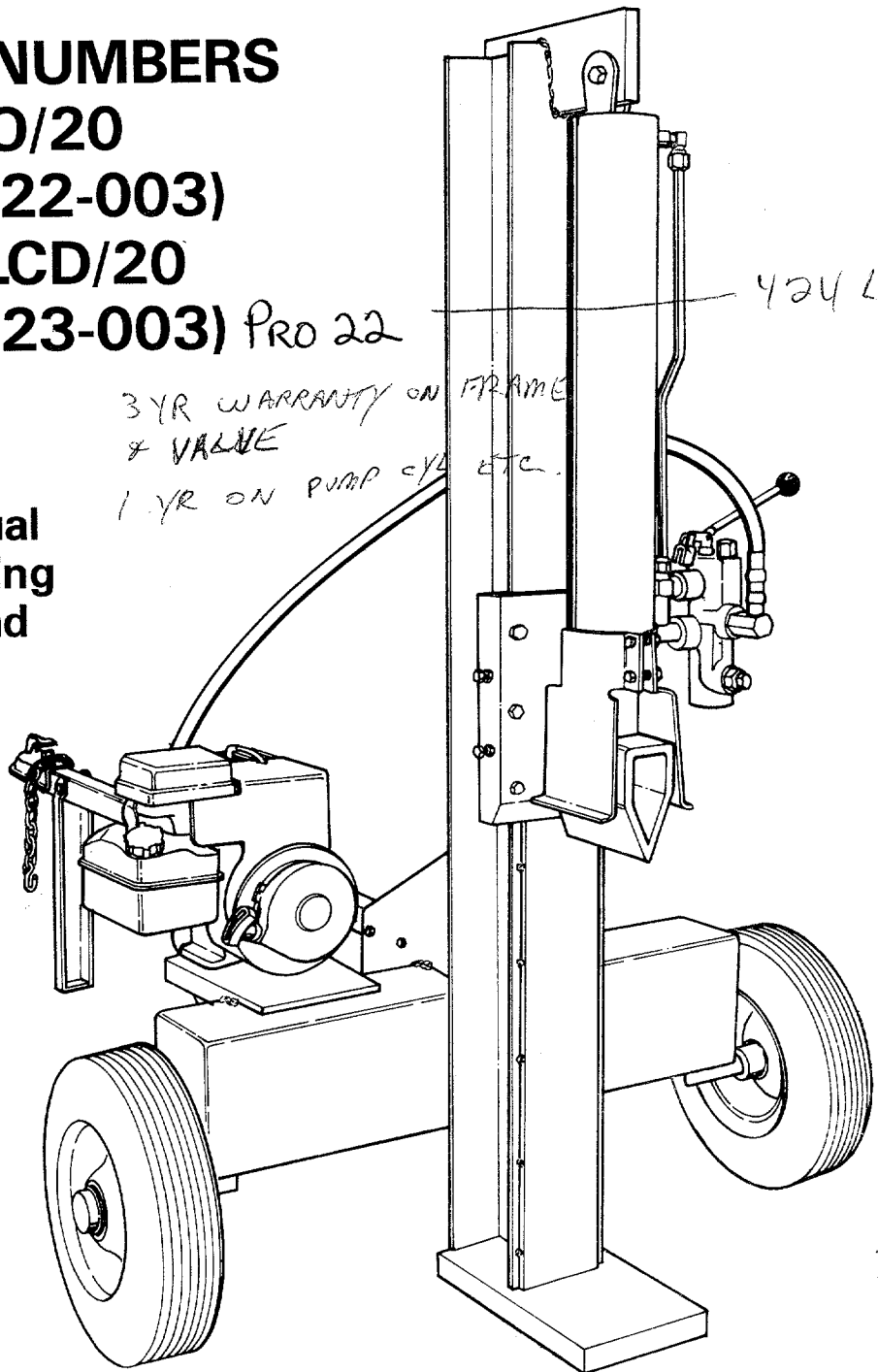

(Model PRO/20 Shown)

770-6254c

DUERR INC. • E. 12122 DAY MOUNT ROAD • MEAD, WA. 99021
(509) 238-6124 - NORM M^c WOLD

-TOM-

INDEX

Rules for Safe Operation	3	Off-Season Storage	13
Assembly Instructions	5	Trouble Shooting Chart	13
Operation	9	Illustrated Parts	14
Adjustments	11	Repair Parts List	1
Maintenance	12	Limited Warranty	Back Cover



This unit is equipped with an internal combustion engine and should not be used on or near any unimproved forest-covered, brush-covered or grass-covered land unless the engine's exhaust system is equipped with a spark arrester meeting applicable local or state laws (if any). If a spark arrester is used, it should be maintained in effective working order by the operator.

In the State of California the above is required by law (Section 4442 of the California Public Resources Code). Other states may have similar laws. Federal laws apply on federal lands. A spark arrester for the muffler is available through your nearest engine authorized service center or through DUERR INC. Order Briggs and Stratton service part number 392390.

IMPORTANT

RULES FOR SAFE OPERATION

THIS SYMBOL POINTS OUT IMPORTANT SAFETY INSTRUCTIONS WHICH, IF NOT FOLLOWED, COULD ENDANGER THE PERSONAL SAFETY AND/OR PROPERTY OF YOURSELF AND OTHERS. READ AND FOLLOW ALL INSTRUCTIONS IN THIS MANUAL BEFORE ATTEMPTING TO OPERATE YOUR LOG SPLITTER. FAILURE TO COMPLY WITH THESE INSTRUCTIONS MAY RESULT IN PERSONAL INJURY. WHEN YOU SEE THIS SYMBOL —  **HEED ITS WARNING.**



DANGER

Your log splitter was built to be operated according to the rules for safe operation in this manual. As with any type of power equipment, carelessness or error on the part of the operator can result in serious injury. If you violate any of these rules, you may cause serious injury to yourself or others.



TRAINING

1. Before operating this splitter, read and understand this manual completely. Become familiar with it for your own safety. To fail to do so may cause serious injury. Do not allow anyone to operate your splitter who has not read this manual. Keep this manual in a safe place for future and regular reference and for ordering replacement parts.
2. Never use your splitter for any other purpose than splitting wood. It is designed for this use and any other use may cause an injury. Your log splitter is a precision piece of power equipment, not a playtoy. Therefore, exercise extreme caution at all times.
3. Never allow children to operate your log splitter. Do not allow adults to operate it without proper instruction. Only persons well acquainted with these rules of safe operation should be allowed to use your log splitter.
4. Only the operator is to be near your log splitter during use. Keep all others, including pets and children, a minimum of 20 feet away from your work zone. Flying wood can be hazardous. If a helper is assisting in loading logs, never activate the control until the helper is clear of the area. More accidents occur when more than one person operates the log splitter than at any other time.
5. No one should operate this unit while intoxicated or while taking medication that impairs the senses or reactions. A clear mind is essential for safety. Never allow a person who is tired or otherwise not alert to use your splitter.



PREPARATION

1. Never wear loose clothing or jewelry that can be caught by moving parts of your log splitter and pull you into it. Keep clothing away from all moving parts of your log splitter.
2. Wear proper head gear to keep hair away from moving parts. Always wear protective hearing devices as needed.
3. Always wear safety shoes. A dropped log can seriously injure your foot.
4. Always wear safety glasses or goggles while operating your splitter. A piece of splitting log could fly off and hit your eyes.
5. If you wear gloves, be sure they are tight fitting without loose cuffs or draw strings.
6. Use your log splitter in daylight, or under good artificial light.

7. Never operate your splitter on slippery, wet muddy or icy surfaces. Safe footing is essential in preventing accidents. Never operate your splitter while attached to a towing vehicle.
8. Only operate your splitter on level ground and not on the side of a hill. It could tip, or rolling logs or poor footing could cause an accident. Operating the splitter on level ground also prevents the spillage of gasoline from the fuel tank.
9. Never attempt to move the log splitter over hilly or uneven terrain without a tow vehicle or adequate help.
10. Always block the wheels to prevent movement of log splitter while in operation.
11. Check the fuel before starting the engine. Gasoline is an extremely flammable fuel. Do not fill the gasoline tank indoors, when the engine is running, or while the engine is still hot. Replace gasoline cap securely and wipe off any spilled gasoline before starting the engine as it may cause a fire or explosion.
12. Both ends of each log must be cut as square as possible to help prevent the log from riding out of the splitter during operation.



OPERATION

1. Stand behind the reservoir tank when operating. See illustration.

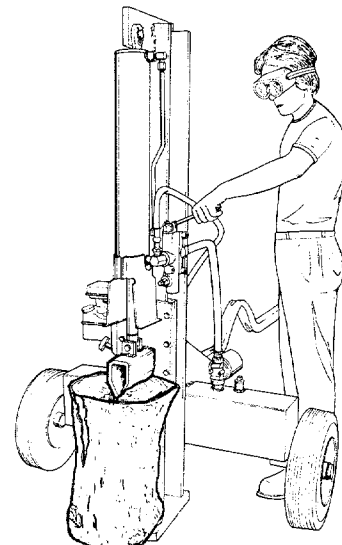

2. Know how to stop the unit and disengage the controls.
3. Never place hands or feet between log and splitting wedge or between log and end plate during forward or reverse stroke. To do so may result in crushed or amputated fingers or toes, or worse, you may lose an arm or foot.
4. Do not straddle the splitter when using it. A slip in any position could result in a serious injury.
5. Do not step over your log splitter when the engine is running. You may trip or accidentally activate the splitting wedge if you step over. If you need to get to the other side, walk around.
6. Never try to split two logs on top of each other. One may fly out and injure you.
7. When loading the log splitter, place your hands on the side of the log, not at the ends. Never attempt to load your splitter while the splitting wedge is in motion. You may get caught by the wedge and injured.
8. Only use your hand to operate the splitting wedge or control lever. Never use your foot or a rope or any other extension device. This could result in your ability to stop your splitter quickly enough and cause injury.
9. Always keep fingers away from any cracks that open in the log during splitting operation. They can quickly close and pinch or amputate your fingers.
10. Never attempt to split wood across the grain. Some types of wood may burst or fly out of your splitter and result in injury to you or a bystander.
11. For logs that are not cut square, the longest portion of the log should be rotated down and the most square end placed against the splitting wedge.
12. Keep your work area clean. Immediately remove split wood around your splitter so that you do not stumble over it. Clean chips and dirt off end plate (wood platform) after each log is split, or whenever necessary to maintain flat contact between wood and end plate (platform).
13. Never move the log splitter while the engine is running.
14. Never leave your log splitter unattended with the engine running. Shut off the engine if you are leaving your splitter, even for a short period of time. Someone could accidentally activate the splitting wedge and be injured.
15. Do not run engine in an enclosed area. Exhaust gases contain carbon monoxide. This odorless gas can be deadly when inhaled.
16. Be careful not to touch the muffler after the engine has been running as it is HOT.
17. If the equipment should start to vibrate abnormally, stop the engine and check immediately for the cause. Vibration is generally a warning of trouble.
18. When cleaning, repairing or inspecting, make certain all moving parts have stopped. Disconnect the spark plug wire and keep the wire away from the plug to prevent accidental starting.
3. Replace all damaged or worn parts such as hydraulic hoses and fittings immediately with manufacturer approved replacement parts.
4. Do not change the engine governor settings or overspeed the engine. This increases the hazard of personal injury. The maximum engine speed is preset by the manufacturer and is within safety limits.
5. Do not alter your splitter in any manner such as attaching a rope or extension to the control lever or adding to the width or height of the wedge. Such alterations may cause your splitter to be unsafe.
6. Perform all recommended maintenance procedures before you use your splitter.
7. Do not service or repair your log splitter without disconnecting the spark plug wire.
8. Never store the equipment with gasoline in the tank inside of a building where ignition sources are present, such as hot water and space heaters, clothes dryers and the like. Allow the engine to cool before storing in any enclosure.
9. Always store gasoline in an approved, tightly sealed container. Store the container in a cool, dry place. Do not store in a building where ignition sources are present.
10. To reduce fire hazard, keep engine free of grass, leaves, wood chips, and excessive grease and oil.
11. The hydraulic system of your log splitter requires careful inspection, along with the mechanical parts. Be sure to replace frayed, kinked, or otherwise damaged hydraulic components.
12. Fluid escaping from a very small hole can be almost invisible. Do not check for leaks with your hand. Escaping fluid under pressure can have sufficient force to penetrate skin, causing serious personal injury. Leaks can be located by passing a piece of cardboard or wood over the suspected leak and looking for discoloration.
13. Should it become necessary to loosen or remove any hydraulic fitting or line, be sure to relieve all pressure by shutting off the engine and moving the control handle back and forth several times.
14. Do not remove the cap from the hydraulic tank or reservoir while your log splitter is running. Hot oil under pressure could cause injury.
15. The pressure relief valve on your splitter is preset at the factory. Do not adjust the valve. Only a qualified service technician should perform this adjustment.
16. Completely drain fuel tank prior to storage. This guards against accumulation of fuel fumes which could result in a fire hazard.
17. Never store log splitter outside without a waterproof cover. Rain will cause rust on the inside of the cylinder.



MAINTENANCE AND STORAGE

1. Do not operate your splitter in poor mechanical condition or when in need of repair.
2. Periodically check that all nuts, bolts, screws, hose clamps and hydraulic fittings are tight to be sure equipment is in safe working condition. Where appropriate, check all safety guards and shields to be sure they are in the proper position. Never operate your splitter with safety guards, shields or other protective features removed. These safety devices are for your protection.



TOWING

1. This unit should not be towed on any street, highway or public road without checking the existing federal, local or state vehicle requirements. Any licensing or modifications such as taillights, etc., needed to comply with the existing federal, local or state vehicle requirements is the sole responsibility of the purchaser.
2. Before towing, be certain the log splitter is correctly and securely attached to the towing vehicle, and the safety chains are in place. Leave slack in chains for turn allowance.
3. Do not allow anyone to sit or ride on your splitter. They can easily fall off and be seriously injured.

➔ IMPORTANT

This unit has been shipped without gasoline or oil in the engine. After assembly, refer to separate engine manual for proper fuel and engine oil information.

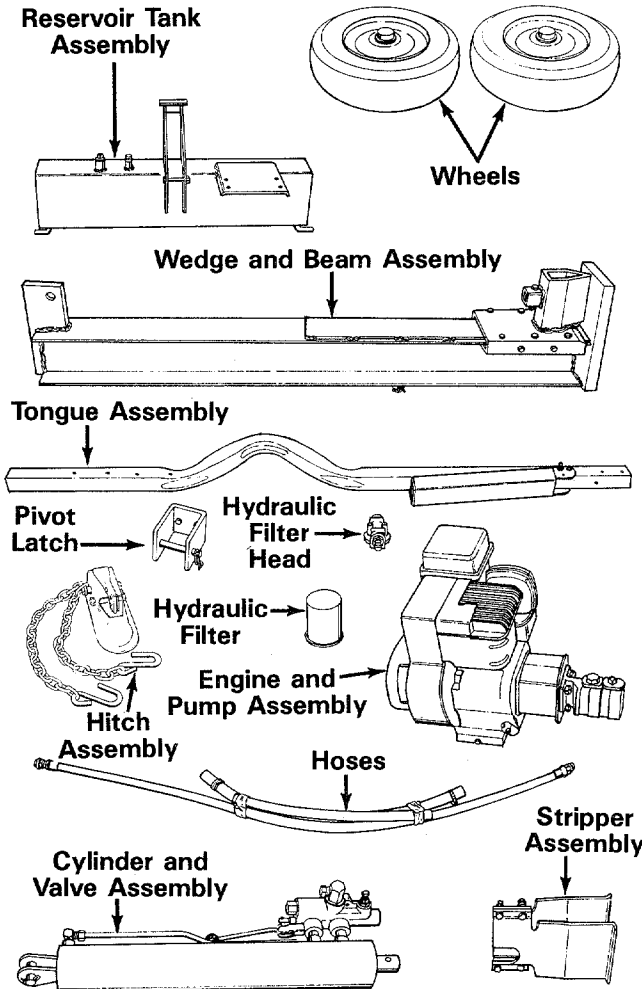

FIGURE 1

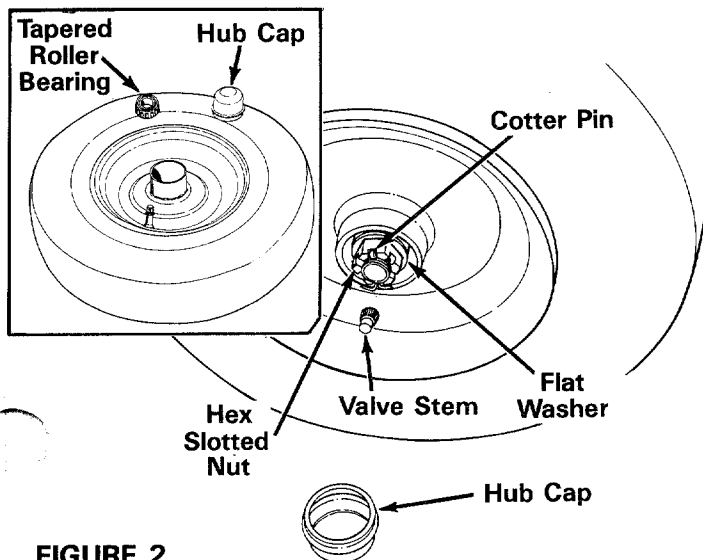

FIGURE 2

ASSEMBLY

UNPACKING

Remove all parts from the carton. Make certain all parts and literature have been removed from the carton before the carton is discarded.

➔ NOTE

All hardware for assembly of the log splitter has been placed in position on the various parts.

Other Materials Required for Assembly:

Wheel Bearing Grease

Loc-tite Hydraulic Sealer or Equivalent

Engine Oil

Unleaded Gasoline (regular grade gasoline is an acceptable substitute)

Approximately 6-1/2 Gallons of 10 Weight AW type fluid or Dexron II Automatic Transmission Fluid

Loose Parts in Carton: (See figure 1)

- (1) Reservoir Tank Assembly
- (2) Wheels
- (1) Wedge and Beam Assembly
- (1) Tongue Assembly
- (1) Pivot Latch
- (1) Hitch Assembly
- (1) Engine and Pump Assembly
- (3) Hoses (taped together)
- (1) Cylinder and Valve Assembly
- (1) Stripper Assembly (two halves)
- (2) Fenders (Not Shown—Model 424/LCD/20)
- (1) Filter Head*
- (1) Hydraulic Filter*

* May be already assembled to the reservoir tank.

INSTALLATION OF WHEELS

Attach the wheels to the reservoir tank as follows. See figure 2.

1. Pry off the hub caps which are attached to the wheels. Remove one tapered roller bearing from inside each wheel. See inset, figure 2.
2. Remove the cotter pin, hex slotted nut and one flat washer from each axle (leave spacers and two flat washers in place on axles).
3. Place one wheel on each axle, with the **valve stem facing outward**.
4. Pack the tapered roller bearings with wheel bearing grease, and place one on each axle.
5. Place one flat washer removed in step 2 on each axle. Secure with hex slotted nut. Tighten slotted nut until snug, then back off approximately 1/3 turn or until one of the slots on the slotted nut lines up with the hole in the axle.
6. Check the assembly of the wheels. There should be no side to side play, and the wheels should spin freely.
7. Place hub caps in position on wheels and tap on with a rubber mallet or plastic hammer.

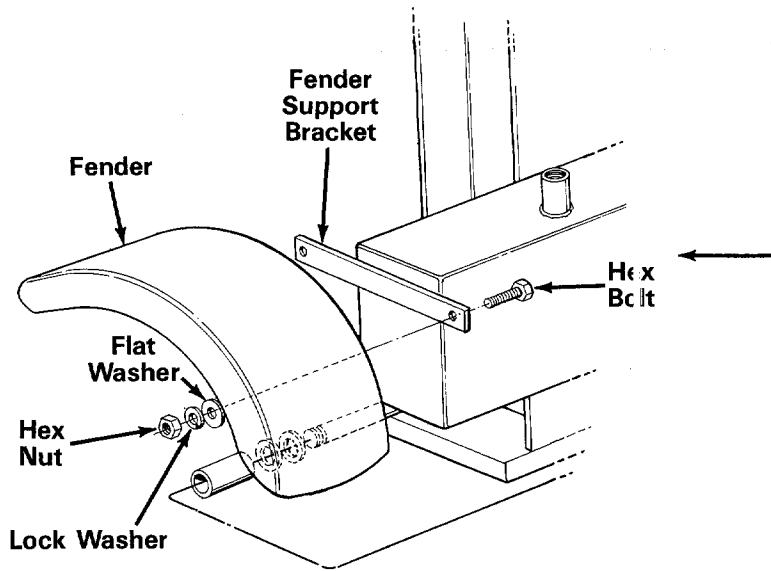

FIGURE 3

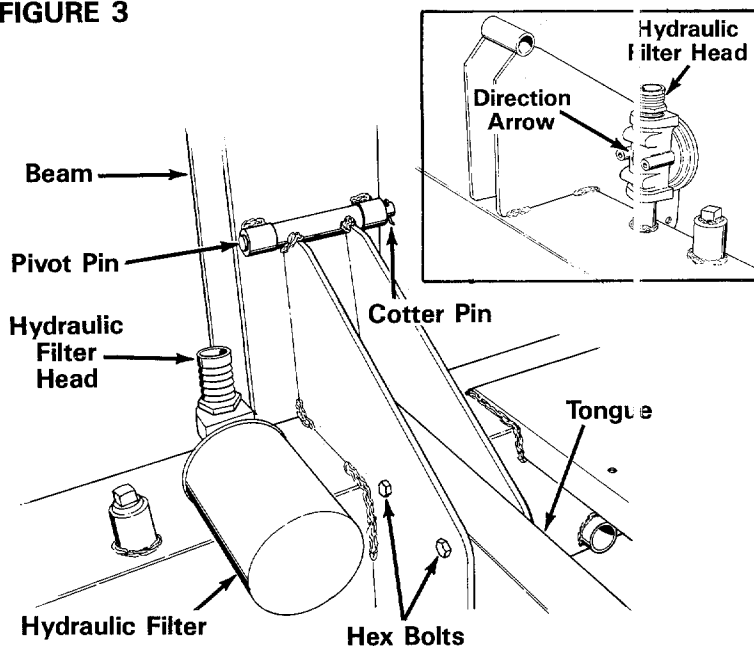

FIGURE 4

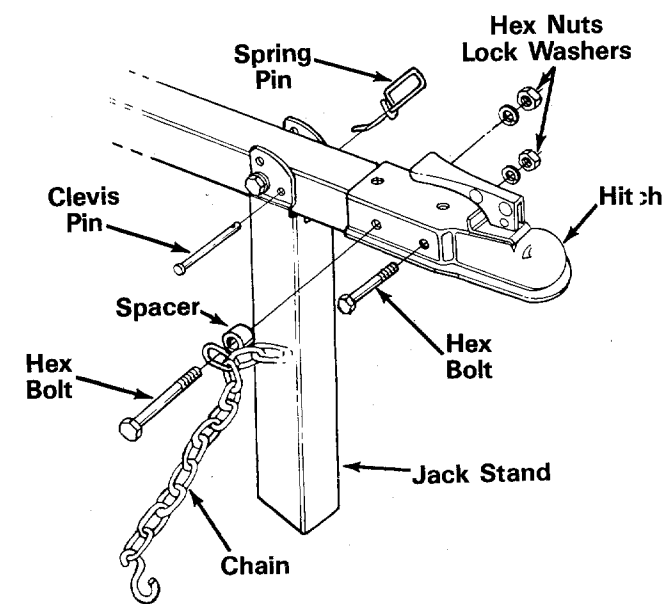

FIGURE 5

ATTACHING THE FENDERS (Model 424/LCD/20)

1. Remove the hex nuts, lock washers, flat washers and hex bolts from the fender support brackets.
2. Place the fenders in position against the fender support brackets. Insert hex bolts through holes in support brackets and fenders. Secure with flat washers, lock washers and hex nuts. See figure 3.
3. Tighten securely.

INSTALLING THE HYDRAULIC FILTER (If not already assembled)

If the hydraulic filter head and hydraulic filter have not already been installed on the reservoir tank at the factory, proceed as follows.

1. Place Loc-tite hydraulic sealer or equivalent on the threads on the fitting on top of the reservoir tank.
2. Thread hydraulic filter head onto fitting on top of the reservoir tank as shown in figure 4, inset. The direction arrow on the filter head must point down toward the tank. Filter head must be positioned as shown.
3. Oil the gasket on the top of the hydraulic filter using automatic transmission fluid. Thread the hydraulic filter onto the hydraulic filter head as shown in figure 4. Tighten by hand.

ATTACHING THE WEDGE AND BEAM ASSEMBLY

1. The beam has been shipped with the wedge down against the end plate, and tightened in this position. Stand the beam upright, making certain the wedge is down against the end of the beam.



WARNING

Do not attempt to stand beam upright if the wedge is not against the end of the beam, to avoid personal injury. (Move wedge so it is against end of beam).

2. Remove the pivot pin from the bracket on the beam by removing the cotter pin. See figure 4.
3. Roll the reservoir tank in position against the beam. Secure beam to tank using pivot pin and cotter pin just removed.

ATTACHING TONGUE TO RESERVOIR TANK

1. The tongue is shipped with the jack stand already attached to the tongue. The jack stand is in the transport position. Remove the spring pin and clevis pin. Pivot the jack stand to the operating position and replace the clevis pin and spring pin. See figure 5.
2. Remove the two hex bolts, lock washers and hex nuts on the front of the reservoir tank. Place the tongue in position and secure with hardware just removed. See figure 4.

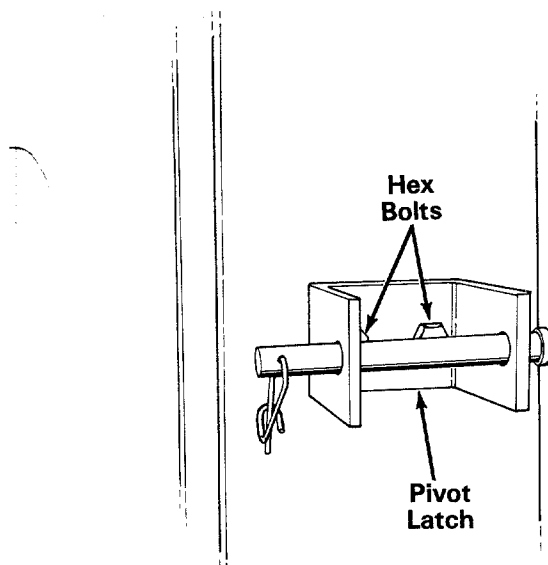

FIGURE 6

INSTALLING THE HITCH

1. Remove the two long hex bolts, lock washers and hex nuts which are assembled through the sides of the hitch. Do not remove the chain and spacer from the one hex bolt.
2. Place the hitch in position on the end of the tongue. Secure with hardware just removed. See figure 5.

INSTALLATION OF PIVOT LATCH

1. Remove the two hex bolts, lock washers and hex nuts on the pivot latch.
2. With the beam still in the upright position, place the pivot latch on the beam as shown in figure 6. Secure with hex bolts, lock washers and hex nuts just removed. The heads of the bolts must be inside the pivot latch.

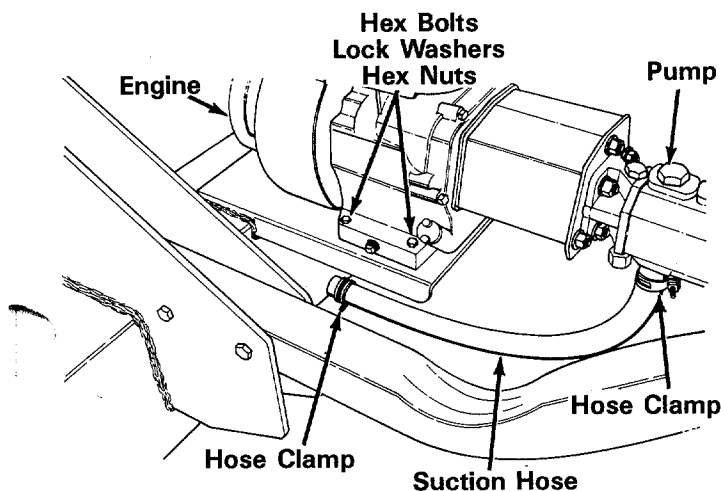

FIGURE 7

ATTACHING THE ENGINE AND PUMP ASSEMBLY

1. Remove the four hex bolts, lock washers and hex nuts from the engine mounting bracket (attached to the reservoir tank).
2. Place the engine and pump assembly in position as shown in figure 7. Secure with hardware just removed. **Tighten securely.**

ATTACHING THE SUCTION HOSE

1. The suction hose is 3/4" by 20" long. Loosen the hose clamps on each end of the hose using a screwdriver.
2. Attach one end of the hose to the fitting on the bottom of the pump. Attach the other end to the reservoir tank. See figure 7.
3. Place hose clamps at the base of the fittings, and **tighten securely.**

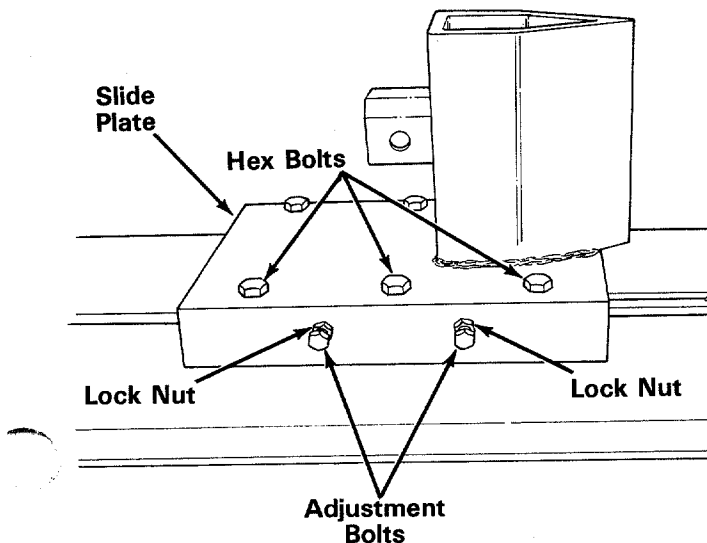

FIGURE 8

ADJUSTING THE SPLITTING WEDGE

The adjustment bolts on the splitting wedge were tightened at the factory to hold the wedge in a stationary position for shipping. Adjust these bolts as follows. See figure 8.

1. Loosen the three hex bolts on top of the slide plate (beneath the splitting wedge).
2. Back the two adjustment bolts on the side of the slide plate out **slowly** until the wedge assembly will slide on the beam. Tighten the lock nuts securely against the base of the slide plate to hold the bolts in this position.
3. Retighten the three hex bolts on top of the slide plate.

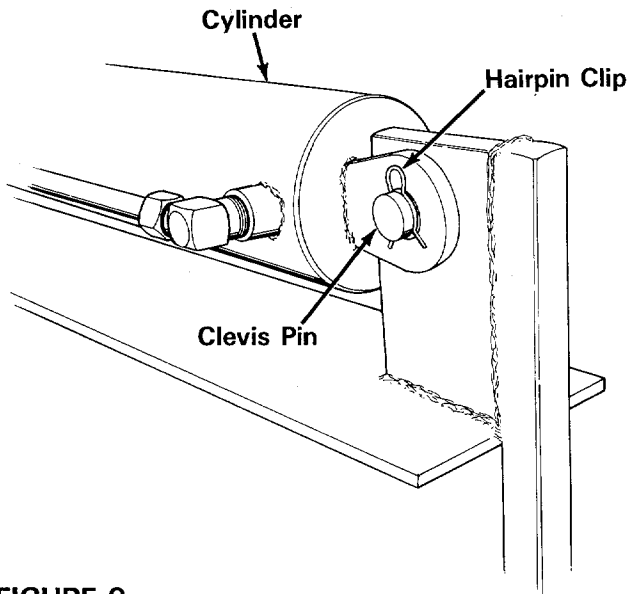

FIGURE 9

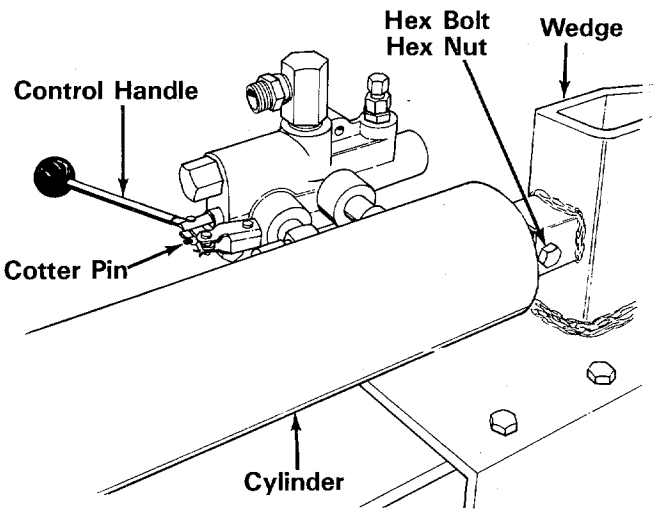

FIGURE 10

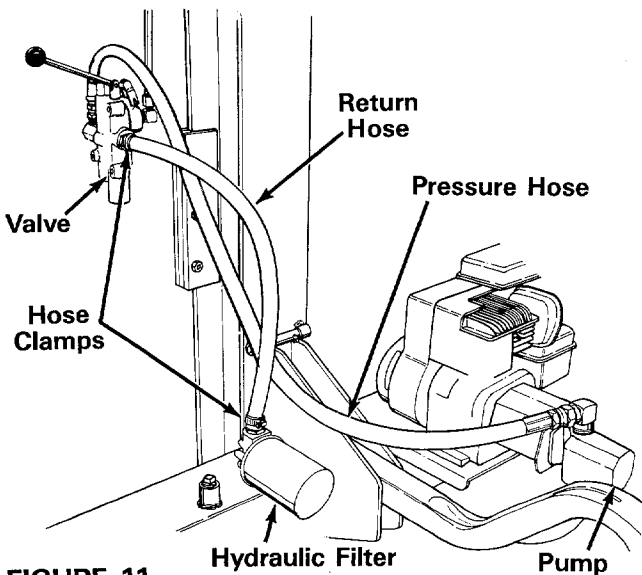

FIGURE 11

INSTALLING THE CYLINDER AND VALVE ASSEMBLY

1. Lower the beam to the horizontal position as follows.
 - a. Remove the spring pin from the pivot latch on the back side of the beam. Remove the clevis pin.
 - b. Lower the beam so the tongue is inside the pivot latch. Secure with clevis pin and spring pin.
2. Remove one hairpin clip from the clevis pin on the end of the cylinder. Place the cylinder in position on the log splitter, and secure with clevis pin and hairpin clip just removed. See figure 9.
3. Remove the large hex bolt, lock washer and hex nut on the end of the wedge assembly. Secure the other end of the cylinder assembly with the hardware just removed. See figure 10.

ATTACHING THE CONTROL HANDLE

The bottom of the control handle is already attached to the valve with a cotter pin. Remove the second cotter pin which is attached to the valve only. Place the handle in position and secure using the second cotter pin. See figure 10.

INSTALLING THE RETURN HOSE

1. Move the beam to the operating (upright) position by removing the spring pin and clevis pin from the pivot latch. Place the beam upright, and replace clevis pin and spring pin in pivot latch for safekeeping.
2. The return hose is 3/4" by 30" long. Loosen the hose clamps on each end of the hose using a screwdriver.
3. Attach one end of the hose to the fitting on the hydraulic filter head (located on top of the reservoir tank). Attach the other end to the fitting beneath the valve. See figure 11.
4. Make certain the hose is adjusted so it is relaxed and in the proper position (do not allow hose to twist). Place hose clamps at the base of the fittings, and **tighten securely**.

INSTALLING THE PRESSURE HOSE

1. The pressure hose is 1/2" x 54" long. Place Loc-tite hydraulic sealer or equivalent on the threads on both ends of the pressure hose.
2. Thread one end of the hose into the fitting on top of the pump. See figure 11.
3. Thread the other end of the hose into the fitting on top of the valve. Adjust hose so it is relaxed and in the proper position as shown in figure 11. Do not allow hose to twist. Then tighten securely.

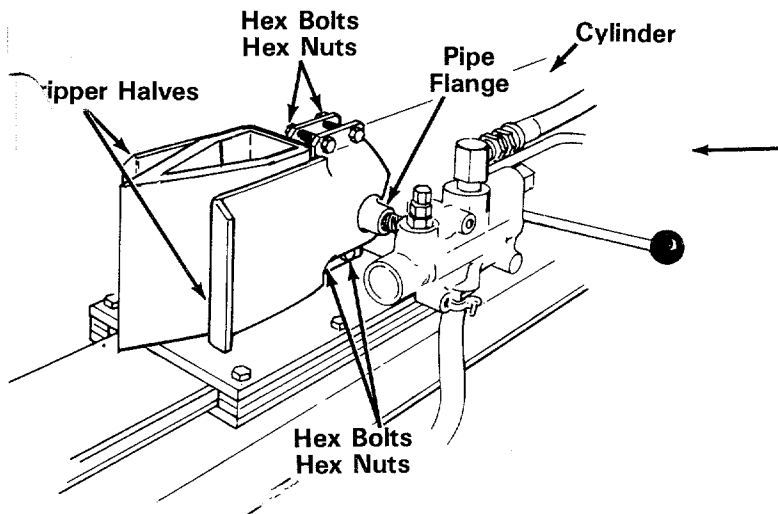

FIGURE 12

ATTACHING THE STRIPPER ASSEMBLY

1. Remove the four hex bolts and hex lock nuts which are holding the two stripper halves together.
2. Slip one stripper half over the pipe flange on the cylinder. Place the other stripper half on the other side of the cylinder. See figure 12.
3. Put two hex bolts through the top of the stripper halves, and start hex nuts on the bolts. Start the hex bolts and nuts through the bottom of the stripper halves in the same manner.
4. Make certain the cylinder is against the stops located on the inside of the stripper halves. Tighten all four nuts and bolts **equally**.

FINAL ASSEMBLY

1. Make certain all nuts, bolts and hose clamps are tightened securely.
2. Before operating the log splitter, make certain to follow the "Initial Preparation" instructions in the Operation section.

OPERATION

INITIAL PREPARATION

1. On a firm, level surface, remove the spring pin and clevis pin from the pivot latch. Place the beam in the vertical position. Replace clevis pin and spring pin in pivot latch for safekeeping. Make certain the beam is straight up and down, against the reservoir tank.
2. Service engine with gasoline and oil as instructed in the separate engine manual packed with your log splitter.
3. Lubricate the beam area where beam will slide with engine oil (**DO NOT USE GREASE**). Make certain to oil both front and back of the beam face. Pour some oil directly into the wedge assembly.
4. Fill the reservoir tank as follows.
 - a. Remove reservoir vent plug. See figure 13. Using 10 Weight AW type fluid or Dexron II automatic transmission fluid, fill reservoir to the top. Replace vent plug securely.
 - b. Disconnect the spark plug wire and ground against the engine. Prime the pump by pulling the recoil starter, to turn the engine over, approximately 10 times. Reconnect the spark plug wire.
 - c. Start engine. Use the control handle to extend the wedge to the far extended position. Leave the wedge in this position (do not retract).
 - d. Refill tank to within 1-1/2" to 2" from the top of the tank. Total capacity of system is approximately 6-1/2 gallons.
 - e. Now retract the wedge. Extend and retract the wedge fully 10 to 12 complete cycles to remove trapped air in the system (system is "self-bleeding").

- f. **Refill the reservoir** to within 1-1/2" to 2" from the top of the tank. Much of the original fluid has been drawn into the cylinder and hoses. Make certain to refill the reservoir, to prevent extreme damage to the hydraulic pump. Failure to refill the tank will **void your warranty**.

NOTE

Some fluid may overflow from the vent plug as the system builds heat and the fluid expands and seeks its own level.



WARNING

Do not operate the log splitter without the proper amount of transmission fluid in the reservoir tank.

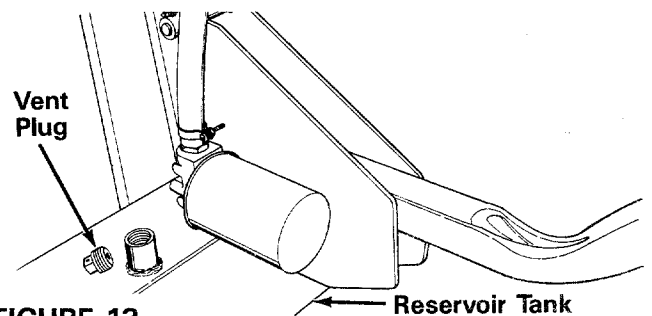

FIGURE 13

BEFORE STARTING

Before each use, check the following:

1. On a firm level surface, remove the spring pin and clevis pin from the pivot latch. Place the beam in the vertical position. Replace clevis pin and spring pin in pivot latch for safekeeping. Make certain the beam is straight up and down, against the reservoir tank.

- Remove the vent plug and check the fluid level. Fluid level should be 1-1/2" to 2" from the top of the tank.

➡ IMPORTANT

Reservoir tank must be full as instructed. Low fluid level will damage the pump and **void your warranty.**

- Lubricate the beam area where beam will slide with engine oil (DO NOT USE GREASE). Make certain to oil both front and back of the beam face. Pour some oil directly into the wedge assembly.
- Fill gasoline tank as instructed in the separate engine manual.
- Make certain wearing surfaces of beam are lubricated with engine oil.

TO START ENGINE

- Place throttle control lever on the engine in FAST position. See figure 14.
- Place choke lever in CHOKE position.

➡ NOTE

A warm engine may not require choking.

- Grasp starter handle and pull rope out slowly until engine reaches start of compression cycle (rope will pull slightly harder at this point). Let the rope rewind slowly.
- Pull rope with a rapid, continuous, full arm stroke. Keep a firm grip on the starter handle. Let the rope rewind slowly. Do not let starter handle snap back against starter.
- Repeat preceding instructions 3 and 4 until engine fires. When engine starts, move choke lever halfway between CHOKE and RUN.
- Move throttle control lever to IDLE position for a few minutes warm-up. Gradually move choke lever to RUN position as engine warms up.

➡ NOTE

In order to idle smoothly, a new engine may require 3 to 5 minutes running above slow idle speed. Idle speed has been adjusted to be correct after this break-in period.

- If weather is cold, run wedge up and down beam 6 to 8 times to circulate the hydraulic fluid, which will warm and thin the fluid.

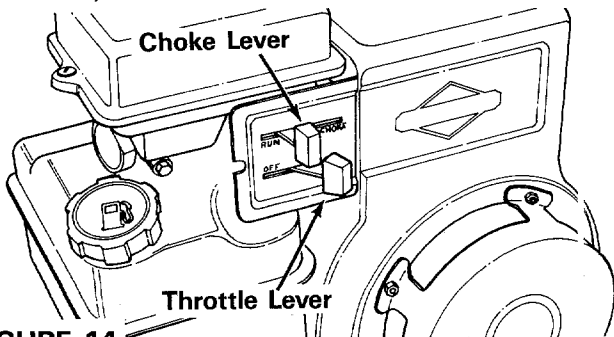

FIGURE 14

TO STOP ENGINE

- Move throttle control lever to OFF position.
- Disconnect spark plug wire from spark plug and ground against the engine to prevent accidental starting while equipment is unattended.

USING THE LOG SPLITTER



Use the log splitter only on a level, hard surface. Never stand next to the splitting wedge when operating the log splitter. Always stand behind the reservoir tank. See figure 15. Never attempt to cut a log in half sideways. Always split the log lengthwise.

The log splitter is designed to be used in the vertical position only. Do not split logs with the beam horizontal. Maximum length of log to be split is 24".

The control handle has three positions:

FORWARD (push the control handle down) — Splitting wedge moves toward the end plate. Control handle will return to neutral position as soon as handle is released.

NEUTRAL (Middle position) — Splitting wedge stops in place.

REVERSE (Push the control handle upward) — Splitting wedge returns. The control handle will lock in the reverse position, and will return to neutral automatically when the reverse stroke is complete.

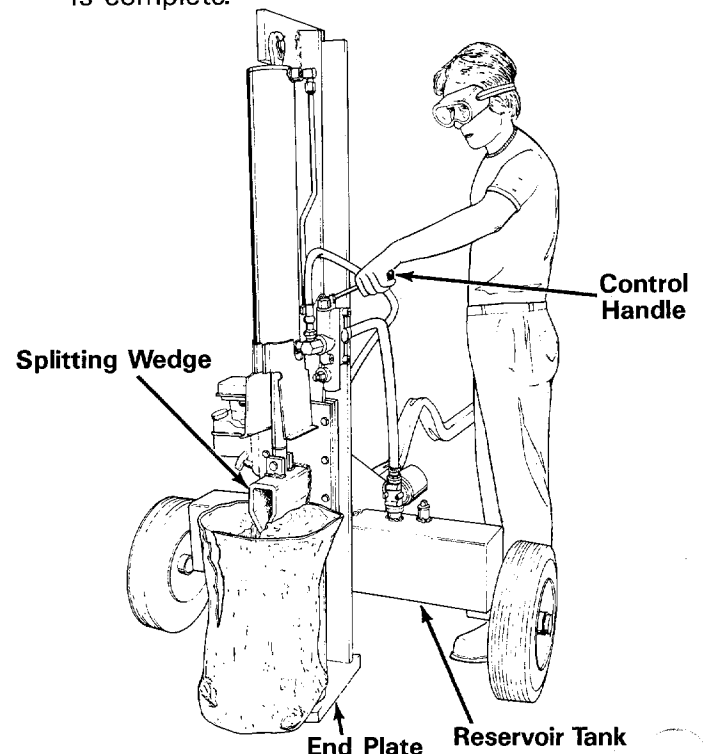

FIGURE 15 - Model PRO/20 Shown

TO OPERATE LOG SPLITTER:

- Set throttle as maximum speed (3450-3600 RPM).

2. Place the log upright, on top of end plate.
3. Press the control handle down (forward position) until the splitting wedge just contacts the log. Release the control handle.
4. **STEP BEHIND THE RESERVOIR TANK** (see figure 15) and press the control handle down until the log is split.
5. Move the control handle upward to return the splitting wedge.

The wedge should take approximately 14 seconds to make a complete cycle. This speed may vary depending on throttle setting and temperature of hydraulic fluid.

NOTE

If the control handle kicks out of reverse too soon, it can be adjusted. Refer to Adjustment section of this manual.

TO TRANSPORT LOG SPLITTER

1. Lower the beam to its horizontal position. Make certain the pivot latch is latched securely with the clevis pin and spring pin.
2. Remove the spring pin and clevis pin which secure the jack stand. Pivot it up against the tongue, and secure with spring pin and clevis pin.
3. Attach the hitch to a towing vehicle, making certain to latch securely. Attach the safety chains to the towing vehicle.

ADJUSTMENTS

SPLITTING WEDGE

As normal wear occurs, periodically adjust the bolts on the slide plate (beneath the splitting wedge) as follows to eliminate the excess space between the wedge plate and the beam. Refer to figure 8.

1. Loosen the three hex bolts on top of the slide plate (beneath the splitting wedge).
2. Back the two adjustment bolts on the side of the slide plate out **slowly** until the wedge assembly will slide on the beam. Tighten the lock nuts securely against the base of the slide plate to hold the bolts in this position.
3. Retighten the three hex bolts on top of the slide plate.

CARBURETOR ADJUSTMENT



WARNING

If any adjustments are made to the engine while the engine is running (e.g., carburetor), keep clear of all moving parts. Be careful of heated surfaces and muffler.

Minor carburetor adjustment may be required to compensate for differences in fuel, temperature, altitude and load. Improper adjustment will cause stalling when splitter is under load, hard starting and higher fuel consumption.

Refer to the separate engine manual packed with your log splitter for carburetor adjustment information.

REVERSE LOCKOUT ADJUSTMENT



WARNING

This adjustment should be made by an authorized service dealer only.

The spring detent for the reverse lockout can be adjusted by turning the adjustment screw shown in figure 16. If it is not tight enough, the control handle will kick out of reverse too soon, before the return stroke is completed. If it is adjusted too tight, the control handle will not kick out of reverse, and could cause damage to the pump, hoses, and serious personal injury.

If adjustment is needed, an authorized service dealer should make the adjustment using a pressure gauge as shown in figure 16. The reverse lockout should kick out at 1400 p.s.i.



WARNING

When adjusting the reverse lockout, do not overtighten the adjustment screw to avoid damage to the log splitter and possible serious personal injury.

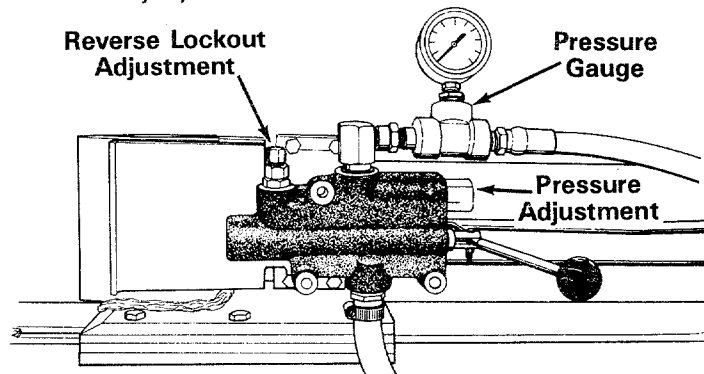

FIGURE 16

PRESSURE ADJUSTMENT



WARNING

This adjustment should be made by an authorized service dealer only.

The pressure is preset at the factory and should not require adjustment. The pressure should be between 3000 and 3100 p.s.i. An adjustment screw is located on the valve and should be adjusted by an authorized service dealer only, using a pressure gauge as shown in figure 16.

Any adjustment of the pressure without instruction from the factory will automatically void your warranty.

MAINTENANCE



WARNING

Always stop the engine and disconnect the spark plug wire before performing any maintenance or adjustments.

RESERVOIR FLUID

Check the hydraulic fluid level in the log splitter reservoir tank before each use. Fluid level should be 1-1/2" to 2" from the top of the tank.

Change the hydraulic fluid in the reservoir every 100 hours of operation. Disconnect the suction hose from the bottom of the reservoir tank, and drain the fluid into a suitable container. Refill using only 10 W/88 AW type fluid or Dexron II automatic transmission fluid, as instructed in the "Initial Preparation" section of this manual, page 9. Also, make certain to change the hydraulic filter.



NOTE

Drain the fluid and flush the reservoir tank and hoses with kerosene whenever any repair work is performed on the tank, hydraulic pump or valve. Contaminants in the fluid will damage the hydraulic components.



WARNING

Use extreme caution when working with kerosene, as it is an extremely flammable fluid.

HYDRAULIC FILTER

Change the hydraulic filter every 50 hours of operation. Use only a 10 micron hydraulic filter. Order part number 723-0405.

BEAM AND SPLITTING WEDGE

Lubricate both sides of the beam where it contacts the splitting wedge with engine oil before each use to obtain years of service. However, normal wear will occur. The wedge plate on the log splitter is designed so the gibs on the side of the wedge plate can be easily removed and rotated and/or turned over for even wear. Make certain to readjust the adjustment bolts so wedge moves freely, but no excess space exists between the wedge plate and beam.

HOSE CLAMPS

Check the hose clamps on the suction hose (attached to bottom of the pump) for proper tightness before each use. Check the hose clamps on the return hose at least once a season.

ENGINE

Change the engine oil after first 5 hours of operation. Thereafter, change every 25 hours. Check engine oil level every 5 hours, or each time the log splitter is used. Service air cleaner every 25 hours.

Refer to separate engine manual for complete instructions for care and maintenance of the engine.

FLEXIBLE PUMP COUPLER

The flexible pump coupler is a nylon "spider" insert, located between the pump and engine shaft. The alignment is very critical. Over a period of time, the coupler will harden and deteriorate. To replace, remove the engine, slide it back and replace the coupler. **Do not** loosen or remove pump. Replace engine, leaving engine mounting bolts loose. Align coupler, then tighten engine bolts. Make certain coupler is tight.

For a replacement flexible pump coupler, order part number 717-0891.

TIRE PRESSURE

Check sidewall of tire for manufacturer's recommended maximum tire pressure. If this information does not appear on your tire, maximum tire pressure under any circumstances is 30 p.s.i. Equal pressure should be maintained on both tires.

INSTALLATION OF TIRE TO RIM



WARNING

The following procedure must be followed when removing or installing a tire to the rim.

1. Be certain rim is clean and free of rust.
2. Lubricate both the tire and rim generously.
3. Never inflate to over 30 p.s.i. to seat beads. Excessive pressure when seating beads may cause tire/rim assembly to burst with force sufficient to cause serious injury.

OFF-SEASON STORAGE

If the machine is to be inoperative for a period longer than 30 days, prepare for storage as follows.

1. Clean the engine and the entire unit thoroughly. Wipe the entire machine with an oiled rag to protect the surfaces.
3. Refer to the engine manual for correct engine storage instructions. The engine must be completely drained of fuel to prevent gum deposits from forming on essential carburetor parts and fuel tank.
4. The tongue can be removed and reattached in an upright position as shown in figure 17 to take less space when storing.
5. Store unit in a clean, dry area.

→ NOTE

When storing any type of power equipment in an unventilated or metal storage shed, care should be taken to rustproof the equipment. Using a light oil or silicone, coat the equipment, especially all moving parts.

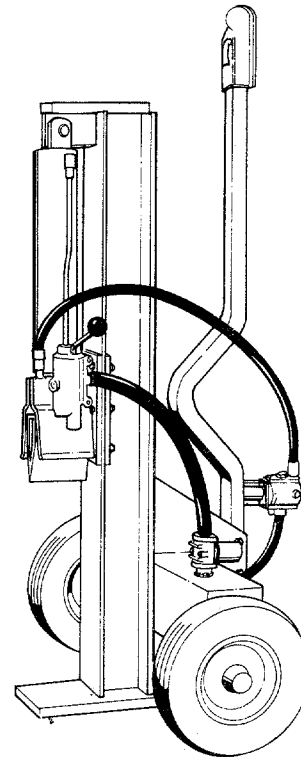

FIGURE 17

TROUBLE SHOOTING CHART

SYMPTOM	POSSIBLE CAUSE(S)	SOLUTION
1. Engine fails to start	A. Check fuel tank for gas. B. Spark plug lead wire disconnected. C. Faulty spark plug.	A. Fill tank if empty. B. Connect lead wire. C. Clean, adjust gap or replace.
2. Hard starting or loss of power	A. Spark plug wire loose. B. Dirty air cleaner.	A. Connect and tighten spark plug wire. B. Clean air cleaner as described in engine manual.
3. Engine overheats	A. Carburetor not adjusted properly. B. Air flow restricted. C. Engine oil level low.	A. Adjust carburetor. See engine manual. B. Remove blower housing and clean as described in the engine manual. C. Fill crankcase with the proper oil.
4. Will not split logs	A. Reservoir fluid level low. B. Pump setting incorrect.	A. Check and fill reservoir tank as instructed in Operation Section. B. Adjust pump setting to between 3,000 and 3,100 p.s.i.*
5. Leaking cylinder	A. Broken seals. B. Scored cylinder.	A. Replace seals.* B. Replace cylinder.*

NOTE: For repairs beyond minor adjustments, please contact your local service dealer.
*Should be performed by an authorized service dealer only.

PRO/20 (Model 622) } 6 1/2 GAL 10 WT AW FLUID OR DEXRON II
 PRO/22 (Model 623) } SOME UNITS 15 GAL. TANKS

PRESSURE TESTER
 753-0479

714-0203
 711-0821

720-0231

747-0709

SUPPLIED BY PRINCE HYDRAULICS

0192
 737-0232

DRAIN TANK
 C FROM HERE

714-0229
 PUMP
 KEY

WELDED TO TANK

SEE BACK PAGE OF MANUAL
 11-29-89

721-0168 → grease
 (1 PER UNIT) retainer

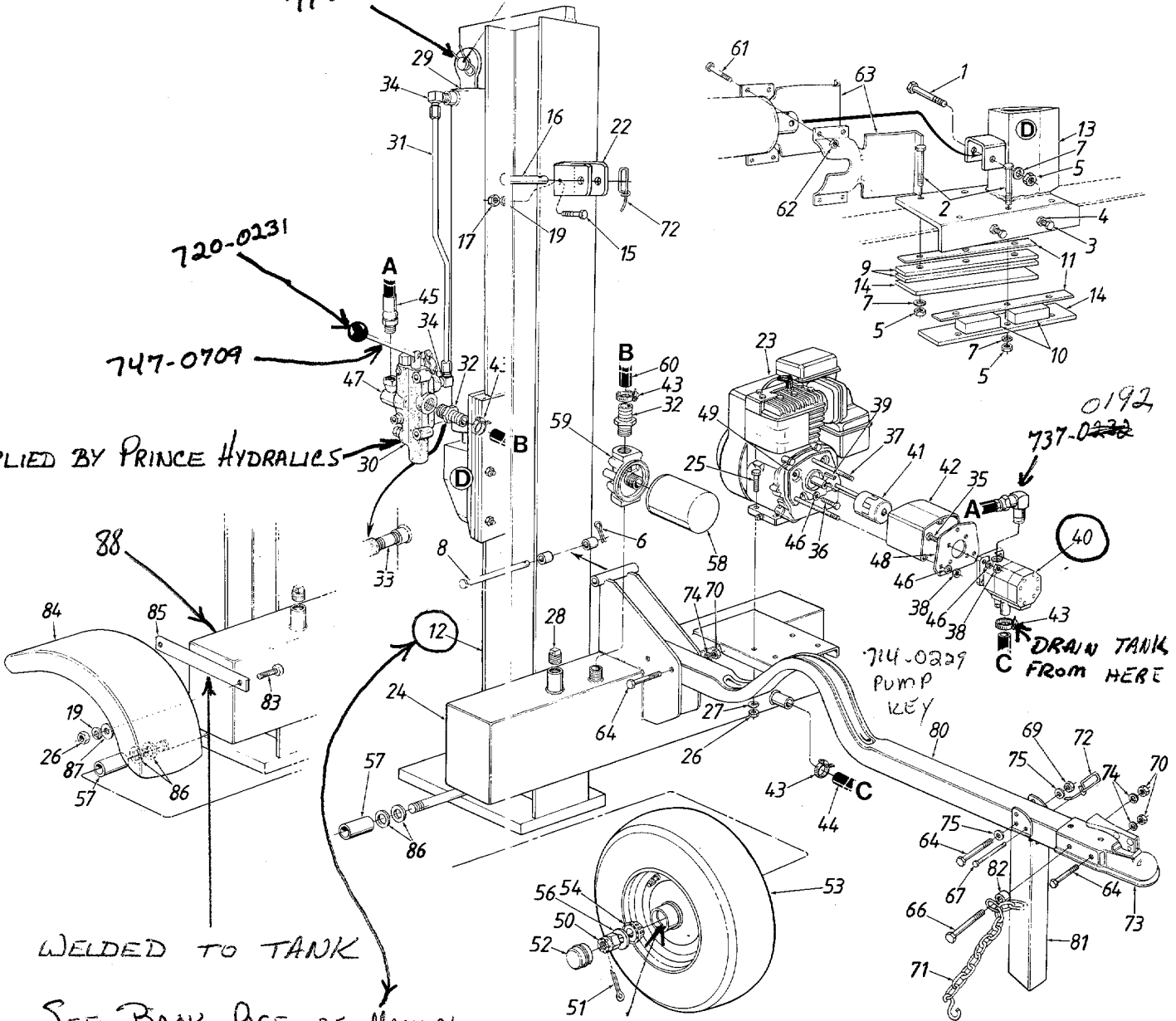

NOTE: The engine is not under warranty by the log splitter manufacturer . . . If repairs or service is needed on the engine, please contact your nearest authorized engine service outlet. Check the "Yellow pages" of your telephone book under "Engines - Gasoline".

Find It Fast
 In The
 Yellow Pages.

NOTE

Specifications subject to change without notice or obligation.

PRO/20 (Model 622)
PRO/22 (Model 623)

PARTS LIST FOR MODELS 622 and 623 LOG SPLITTERS

EF. NO.	PART NO.	COLOR CODE	DESCRIPTION	NEW PART	REF. NO.	PART NO.	COLOR CODE	DESCRIPTION	NEW PART
1	710-1010		Hex Bolt 1/2-20 x 3" Lg. (Grade 8)	N	43	726-0146		Adjustable Hose Clamp	
					44	727-0308		Suction Hose -20"	N
2	710-1018		Hex Bolt 1/2-20 x 2.75" Lg. (Grade 8)	N	45	727-0310		Pressure Hose	N
					46	736-0119		L-Wash. 5/16" I.D.*	
3	710-3029		Hex Bolt 7/16-20 x 1.25" Lg.	N	47	737-0234		90° Swivel	N
					48	781-0097		Rear Coupling Support Brkt.	
4	712-0240		Hex Jam Nut 7/16-20 Thd.					Front Coupling Support Brkt.	
5	712-0333		Hex Nut 1/2-20 Thd. (Grade 8)	N	49	781-0098		Hex Slotted Nut 3/4-16 Thd.	
6	714-0470		Cotter Pin 1/8 Dia.		50	712-0299		Cotter Pin 5/32" Dia.	
7	736-0921		L-Wash. 1/2" I.D.*	N	51	714-0162		Hub Cap	
8	738-0736		Hinge Pin 1/2" Dia.	N	52	734-0873		Wheel Ass'y. Comp.	
9	781-0127		Fixed Side Gib	N	53	734-1016		Tire Only	
10	781-0129		Adjustable Gib	N		734-0872		Rim Only	
11	781-0130		Adjustable Gib Shim	N		734-1017		Air Valve	
12	781-0132		Beam Ass'y. <i>USE 781-0131</i>	N		734-0255		Roller Bearing 2 PER WHEEL	
13	781-0140		Wedge Ass'y.	N	54	741-0107		Fl-Wash. .76" I.D. x 1.5" O.D.	
14	781-0142		Wedge Back Plate	N	56	736-0351		Spacer 1.56" Lg.	
15	710-0672		Hex Bolt 5/16-24 x 1.25" Lg.*		57	750-0442		Filter Element	N
16	711-3104		Clevis Pin		58	723-0405		Filter Head	N
17	712-3057		Hex Nut 5/16-24 Thd. (Grade 5)		59	723-0406		Return Hose — 30"	N
19	736-0119		L-Wash. 5/16" I.D.*		60	727-0309		Hex Bolt 3/8-16 x 2" Lg. (Grade 5)	
2	781-0273		Pivot Latch Brkt.	N	61	710-3144		Hex L-Nut 3/8-16 Thd.	
23	-----		Engine		62	712-0430		Stripper Half	N
24	781-0148		Tank Ass'y. Complete	N	63	781-0168		Hex Bolt 3/8-16x 3" Lg. (Grade 8)	
25	710-0409		Hex Bolt 5/16-24 x 1.75" Lg.*		64	710-0521		Hex Bolt 3/8-16 x 3.25" Lg. (Grade 8)	
26	712-0123		Hex Nut 5/16-24 Thd.*		66	710-3130		Clevis Pin 5/16" Dia.	N
27	736-0119		L-Wash. 5/16" I.D.*	N	67	711-0813		Hex L-Nut 3/8-16 Thd.	N
28	737-0236		Vent Plug	N	69	712-0375		Hex Nut 3/8-16 Thd.*	
29	717-0885		Hydraulic Cylinder**	N	70	712-0798		Tow Hitch Chain	
30	717-0886		Control Valve-	N	71	713-0338		Spring Pin	
31	727-0307		Metal Pressure Tube	N	72	732-0194		Hitch Coupler	
32	737-0235		3/4" Hose Barb	N	73	727-0311		L-Wash. 3/8" I.D.*	
33	737-0238		Pipe Nipple	N	74	736-0169		Fl-Wash. .406" I.D. x .75" O.D.	
34	737-0192		Elbow		75	736-0185		Tongue 753-0502	N
35	710-0117		Hex Bolt 5/16-24 x 1.0" Lg.*		80	781-0160		Jack Stand	N
36	710-0237		Hex Bolt 5/16-24 x .62" Lg.*		81	781-0162		Spacer 3/8" I.D. x .27" Lg.	
37	710-0363		Hex Bolt 5/16-24 x 4" Lg. (622)		82	750-0507		Hex Bolt 5/16-24 x 3/4" Lg. (Grade 5) †	
	710-0968		Hex Bolt 5/16-24 x 5" Lg. (623)		83	710-0157		Fender †	N
38	712-0123		Hex Nut 5/16-24 Thd.*		84	781-0271		Fender Support †	N
39	714-0122		Sq. Key 3/16" x .75"		85	781-0272		Fl-Wash. .78" I.D. x 2.0" O.D.	N
40	717-0887		Pump <i>SEE SUPL. WHEN ORDERING</i>		86	736-3014		Fl-Wash. .344" I.D. x .88" O.D.	N
41	717-0891		Flexible Coupling	N					
42	719-0278		Coupling Shield (622)		87	736-0159			
	719-0281		Coupling Shield (623)						

For faster service order standard nuts, bolts, and washers locally. If these items cannot be obtained locally, order by part number and size as shown on parts list.

**Hydraulic cylinder "O" ring kit available - order part number 753-0458.

† PRO/22 (Model 623) Only. ←

88 781-0270 OIL TANK ASSY †

3 YEAR WARRANTY

NON-COMMERCIAL

Limited to Models PRO/20 and 424/LCD/20 Log Splitters

For three years from the date of original retail purchase, DUERR INC will either repair or replace, at its option, free of charge, F.O.B. factory or authorized service firm, any part or parts found to be defective in material or workmanship. Transportation charges for the movement of any power equipment unit or attachment are the responsibility of the purchaser. Transportation charges for any parts submitted for replacement unit or attachment are the responsibility of the purchaser unless such return is requested by the purchaser.

	PART NUMBER	QUAN.
	712-0798	4
	736-0169	4
	710-0520	4
THESE PARTS ARE PART OF	714-0470	1
781-0131 BEAM ASSY.	738-0736	1
THE ORIGINAL SPACERS ARE NO LONGER	781-0373	1
WELDED ON THE BEAM (FOR HINGE).	781-0375	1
THESE PARTS ARE ALSO USED ON	781-0377	1
249-623		

DENNIS DUERR
PRESIDENT

'We stand behind our products'

DUERR INC. • MEAD, WASHINGTON 99021
(509) 238-6124