



OM-1500-14

207 499H

2007-07

Processes



- MIG (GMAW) Welding
- Flux Cored (FCAW) Welding (Gas and Self-Shielding)
- Submerged (SAW) Welding

Description



Wire Feeder
(Use with CV Power Sources)

DS-74DX Swingarc™

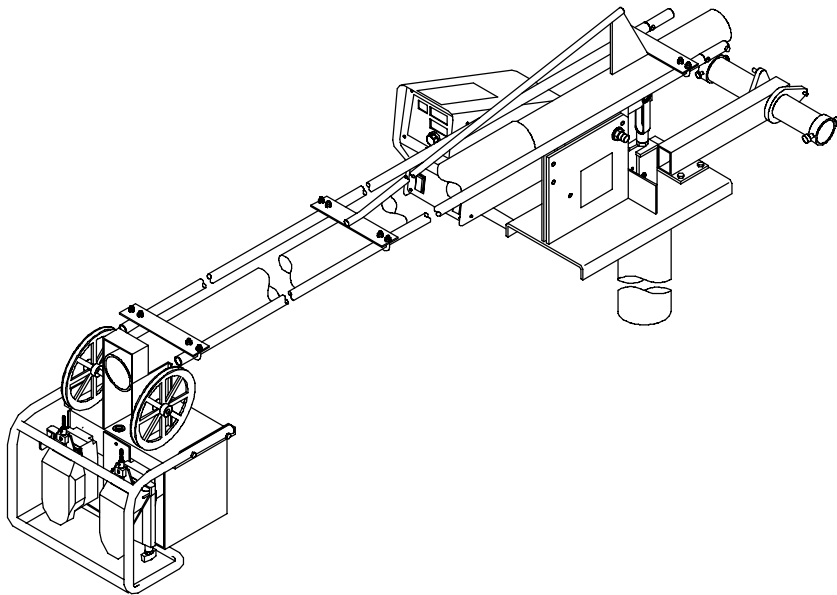

DS-74DX12, and DS-74DX16

OWNER'S MANUAL



Visit our website at
www.MillerWelds.com

File: MIG (GMAW)



From Miller to You

Thank you and congratulations on choosing Miller. Now you can get the job done and get it done right. We know you don't have time to do it any other way.

That's why when Niels Miller first started building arc welders in 1929, he made sure his products offered long-lasting value and superior quality. Like you, his customers couldn't afford anything less. Miller products had to be more than the best they could be. They had to be the best you could buy.

Today, the people that build and sell Miller products continue the tradition. They're just as committed to providing equipment and service that meets the high standards of quality and value established in 1929.

This Owner's Manual is designed to help you get the most out of your Miller products. Please take time to read the Safety precautions. They will help you protect yourself against potential hazards on the worksite.

We've made installation and operation quick and easy. With Miller you can count on years of reliable service with proper maintenance. And if for some reason the unit needs repair, there's a Troubleshooting section that will help you figure out what the problem is. The parts list will then help you to decide the exact part you may need to fix the problem. Warranty and service information for your particular model are also provided.



Miller is the first welding equipment manufacturer in the U.S.A. to be registered to the ISO 9001:2000 Quality System Standard.

Miller Electric manufactures a full line of welders and welding related equipment. For information on other quality Miller products, contact your local Miller distributor to receive the latest full line catalog or individual specification sheets. **To locate your nearest distributor or service agency call 1-800-4-A-Miller, or visit us at www.MillerWelds.com on the web.**



Working as hard as you do – every power source from Miller is backed by the most hassle-free warranty in the business.



TABLE OF CONTENTS

SECTION 1 – SAFETY PRECAUTIONS - READ BEFORE USING	1
1-1. Symbol Usage	1
1-2. Arc Welding Hazards	1
1-3. Additional Symbols For Installation, Operation, And Maintenance	3
1-4. California Proposition 65 Warnings	4
1-5. Principal Safety Standards	4
1-6. EMF Information	4
SECTION 2 – CONSIGNES DE SÉCURITÉ – LIRE AVANT UTILISATION	5
2-1. Symboles utilisés	5
2-2. Dangers relatifs au soudage à l'arc	5
2-3. Dangers supplémentaires en relation avec l'installation, le fonctionnement et la maintenance	7
2-4. Proposition californienne 65 Avertissements	8
2-5. Principales normes de sécurité	9
2-6. Information EMF	9
SECTION 3 – INTRODUCTION	11
3-1. Specifications	11
SECTION 4 – INSTALLATION	11
4-1. Installing Swivel Into Pipe Post	11
4-2. Installing Control Box And Adjusting Tilt	12
4-3. Installing Boom And Reel Support	12
4-4. Installing Wire Guide Extension	13
4-5. Equipment Connection Diagram	14
4-6. Control Box Connections	15
4-7. 14-Pin Plug Information	15
4-8. Removing Safety Collar And Adjusting Boom	16
4-9. Gun Recommendation Table	16
4-10. Wire Type, Size, And Feed Speed Capability Table	16
4-11. Installing And Threading Welding Wire	17
4-12. Setting Internal DIP Switches	18
4-13. Power Source Selection Menu	19
SECTION 5 – OPERATION	20
5-1. Operational Terms	20
5-2. Power Switch	20
5-3. Left/Right Select Switch	20
5-4. Jog/Purge Switch	21
5-5. Front Panel Controls	21
5-6. Program Push Button	22
5-7. Upper Display	22
5-8. Lower Display	23
5-9. Setup Push Button	23
5-10. Adjust Control	24
5-11. Sequence Push Button	24
5-12. Auxiliary Menus	25
SECTION 6 – SETTING SEQUENCE PARAMETERS	27
6-1. Sequence Parameters In A Program	27
SECTION 7 – SETTING DUAL SCHEDULE PARAMETERS	28
7-1. Optional Dual Schedule Switch Diagrams	28
7-2. Diagnostics	29
7-3. Diagnostics For User Defined Options	30
SECTION 8 – MAINTENANCE & TROUBLESHOOTING	30
8-1. Routine Maintenance	30
8-2. Troubleshooting	31

TABLE OF CONTENTS

SECTION 9 – ELECTRICAL DIAGRAM	32
SECTION 10 – PARTS LIST	34
OPTIONS AND ACCESSORIES	
WARRANTY	

SECTION 1 – SAFETY PRECAUTIONS - READ BEFORE USING

som_2007-04

 Protect yourself and others from injury — read and follow these precautions.

1-1. Symbol Usage

 **DANGER!** – Indicates a hazardous situation which, if not avoided, will result in death or serious injury. The possible hazards are shown in the adjoining symbols or explained in the text.

 Indicates a hazardous situation which, if not avoided, could result in death or serious injury. The possible hazards are shown in the adjoining symbols or explained in the text.

NOTICE – Indicates statements not related to personal injury.

 Indicates special instructions.



This group of symbols means Warning! Watch Out! ELECTRIC SHOCK, MOVING PARTS, and HOT PARTS hazards. Consult symbols and related instructions below for necessary actions to avoid the hazards.

1-2. Arc Welding Hazards

 The symbols shown below are used throughout this manual to call attention to and identify possible hazards. When you see the symbol, watch out, and follow the related instructions to avoid the hazard. The safety information given below is only a summary of the more complete safety information found in the Safety Standards listed in Section 1-5. Read and follow all Safety Standards.

 Only qualified persons should install, operate, maintain, and repair this unit.

 During operation, keep everybody, especially children, away.



ELECTRIC SHOCK can kill.

Touching live electrical parts can cause fatal shocks or severe burns. The electrode and work circuit is electrically live whenever the output is on. The input power circuit and machine internal circuits are also live when power is on. In semiautomatic or automatic wire welding, the wire, wire reel, drive roll housing, and all metal parts touching the welding wire are electrically live. Incorrectly installed or improperly grounded equipment is a hazard.

- Do not touch live electrical parts.
- Wear dry, hole-free insulating gloves and body protection.
- Insulate yourself from work and ground using dry insulating mats or covers big enough to prevent any physical contact with the work or ground.
- Do not use AC output in damp areas, if movement is confined, or if there is a danger of falling.
- Use AC output ONLY if required for the welding process.
- If AC output is required, use remote output control if present on unit.
- Additional safety precautions are required when any of the following electrically hazardous conditions are present: in damp locations or while wearing wet clothing; on metal structures such as floors, gratings, or scaffolds; when in cramped positions such as sitting, kneeling, or lying; or when there is a high risk of unavoidable or accidental contact with the workpiece or ground. For these conditions, use the following equipment in order presented: 1) a semiautomatic DC constant voltage (wire) welder, 2) a DC manual (stick) welder, or 3) an AC welder with reduced open-circuit voltage. In most situations, use of a DC, constant voltage wire welder is recommended. And, do not work alone!
- Disconnect input power or stop engine before installing or servicing this equipment. Lockout/tagout input power according to OSHA 29 CFR 1910.147 (see Safety Standards).
- Properly install and ground this equipment according to its Owner's Manual and national, state, and local codes.

- Always verify the supply ground – check and be sure that input power cord ground wire is properly connected to ground terminal in disconnect box or that cord plug is connected to a properly grounded receptacle outlet.
- When making input connections, attach proper grounding conductor first – double-check connections.
- Keep cords dry, free of oil and grease, and protected from hot metal and sparks.
- Frequently inspect input power cord for damage or bare wiring – replace cord immediately if damaged – bare wiring can kill.
- Turn off all equipment when not in use.
- Do not use worn, damaged, undersized, or poorly spliced cables.
- Do not drape cables over your body.
- If earth grounding of the workpiece is required, ground it directly with a separate cable.
- Do not touch electrode if you are in contact with the work, ground, or another electrode from a different machine.
- Do not touch electrode holders connected to two welding machines at the same time since double open-circuit voltage will be present.
- Use only well-maintained equipment. Repair or replace damaged parts at once. Maintain unit according to manual.
- Wear a safety harness if working above floor level.
- Keep all panels and covers securely in place.
- Clamp work cable with good metal-to-metal contact to workpiece or worktable as near the weld as practical.
- Insulate work clamp when not connected to workpiece to prevent contact with any metal object.
- Do not connect more than one electrode or work cable to any single weld output terminal.

SIGNIFICANT DC VOLTAGE exists in inverter-type welding power sources after removal of input power.

- Turn Off inverter, disconnect input power, and discharge input capacitors according to instructions in Maintenance Section before touching any parts.



HOT PARTS can cause severe burns.

- Do not touch hot parts bare handed.
- Allow cooling period before working on gun or torch.
- To handle hot parts, use proper tools and/or wear heavy, insulated welding gloves and clothing to prevent burns.



FUMES AND GASES can be hazardous.

Welding produces fumes and gases. Breathing these fumes and gases can be hazardous to your health.

- Keep your head out of the fumes. Do not breathe the fumes.
- If inside, ventilate the area and/or use local forced ventilation at the arc to remove welding fumes and gases.
- If ventilation is poor, wear an approved air-supplied respirator.
- Read and understand the Material Safety Data Sheets (MSDSs) and the manufacturer's instructions for metals, consumables, coatings, cleaners, and degreasers.
- Work in a confined space only if it is well ventilated, or while wearing an air-supplied respirator. Always have a trained watchperson nearby. Welding fumes and gases can displace air and lower the oxygen level causing injury or death. Be sure the breathing air is safe.
- Do not weld in locations near degreasing, cleaning, or spraying operations. The heat and rays of the arc can react with vapors to form highly toxic and irritating gases.
- Do not weld on coated metals, such as galvanized, lead, or cadmium plated steel, unless the coating is removed from the weld area, the area is well ventilated, and while wearing an air-supplied respirator. The coatings and any metals containing these elements can give off toxic fumes if welded.



ARC RAYS can burn eyes and skin.

Arc rays from the welding process produce intense visible and invisible (ultraviolet and infrared) rays that can burn eyes and skin. Sparks fly off from the weld.

- Wear an approved welding helmet fitted with a proper shade of filter lenses to protect your face and eyes when welding or watching (see ANSI Z49.1 and Z87.1 listed in Safety Standards).
- Wear approved safety glasses with side shields under your helmet.
- Use protective screens or barriers to protect others from flash, glare and sparks; warn others not to watch the arc.
- Wear protective clothing made from durable, flame-resistant material (leather, heavy cotton, or wool) and foot protection.



WELDING can cause fire or explosion.

Welding on closed containers, such as tanks, drums, or pipes, can cause them to blow up. Sparks can fly off from the welding arc. The flying sparks, hot workpiece, and hot equipment can cause fires and explosions. Accidental contact of electrode to metal objects can cause sparks, explosion, overheating, or fire. Check and be sure the area is safe before doing any welding.

- Remove all flammables within 35 ft (10.7 m) of the welding arc. If this is not possible, tightly cover them with approved covers.
- Do not weld where flying sparks can strike flammable material.
- Protect yourself and others from flying sparks and hot metal.
- Be alert that welding sparks and hot materials from welding can easily go through small cracks and openings to adjacent areas.
- Watch for fire, and keep a fire extinguisher nearby.
- Be aware that welding on a ceiling, floor, bulkhead, or partition can cause fire on the hidden side.
- Do not weld on closed containers such as tanks, drums, or pipes, unless they are properly prepared according to AWS F4.1 (see Safety Standards).
- Do not weld where the atmosphere may contain flammable dust, gas, or liquid vapors (such as gasoline).
- Connect work cable to the work as close to the welding area as practical to prevent welding current from traveling long, possibly unknown paths and causing electric shock, sparks, and fire hazards.

- Do not use welder to thaw frozen pipes.
- Remove stick electrode from holder or cut off welding wire at contact tip when not in use.
- Wear oil-free protective garments such as leather gloves, heavy shirt, cuffless trousers, high shoes, and a cap.
- Remove any combustibles, such as a butane lighter or matches, from your person before doing any welding.
- After completion of work, inspect area to ensure it is free of sparks, glowing embers, and flames.
- Use only correct fuses or circuit breakers. Do not oversize or bypass them.
- Follow requirements in OSHA 1910.252 (a) (2) (iv) and NFPA 51B for hot work and have a fire watcher and extinguisher nearby.

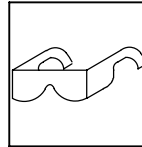

FLYING METAL or DIRT can injure eyes.

- Welding, chipping, wire brushing, and grinding cause sparks and flying metal. As welds cool, they can throw off slag.
- Wear approved safety glasses with side shields even under your welding helmet.



BUILDUP OF GAS can injure or kill.

- Shut off shielding gas supply when not in use.
- Always ventilate confined spaces or use approved air-supplied respirator.

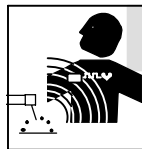

MAGNETIC FIELDS can affect Implanted Medical Devices.

- Wearers of Pacemakers and other Implanted Medical Devices should keep away.
- Implanted Medical Device wearers should consult their doctor and the device manufacturer before going near arc welding, spot welding, gouging, plasma arc cutting, or induction heating operations.

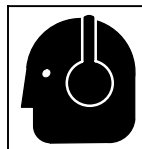

NOISE can damage hearing.

Noise from some processes or equipment can damage hearing.

- Wear approved ear protection if noise level is high.

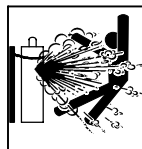

CYLINDERS can explode if damaged.

Shielding gas cylinders contain gas under high pressure. If damaged, a cylinder can explode. Since gas cylinders are normally part of the welding process, be sure to treat them carefully.

- Protect compressed gas cylinders from excessive heat, mechanical shocks, physical damage, slag, open flames, sparks, and arcs.
- Install cylinders in an upright position by securing to a stationary support or cylinder rack to prevent falling or tipping.
- Keep cylinders away from any welding or other electrical circuits.
- Never drape a welding torch over a gas cylinder.
- Never allow a welding electrode to touch any cylinder.
- Never weld on a pressurized cylinder – explosion will result.
- Use only correct shielding gas cylinders, regulators, hoses, and fittings designed for the specific application; maintain them and associated parts in good condition.
- Turn face away from valve outlet when opening cylinder valve.
- Keep protective cap in place over valve except when cylinder is in use or connected for use.
- Use the right equipment, correct procedures, and sufficient number of persons to lift and move cylinders.
- Read and follow instructions on compressed gas cylinders, associated equipment, and Compressed Gas Association (CGA) publication P-1 listed in Safety Standards.

1-3. Additional Symbols For Installation, Operation, And Maintenance



FIRE OR EXPLOSION hazard.

- Do not install or place unit on, over, or near combustible surfaces.
- Do not install unit near flammables.
- Do not overload building wiring – be sure power supply system is properly sized, rated, and protected to handle this unit.



FALLING UNIT can cause injury.

- Use lifting eye to lift unit only, NOT running gear, gas cylinders, or any other accessories.
- Use equipment of adequate capacity to lift and support unit.
- If using lift forks to move unit, be sure forks are long enough to extend beyond opposite side of unit.

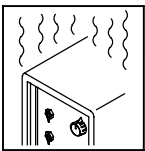

OVERUSE can cause OVERHEATING

- Allow cooling period; follow rated duty cycle.
- Reduce current or reduce duty cycle before starting to weld again.
- Do not block or filter airflow to unit.

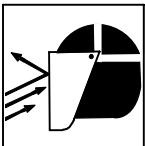

FLYING SPARKS can cause injury.

- Wear a face shield to protect eyes and face.
- Shape tungsten electrode only on grinder with proper guards in a safe location wearing proper face, hand, and body protection.
- Sparks can cause fires — keep flammables away.

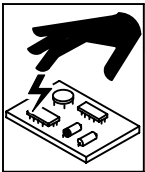

STATIC (ESD) can damage PC boards.

- Put on grounded wrist strap BEFORE handling boards or parts.
- Use proper static-proof bags and boxes to store, move, or ship PC boards.



MOVING PARTS can cause injury.

- Keep away from moving parts.
- Keep away from pinch points such as drive rolls.



WELDING WIRE can cause injury.

- Do not press gun trigger until instructed to do so.
- Do not point gun toward any part of the body, other people, or any metal when threading welding wire.



MOVING PARTS can cause injury.

- Keep away from moving parts such as fans.
- Keep all doors, panels, covers, and guards closed and securely in place.
- Have only qualified persons remove doors, panels, covers, or guards for maintenance as necessary.
- Reinstall doors, panels, covers, or guards when maintenance is finished and before reconnecting input power.

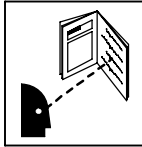

READ INSTRUCTIONS.

- Read Owner's Manual before using or servicing unit.
- Use only genuine replacement parts from the manufacturer.

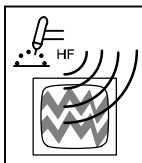

H.F. RADIATION can cause interference.

- High-frequency (H.F.) can interfere with radio navigation, safety services, computers, and communications equipment.
- Have only qualified persons familiar with electronic equipment perform this installation.
- The user is responsible for having a qualified electrician promptly correct any interference problem resulting from the installation.
- If notified by the FCC about interference, stop using the equipment at once.
- Have the installation regularly checked and maintained.
- Keep high-frequency source doors and panels tightly shut, keep spark gaps at correct setting, and use grounding and shielding to minimize the possibility of interference.

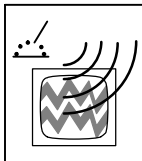

ARC WELDING can cause interference.

- Electromagnetic energy can interfere with sensitive electronic equipment such as computers and computer-driven equipment such as robots.
- Be sure all equipment in the welding area is electromagnetically compatible.
- To reduce possible interference, keep weld cables as short as possible, close together, and down low, such as on the floor.
- Locate welding operation 100 meters from any sensitive electronic equipment.
- Be sure this welding machine is installed and grounded according to this manual.
- If interference still occurs, the user must take extra measures such as moving the welding machine, using shielded cables, using line filters, or shielding the work area.

1-4. California Proposition 65 Warnings

 Welding or cutting equipment produces fumes or gases which contain chemicals known to the State of California to cause birth defects and, in some cases, cancer. (California Health & Safety Code Section 25249.5 et seq.)

 Battery posts, terminals and related accessories contain lead and lead compounds, chemicals known to the State of California to cause cancer and birth defects or other reproductive harm. Wash hands after handling.

For Gasoline Engines:

 Engine exhaust contains chemicals known to the State of California to cause cancer, birth defects, or other reproductive harm.

For Diesel Engines:

 Diesel engine exhaust and some of its constituents are known to the State of California to cause cancer, birth defects, and other reproductive harm.

1-5. Principal Safety Standards

Safety in Welding, Cutting, and Allied Processes, ANSI Standard Z49.1, from Global Engineering Documents (phone: 1-877-413-5184, website: www.global.ihs.com).

Recommended Safe Practices for the Preparation for Welding and Cutting of Containers and Piping, American Welding Society Standard AWS F4.1, from Global Engineering Documents (phone: 1-877-413-5184, website: www.global.ihs.com).

National Electrical Code, NFPA Standard 70, from National Fire Protection Association, P.O. Box 9101, Quincy, MA 02269-9101 (phone: 617-770-3000, website: www.nfpa.org and www.sparky.org).

Safe Handling of Compressed Gases in Cylinders, CGA Pamphlet P-1, from Compressed Gas Association, 4221 Walney Road, 5th Floor, Chantilly, VA 20151 (phone: 703-788-2700, website: www.cganet.com).

Code for Safety in Welding and Cutting, CSA Standard W117.2, from Canadian Standards Association, Standards Sales, 5060 Mississauga,

Ontario, Canada L4W 5NS (phone: 800-463-6727 or in Toronto 416-747-4044, website: www.csa-international.org).

Safe Practice For Occupational And Educational Eye And Face Protection, ANSI Standard Z87.1, from American National Standards Institute, 25 West 43rd Street, New York, NY 10036-8002 (phone: 212-642-4900, website: www.ansi.org).

Standard for Fire Prevention During Welding, Cutting, and Other Hot Work, NFPA Standard 51B, from National Fire Protection Association, P.O. Box 9101, Quincy, MA 02269-9101 (phone: 617-770-3000, website: www.nfpa.org).

OSHA, Occupational Safety and Health Standards for General Industry, Title 29, Code of Federal Regulations (CFR), Part 1910, Subpart Q, and Part 1926, Subpart J, from U.S. Government Printing Office, Superintendent of Documents, P.O. Box 371954, Pittsburgh, PA 15250-7954 (phone: 1-866-512-1800) (there are 10 Regional Offices—phone for Region 5, Chicago, is 312-353-2220, website: www.osha.gov).

1-6. EMF Information

Considerations About Welding And The Effects Of Low Frequency Electric And Magnetic Fields

Welding current, as it flows through welding cables, will cause electromagnetic fields. There has been and still is some concern about such fields. However, after examining more than 500 studies spanning 17 years of research, a special blue ribbon committee of the National Research Council concluded that: "The body of evidence, in the committee's judgment, has not demonstrated that exposure to power-frequency electric and magnetic fields is a human-health hazard." However, studies are still going forth and evidence continues to be examined. Until the final conclusions of the research are reached, you may wish to minimize your exposure to electromagnetic fields when welding or cutting.

To reduce magnetic fields in the workplace, use the following procedures:

1. Keep cables close together by twisting or taping them, or using a cable cover.
2. Arrange cables to one side and away from the operator.
3. Do not coil or drape cables around your body.
4. Keep welding power source and cables as far away from operator as practical.
5. Connect work clamp to workpiece as close to the weld as possible.

About Implanted Medical Devices:

Implanted Medical Device wearers should consult their doctor and the device manufacturer before performing or going near arc welding, spot welding, gouging, plasma arc cutting, or induction heating operations. If cleared by your doctor, then following the above procedures is recommended.

SECTION 2 – CONSIGNES DE SÉCURITÉ – LIRE AVANT UTILISATION

fre_som_2007-04

! Se protéger et protéger les autres contre le risque de blessure — lire et respecter ces consignes.

2-1. Symboles utilisés



DANGER! – Indique une situation dangereuse qui si on l'évite pas peut donner la mort ou des blessures graves. Les dangers possibles sont montrés par les symboles joints ou sont expliqués dans le texte.



Indique une situation dangereuse qui si on l'évite pas peut donner la mort ou des blessures graves. Les dangers possibles sont montrés par les symboles joints ou sont expliqués dans le texte.

NOTE – Indique des déclarations pas en relation avec des blessures personnelles.

 Indique des instructions spécifiques.



Ce groupe de symboles veut dire Avertissement! Attention! DANGER DE CHOC ELECTRIQUE, PIECES EN MOUVEMENT, et PIECES CHAUDES. Consulter les symboles et les instructions ci-dessous y afférant pour les actions nécessaires afin d'éviter le danger.

2-2. Dangers relatifs au soudage à l'arc



Les symboles représentés ci-dessous sont utilisés dans ce manuel pour attirer l'attention et identifier les dangers possibles. En présence de l'un de ces symboles, prendre garde et suivre les instructions afférentes pour éviter tout risque. Les instructions en matière de sécurité indiquées ci-dessous ne constituent qu'un sommaire des instructions de sécurité plus complètes fournies dans les normes de sécurité énumérées dans la Section 2-5. Lire et observer toutes les normes de sécurité.



Seul un personnel qualifié est autorisé à installer, faire fonctionner, entretenir et réparer cet appareil.



Pendant le fonctionnement, maintenir à distance toutes les personnes, notamment les enfants de l'appareil.



UNE DÉCHARGE ÉLECTRIQUE peut entraîner la mort.

Le contact d'organes électriques sous tension peut provoquer des accidents mortels ou des brûlures graves. Le circuit de l'électrode et de la pièce est sous tension lorsque le courant est délivré à la sortie. Le circuit d'alimentation et les circuits internes de la machine sont également sous tension lorsque l'alimentation est sur Marche. Dans le mode de soudage avec du fil, le fil, le dérouleur, le bloc de commande du rouleau et toutes les parties métalliques en contact avec le fil sont sous tension électrique. Un équipement installé ou mis à la terre de manière incorrecte ou impropre constitue un danger.

- Ne pas toucher aux pièces électriques sous tension.
- Porter des gants isolants et des vêtements de protection secs et sans trous.
- S'isoler de la pièce à couper et du sol en utilisant des housses ou des tapis assez grands afin d'éviter tout contact physique avec la pièce à couper ou le sol.
- Ne pas se servir de source électrique à courant électrique dans les zones humides, dans les endroits confinés ou là où on risque de tomber.
- Se servir d'une source électrique à courant électrique UNIQUEMENT si le procédé de soudage le demande.
- Si l'utilisation d'une source électrique à courant électrique s'avère nécessaire, se servir de la fonction de télécommande si l'appareil en est équipé.
- D'autres consignes de sécurité sont nécessaires dans les conditions suivantes : risques électriques dans un environnement humide ou si l'on porte des vêtements mouillés ; sur des structures métalliques telles que sols, grilles ou échafaudages ; en position coincée comme assise, à genoux ou couchée ; ou s'il y a un risque élevé de contact inévitable ou accidentel avec la pièce à souder ou le sol. Dans ces conditions, utiliser les équipements suivants, dans l'ordre indiqué : 1) un poste à souder DC à tension constante (à fil), 2) un poste à souder DC manuel (électrode) ou 3) un poste à souder AC à tension à vide réduite. Dans la plupart des situations, l'utilisation d'un poste à souder DC à fil à tension constante est recommandée. En outre, ne pas travailler seul !
- Couper l'alimentation ou arrêter le moteur avant de procéder à l'installation, à la réparation ou à l'entretien de l'appareil. Déverrouiller l'alimentation selon la norme OSHA 29 CFR 1910.147 (voir normes de sécurité).
- Installer le poste correctement et le mettre à la terre convenablement selon les consignes du manuel de l'opérateur et les normes nationales, provinciales et locales.
- Toujours vérifier la terre du cordon d'alimentation. Vérifier et s'assurer que le fil de terre du cordon d'alimentation est bien raccordé à la borne de terre du sectionneur ou que la fiche du cordon est raccordée à une prise correctement mise à la terre.
- En effectuant les raccordements d'entrée, fixer d'abord le conducteur de mise à la terre approprié et contre-vérifier les connexions.
- Les câbles doivent être exempts d'humidité, d'huile et de graisse; protégez-les contre les étincelles et les pièces métalliques chaudes.
- Vérifier fréquemment le cordon d'alimentation afin de s'assurer qu'il n'est pas altéré ou à nu, le remplacer immédiatement s'il l'est. Un fil à nu peut entraîner la mort.
- L'équipement doit être hors tension lorsqu'il n'est pas utilisé.
- Ne pas utiliser des câbles usés, endommagés, de grosseur insuffisante ou mal épissés.
- Ne pas enrouler les câbles autour du corps.
- Si la pièce soudée doit être mise à la terre, le faire directement avec un câble distinct.
- Ne pas toucher l'électrode quand on est en contact avec la pièce, la terre ou une électrode provenant d'une autre machine.
- Ne pas toucher des porte électrodes connectés à deux machines en même temps à cause de la présence d'une tension à vide doublée.
- N'utiliser qu'un matériel en bon état. Réparer ou remplacer sur-le-champ les pièces endommagées. Entretenir l'appareil conformément à ce manuel.
- Porter un harnais de sécurité si l'on doit travailler au-dessus du sol.
- S'assurer que tous les panneaux et couvercles sont correctement en place.
- Fixer le câble de retour de façon à obtenir un bon contact métal-métal avec la pièce à souder ou la table de travail, le plus près possible de la soudure.
- Isoler la pince de masse quand pas mis à la pièce pour éviter le contact avec tout objet métallique.
- Ne pas raccorder plus d'une électrode ou plus d'un câble de masse à une même borne de sortie de soudage.

Il reste une TENSION DC NON NÉGLIGEABLE dans les sources de soudage onduleur quand on a coupé l'alimentation.

- Arrêter les convertisseurs, débrancher le courant électrique et décharger les condensateurs d'alimentation selon les instructions indiquées dans la partie Entretien avant de toucher les pièces.



DES PIÈCES CHAUDES peuvent provoquer des brûlures graves.

- Ne pas toucher à mains nues les parties chaudes.
- Prévoir une période de refroidissement avant de travailler à l'équipement.
- Ne pas toucher aux pièces chaudes, utiliser les outils recommandés et porter des gants de soudage et des vêtements épais pour éviter les brûlures.



LES FUMÉES ET LES GAZ peuvent être dangereux.

Le soudage génère des fumées et des gaz. Leur inhalation peut être dangereux pour votre santé.

- Eloigner votre tête des fumées. Ne pas respirer les fumées.
- À l'intérieur, ventiler la zone et/ou utiliser une ventilation forcée au niveau de l'arc pour l'évacuation des fumées et des gaz de soudage.
- Si la ventilation est médiocre, porter un respirateur anti-vapeurs approuvé.
- Lire et comprendre les spécifications de sécurité des matériaux (MSDS) et les instructions du fabricant concernant les métaux, les consommables, les revêtements, les nettoyants et les dégraissants.
- Travailler dans un espace fermé seulement s'il est bien ventilé ou en portant un respirateur à alimentation d'air. Demander toujours à un surveillant dûment formé de se tenir à proximité. Des fumées et des gaz de soudage peuvent déplacer l'air et abaisser le niveau d'oxygène provoquant des blessures ou des accidents mortels. S'assurer que l'air de respiration ne présente aucun danger.
- Ne pas souder dans des endroits situés à proximité d'opérations de dégraissage, de nettoyage ou de pulvérisation. La chaleur et les rayons de l'arc peuvent réagir en présence de vapeurs et former des gaz hautement toxiques et irritants.
- Ne pas souder des métaux munis d'un revêtement, tels que l'acier galvanisé, plaqué en plomb ou au cadmium à moins que le revêtement n'ait été enlevé dans la zone de soudure, que l'endroit soit bien ventilé, et en portant un respirateur à alimentation d'air. Les revêtements et tous les métaux renfermant ces éléments peuvent dégager des fumées toxiques en cas de soudage.

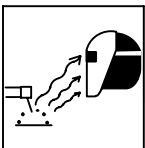

LES RAYONS DE L'ARC peuvent provoquer des brûlures dans les yeux et sur la peau.

Le rayonnement de l'arc du procédé de soudage génère des rayons visibles et invisibles intense (ultraviolets et infrarouges) susceptibles de provoquer des brûlures dans les yeux et sur la peau. Des étincelles sont projetées pendant le soudage.

- Porter un casque de soudage approuvé muni de verres filtrants approprié pour protéger visage et yeux pendant le soudage (voir ANSI Z49.1 et Z87.1 énuméré dans les normes de sécurité).
- Porter des lunettes de sécurité avec écrans latéraux même sous votre casque.
- Avoir recours à des écrans protecteurs ou à des rideaux pour protéger les autres contre les rayonnements les éblouissements et les étincelles ; prévenir toute personne sur les lieux de ne pas regarder l'arc.
- Porter des vêtements confectionnés avec des matières résistantes et ignifuges (cuir, coton lourd ou laine) et des bottes de protection.



LE SOUDAGE peut provoquer un incendie ou une explosion.

Le soudage effectué sur des conteneurs fermés tel que des réservoirs, tambours ou des conduites peut provoquer leur éclatement. Des étincelles peuvent être projetées de l'arc de soudure. La projection d'étincelles, des pièces chaudes et des équipements chauds peut provoquer des incendies et des brûlures. Le contact accidentel de l'électrode avec des objets métalliques peut provoquer des étincelles, une explosion, un surchauffement ou un incendie. Avant de commencer le soudage, vérifier et s'assurer que l'endroit ne présente pas de danger.

- Déplacer toutes les substances inflammables à une distance de 10,7 m de l'arc de soudage. En cas d'impossibilité les recouvrir soigneusement avec des protections homologués.
- Ne pas souder dans un endroit où des étincelles peuvent tomber sur des substances inflammables.
- Se protéger et d'autres personnes de la projection d'étincelles et de métal chaud.
- Des étincelles et des matériaux chauds du soudage peuvent facilement passer dans d'autres zones en traversant de petites fissures et des ouvertures.
- Surveiller tout déclenchement d'incendie et tenir un extincteur à proximité.
- Le soudage effectué sur un plafond, plancher, paroi ou séparation peut déclencher un incendie de l'autre côté.
- Ne pas effectuer le soudage sur des conteneurs fermés tels que des réservoirs, tambours, ou conduites, à moins qu'ils n'aient été préparés correctement conformément à AWS F4.1 (voir les normes de sécurité).
- Ne soudez pas si l'air ambiant est chargé de particules, gaz, ou vapeurs inflammables (vapeur d'essence, par exemple).
- Brancher le câble de masse sur la pièce la plus près possible de la zone de soudage pour éviter le transport du courant sur une longue distance par des chemins inconnus éventuels en provoquant des risques d'électrocution, d'étincelles et d'incendie.
- Ne pas utiliser le poste de soudage pour dégeler des conduites gelées.
- En cas de non utilisation, enlever la baguette d'électrode du porte-électrode ou couper le fil à la pointe de contact.
- Porter des vêtements de protection dépourvus d'huile tels que des gants en cuir, une chemise en matériau lourd, des pantalons sans revers, des chaussures hautes et un couvre chef.
- Avant de souder, retirer toute substance combustible de vos poches telles qu'un allumeur au butane ou des allumettes.
- Une fois le travail achevé, assurez-vous qu'il ne reste aucune trace d'étincelles incandescentes ni de flammes.
- Utiliser exclusivement des fusibles ou coupe-circuits appropriés. Ne pas augmenter leur puissance; ne pas les ponter.
- Une fois le travail achevé, assurez-vous qu'il ne reste aucune trace d'étincelles incandescentes ni de flammes.
- Utiliser exclusivement des fusibles ou coupe-circuits appropriés. Ne pas augmenter leur puissance; ne pas les ponter.
- Suivre les recommandations dans OSHA 1910.252(a)(2)(iv) et NFPA 51B pour les travaux à chaud et avoir de la surveillance et un extincteur à proximité.

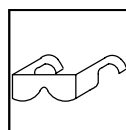

DES PIÈCES DE METAL ou DES SALETES peuvent provoquer des blessures dans les yeux.

- Le soudage, l'écaillage, le passage de la pièce à la brosse en fil de fer, et le meulage génèrent des étincelles et des particules métalliques volantes. Pendant la période de refroidissement des soudures, elles risquent de projeter du laitier.
- Porter des lunettes de sécurité avec écrans latéraux ou un écran facial.



LES ACCUMULATIONS DE GAZ risquent de provoquer des blessures ou même la mort.

- Fermer l'alimentation du gaz protecteur en cas de non-utilisation.
- Veiller toujours à bien aérer les espaces confinés ou se servir d'un respirateur d'adduction d'air homologué.



LES CHAMPS MAGNETIQUES peuvent affecter des implants médicaux.

- Porteur de simulateur cardiaque ou autre implants médicaux, rester à distance.
- Les porteurs d'implants doivent d'abord consulter leur médecin avant de s'approcher des opérations de soudage à l'arc, de soudage par points, de gougeage, du coupage plasma ou de chauffage par induction.



LE BRUIT peut endommager l'ouïe.

Le bruit des processus et des équipements peut affecter l'ouïe.

- Porter des protections approuvées pour les oreilles si le niveau sonore est trop élevé.

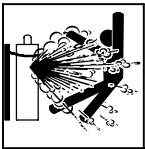

LES BOUTEILLES peuvent exploser si elles sont endommagées.

Des bouteilles de gaz protecteur contiennent du gaz sous haute pression. Si une bouteille est endommagée, elle peut exploser. Du fait que les bouteilles de gaz font normalement partie du procédé de soudage, les manipuler avec précaution.

- Protéger les bouteilles de gaz comprimé d'une chaleur excessive, des chocs mécaniques, des dommages physiques, du laitier, des flammes ouvertes, des étincelles et des arcs.
- Placer les bouteilles debout en les fixant dans un support stationnaire ou dans un porte-bouteilles pour les empêcher de tomber ou de se renverser.
- Tenir les bouteilles éloignées des circuits de soudage ou autres circuits électriques.
- Ne jamais placer une torche de soudage sur une bouteille à gaz.
- Une électrode de soudage ne doit jamais entrer en contact avec une bouteille.
- Ne jamais souder une bouteille pressurisée – risque d'explosion.
- Utiliser seulement des bouteilles de gaz protecteur, régulateurs, tuyaux et raccords convenables pour cette application spécifique ; les maintenir ainsi que les éléments associés en bon état.
- Détourner votre visage du détendeur-régulateur lorsque vous ouvrez la soupape de la bouteille.
- Le couvercle du détendeur doit toujours être en place, sauf lorsque la bouteille est utilisée ou qu'elle est reliée pour usage ultérieur.
- Utiliser les équipements corrects, les bonnes procédures et suffisamment de personnes pour soulever et déplacer les bouteilles.
- Lire et suivre les instructions sur les bouteilles de gaz comprimé, l'équipement connexe et le dépliant P-1 de la CGA (Compressed Gas Association) mentionné dans les principales normes de sécurité.

2-3. Dangers supplémentaires en relation avec l'installation, le fonctionnement et la maintenance



Risque D'INCENDIE OU D'EXPLOSION.

- Ne pas placer l'appareil sur, au-dessus ou à proximité de surfaces inflammables.
- Ne pas installer l'appareil à proximité de produits inflammables.
- Ne pas surcharger l'installation électrique – s'assurer que l'alimentation est correctement dimensionnée et protégée avant de mettre l'appareil en service.

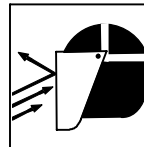

LES ÉTINCELLES VOLANTES risquent de provoquer des blessures.

- Porter un écran facial pour protéger le visage et les yeux.
- Affûter l'électrode au tungstène uniquement à la meuleuse dotée de protecteurs. Cette manœuvre est à exécuter dans un endroit sûr lorsque l'on porte l'équipement homologué de protection du visage, des mains et du corps.
- Les étincelles risquent de causer un incendie – éloigner toute substance inflammable.



LA CHUTE DE L'APPAREIL peut blesser.

- Utiliser l'anneau de levage uniquement pour soulever l'appareil, NON PAS les chariots, les bouteilles de gaz ou tout autre accessoire.
- Utiliser un équipement de levage de capacité suffisante pour lever l'appareil.
- En utilisant des fourches de levage pour déplacer l'unité, s'assurer que les fourches sont suffisamment longues pour dépasser du côté opposé de l'appareil.

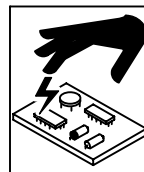

LES CHARGES ÉLECTROSTATIQUES peuvent endommager les circuits imprimés.

- Établir la connexion avec la barrette de terre avant de manipuler des cartes ou des pièces.
- Utiliser des pochettes et des boîtes antistatiques pour stocker, déplacer ou expédier des cartes de circuits imprimés.

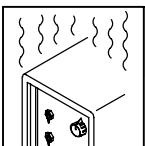

L'EMPLOI EXCESSIF peut SURCHAUFFER L'ÉQUIPEMENT.

- Prévoir une période de refroidissement ; respecter le cycle opératoire nominal.
- Réduire le courant ou le facteur de marche avant de poursuivre le soudage.
- Ne pas obstruer les passages d'air du poste.

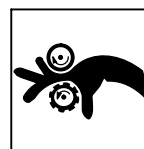

DES ORGANES MOBILES peuvent provoquer des blessures.

- Ne pas s'approcher des organes mobiles.
- Ne pas s'approcher des points de coincement tels que des rouleaux de commande.



LES FILS DE SOUDAGE peuvent provoquer des blessures.

- Ne pas appuyer sur la gâchette avant d'en avoir reçu l'instruction.
- Ne pas diriger le pistolet vers soi, d'autres personnes ou toute pièce mécanique en engageant le fil de soudage.



DES ORGANES MOBILES peuvent provoquer des blessures.

- S'abstenir de toucher des organes mobiles tels que des ventilateurs.
- Maintenir fermés et verrouillés les portes, panneaux, recouvrements et dispositifs de protection.
- Seules des personnes qualifiées sont autorisées à enlever les portes, panneaux, recouvrements ou dispositifs de protection pour l'entretien.
- Remettre les portes, panneaux, recouvrements ou dispositifs de protection quand l'entretien est terminé et avant de rebrancher l'alimentation électrique.

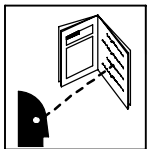

LIRE LES INSTRUCTIONS.

- Lisez le manuel d'instructions avant l'utilisation ou la maintenance de l'appareil.
- N'utiliser que les pièces de rechange recommandées par le constructeur.
- Effectuer régulièrement le contrôle et l'entretien de l'installation.
- Maintenir soigneusement fermés les portes et les panneaux des sources de haute fréquence, maintenir les éclateurs à une distance correcte et utiliser une terre et un blindage pour réduire les interférences éventuelles.

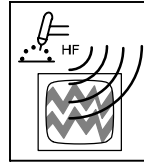

LE RAYONNEMENT HAUTE FRÉQUENCE (H.F.) risque de provoquer des interférences.

- Le rayonnement haute fréquence (H.F.) peut provoquer des interférences avec les équipements de radio-navigation et de communication, les services de sécurité et les ordinateurs.
- Demander seulement à des personnes qualifiées familiarisées avec des équipements électroniques de faire fonctionner l'installation.
- L'utilisateur est tenu de faire corriger rapidement par un électricien qualifié les interférences résultant de l'installation.
- Si le FCC signale des interférences, arrêter immédiatement l'appareil.

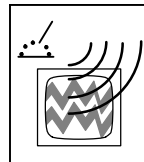

LE SOUDAGE À L'ARC risque de provoquer des interférences.

- L'énergie électromagnétique risque de provoquer des interférences pour l'équipement électronique sensible tel que les ordinateurs et l'équipement commandé par ordinateur tel que les robots.
- Veiller à ce que tout l'équipement de la zone de soudage soit compatible électromagnétiquement.
- Pour réduire la possibilité d'interférence, maintenir les câbles de soudage aussi courts que possible, les grouper, et les poser aussi bas que possible (ex. par terre).
- Veiller à souder à une distance de 100 mètres de tout équipement électronique sensible.
- Veiller à ce que ce poste de soudage soit posé et mis à la terre conformément à ce mode d'emploi.
- En cas d'interférences après avoir pris les mesures précédentes, il incombe à l'utilisateur de prendre des mesures supplémentaires telles que le déplacement du poste, l'utilisation de câbles blindés, l'utilisation de filtres de ligne ou la pose de protecteurs dans la zone de travail.

2-4. Proposition californienne 65 Avertissements

⚠ Les équipements de soudage et de coupage produisent des fumées et des gaz qui contiennent des produits chimiques dont l'État de Californie reconnaît qu'ils provoquent des malformations congénitales et, dans certains cas, des cancers. (Code de santé et de sécurité de Californie, chapitre 25249.5 et suivants)

⚠ Les batteries, les bornes et autres accessoires contiennent du plomb et des composés à base de plomb, produits chimiques dont l'État de Californie reconnaît qu'ils provoquent des cancers et des malformations congénitales ou autres problèmes de procréation. Se laver les mains après manipulation.

Pour les moteurs à essence :

⚠ Les gaz d'échappement des moteurs contiennent des produits chimiques dont l'État de Californie reconnaît qu'ils provoquent des cancers et des malformations congénitales ou autres problèmes de procréation.

Pour les moteurs diesel :

⚠ Les gaz d'échappement des moteurs diesel et certains de leurs composants sont reconnus par l'État de Californie comme provoquant des cancers et des malformations congénitales ou autres problèmes de procréation.

2-5. Principales normes de sécurité

Safety in Welding, Cutting, and Allied Processes, ANSI Standard Z49.1, de Global Engineering Documents (téléphone : 1-877-413-5184, site Internet : www.global.ihc.com).

Recommended Safe Practices for the Preparation for Welding and Cutting of Containers and Piping, American Welding Society Standard AWS F4.1 de Global Engineering Documents (téléphone : 1-877-413-5184, site Internet : www.global.ihc.com).

National Electrical Code, NFPA Standard 70, de National Fire Protection Association, P.O. Box 9101, Quincy, MA 02269-9101 (téléphone : 617-770-3000, site Internet : www.nfpa.org).

Safe Handling of Compressed Gases in Cylinders, CGA Pamphlet P-1, de Compressed Gas Association, 4221 Walney Road, 5th Floor, Chantilly, VA 20151 (téléphone : 703-788-2700, site Internet : www.cganet.com).

Code for Safety in Welding and Cutting, CSA Standard W117.2, de Canadian Standards Association, 5060 Mississauga, Ontario, Canada

L4W 5NS (téléphone : 800-463-6727 ou à Toronto 416-747-4044, site Internet : www.csa-international.org).

Safe Practice For Occupational And Educational Eye And Face Protection, ANSI Standard Z87.1, de American National Standards Institute, 11 West 43rd Street, New York, NY 10036-8002 (téléphone : 212-642-4900, site Internet : www.ansi.org).

Standard for Fire Prevention During Welding, Cutting, and Other Hot Work, NFPA Standard 51B, de National Fire Protection Association, P.O. Box 9101, Quincy, MA 02269-9101 (téléphone : 617-770-3000, site Internet : www.nfpa.org).

OSHA, Occupational Safety and Health Standards for General Industry, Title 29, Code of Federal Regulations (CFR), Part 1910, Subpart Q, and Part 1926, Subpart J, de U.S. Government Printing Office, Superintendent of Documents, P.O. Box 371954, Pittsburgh, PA 15250-7954 (téléphone : 1-866-512-1800) (il y a 10 bureaux régionaux--le téléphone de la région 5, Chicago, est 312-353-2220, site Internet : www.osha.gov).

2-6. Information EMF

Considérations sur le soudage et les effets de basse fréquence et des champs magnétiques et électriques.

Le courant de soudage, pendant son passage dans les câbles de soudage, causera des champs électromagnétiques. Il y a eu et il y a encore un certain souci à propos de tels champs. Cependant, après avoir examiné plus de 500 études qui ont été faites pendant une période de recherche de 17 ans, un comité spécial ruban bleu du National Research Council a conclu : « L'accumulation de preuves, suivant le jugement du comité, n'a pas démontré que l'exposition aux champs magnétiques et champs électriques à haute fréquence représente un risque à la santé humaine ». Toutefois, des études sont toujours en cours et les preuves continuent à être examinées. En attendant que les conclusions finales de la recherche soient établies, il vous serait souhaitable de réduire votre exposition aux champs électromagnétiques pendant le soudage ou le coupage.

Pour réduire les champs magnétiques sur le poste de travail, appliquer les procédures suivantes :

1. Garder les câbles ensemble, les torsader, les scotcher, ou les recouvrir d'une housse.
2. Disposer les câbles d'un côté et à distance de l'opérateur.
3. Ne pas courber pas et ne pas entourer pas les câbles autour de votre corps.
4. Garder le poste de soudage et les câbles le plus loin possible de vous.
5. Connecter la pince sur la pièce aussi près que possible de la soudure.

En ce qui concerne les implants médicaux :

Les porteurs d'implants doivent d'abord consulter leur médecin avant de s'approcher des opérations de soudage à l'arc, de soudage par points, de gougeage, du coupage plasma ou de chauffage par induction. Si le médecin approuve, il est recommandé de suivre les procédures précédentes.

SECTION 3 – INTRODUCTION

3-1. Specifications

Type of Input Power	Welding Power Source Type	Wire Feed Speed Range	Wire Diameter Range	Welding Circuit Rating	Weight
24 Volts AC Single-Phase 10 Amperes 50/60 Hertz	Constant Voltage (CV) DC With 14-Pin And Contactor Control	Standard: 50 To 780 ipm (1.3 To 19.8 mpm) Optional High Speed: 92 To 1435 ipm (2.3 To 36.5 mpm)	.023 To 1/8 in (0.6 To 3.2 mm) Max Spool Weight: 60 lb (27 kg)	100 Volts, 750 Amperes, 100% Duty Cycle	12 ft (3.7 m): 207 lb (94 kg) 16 ft (4.9 m): 280 lb (127 kg)

	12 ft (3.7 m) Boom (DS-12)	16 ft (4.9 m) Boom (DS-16)
Maximum Height With 4 ft (1.2 m) Post	17 ft (5.2 m)	21 ft (6.4 m)
Vertical Lift Of Boom	Horizontal to 60° Above Horizontal	Horizontal to 60° Above Horizontal

SECTION 4 – INSTALLATION

4-1. Installing Swivel Into Pipe Post



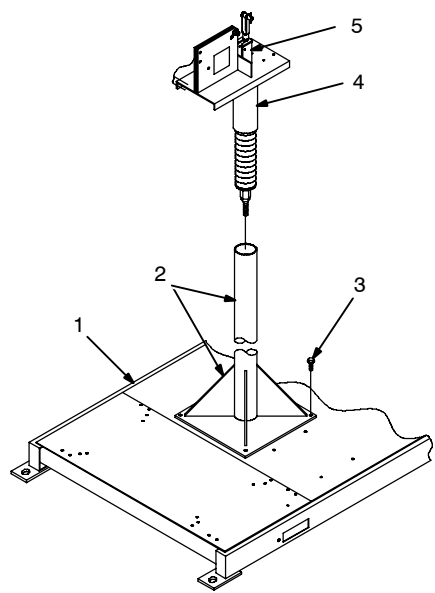

⚠ Do not remove Safety Collar until instructed to.

- 1 Swingpak Base or CBC Cart
- 2 Pipe Post With Base
- 3 Steel Bolt

Secure as shown using as a minimum 1/2 in diameter SAE grade 5 steel bolts.

- 4 Swivel Assembly

Insert into pipe post. Lubricate swivel.

- 5 Safety Collar

Tools Needed:

 3/4 in

152 268-B

4-2. Installing Control Box And Adjusting Tilt

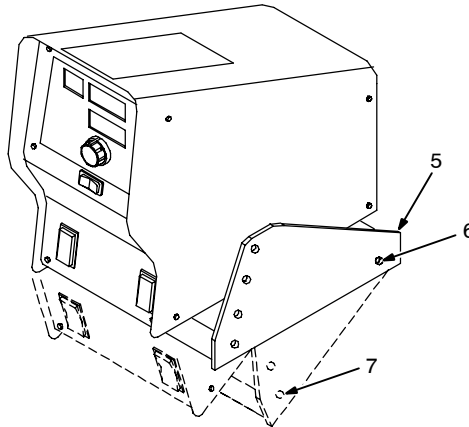
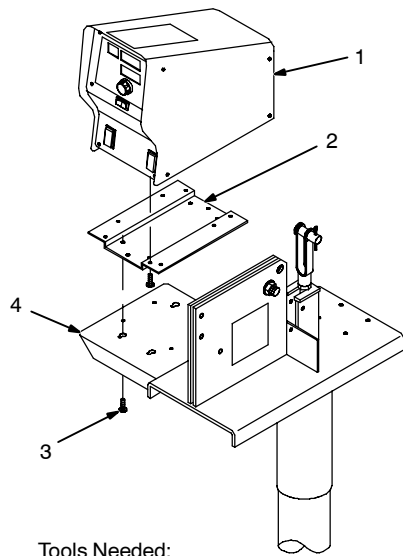

- 1 Weld Control
- 2 Bracket
- 3 Screw

Bracket and screws are installed onto bottom of control at factory.

- 4 Swivel

Loosen screws. Place control on swivel and slide forward. Tighten screws.

- 5 Tilt Bracket
- 6 Rear Pivot Screw
- 7 Front Screw

Loosen rear pivot screw. Remove front screw. Pivot control downward to desired viewing angle. Replace and tighten front screw. Tighten pivot screw.

Tools Needed:

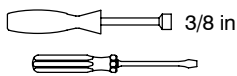

803 192

4-3. Installing Boom And Reel Support

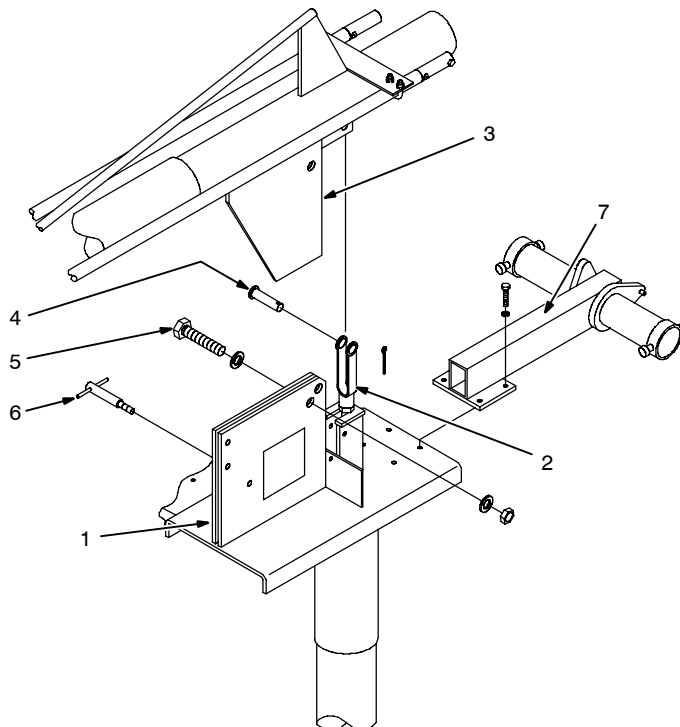

- 1 Swivel Plates
- 2 Yoke

Remove hardware from swivel plates and yoke.

- 3 Boom

Set boom into swivel as shown.

- 4 Yoke Pin

Install pin through yoke. Install cotter pin and spread ends.

- 5 Bolt

Install bolt, washers, and nut. Tighten hardware, and back bolt off one half turn.

- 6 Locking Knob

Install locking knob but do not tighten.

- 7 Reel Support

Install reel support.

Tools Needed:



ST-153 170-A

4-4. Installing Wire Guide Extension

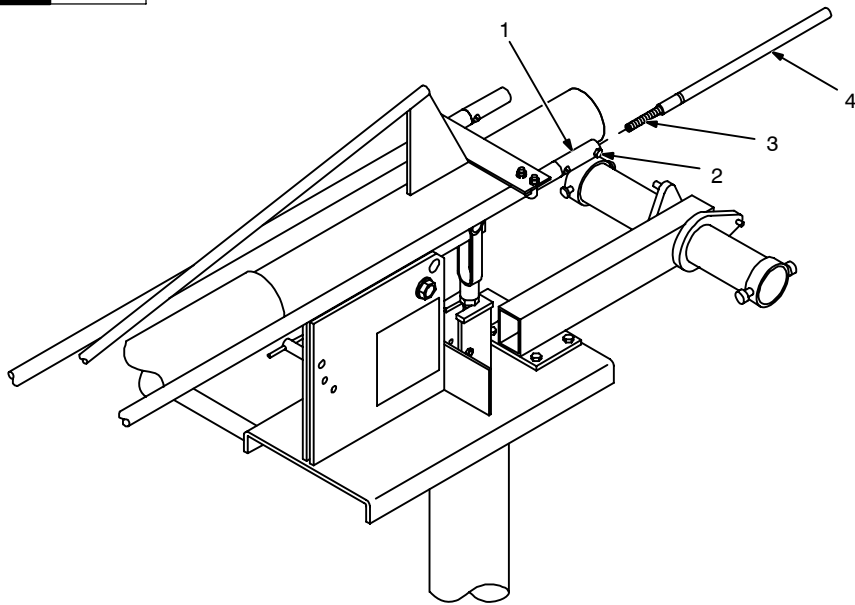

- 1 Wire Guide Fitting
- 2 Bolt
- 3 Monocoil Liner
- 4 Wire Guide Extension

Tighten bolt to secure liner in wire guide fitting. Do not overtighten bolt and crush liner.

Repeat procedure for opposite side.

Tools Needed:



3/8 in

ST-152 383

4-5. Equipment Connection Diagram



- 1 Welding Power Source
- 2 Remote 14 Connection
- 3 Negative (-) Weld Output Cable
- 4 Positive (+) Weld Output Cable
- 5 Workpiece
- 6 Weld Control
- 7 Boom
- 8 Gun
- 9 Swivel
- 10 Pipe Post And Base
- 11 Gas Hose
- 12 Gas Supply and Regulator (Customer Supplied)

 Shielding gas pressure not to exceed 100 PSI (689 kPa).

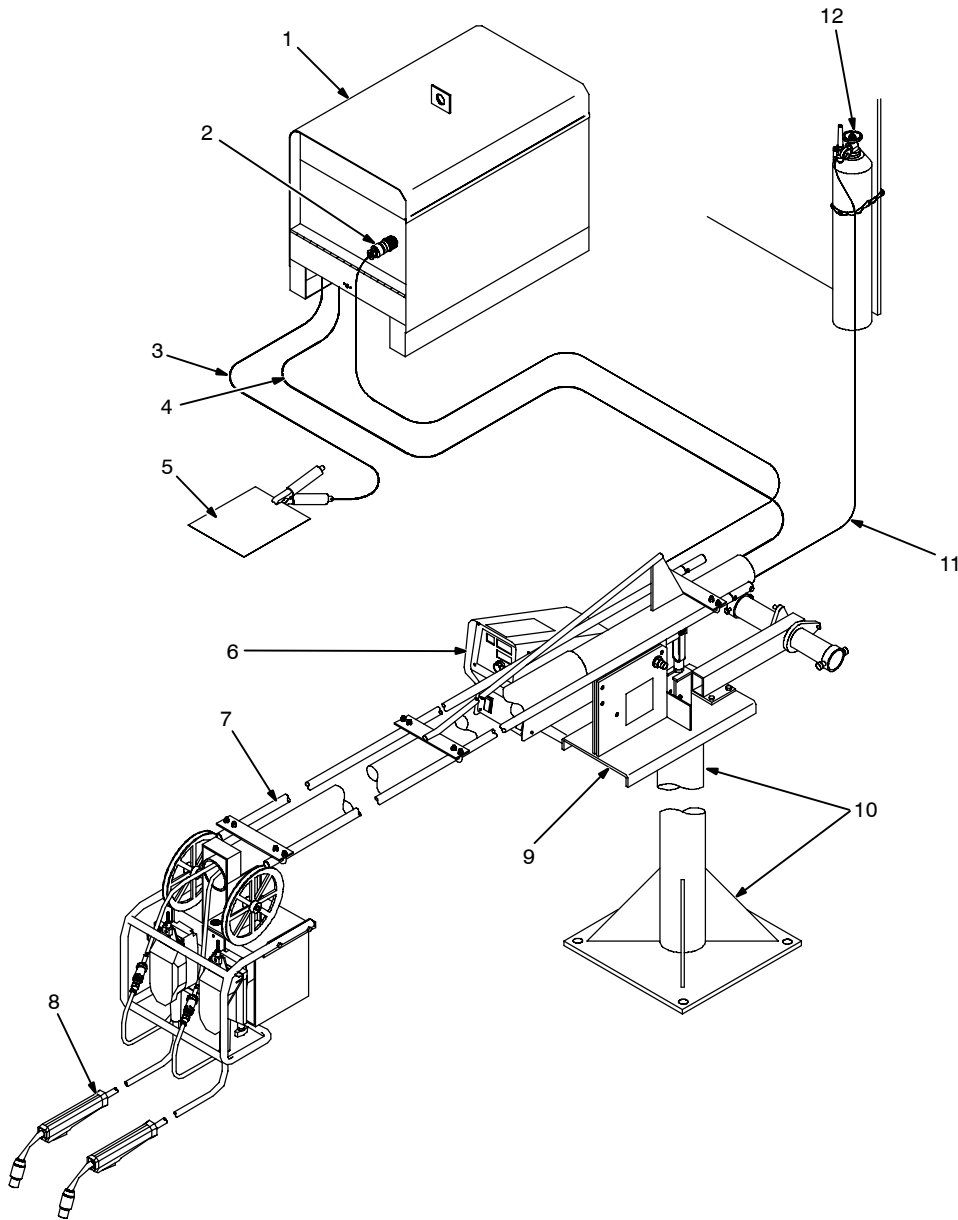

4-6. Control Box Connections

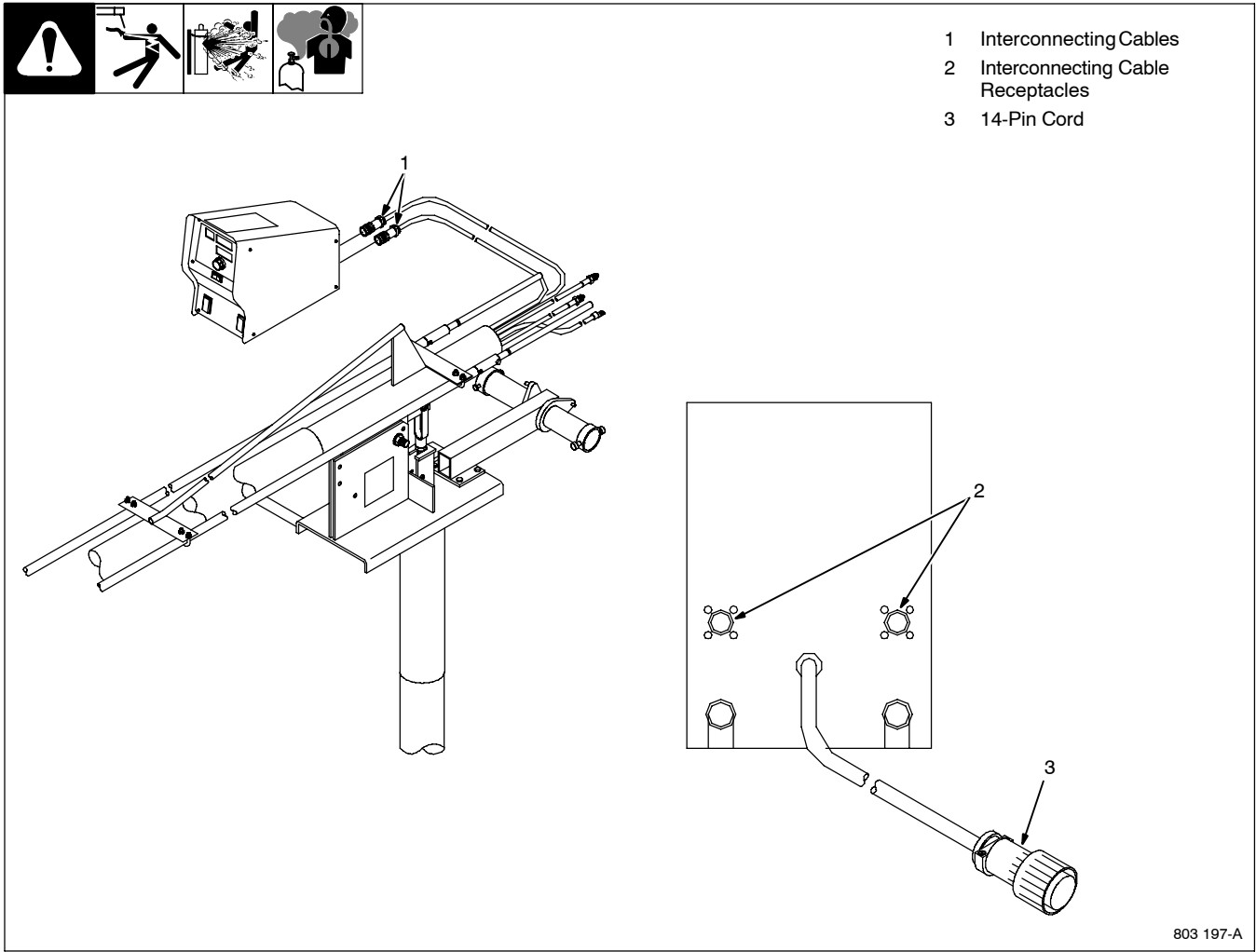

4-7. 14-Pin Plug Information

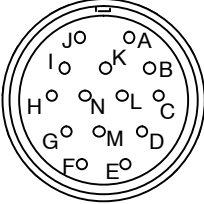
 REMOTE 14	Pin*	Pin Information
	A	24 volts ac with respect to socket G.
	B	Contact closure to A completes 24 volts ac contactor control circuit.
	G	Circuit common for 24 volts AC circuit.
	C	+10 volts dc input from power source to wire feeder with respect to socket D.
	D	Remote control circuit common.
	E	0 to +10 volts dc output signal from wire feeder to power source with respect to socket D.
	H	Voltage feedback; 0 to +10 volts dc, 1 volt per 10 arc volts.
	F	Current feedback; 0 to +10 volts dc, 1 volt per 100 amperes.

*The remaining pins are not used.

4-8. Removing Safety Collar And Adjusting Boom

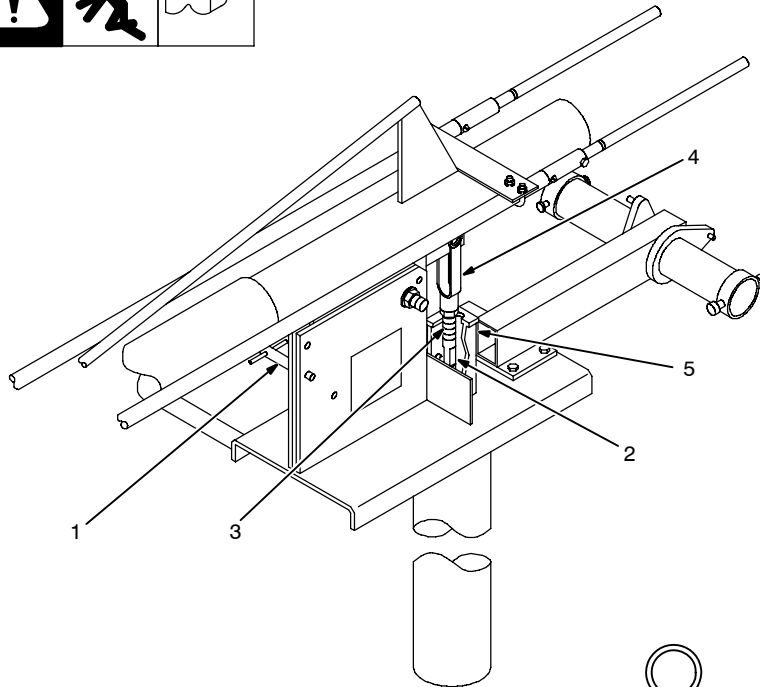

1 Locking Knob

Tighten knob to prevent boom movement. Loosen knob to allow boom movement. Change knob position to limit upward movement.

Pull boom down slightly and remove safety collar. Boom should balance in any position from horizontal to 60 degrees above horizontal. If necessary, adjust boom as follows:

2 Threaded Rod

3 Jam Nut

Loosen jam nut and turn threaded rod until boom balances. Tighten jam nut. Be sure several full threads are through yoke to prevent boom falling.

4 Yoke

5 Safety Collar

Retain safety collar for use in disassembling or moving boom.

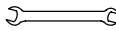
Tools Needed:
 1-1/8 in

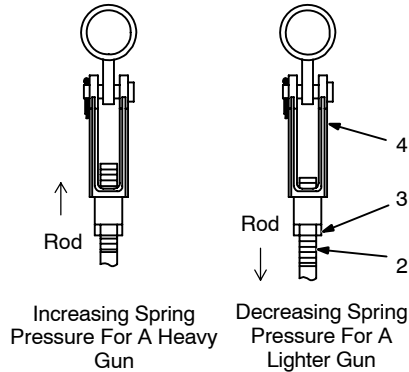

ST-142 599-C

4-9. Gun Recommendation Table

Process	Gun
GMAW – Hard or Cored Wires	Roughneck C-Series Guns: 300, 400, 500, And 600 Amp.
FCAW – Self-Shielding Wires	FC-1260 Or FC-1150

4-10. Wire Type, Size, And Feed Speed Capability Table

Motor Speed	Wire Type	Wire Size	Feed Speed Capability
Standard	All	.023 To 5/64 in (0.6 To 2 mm)	50 To 780 ipm (1.3 To 19.8 mpm)
Standard	All	3/32 To 7/64 in (2.4 To 2.8 mm)	50 To 700 ipm (1.3 To 17.8 mpm)
Standard	All	1/8 in (3.2 mm)	50 To 300 ipm (1.3 To 7.6 mpm)
Optional High Speed	All	.023 To 5/64 in (0.6 To 2 mm)	92 To 1435 ipm (2.3 To 35.6 mpm)

4-11. Installing And Threading Welding Wire



Tools Needed:

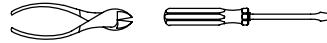

3/16, 5/64 in 3/8, 15/16 in

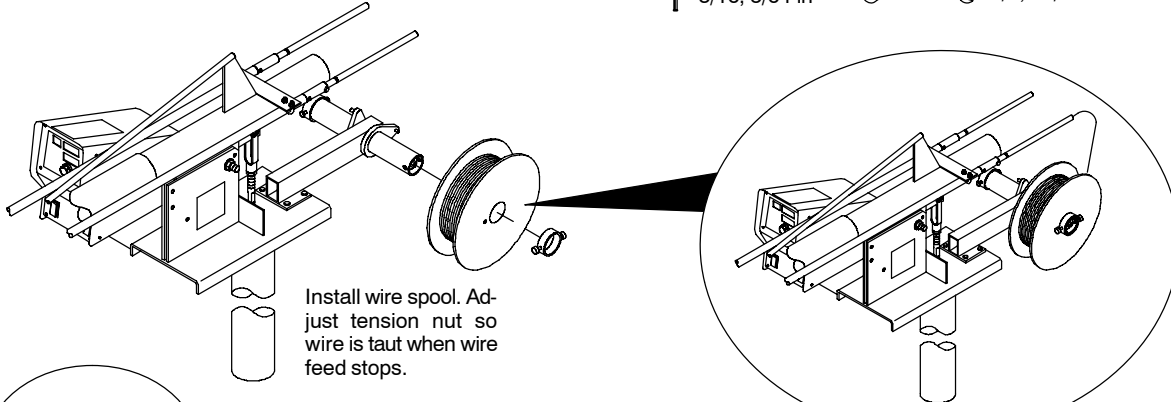

Install wire spool. Adjust tension nut so wire is taut when wire feed stops.

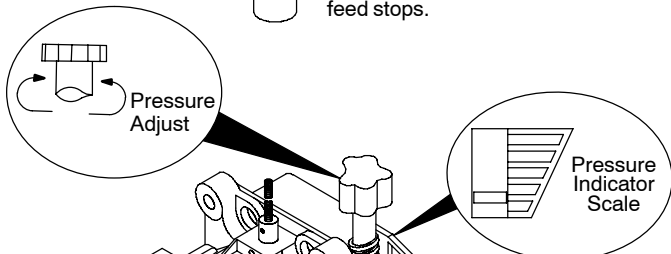

Pressure Adjust

Pressure Indicator Scale

Pressure Adjust

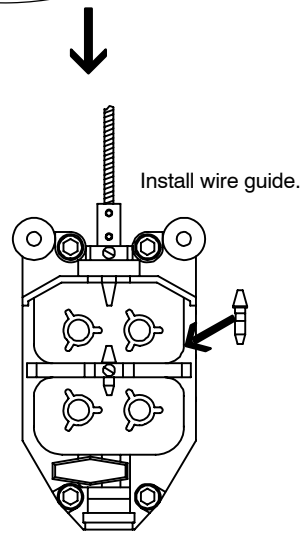

Install wire guide.

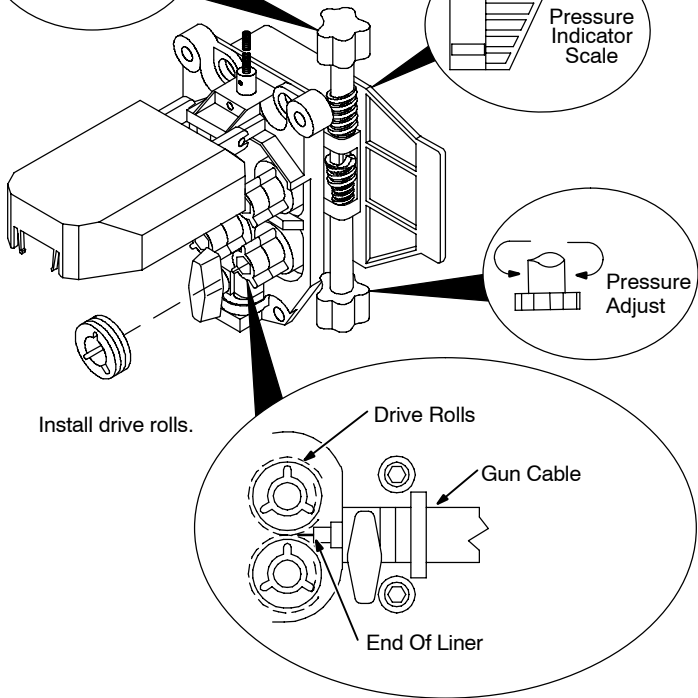

Install drive rolls.

Drive Rolls

Gun Cable

End Of Liner

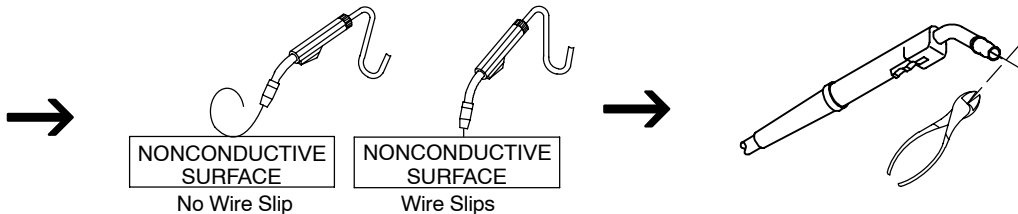

NONCONDUCTIVE SURFACE

No Wire Slip

NONCONDUCTIVE SURFACE

Wire Slips

☞ Be sure that outlet cable has proper size liner for the welding wire size. **When installing gun, position liner extending from outlet wire guide as close as possible to drive rolls without touching.**

☞ For soft wire or small diameter stainless steel wire, reduce drive roll pressure on the rear roll to half that of the front rolls.

☞ To adjust drive roll pressure, hold nozzle about 2 in (51 mm) from nonconductive surface and press gun trigger to feed wire against surface. Tighten knob so wire does not slip. Do not overtighten. If contact tip is completely blocked, wire should slip at the feeder (see pressure adjustment above). Cut wire off. Close cover.

Install gun. Lay gun cable out straight. Cut off end of wire. Push wire through guides up to drive rolls; continue to hold wire. Press Jog button to feed wire out gun.

4-12. Setting Internal DIP Switches



- 1 DIP Switch S1
- 2 DIP Switch S4 (Not For Customer Use)

DIP switch S1 allows the user to make a number of choices affecting unit operation.

- **Defining Motor Speed (S1-7 & 8)**

Switches 7 and 8 allow the user to define whether the motor in use is standard speed (50-780 inches per minute), or high speed (92-1435 inches per minute).

☞ *Setting DIP switches allows the feeder to display the proper wire speed. Setting the DIP switches will not change the speed range of the motors.*

☞ *When DIP switch positions are changed, the unit must be turned Off and then On again in order for the new settings to be active. DIP switches are only read on power up.*

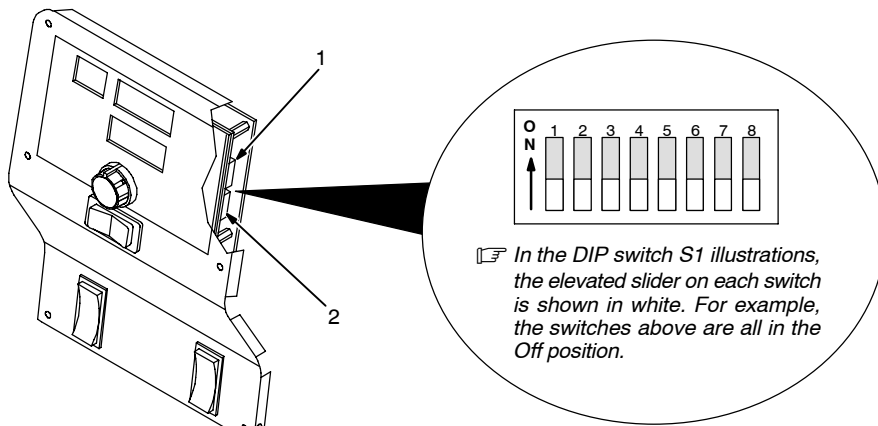

803 198

Position Settings And Results For DIP Switch S1

7	8	
☐	☐	
7 Off, 8 Off = Standard speed motor (50-780 inches per minute, or 1.2-19.8 meters per minute)		

7	8	
☐	☐	
7 Off, 8 On = High speed motor (92-1435 inches per minute, or 2.3-36.4 meters per minute)		

4-13. Power Source Selection Menu

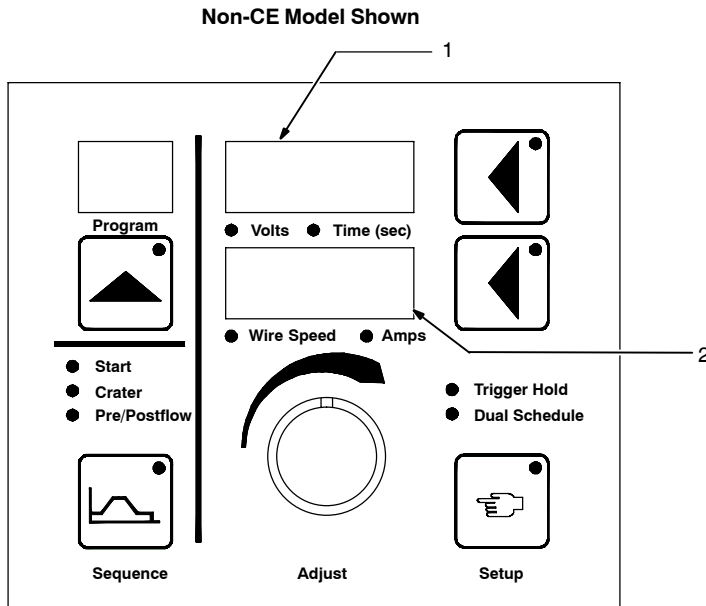

- 1 Upper Display
- 2 Lower Display

☞ When the feeder is turned on, the Power Source Selection Menu allows the operator to select a default power source. Selecting a default power source, automatically sets the correct V_{min} and V_{max} settings for adjusting the output voltage of the power source.

First Time Feeder Is Turned On

The feeder automatically goes into the Power Source Selection Menu. The feeder displays "dELT" on the Upper Display and "452" on the Lower Display, meaning that a Deltaweld 452 is the default power source, and has a voltage range of 10V as V_{min} and 38V as V_{max} .

At power up, the operator has three seconds to select a default power source from the list shown on the display. Operator may scroll through the list of power sources by using the Adjust control. After selecting a power source the operator has three seconds to change to a different power source or begin welding. After making a power source selection, the operator may press the Program Button to avoid having to wait the three seconds. When turning off the feeder, the default power source will be retained.

If voltage settings have already been set with the V_{min} and V_{max} in the Auxiliary Menu, selecting a default power source with the Power Source Selection Menu overrides the V_{min} and V_{max} voltage settings.

Next Time Feeder Is Turned On

The feeder will display the last selected default power source. The operator has three seconds to select another power source, or press the Program Button to exit the Power Source Selection Menu.

Disabling The Power Source Selection Menu

Once the default power source has been selected the Power Source Selection Menu may be disabled using the Auxiliary Menus. See Section 5-12.

** Power Source	Upper Display	Lower Display	Voltage Range	
Deltaweld 452	dELT	452	$V_{min} = 10$	$V_{max} = 38$
Deltaweld 302	dELT	302	$V_{min} = 10$	$V_{max} = 32$
Deltaweld 652	dELT	652	$V_{min} = 10$	$V_{max} = 44$
Dimension 302	dIM	302	$V_{min} = 10$	$V_{max} = 32$
Dimension 452	dIM	452	$V_{min} = 10$	$V_{max} = 38$
Dimension 652	dIM	652	$V_{min} = 10$	$V_{max} = 65$
Dimension 1000	dIM	1000	$V_{min} = 10$	$V_{max} = 60$
XMT 304	XMT	304	$V_{min} = 10$	$V_{max} = 35$
XMT 456	XMT	456	$V_{min} = 10$	$V_{max} = 38$
Invision 354MP	I354	MP	$V_{min} = 10$	$V_{max} = 35$
Invision 456MP	I456	MP	$V_{min} = 10$	$V_{max} = 38$
Invision 456P	I456	P	$V_{min} = 10$	$V_{max} = 38$
PHOENIX 456	PHX	456	$V_{min} = 10$	$V_{max} = 38$
SUMMITARC 1000	SUM	1000	$V_{min} = 25$	$V_{max} = 44$

** For any power sources not listed, pick a matching voltage range, or see Sec 4-12 to set V_{min} and V_{max} .

SECTION 5 – OPERATION

5-1. Operational Terms

The following is a list of terms and their definitions as they apply to this wire feeder:

General Terms:

Cold Wire Jog	Feeding wire without contactor or gas valve being energized.
Sequence	A portion of the weld program, such as preflow, run-in, start, weld, crater, burnback, and postflow.
Weld Program	A group of sequences that make up a weld cycle.

5-2. Power Switch

1 Power Switch

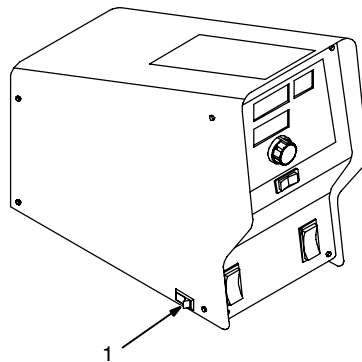

803 193

5-3. Left/Right Select Switch

1 Left/Right Select Switch

Pressing the Left/Right Select switch allows the operator to choose which side of the units' controls will operate.

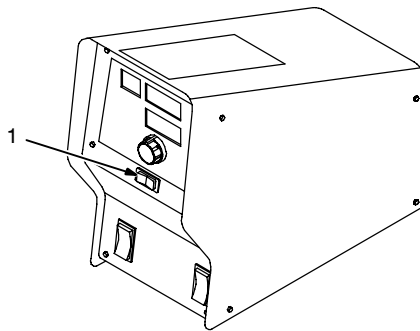

☞ *Engaging the Left or Right Gun Trigger also allows the operator to enable the controls on that side of the unit.*

803 194

5-4. Jog/Purge Switch

- 1 Jog/Purge Switch
- 2 Adjust Control

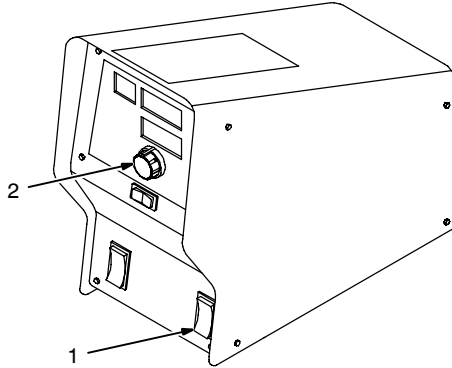

803 194

Pressing the Jog/Purge switch allows the operator to jog wire without energizing the weld power or gas valve circuit.

- The unit provides the ability to jog the wire feeder by means of the gun trigger or the Jog/Purge switch. If the welding arc does not initiate in 3 seconds after the gun trigger is activated, the unit will perform a jog operation for a maximum of two minutes. If the gun

trigger is still activated after two minutes, the jog operation is terminated to prevent complete despooling of the wire, in the case of a damaged gun.

- The unit displays the "ERR TRIG" message to inform the operator that the trigger is activated.
- Jog speed can be adjusted by the Adjust control when the unit is jogging wire. The

unit displays jog speed when the unit is being jogged.

- Jogging can also be accomplished by pressing the Jog/Purge button.
- Pressing the Jog/Purge button also allows the operator to purge gas lines before welding and to preset gas pressure at the regulator.

5-5. Front Panel Controls

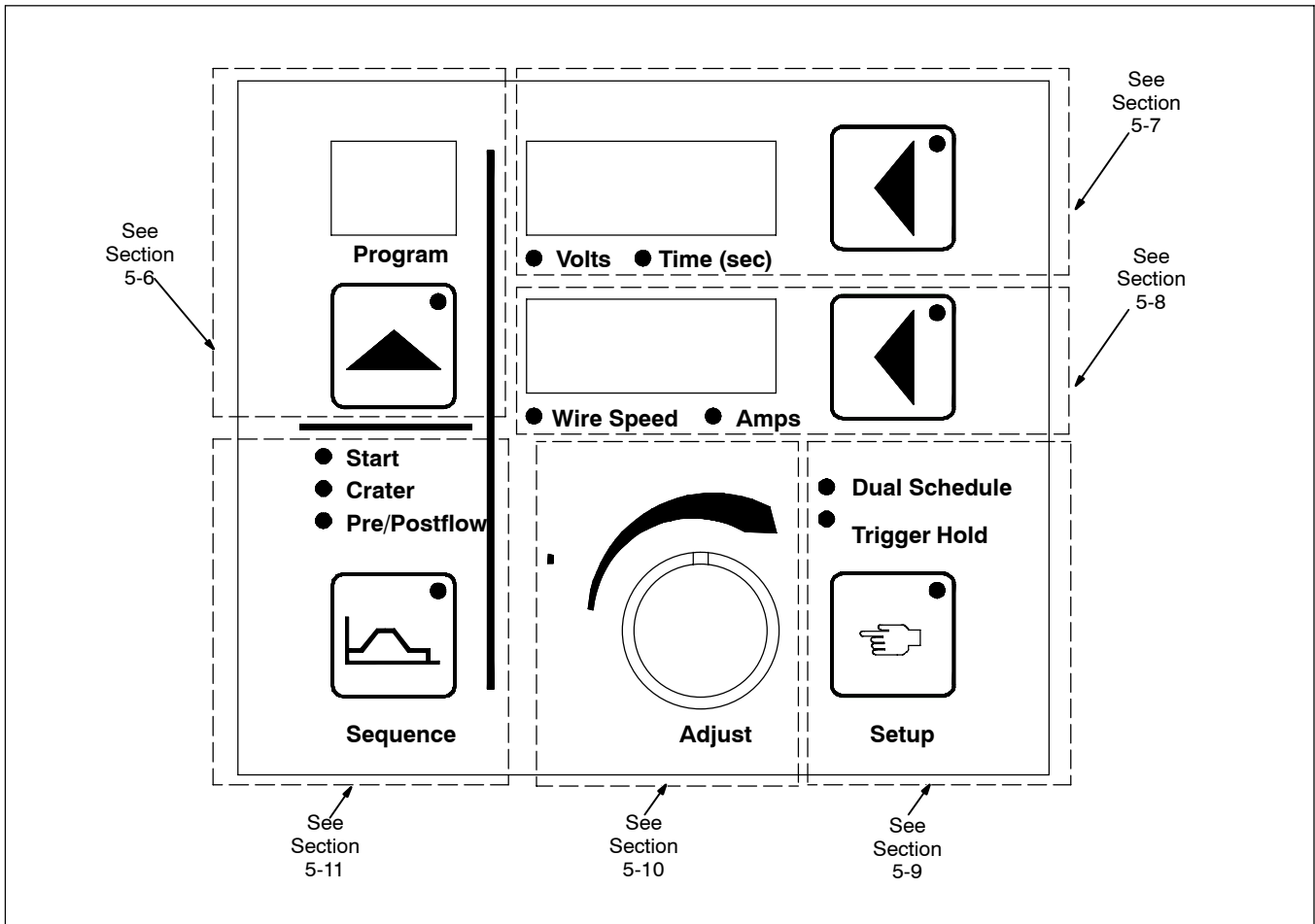

5-6. Program Push Button

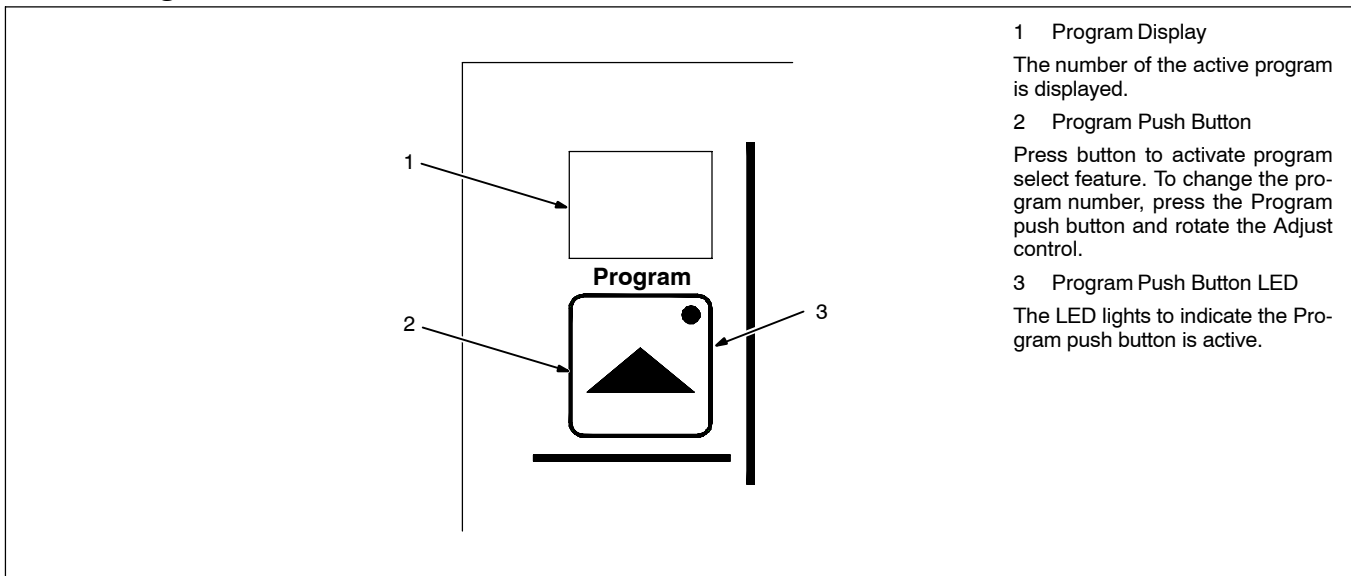

- 1 Program Display
The number of the active program is displayed.
- 2 Program Push Button
Press button to activate program select feature. To change the program number, press the Program push button and rotate the Adjust control.
- 3 Program Push Button LED
The LED lights to indicate the Program push button is active.

5-7. Upper Display

 To set the correct voltage range for a particular power source, see Section 4-13 for power source selection menu, or Section 5-12 for V-Min And V-Max adjustments.

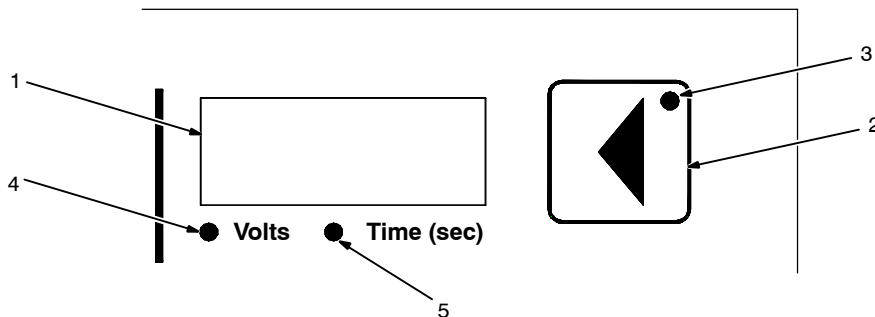

1 Upper Display

The upper display shows voltage or time. The unit displays both preset and actual arc voltage. When the unit is in a welding state, actual arc voltage is displayed. The upper display shows welding sequence time when the Time LED is illuminated.

2 Upper Display Push Button

Press and hold button to adjust or display weld time. Release button to display voltage.

3 Upper Display Push Button LED

The upper display push button LED illuminates to indicate that information displayed can be changed by the Adjust control.

At any time while welding, the unit permits the adjustment of the weld sequence voltage and overrides the display of actual arc voltage.

4 Volts LED

5 Time LED

The LEDs below the display illuminate to indicate which value is being shown.

At any time while welding, the unit permits the adjustment of the weld sequence voltage and overrides the display of actual arc voltage.

- If the unit is displaying a welding sequence that can be timed, the welding time display mode is entered by pressing the upper display push button repeatedly until welding time is the active parameter in the upper display. At idle, the upper display toggles between showing weld voltage or weld time, with subsequent presses of the upper display push button.

play push button repeatedly until welding time is the active parameter in the upper display. At idle, the upper display toggles between showing weld voltage or weld time, with subsequent presses of the upper display push button.

- The unit defaults to displaying welding voltage when a welding sequence display mode is first entered.
- If the weld sequence has a time set (as in spot time), after the weld program is completed, ERR TRG 1 will be displayed to indicate the weld program is complete. Release trigger to clear error.

5-8. Lower Display

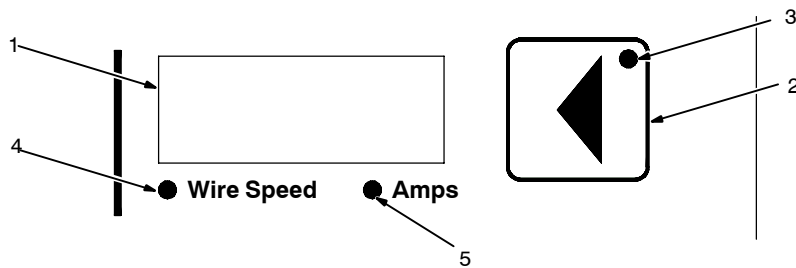

1 Lower Display

The lower display shows wire speed or amperage. The unit displays and adjusts only preset wire speed at idle. When the unit is in a welding state, actual wire speed is displayed for the active welding sequence.

2 Lower Display Push Button

Press button to choose between wire speed or amperage functions.

3 Lower Display Push Button LED

The lower display push button LED illuminates

to indicate that information displayed can be changed by the Adjust control.

4 Wire Speed LED

5 Amps LED

The LEDs below the display illuminate to indicate which value is being shown.

- If the unit is in a welding state that does not involve feeding wire, the unit displays the weld sequence wire speed. At any time during welding, the weld sequence wire speed can be adjusted and overrides the preset wire speed display. In other words, if the Ad-

just control is activated while welding, the unit displays and permits adjustment of the weld sequence wire feed speed regardless of the active welding sequence.

- When the unit is displaying amperage, the Amps LED illuminates. Amperage is only displayed if the unit is in a welding state and the amperage is above a minimum value of 25 Amps.
- The display will read dashes for amperage readings below the amperage threshold, prior to arc initiation.

5-9. Setup Push Button

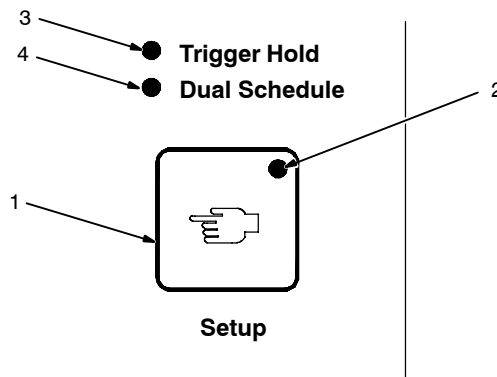

1 Setup Push Button

Press button to choose between trigger hold or dual schedule functions.

2 Setup Push Button LED

3 Trigger Hold LED

4 Dual Schedule LED

- When the Setup button is pressed, the Setup push button LED flashes and the Trigger Hold LED flashes.
- The flashing LED indicates that the unit is in the trigger hold display mode. In this mode the upper display indicates HOLD and the lower display indicates the trigger hold status On/Off. Use the Adjust control to change

the trigger hold status or press the lower display push button. If trigger hold is turned On, the trigger hold LED illuminates and stays On.

- When trigger hold is On, the user must press and hold the trigger for a predefined amount of time (the trigger hold delay time—see Section 5-12), then release it for the trigger hold function to be active. To shut off the weld when trigger hold is On, the user must press and release the trigger.
- If a weld time is programmed, trigger hold is disabled.
- Trigger hold and dual schedule cannot be used concurrently.

- When the Setup button is pressed a second time, the dual schedule LED flashes. In this mode the upper display indicates DUAL and the lower display indicates dual schedule status On/Off. Use the Adjust control to change the dual schedule status if desired.
- Pressing the Setup button again exits the Setup mode. The dual schedule LED stops flashing to indicate the dual schedule status is Off.
- While in the Setup mode, the active program can be adjusted without deactivating the trigger hold Setup mode operation. If the trigger is activated, Setup mode(s) is terminated.

5-10. Adjust Control

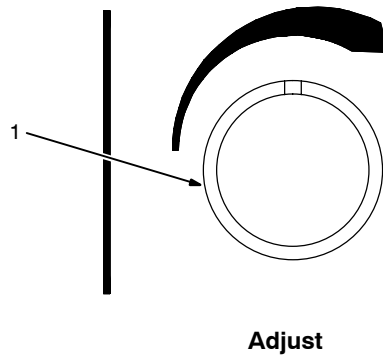

1 Adjust Control

The Adjust control is used to change various sequence parameters, and to select various sequences. Refer to the section for the function in question for information related to using the Adjust control.

5-11. Sequence Push Button

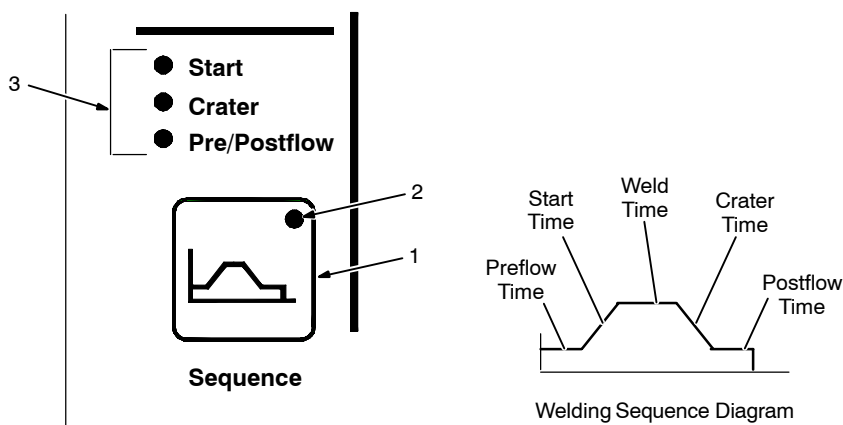

- 1 Sequence Push Button
- 2 Sequence Push Button LED
- 3 Welding Sequence LEDs

For more information on Setting Sequence Parameters see Section 6-1.

- The Sequence push button allows the selection of welding sequences. Five welding sequences are available. The default sequence is the Weld sequence. The Weld sequence is active on power up. Three welding sequence LEDs are located above the Sequence push button: Start, Crater, and Preweld/Postflow. The applicable LED illuminates to indicate which welding sequence is active.
- The LED illuminates to indicate that a welding sequence display mode other than Weld is activate. Welding sequences other than Weld must be set prior to initiating the arc. When the unit enters a welding state, all sequence display modes are terminated and

the weld display mode is activated.

If zero time is programmed for a timed sequence except for Weld, that sequence will be skipped.

- In the weld sequence display mode the Sequence push button LED is Off. When the Sequence push button is pressed, the Sequence push button flashes and the Start LEDs flash. In this condition, the unit is in the Start sequence display mode, and Start sequence parameters are shown in the displays.
- When the Sequence push button is pressed a second time, the Crater sequence LED flashes. The Sequence push button LED remains flashing. In this condition, the unit is in the Crater sequence display mode, and Crater sequence parameters are shown in the displays.

- When the Sequence push button is pressed a third time, the Preweld/Postflow sequence LED flashes. The Sequence push button LED remains flashing. In the Preweld display mode the upper display shows the preflow time and the lower display indicates the abbreviation PRE, to inform the operator that preflow time is displayed. If the upper display push button is pressed, the Adjust control can be used to adjust preflow.

If the lower display push button is pressed, the Adjust control can be used to select between preflow PRE and postflow POST. When POST is selected, the upper display can be used to specify postflow time.

- When the Sequence push button is pressed a fourth time, the unit returns to the welding sequence display mode.

5-12. Auxiliary Menus

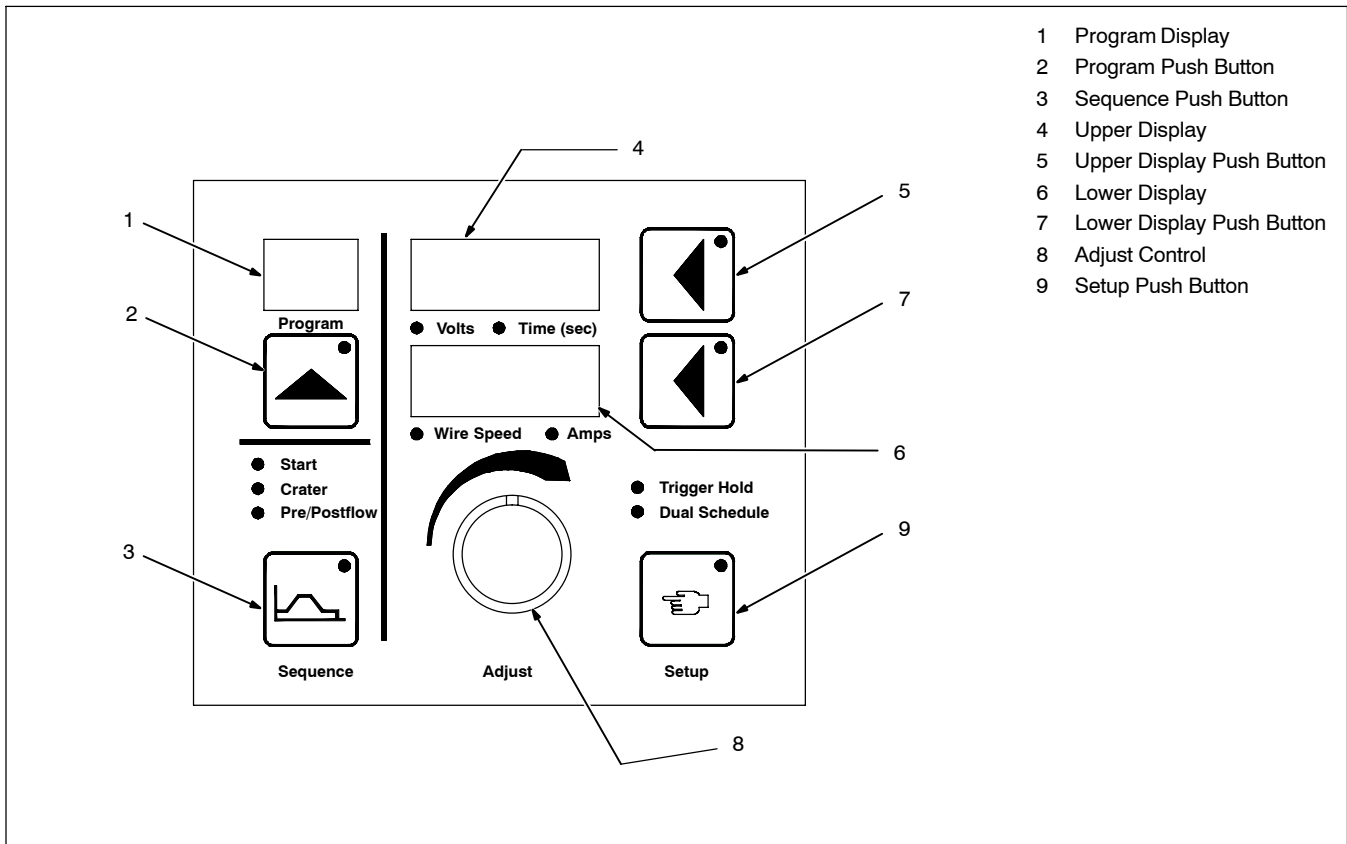

5-12 Auxiliary Menus (Continued)

Reset To Factory Settings

A reset menu is displayed if the following four push buttons are pressed simultaneously: Program, Sequence, upper display, and Setup. The upper display indicates "WIPE". The lower display indicates "OFF". The lower push button is active indicating that the Adjust control can be used to change the unit to "WIPE ON". When "WIPE ON" is set, if the original four push buttons are simultaneously pressed a second time, the unit will reset all settings to factory default except the arc time and arc cycle counts. If a reset is not desired, set the display to "WIPE OFF" and simultaneously press the Program, Sequence, upper display, and Setup push buttons to exit the reset menu.

Auxiliary Menu

- An auxiliary menu is provided if both the Sequence and Setup push buttons are pressed simultaneously. The Setup push button and sequence push button LEDs flash when the auxiliary menu is displayed.

Pushing the Setup push button will step through the menu. Pushing the sequence push button will step through the menu in reverse.

☞ The auxiliary menu may be exited at any time by pressing both the Sequence push button and the Setup push buttons simultaneously.

V-Min And V-Max

- If the Setup push button is pressed, the unit allows the setting of the manual override

power source min and max voltage preset range. The minimum voltage is displayed in the upper display and the lower display indicates "VMIN". When the Setup push button is pressed the unit displays the maximum voltage setting of the welding power source. The maximum voltage is displayed in the upper display and the lower display indicates "VMAX".

In both cases, the Adjust control is used to specify the minimum and maximum voltage settings of the welding power source. The settings correspond to arc voltage obtained at minimum command and arc voltage obtained at maximum command.

This method of setting "VMIN" and "VMAX" may be used if the power source being used is not listed in the Power Source Selection Menu.

☞ If a default power source has already been selected with the Power Source Selection menu, setting "VMIN" and "VMAX" will override the default power source settings.

☞ The power source selection menu must be set to "OFF" when overriding the default "VMIN" or "VMAX" settings.

Power Source Selection Menu

- If the Setup push button is pressed, the unit allows the Power Source Selection menu to be disabled or enabled.

The upper display shows "PSS". Lower display shows "On" or "Off". The Adjust Control is used to select either "On" or "Off".

Arc Time

- If the Setup push button is pressed, the unit displays arc time in hours.

Arc time is indicated by the Program display showing "HR". Arc time is shown in the lower display.

Cycles

- If the Setup push button is pressed, the unit displays the number of cycles.

Arc cycles are indicated by the Program display showing "CL". The arc cycle count is shown in the lower display.

Run-In

- If the Setup button is pressed, the unit allows setting the run-in modes. The run-in modes are program specific. Each program may be set to its own run-in mode.

The upper display indicates "RUNI". The lower display indicates "AUTO", meaning the factory set automatic run-in speed is selected.

Pressing the lower display button allows a manual setting the run-in wire speed. Speed may be adjusted from 10% to 100% of weld wire speed.

Pressing the lower display button allows disabling of the run-in feature. When the lower display indicates "OFF" run-in is disabled.

5-12 Auxiliary Menus (Continued)

Burnback

- If the Setup push button is pressed, the unit allows burnback time to be set.

Burnback time and voltage can be specified when the lower display indicates "BURN" and the upper display indicates the burnback time or voltage. The Adjust control is used to set the desired burnback time or voltage. Burnback settings, like run-in settings, are program specific. The active program is displayed in the Program display and can be adjusted (see Section 5-6).

Trigger Hold Setup

- If the Setup push button is pressed, the unit allows trigger hold delay time to be set.

Trigger hold delay time is indicated by "HOLD" in the lower display and the hold delay time in the upper display. The adjust control can be used to specify a new delay time for trigger hold. Trigger hold delay time is the minimum amount of time the trigger must be held for trigger hold to work when the trigger is released (the trigger hold function must be on). For example, if a trigger hold delay time of 2.0 seconds is defined, the operator must hold the trigger for at least 2 seconds before releasing it in order for the trigger hold function to work. Once the trigger hold function is in effect, the wire feeder will stay On until the trigger is pressed and released again.

- There is an additional function built in called "maximum trigger hold time" which is the maximum length of time the trigger can be held and the trigger hold function still work when the trigger is released (the trigger hold function must be on). The maximum trigger hold time is set at 4.0 seconds after the trigger hold delay time. For example, if a trigger hold delay time of 2.0 seconds is defined, and the operator held the trigger in for more than 6.0 seconds, the trigger hold function would not be in effect and the wire feeder would stop when the trigger is released.
- When the Setup push button is pressed again, the menu repeats to the first menu selection of run-in wire speed selection.

Trigger Program Select

- If the Setup push button is pressed, the unit allows Trigger Program Select or Trigger Dual Schedule to be enabled or disabled.

The upper display shows "TSEL". Lower display shows "OFF" or "PROG" or "DUAL". The Adjust Control is used to select "OFF" or "PROG" or "DUAL".

Trigger Program Select (PROG) allows the operator to select programs during preflow by clicking the trigger (pulling and releasing the trigger in a maximum of 0.2 seconds). The feeder will switch between any programs that have a minimum of 0.2 seconds of preflow time set in the weld sequence. Any combination of

programs may be used. Trigger Program Select cannot be used while welding or with Dual Schedule.

(Example: If programs 1 and 3 have a minimum of 0.2 seconds of preflow time, clicking the trigger will toggle between programs 1 and 3).

Trigger Dual Schedule Select (DUAL) allows the operator to switch between paired schedules (programs 1-2, 3-4, 5-6, or 7-8) with the gun trigger, but only while welding. This feature cannot be used with Trigger Hold or Dual Schedule. To end the weld, the trigger must be released for 0.4 seconds.

(Example: when welding with this feature enabled in program 1, if you release, re-trigger, and hold again within <0.4 seconds, the active program will switch to program 2. If the previous sequence is repeated the active program will switch back to program 1. This cycle can be repeated for the entire weld).

Process Select

Process selection indicated by "PROS" in the upper display is set to either "VOLT" or "TRIM" in the lower display. Each program can be selected be be a MIG program indicated by "VOLT" or a pulsing program indicated by "TRIM".

Range Locks

Range locks are indicated by "LOCK" in the upper display for wire speed or "LOCK" in the lower display for voltage range. In a MIG program, the voltage range lock ranges from 0 to 10 volts. In a pulse program, the trim range lock ranges from 0 to 100. The wire feed speed range lock ranges from 0 to 250 ipm. Locks are program dependent and wire speed is independent from voltage or trim.

Wire Feed Speed Units

Wire feed speed setting indicated by "WFS" in the upper display is set to "IPM" inches-per-minute or "MPM" meters-per-minute. This setting is independent of the program selected.

OPT1

- If the Setup push button is pressed, the unit allows OPT1 to be disabled or enabled.

The upper display shows "OPT1". Lower display shows "On" or "Off". The Adjust Control is used to select either "On" or "Off".

"OPT1" is used by the Water Flow Shutdown Option to stop the weld sequence if water flow to a water cooled gun is interrupted. A closed set of contacts between pins 1 and 2 of RC26 on Interface Board (PC20) will allow feeder to operate normally. Opening the contacts will stop the weld sequence and display "ERR" in the upper display and "OPT1" in the lower display.

OPT2

- If the Setup push button is pressed, the unit allows OPT2 to be disabled or enabled.

The upper display shows "OPT2". Lower display shows "On" or "Off". The Adjust Control is used to select either "On" or "Off".

"OPT2" is a second input that may be used with an external device, such as a gas flow switch, to end the weld sequence. The gas flow switch may be used to stop the weld sequence if shielding gas flow to the gun is interrupted. A closed set of contacts between pins 1 and 2 of RC24 on Interface Board (PC20) will allow feeder to operate normally. Opening the contacts will stop the weld sequence and display "ERR" in the upper display and "OPT2" in the lower display.

Display Hold

Display hold indicated by "DISP" in the upper display is set to "OFF" or "HOLD" in the lower display. When "HOLD" is selected, the unit will hold the last weld information for 5 seconds following weld termination. If any front panel push button is pressed, or if the Adjust control is activated, the display hold feature is terminated.

Software Revision Level

- If the Setup push button is pressed, the unit displays the software version being used by the interface PCB (PC20).
- When the Setup button is pressed again, the menu repeats.

Code

Upon leaving the auxiliary menu, the user is asked if a password code indicated by "CODE" in the top display should be activated. By default the code is off, indicated by "OFF" in the lower display. The user may enter a numerical password between 0 and 999 by turning the Adjust control. When the user re-enters the auxiliary menu, the password code must be selected to gain access to the auxiliary menu. A failed attempt return the user to the weld screen and a counter is incremented. A counter in the program display shows the number of incorrect attempts. The user has five attempts to enter the correct password code before being locked out of the auxiliary menu, indicated by "LOCK" in the lower display. The power may be cycled to continue welding but the user will remain locked out of the auxiliary menu. Pressing the Program, Sequence, upper display, and Set-up push buttons simultaneously, the counter can be reset in the weld screen. Resetting the counter is indicated by "CODE" in the upper display and "RSET" in the lower display. Pressing the Program, Sequence, upper display, and Set-up push buttons simultaneously again will allow the user to reset the unit to the factory defaults, indicated by "WIPE" in the upper display. Resetting the unit will also turn off the password code feature.

SECTION 6 – SETTING SEQUENCE PARAMETERS

6-1. Sequence Parameters In A Program



For more information on Sequence Push Button see Section 5-11.

If time is set to zero in Weld sequence, welding continues until gun trigger is released.

If time is set to zero in any timed sequence except Weld, the sequence is skipped.

Sequence	Parameters		
	Volts	IPM	Seconds
1. Preweld			0-9.9
2. Run-In		X	
3. Start	X	X	0.00-5.00
4. Weld	X	X	0-100.0
5. Crater	X	X	0-5.00
6. Burnback	X		0-0.25
7. Postflow			0-9.9

X = Setting available.

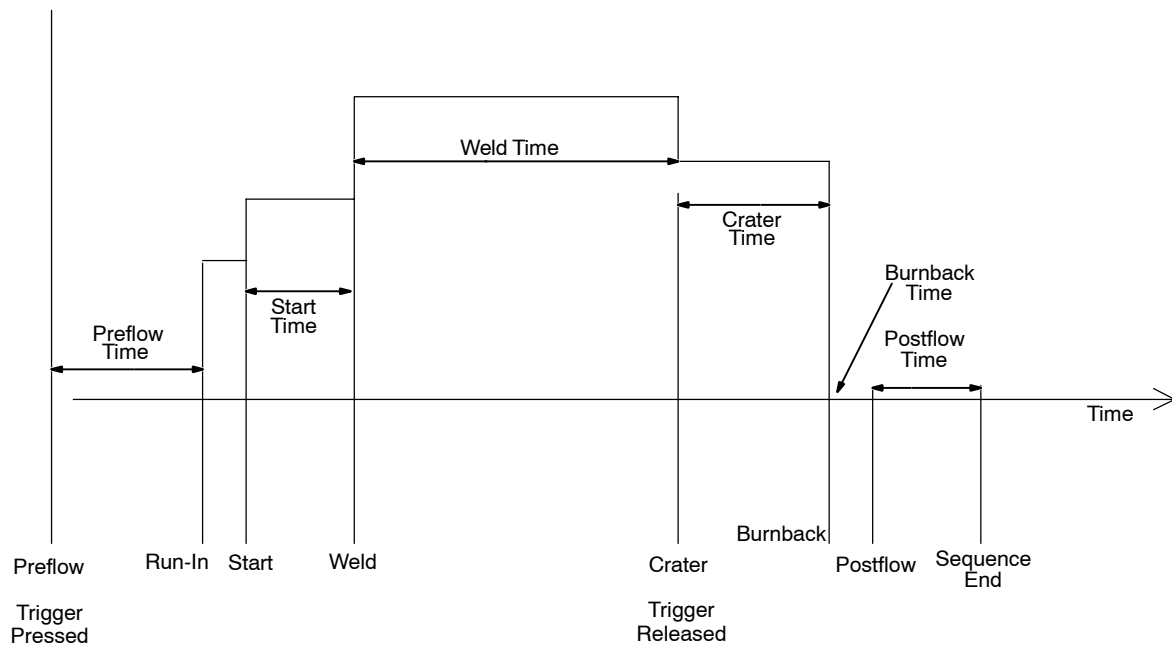

7-2. Diagnostics

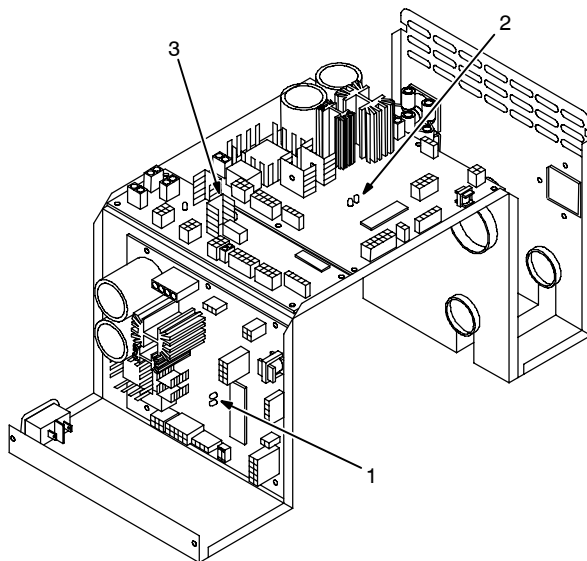

- 1 LED3 On Right Side Motor Control Board PC1
- 2 LED3 On Left Side Motor Control Board PC101
- 3 LED4 On Dual Board PC70

☞ There is a two-position DIP switch S1 located on motor control boards PC1 and PC101. These switches are factory-set in the off position and must remain in that position for the unit to operate correctly.

803 063-A

Left Side Motor Control Board PC101

ERR	ERR	ERR	ERR
COM1	TRG1	TCH1	MTR1
Indicates a communication error.	Indicates a trigger error.	Indicates a tachometer error.	Indicates a motor error.

☞ Note: The error messages are shown on the upper and lower displays to indicate specific errors. Explanations are in the text below:

Right Side Motor Control Board PC1

ERR	ERR	ERR	ERR
COM2	TRG2	TCH2	MTR2
Indicates a communication error.	Indicates a trigger error.	Indicates a tachometer error.	Indicates a motor error.

Dual Board PC70

ERR	Indicates a communication error.
COM3	

Error Indications

Error conditions are indicated by LED3 on PC1, PC101, and LED4 on PC70. To view LEDs, turn Off unit, remove wrapper, and turn unit On.

The LED blinks in a 2.5 second cycle. The number of blinks in this period indicates the type of error.

The priority of the errors is related to the number of blinks indicating the error. The more blinks, the more severe the error (motor error is top priority). A higher priority error overrides a lower one (if a motor error and a communication error existed, the light would blink four times for the motor error).

Since blink On time and blink Off time are equal in a four-blink cycle, the four-blink sequence appears as a constant blink.

- 1 blink = Communication Error
- 2 blinks = Trigger Error
- 3 blinks = Tach Error
- 4 blinks = Motor Error

- **The communication error** occurs 2.5 seconds after a loss of communication between the motor and the Front Panel board or Dual board. The user may continue to weld with this error.

- **The trigger error** occurs if the user has the trigger held for more than two minutes without striking an arc (providing current override is not enabled), or if the user holds the trigger past the postflow phase in a timed weld. This error also occurs if the trigger is held when the feeder is powered up. The error may be cleared by releasing the trigger.

- **The tach error** occurs 2 seconds after the loss of tachometer feedback. The user may continue to weld with this error. The motor speed is regulated through the monitoring of voltage and current.

- **The motor error** indicates that the motor has been drawing too much current for too long.

7-3. Diagnostics For User Defined Options

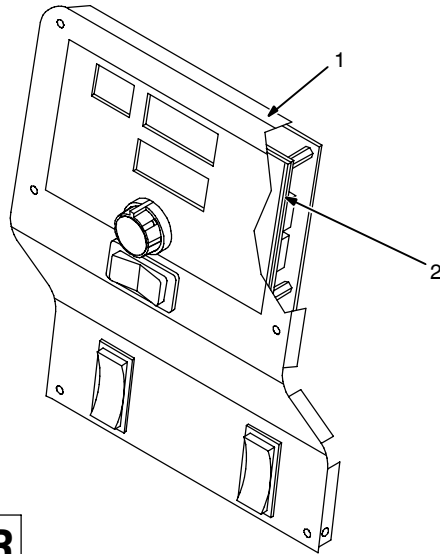

- 1 Front Panel
- 2 Front Panel Board PC20

User Defined Shutdown Error Messages (Additional hardware required for these to be functional)

If OPT1 and/or OPT2 are enabled without additional hardware setup, the following error messages will be displayed on the front panel meters. OPT1 and/or OPT2 must be disabled.

Refer to Section 5-12 for correct setup procedures.

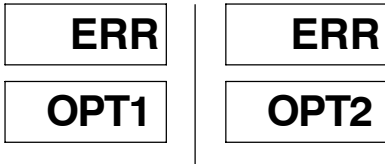

Indicates a User Defined Option Error

803 198

SECTION 8 – MAINTENANCE & TROUBLESHOOTING

8-1. Routine Maintenance

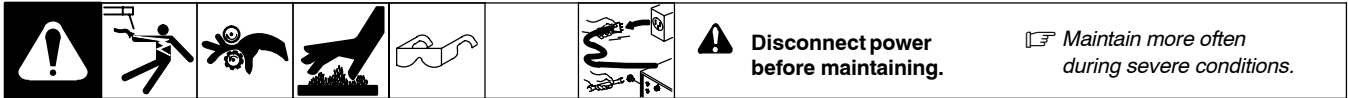

<p>3 Months</p>				
<p>Replace unreadable labels.</p>	<p>Clean and tighten weld terminals.</p>	<p>Repair or replace cracked weld cable.</p>		
<p>Replace cracked parts.</p>	<p>Check 14-pin cord.</p>	<p>Check gas hose and fittings.</p>	<p>Check gun cable.</p>	
<p>6 Months</p>				
<p>Blow out or vacuum inside. During heavy service, clean monthly.</p>	<p>Or</p>	<p>Clean drive rolls.</p>		

8-2. Troubleshooting



Trouble	Remedy
Wire feeds, shielding gas flows, but electrode wire is not energized.	Check interconnecting cord connections. If secure, check cord for continuity and repair or replace (see Sections 4-5 and 4-6).
Wire feeder is on, meter(s) do not light up, motor does not run, gas valve and welding power source contactor do not pull in.	Check and reset circuit breaker at welding power source.
Electrode wire feeding stops or feeds erratically during welding.	Check gun trigger connection. See gun Owner's Manual.
	Check gun trigger. See gun Owner's Manual.
	Readjust hub tension and drive roll pressure (see Section 4-11).
	Change to correct size drive roll (see Table 10-1).
	Clean or replace dirty or worn drive roll.
	Incorrect size or worn wire guides.
	Replace contact tip or liner. See gun Owner's Manual.
	Remove weld spatter or foreign matter from around nozzle opening.
Motor runs slowly.	Have Factory Authorized Service Agency check drive motor or motor control board PC1.
Wire does not feed until trigger is pulled, but continues to feed after trigger is released, and trigger hold is not on.	Check for correct input voltage.
Wire does not feed until trigger is pulled, but continues to feed after trigger is released, and trigger hold is not on.	Check for a short between welding gun trigger leads and weld cable. Repair short or replace welding gun.
Gas valve in feeder is rattling loudly along with possible erratic or slow wire feed speed.	Check for a short between welding gun trigger leads and weld cable. Repair short or replace welding gun.
Wire feeder power is on, displays light up, but unit is inoperative.	Check welding gun trigger leads for continuity, and repair leads or replace gun.

SECTION 9 – ELECTRICAL DIAGRAM

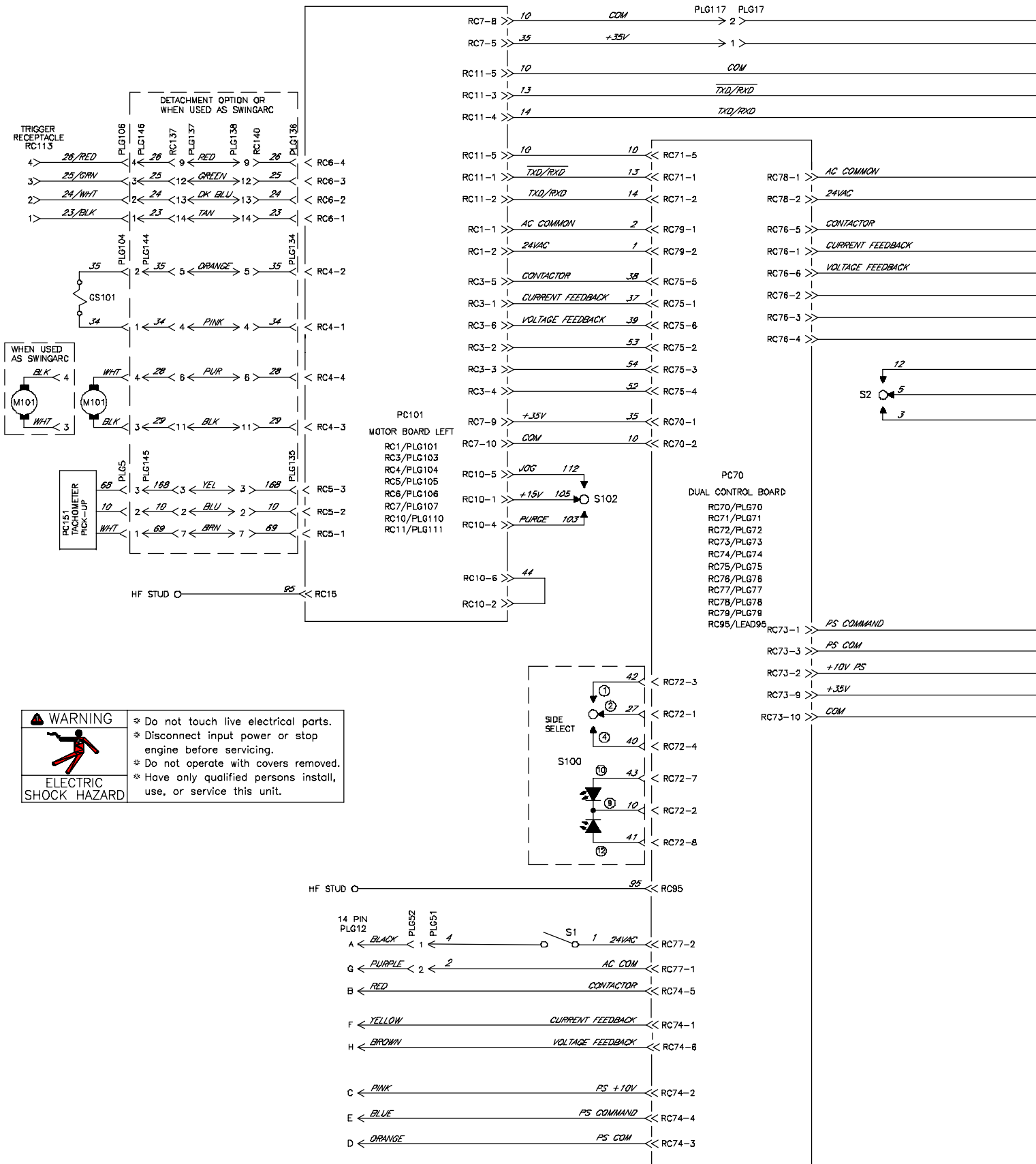
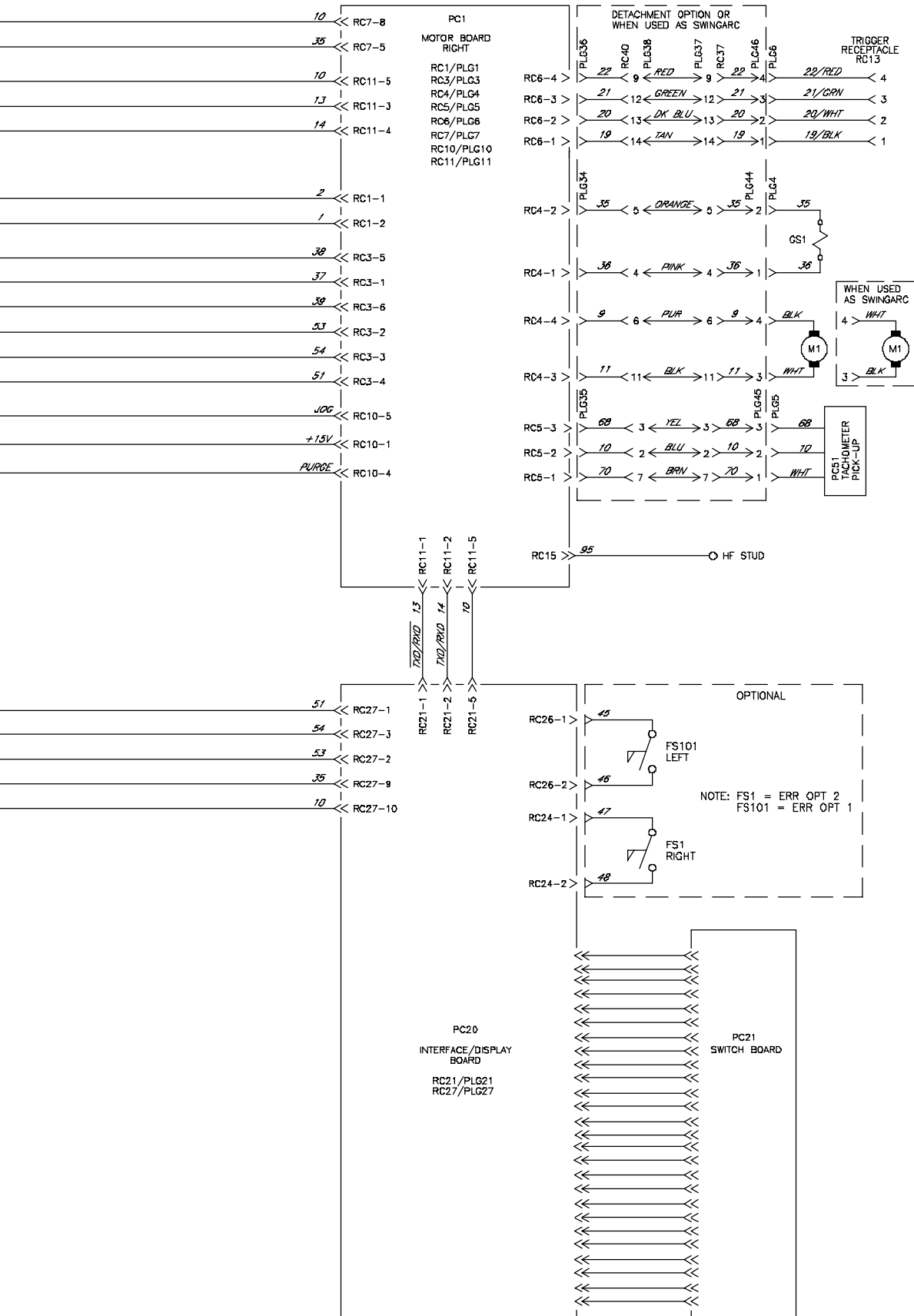



Figure 9-1. Circuit Diagram



SECTION 10 – PARTS LIST

 Hardware is common and not available unless listed.

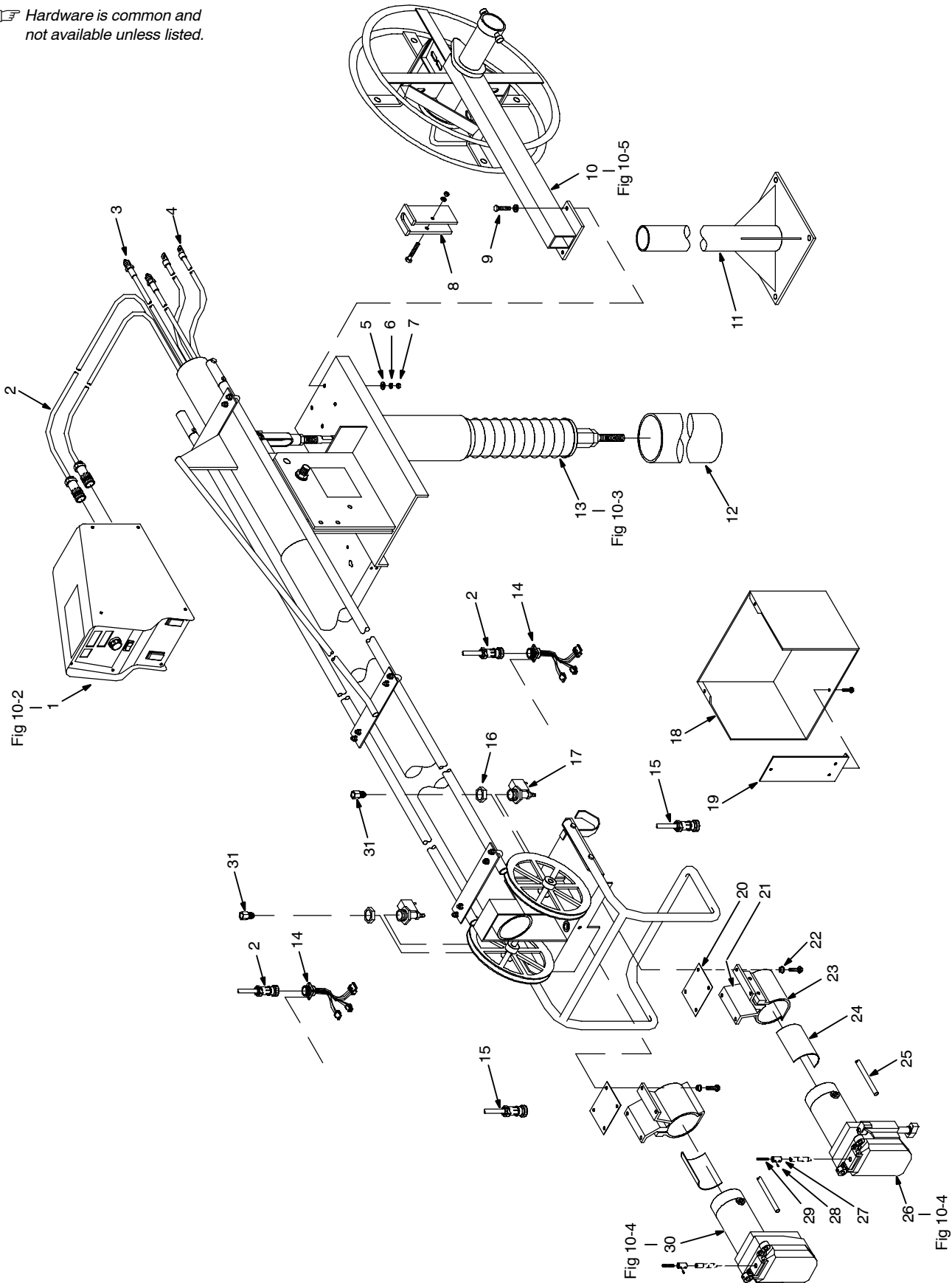

Figure 10-1. Main Assembly

803 189-C

Item No.	Dia. Mkgs.	Part No.	Description	Quantity	
				Model DS-12	DS-16

Figure 10-1. Main Assembly

1		See Note	Control Box, (Fig 10-2)	1	1
2		201 319	Cable, Interconnecting (consisting of)	2	0
2		201 320	Cable, Interconnecting (consisting of)	0	2
	PLG37,38,137,138	047 636	Connector & Pins	2	2
		079 739	Connector, Circ Clamp Str Rlf Sz 17-20 Amp 206322-2	2	2
		163 520	Cable, Port No. 18/14 8/C (order by ft)	17Ft	21Ft
3		139 600	Hose, Gas	2	0
3		139 599	Hose, Gas	0	2
4		600 324	Cable, Weld Cop Strd No. 4/0 (order by ft)	26Ft	30Ft
5		602 243	Washer, Flat Stl Std .375	8	8
6		602 213	Washer, Lock Stl Split .375	4	4
7		601 872	Nut, Stl Hex Full .375-16	4	4
8		080 947	Bracket, Spring Retaining	1	0
8		151 626	Bracket, Spring Retaining	0	1
9		132 053	Screw, Cap Stl Hexhd .375-16 X 1.500 Lg	4	4
10		Fig 10-5	Support, Hub & Reel	1	1
11		◆149 838	Pipe Post, 4ft W/Base Or	1	0
11		◆149 839	Pipe Post, 6ft W/Base	1	0
11		◆078 264	Pipe Post, 4ft W/Base Or	0	1
11		◆079 216	Pipe Post, 6ft W/Base	0	1
12		◆075 078	Pipe Post, 4ft W/O Base Or	1	1
12		◆079 217	Pipe Post, 6ft W/O Base	1	1
13		Fig 10-3	Boom Assembly	1	1
14	RC37,137	047 637	Connector & Sockets (consisting of)	2	2
	PLG45,145	131 203	Housing Plug + Pins, (service kit)	2	2
	PLG44,144	167 640	Housing Plug Pins + Skts (service kit)	2	2
	PLG46,146	115 090	Housing Plug + Pins, (service kit)	2	2
15		203 314	Cable, Trigger 20 In Boom/Detach (consisting of)	2	2
		115 094	Housing Plug+Skts,(service kit)	2	2
		080 328	Rcpt W/Skts,Free Hanging	2	2
		079 531	Conn,Circ Cpc Clamp Str Rlf Size 11 .453od	2	2
		604 571	Cable,Port No 18 4/C Type sjo nprn jkt re		2Ft
16		605 227	Nut, Nyl Hex Jam .750npst	2	2
17	GS1,101	228 035	Valve, 34VDC 1way .750-14 Thd 2mm Orf 100PSI	2	2
	PLG4,104	136 810	Housing Plug + Skts (service kit)	2	2
18		139 813	Cover, Protector Motor	1	1
19		139 816	Panel, Encl Cover	1	1
20		159 647	Insulator, Motor Clamp	2	2
21		159 646	Clamp, Motor Base	2	2
22		159 360	Insulator, Screw Machine	8	8
23		156 243	Clamp, Motor Top	2	2
24		145 639	Strip, Buna N Compressed Sheet .062 X 4.000sq	2	2
25		134 834	Hose, Sae .187 Id X .410 Od (order by ft)	3Ft	3Ft
26		208 944	Drive Assy,Wire Rh Vertical 4 Roll W/Clamp&tach (Fig 10-4)	1	1
26		◆208 945	Drive Assy,Wire Rh Vert 4 Roll Hi-speed W/Cl&tach (Fig 10-4)	1	1
27		157 295	Guide, Monocoil	2	2
28		604 612	Screw, Set Stl Sch 8-32 X .125 Cup Point	4	4
29		082 050	Liner, Monocoil Inlet Wire	2	2
30		201 776	Drive Assy,Wire L Vertical 4 Roll W/Clamp&tach (Fig 10-4)	1	1
30		◆201 777	Drive Assy,Wire L Vert 4 Roll Hi-speed W/Cl&tach (Fig 10-4)	1	1
		149 322	Clamp, Hose .405-.485clp	4	4
31		211 989	Fitting, W/Screen	2	2

◆ OPTIONAL

Note: When ordering Control Box contact factory service department for proper number.

To maintain the factory original performance of your equipment, use only Manufacturer's Suggested Replacement Parts. Model and serial number required when ordering parts from your local distributor.

 Hardware is common and not available unless listed.

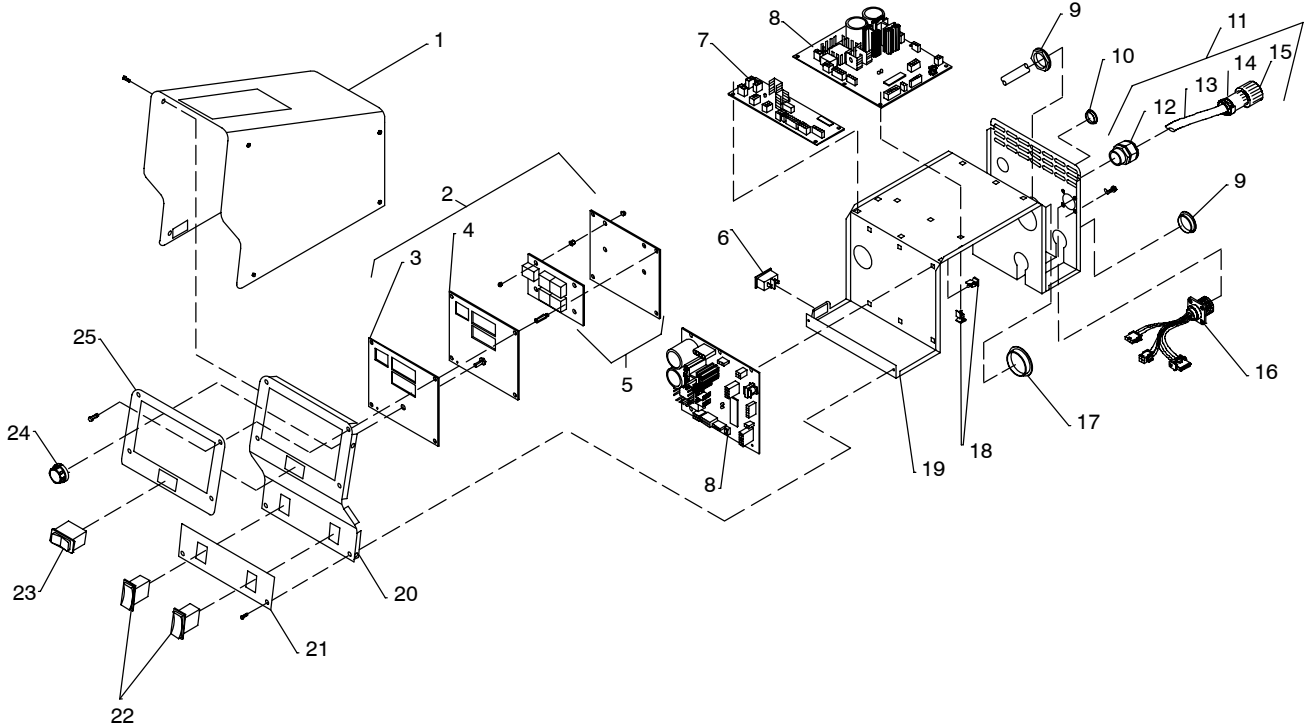

803 200

Figure 10-2. Control Box

Item No.	Dia. Mkgs.	Part No.	Description	Quantity
----------	------------	----------	-------------	----------

Figure 10-2. Control Box (Figure 10-1 Item 1)

...	1	204 722	.. Wrapper, Feeder	1	
...		134 464	.. Label,Warning General Precautionary Static&wire Fe	1	
...	2	206 764	.. Panel, PC Card Front (consisting of)	1	
...	3	200 153	... Overlay, Front Panel	1	
...	4	PC21	200 693	.. Circuit Card Assy,Switches	1
...	5	PC20	210 683	.. Panel, Pc Card Display W/Program	1
...	6	S1	111 997	.. Switch, Rocker Spst 10A 250vac On-Off Visi Red Rock	1
...	7	PC70	220 903	.. Circuit Card Assy, Dual W/Program	1
...	8	PC1,101	217 898	.. Circuit Card Assy, Motor Control W/Program	2
...	9		030 170	.. Bushing,Snap-in Nyl .750 Id X 1.000 Mtg Hole	1
...	10		000 527	.. Blank, Snap-in Nyl .875 Mtg Hole Black	1
...	10		047 838	.. Blank,Snap-in Nyl 1.000 Mtg Hole Black	1
...	11		201 228	.. Cable, Power 16.5ft 8/c 2-14ga 6-18ga (consisting of)	1
...	12		139 041	... Strain Relief	1
...	13		163 519	... Cable, Port	16.5 Ft
...	14		079 739	... Conn, circ cpc clamp str rlf	1
...	15	PLG12	141 162	... Housing Plug+Pins, (service kit)	1
...		PLG52	174 823	... Housing Plug Pins+Skts, (service kit)	1
...		PLG74	115 093	... Housing Plug+Skts, (service kit)	1
...	16	RC40,140	047 637	.. Housing Rcpt+Skts,(service kit)	2
...		PLG34,134	136 810	.. Housing Plug+Skts, (service kit)	2
...		PLG35,135	131 204	.. Housing Plug+Skts, (service kit)	2
...		PLG36,136	115 094	.. Housing Plug+Skts, (service kit)	2
...	17		010 494	.. Bushing, Snap-in Nyl 1.375 Id X 1.750 Mtg Hole	2

Item No.	Dia. Mkgs.	Part No.	Description	Quantity
----------	------------	----------	-------------	----------

Figure 10-2. Control Box (Continued)

... 18		134 201	.. Stand-Off Support, PC Card .312/.375w/Post&lock .43	17
... 19		204 721	.. Enclosure, Control	1
... 20		206 765	.. Panel, Front	1
... 21		206 771	.. Nameplate, Miller Lower	1
... 22	S2,102	200 295	.. Switch, Rocker Spdt 15A 12V (On)-Off-(On)	2
... 23	S100	201 641	.. Switch, Rocker Spdt 15A 12V (On)-Off-(On) W/leds	1
... 24		213 134	.. Knob, Encoder 1.670 Dia x .250 Id Push On W/Spring	1
... 25		207 745	.. Nameplate, Miller Switch	1

	Dia. Mkgs.	Part No.	Description	Quantity
--	------------	----------	-------------	----------

Harness Connectors/Receptacles

.....	PLG6,106	115 094	.. Housing Plug+Skts, (service kit)	1
.....	PLG10,110	130 203	.. Housing Plug+Skts, (service kit)	1
.....	PLG72	115 092	.. Housing Plug+Skts, (service kit)	1
.....	PLG4,104	136 810	.. Housing Plug+Skts, (service kit)	1
....	PLG11, 21,71,111	131 055	.. Housing Rcpt+Skts, (service kit)	1
..	PLG1,77,78,79,101	202 592	.. Housing Plug+Skts, (service kit)	1
.....	PLG3,75,76,103	115 093	.. Housing Plug+Skts, (service kit)	1
.....	PLG51	174 824	.. Housing Plug Pins+Skts, (service kit)	1
.....	PLG7,27,67,107	115 091	.. Housing Plug+Skts, (service kit)	1
.....	PLG73	148 439	.. Housing Plug Pins+Skts, (service kit)	1
.....	PLG17,70	158 719	.. Housing Plug+Skts, (service kit)	1
.....	PLG117	165 404	.. Housing Rcpt+Skts, (service kit)	1

 Hardware is common and not available unless listed.

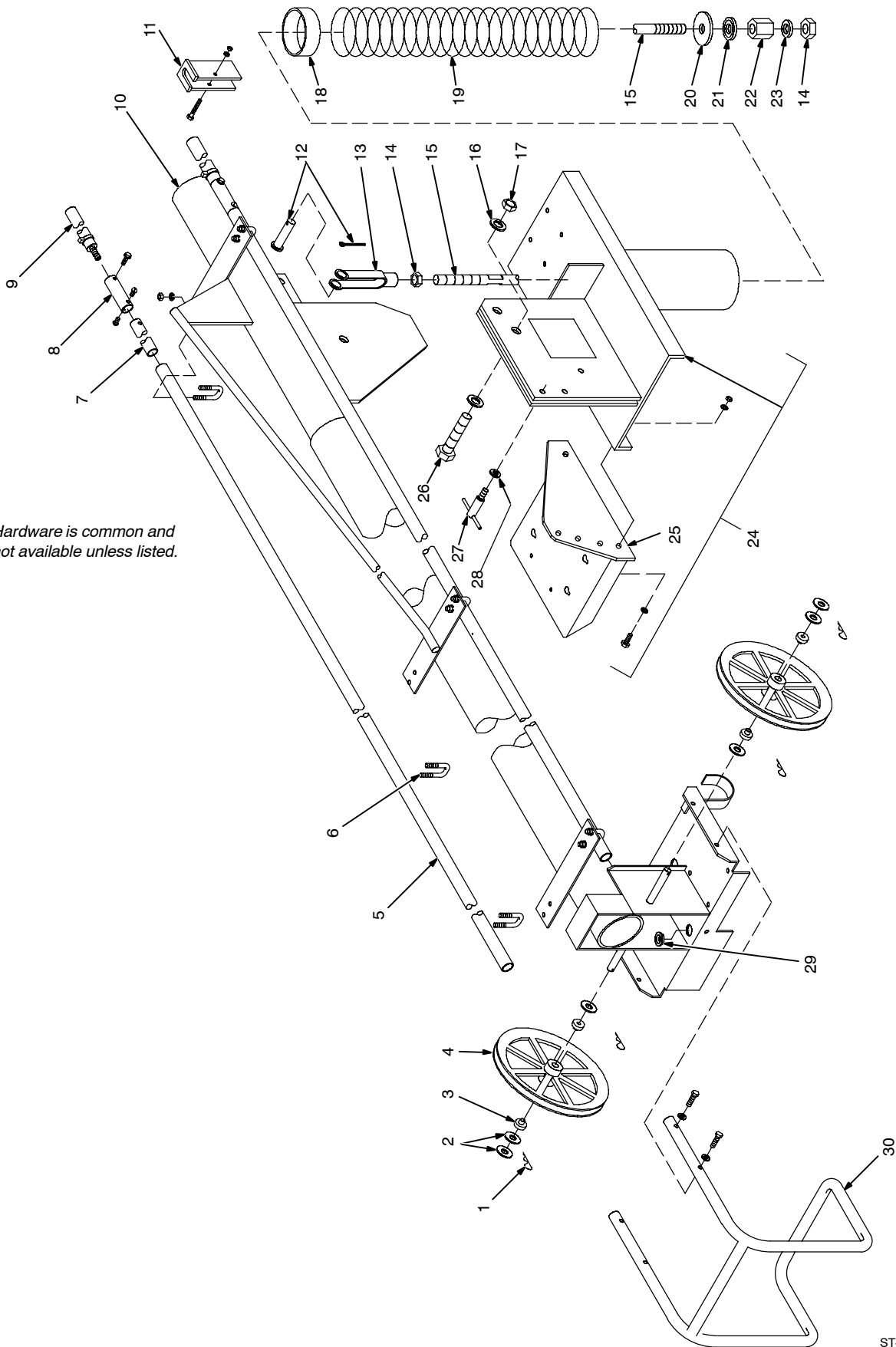

Figure 10-3. Boom Assembly

ST-142 306-H

Item No.	Part No.	Description	Quantity	
			Model DS-12	Model DS-16

Figure 10-3. Boom Assembly (Figure 10-1 Item 13)

1	010 313	Pin, Cotter Hair .072 X 1.437	4	4
2	010 910	Washer, Flat Stl Sae .375	6	6
3	079 622	Washer, Shld .381 Id X .750 Od	2	2
4	079 621	Pulley, V Sgl Grv 7.750dia X 8.000p X .625 Bore	2	2
5	079 667	Pipe, Plstc .500 X 133.750	2	0
5	080 812	Pipe, Plstc .500 X 181.750	0	2
6	079 632	Bolt, U Stl .250-20 X .875 Wide X 1.375 Deep	8	10
7	079 665	Guide, Wire	2	0
7	080 811	Guide, Wire	0	2
8	079 664	Guide, Wire Inlet	2	2
9	139 633	Liner, Monocoil 3/32-1/8 Wire X 15.687	2	2
10	159 999	Boom, Dual	1	0
10	160 513	Boom, Dual	0	1
11	080 947	Bracket, Spring Retaining	1	0
11	151 626	Bracket, Spring Retaining	0	1
12	073 742	Pin, Clevis .750 Od X 2.156 Lg	1	1
13	073 741	Clevis, .812 Yoke 6.062 Lg .750-16Thd	1	1
14	079 029	Nut, Stl Hex Full Fnsh .750-16	2	2
15	075 462	Shaft, Boom Counterbalance	1	1
16	602 250	Washer, Flat Stl Sae .750	2	2
17	079 020	Nut, Stl Hex Elastic Stop .750-16	1	1
18	155 335	Pipe, Blk 3.000 X .875	0	1
19	149 858	Spring, Cprsn 3.750 Od X .625 Wire X 36.000	1	0
19	151 625	Spring, Cprsn 3.750 Od X .640 Wire X 36.000	0	1
20	150 258	Retainer, Spring	1	1
21	024 605	Bearing, Ball Thr Sgl Row .750 X 1.625 X .625	1	1
22	075 101	Nut, Stl Hex Special .750-16 X 1.250	1	1
23	079 030	Washer, Lock Stl Ext Tooth .750	1	1
24	+174 754	Base, Swivel Boom (consisting of)	1	1
	080 157	Fitting, Grease 1/8npt	1	1
25	174 688	Bracket, Mtg Control Tilt	1	1
	142 804	Label, Swingarc Caution Heavy Spring	1	1
	134 327	Label, Warning General Precautionary	1	1
26	073 666	Bolt, Mach Stl Hexhd .750-16 X 2.750	1	1
27	047 224	Knob, T-bar .500-13Thd	1	1
28	602 246	Washer, Flat Stl Std .500	1	1
29	010 493	Bushing, Snap-in Nyl .625 Id X .875mtg Hole	1	1
30	139 818	Guard, Motor Protector	1	1

+When ordering a component originally displaying a precautionary label, the label should also be ordered.

To maintain the factory original performance of your equipment, use only Manufacturer's Suggested Replacement Parts. Model and serial number required when ordering parts from your local distributor.

☞ Hardware is common and not available unless listed.

See Table 10-1 For Drive Roll & Wire Guide Kits

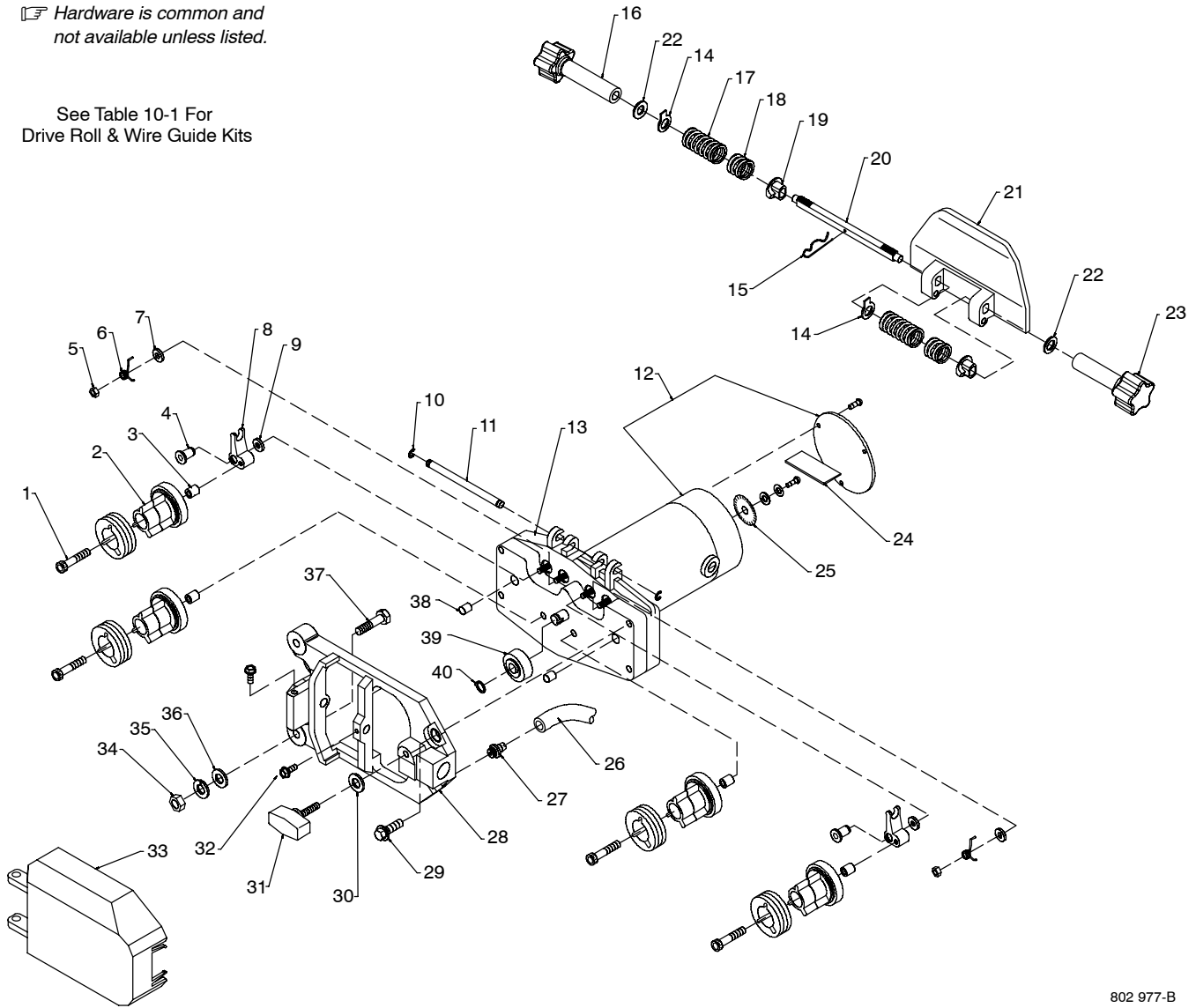

802 977-B

Figure 10-4. Drive Assembly, Wire

Item No.	Dia. Mkgs.	Part No.	Description	Quantity	
				Model DS-12	Model DS-16

Figure 10-4. Drive Assembly, Wire (Figure 10-1 Items 26 and 30)

...	1	010 668	.. Screw, Cap Stl Sch .250-20 X 1.500	4	4
...	2	172 075	.. Carrier, Drive Roll W/Components 24 Pitch	4	4
...	3	149 962	.. Spacer, Carrier Drive Roll	4	4
...	4	149 486	.. Pin, Rotation Arm Rocker	2	2
...	5	163 282	.. Nut, .250-28 Stl	2	2
...	6	165 798	.. Spring, Pressure Arm Retaining	2	2
...	7	165 799	.. Washer, Flat .257 Id Stl	2	2
...	8	132 750	.. Arm, Pressure	2	2
...	9	150 520	.. Spacer, Rotation Pin	2	2
...	10	133 493	.. Ring, Retaining Ext .250 Shaft X .025thk	2	2
...	11	133 350	.. Pin, Hinge	1	1
...	12	M1,101 201 230	.. Motor, Gear 1/8hp 24vdc Standard Speed	1	1
...	12	M1,101 201 231	.. Motor, Gear 1/8hp 24vdc High Speed	0	1
...		153 491	... Kit, Brush Replacement (consisting of)	1	1
...		153 492	... Cap, Brush	2	2
...		*153 493	... Brush, Carbon	2	2

Item No.	Dia. Mkgs.	Part No.	Description	Quantity	
				Model	
				DS-12	DS-16

Figure 10-4. Drive Assembly, Wire (continued)

		184 136	Kit, Brush Holder	1	1
13		155 098	Kit, Cover Motor Gearbox (consisting of)	1	1
		153 550	Cover, Motor Gearbox (consisting of)	1	1
		155 099	Gasket, Cover	1	1
		155 100	Screw, Cover	5	5
		154 031	Spacer, Locating	2	2
		133 493	Ring, Rtnng Ext .250 Shaft Grv X .025Thk	1	1
		203 642	Pressure Arm,R & Vert L 4 Roll (consisting of)	1	1
		203 631	Pressure Arm,S/L & Vert S/R 4 Roll (consisting of)	1	1
14		203 461	Washer, Flat Indicator Spring Tension	2	2
15		182 415	Pin, Cotter Hair	1	1
16		203 640	Knob, W/Extension Short Pressure Arm	1	1
17		182 156	Spring, Cprsn	2	2
18		182 155	Spring	2	2
19		132 746	Bushing, Spring	2	2
20		203 633	Shaft, Spring	1	1
21		203 632	Carrier, Shaft	1	1
22		133 739	Washer, Flat Buna .375 Id X .625 Od X .062Thk	2	2
23		203 637	Knob, W/Extension Long Pressure Arm	1	1
24	PC51,151	201 225	Circuit Card, Digital Tach (consisting of)	1	1
	PLG5	131 204	Connector & Sockets	1	1
		604 311	Grommet, Rbr .250 Id X .375Mtg Hole	1	1
25		132 611	Optical Encoder Disc	1	1
		603 115	Weather Stripping, Adh .125 X .375	1	1
26		134 834	Hose, Sae .187 Id X .410 Od (order by ft)	2	Ft
27		149 959	Fitting, Brs Barbed M 3/16Tbg X .312-24	1	1
28		179 265	Adapter, Gun/Feeder Lh	1	1
28		179 264	Adapter, Gun/Feeder Rh	1	1
29		108 940	Screw, Cap Stl Hexwhd .250-20 X .750	4	4
30		604 538	Washer, Flat Stl Sae .312	1	1
31		151 437	Knob, Plstc T 1.125 Lg X .312-18 X 1.500 Bar	1	1
32		151 290	Screw, Hexwhd-Slt Stl Slffmg 10-32 X .500	2	2
33		179 277	Cover, Drive Roll (consisting of)	1	1
		196 956	Label, Warning Electric Shock And Pinch	1	1
34		601 872	Nut, Stl Hex Full .375-16	1	1
35		602 213	Washer, Lock Stl Split .375	1	1
36		602 243	Washer, Flat Stl .375	1	1
37		601 966	Screw, Cap Stl Hexhd .375-16 X 1.250	1	1
38		167 387	Spacer, Locating	2	2
39		168 825	Drive, Pinion 40t 24p .376 Bore	1	1
40		133 308	Ring, Retaining Ext .375 Shaft X .025Thk	1	1

*Recommended Spare Parts.

To maintain the factory original performance of your equipment, use only Manufacturer's Suggested Replacement Parts. Model and serial number required when ordering parts from your local distributor.

Hardware is common and not available unless listed.

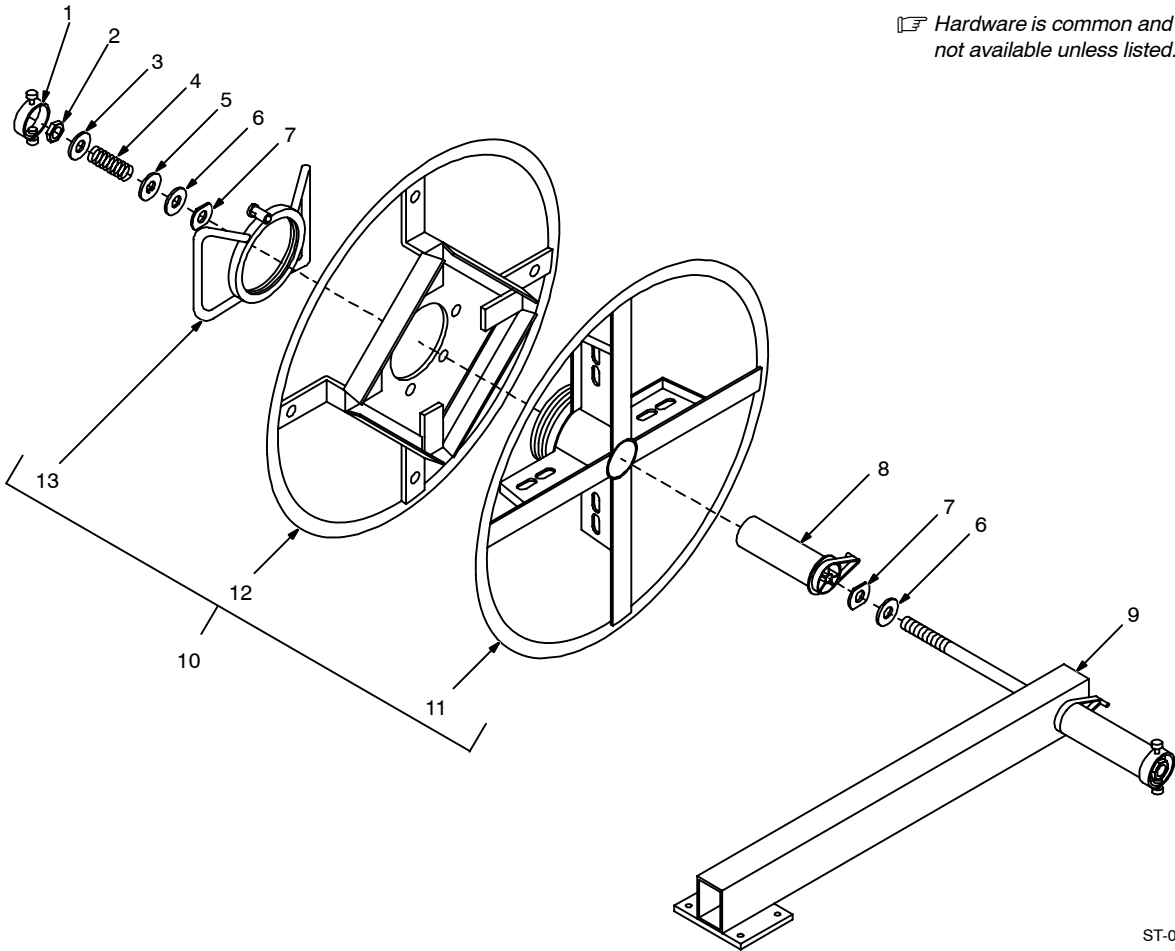

ST-081 760-C

Figure 10-5. Support, Hub & Reel

Item No.	Part No.	Description	Quantity
Figure 10-5. Support, Hub and Reel (Figure 10-1 Item 10)			
...	1	058 427 .. Ring, Retaining Spool	2
...	2	136 684 .. Nut, Stl Sflkg Hex Reg .625-11 W/Nyl Insert	2
...	3	605 941 .. Washer, Flat Stl .640 Id X 1.000 Od X 14ga Thk	2
...	4	010 233 .. Spring, Cprsn .970 Od X .120 Wire X 1.250	2
...	5	057 971 .. Washer, Flat Stl Keyed 1.500Dia X .125Thk	2
...	6	010 191 .. Washer, Fbr .656 Id X 1.500 Od X .125Thk	4
...	7	058 628 .. Washer, Brake Stl	4
...	8	058 428 .. Hub, Spool	2
...	9	080 393 .. Support, Reel	1
...	10	◆ 108 008 .. Reel, Wire 60 Lb (consisting of)	2
...	11	124 900 .. Support, Reel Spool	1
...	12	+168 104 .. Retainer, Spool Support (consisting of)	1
...		166 594 .. Label, Caution Falling Wire Reel Can Cause Damage	1
...	13	168 103 .. Nut, Spanner Retaining	1

◆ OPTIONAL

+When ordering a component originally displaying a precautionary label, the label should also be ordered.

To maintain the factory original performance of your equipment, use only Manufacturer's Suggested Replacement Parts. Model and serial number required when ordering parts from your local distributor.

Table 10-1. Drive Roll and Wire Guide Kits

Wire Size		Inlet Guide	Intermediate Guide	V-GROOVE		U-GROOVE		VK-GROOVE		UC-GROOVE	
Fraction	Metric			4 Roll Kit	Drive Roll	4 Roll Kit	Drive Roll	4 Roll Kit	Drive Roll	4 Roll Kit	Drive Roll
.023-.025 in.	0.6 mm	150 993	149 518	151 024	087 130						
.030 in.	0.8 mm	150 993	149 518	151 025	053 695						
.035 in.	0.9 mm	150 993	149 518	151 026	053 700	151 036	072 000	151 052	132 958		
.040 in.	1.0 mm	150 993	149 518	161 189	053 696						
.045 in.	1.1/1.2 mm	150 994	149 519	151 027	053 697	151 037	053 701	151 053	132 957	151 070	083 489
.052 in.	1.3/1.4 mm	150 994	149 519	151 028	053 698	151 038	053 702	151 054	132 956	151 071	083 490
1/16 in. (.062 in.)	1.6 mm	150 995	149 520	151 029	053 699	151 039	053 706	151 055	132 955	151 072	053 708
.068-.072 in.	1.8 mm	150 995	149 520					151 056	132 959		
5/64 in. (.079 in.)	2.0 mm	150 995	149 520			151 040	053 704	151 057	132 960	151 073	053 710
3/32 in. (.094 in.)	2.4 mm	150 996	149 521			151 041	053 703	151 058	132 961	151 074	053 709
7/64 in. (.110 in.)	2.8 mm	150 996	149 521			151 042	053 705	151 059	132 962	151 075	053 711
1/8 in. (.125 in.)	3.2 mm	150 997	149 522			151 043	053 707	151 060	132 963	151 076	053 712

Each Kit Contains An Inlet Guide, Intermediate Guide, And 045 233 Antiwear Guide With 604 612 Setscrew 8-32 x .125, Along With 4 Drive Rolls.
2 Kits Required For Dual Models.

S-0549-D

TRUE BLUE[®]

WARRANTY

Effective January 1, 2007

(Equipment with a serial number preface of "LH" or newer)

This limited warranty supersedes all previous Miller warranties and is exclusive with no other guarantees or warranties expressed or implied.

LIMITED WARRANTY – Subject to the terms and conditions below, Miller Electric Mfg. Co., Appleton, Wisconsin, warrants to its original retail purchaser that new Miller equipment sold after the effective date of this limited warranty is free of defects in material and workmanship at the time it is shipped by Miller. THIS WARRANTY IS EXPRESSLY IN LIEU OF ALL OTHER WARRANTIES, EXPRESS OR IMPLIED, INCLUDING THE WARRANTIES OF MERCHANTABILITY AND FITNESS.

Within the warranty periods listed below, Miller will repair or replace any warranted parts or components that fail due to such defects in material or workmanship. Miller must be notified in writing within thirty (30) days of such defect or failure, at which time Miller will provide instructions on the warranty claim procedures to be followed.

Miller shall honor warranty claims on warranted equipment listed below in the event of such a failure within the warranty time periods. All warranty time periods start on the delivery date of the equipment to the original end-user purchaser, and not to exceed one year after the equipment is shipped to a North American distributor or eighteen months after the equipment is shipped to an International distributor.

1. 5 Years Parts — 3 Years Labor
 - * Original main power rectifiers
2. 3 Years — Parts and Labor
 - * Transformer/Rectifier Power Sources
 - * Plasma Arc Cutting Power Sources
 - * Process Controllers
 - * Semi-Automatic and Automatic Wire Feeders
 - * Inverter Power Sources (Unless Otherwise Stated)
 - * Water Coolant Systems (Integrated)
 - * Intellitig
 - * Engine Driven Welding Generators
(NOTE: Engines are warranted separately by the engine manufacturer.)
3. 1 Year — Parts and Labor Unless Specified
 - * Motor Driven Guns (w/exception of Spoolmate Spoolguns)
 - * Positioners and Controllers
 - * Automatic Motion Devices
 - * RFCS Foot Controls
 - * Induction Heating Power Sources, Coolers, and Electronic Controls/Recorders
 - * Water Coolant Systems (Non-Integrated)
 - * Flowgauge and Flowmeter Regulators (No Labor)
 - * HF Units
 - * Grids
 - * Spot Welders
 - * Load Banks
 - * Arc Stud Power Sources & Arc Stud Guns
 - * Racks
 - * Running Gear/Trailers
 - * Plasma Cutting Torches (except APT & SAF Models)
 - * Field Options
(NOTE: Field options are covered under True Blue[®] for the remaining warranty period of the product they are installed in, or for a minimum of one year — whichever is greater.)
 - * Bernard-Branded Mig Guns (No Labor)
 - * Weldcraft-Branded TIG Torches (No Labor)
 - * Subarc Wire Drive Assemblies
4. 6 Months — Batteries
5. 90 Days — Parts
 - * MIG Guns/TIG Torches and Subarc (SAW) Guns

- * Induction Heating Coils and Blankets, Cables, and Non-Electronic Controls
- * APT & SAF Model Plasma Cutting Torches
- * Remote Controls
- * Accessory (Kits)
- * Replacement Parts (No labor)
- * Spoolmate Spoolguns
- * Canvas Covers

Miller's True Blue[®] Limited Warranty shall not apply to:

1. **Consumable components; such as contact tips, cutting nozzles, contactors, brushes, slip rings, relays or parts that fail due to normal wear. (Exception: brushes, slip rings, and relays are covered on Bobcat, Trailblazer, and Legend models.)**
2. Items furnished by Miller, but manufactured by others, such as engines or trade accessories. These items are covered by the manufacturer's warranty, if any.
3. Equipment that has been modified by any party other than Miller, or equipment that has been improperly installed, improperly operated or misused based upon industry standards, or equipment which has not had reasonable and necessary maintenance, or equipment which has been used for operation outside of the specifications for the equipment.

MILLER PRODUCTS ARE INTENDED FOR PURCHASE AND USE BY COMMERCIAL/INDUSTRIAL USERS AND PERSONS TRAINED AND EXPERIENCED IN THE USE AND MAINTENANCE OF WELDING EQUIPMENT.

In the event of a warranty claim covered by this warranty, the exclusive remedies shall be, at Miller's option: (1) repair; or (2) replacement; or, where authorized in writing by Miller in appropriate cases, (3) the reasonable cost of repair or replacement at an authorized Miller service station; or (4) payment of or credit for the purchase price (less reasonable depreciation based upon actual use) upon return of the goods at customer's risk and expense. Miller's option of repair or replacement will be F.O.B., Factory at Appleton, Wisconsin, or F.O.B. at a Miller authorized service facility as determined by Miller. Therefore no compensation or reimbursement for transportation costs of any kind will be allowed.

TO THE EXTENT PERMITTED BY LAW, THE REMEDIES PROVIDED HEREIN ARE THE SOLE AND EXCLUSIVE REMEDIES. IN NO EVENT SHALL MILLER BE LIABLE FOR DIRECT, INDIRECT, SPECIAL, INCIDENTAL OR CONSEQUENTIAL DAMAGES (INCLUDING LOSS OF PROFIT), WHETHER BASED ON CONTRACT, TORT OR ANY OTHER LEGAL THEORY.

ANY EXPRESS WARRANTY NOT PROVIDED HEREIN AND ANY IMPLIED WARRANTY, GUARANTY OR REPRESENTATION AS TO PERFORMANCE, AND ANY REMEDY FOR BREACH OF CONTRACT TORT OR ANY OTHER LEGAL THEORY WHICH, BUT FOR THIS PROVISION, MIGHT ARISE BY IMPLICATION, OPERATION OF LAW, CUSTOM OF TRADE OR COURSE OF DEALING, INCLUDING ANY IMPLIED WARRANTY OF MERCHANTABILITY OR FITNESS FOR PARTICULAR PURPOSE, WITH RESPECT TO ANY AND ALL EQUIPMENT FURNISHED BY MILLER IS EXCLUDED AND DISCLAIMED BY MILLER.

Some states in the U.S.A. do not allow limitations of how long an implied warranty lasts, or the exclusion of incidental, indirect, special or consequential damages, so the above limitation or exclusion may not apply to you. This warranty provides specific legal rights, and other rights may be available, but may vary from state to state.

In Canada, legislation in some provinces provides for certain additional warranties or remedies other than as stated herein, and to the extent that they may not be waived, the limitations and exclusions set out above may not apply. This Limited Warranty provides specific legal rights, and other rights may be available, but may vary from province to province.

miller_warr 2007-01

Warranty Questions?

Call
1-800-4-A-MILLER
for your local
Miller distributor.

Your distributor also gives
you ...

Service

You always get the fast,
reliable response you
need. Most replacement
parts can be in your
hands in 24 hours.

Support

Need fast answers to the
tough welding questions?
Contact your distributor.
The expertise of the
distributor and Miller is
there to help you, every
step of the way.





Owner's Record

Please complete and retain with your personal records.

Model Name

Serial/Style Number

Purchase Date

(Date which equipment was delivered to original customer.)

Distributor

Address

City

State

Zip



For Service

Contact a DISTRIBUTOR or SERVICE AGENCY near you.

Always provide Model Name and Serial/Style Number.

Contact your Distributor for:

Welding Supplies and Consumables

Options and Accessories

Personal Safety Equipment

Service and Repair

Replacement Parts

Training (Schools, Videos, Books)

Technical Manuals (Servicing Information and Parts)

Circuit Diagrams

Welding Process Handbooks

To locate a Distributor or Service Agency visit www.millerwelds.com or call 1-800-4-A-Miller

Contact the Delivering Carrier to:

File a claim for loss or damage during shipment.

For assistance in filing or settling claims, contact your distributor and/or equipment manufacturer's Transportation Department.

Miller Electric Mfg. Co.

An Illinois Tool Works Company
1635 West Spencer Street
Appleton, WI 54914 USA

International Headquarters—USA

USA Phone: 920-735-4505 Auto-Attended
USA & Canada FAX: 920-735-4134
International FAX: 920-735-4125

European Headquarters – United Kingdom

Phone: 44 (0) 1204-593493
FAX: 44 (0) 1204-598066

www.MillerWelds.com

