

XEPS103 Space-Saving Powerline Network Extender

Start Here

These instructions explain how to add an XEPS103 Space-Saving Powerline Network Extender to your existing network. To do this, you complete these two simple steps:

- Connect the XEPS103 Powerline Extender to your router.
- Connect one or more XE103 Wall-Plugged Ethernet Adapters to form a PowerLine network.

How the XEPS103 Powerline Extender Fits in Your Network

After you install the XEPS103 Powerline Extender and XE103 or other HomePlug-compatible Ethernet Adapters, your network will combine these two elements:

- An Ethernet portion where the devices are connected with cables.
- A PowerLine portion where the devices are connected over your electrical power wires.

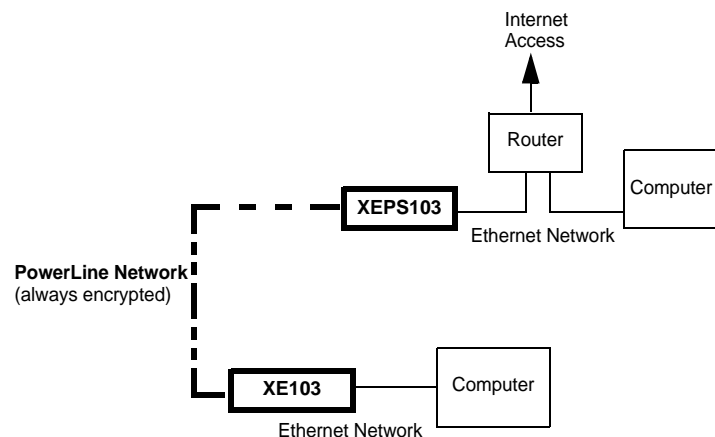

The encryption of the information you send over the PowerLine helps keep it secure. This security feature is especially relevant in settings like apartment buildings.

Prepare to Install Your XEPS103 Powerline Extender

The XEPS103 is designed for easy installation. Check that these minimum requirements are met.



- Your router uses a 12V 1A power adapter. This includes, but is not limited to, the following Netgear router and switch models:
 - FVS318
 - GS105, GS605, GS608
 - WG102
 - WGPS606
 - KWGR614, WGR614, WGT624, WGT624SC, WGTB511B
 - WNR834M, WNR834B
 - WPN824, WPNT834

If in doubt, check the label on your router's power adapter.

- Your Ethernet network is set up and an Ethernet LAN port is available on your router.

XEPS103 Status Lights

The XEPS103 Powerline Extender has status lights on the front, as described in the following table.

Status Lights on Front Panel	
	Power (color green): <ul style="list-style-type: none"> • Solid green when electrical power is on. • Off when there is no electrical power.
	Ethernet (color green): <ul style="list-style-type: none"> • Solid on when the Ethernet port is linked but there is no activity. • Blinks on when there is traffic on the Ethernet port. • Off when no link is detected.
	HomePlug—PowerLine network status (color blue): <ul style="list-style-type: none"> • Solid on when connected to a PowerLine network. • Blinks off when PowerLine data is being transmitted or received. • Off when no other compatible PowerLine devices using the same PowerLine password are found.

XEPS103 Default Settings

Feature	Setting
XEPS103 Device Password	The password for each device is printed on a label attached to the back of the device. The password for the individual devices is required if you want to set the PowerLine password for all PowerLine devices in one operation.
PowerLine Password	HomePlug ^a You can change this password to prevent unauthorized access to your PowerLine network. ^b

- This is the same default as the NETGEAR XE102, WGX102, XE103, and XE104 PowerLine products.
- You get the full bandwidth of the XEPS103 when you use it with other high-bandwidth PowerLine devices like the XE103. Giving the units their own password will put them on their own logical network, even though they share the same power wires as other PowerLine devices. Refer to the user guide on your CD for more information on configuring the PowerLine password.

Use the following procedure to set up your XEPS103 Powerline Extender.

Install the XEPS103 Powerline Extender

1. Ensure that other PowerLine units are plugged into AC power outlets and connected to computers.
2. Connect the XEPS103 to your network, as follows:
 - a. Disconnect your router from its power adapter.
 - b. Plug the gray dual output cable attached to the XEPS103 Powerline Extender into a LAN port and power inlet on your router.

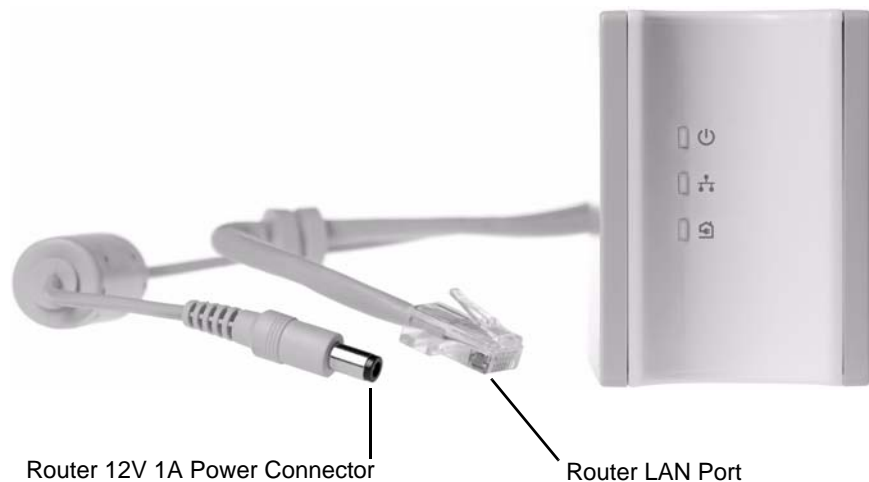

- c. Plug the XEPS103 into an electrical outlet. Take care that the electrical outlet is not controlled by a wall switch so as to avoid someone unknowingly turning off the power to the outlet. Check that the XEPS103 power light turns on.

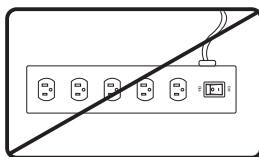

Warning: Do not connect the XEPS103 to a power strip, extension cord, or surge protector as this may prevent it from working properly or degrade the network performance.



201-11023-01

February 15, 2007

Warning: Do not tie or twist the XEPS103 power cord with the dual output cable, or any other Ethernet cable, as this may degrade the network performance.

- d. When the router indicates that the LAN port connected to the XEPS103 Powerline Extender is linked and active, check that the Ethernet and PowerLine status LEDs on the XEPS103 are also on and blinking. Refer to the table on the preceding page for a detailed explanation of the LED behavior.

This completes the PowerLine installation.

Once the PowerLine network is working, you can change the PowerLine network password using the encryption utility on the CD. Refer to the *XEPS103 Space-Saving Powerline Network Extender Installation Guide* for details.

Troubleshooting Tips

Here are some tips for correcting simple problems that could prevent you from connecting to the Internet or connecting to the XEPS103.

- **Check the green power light on the XEPS103.**
If the Power light is off, make sure that power is supplied to the electrical outlet, and the PowerLine device is not plugged into an extension cord, power strip, or surge protector.
- **Check the green data traffic light on the XEPS103.**
If this light is not blinking there is no data traffic. Make sure that your router and modem are switched on. Make sure that the computer connected directly to the router can access the Internet.
- **Check the blue HomePlug (PowerLine network status) light on the XEPS103.**
If this light is off, the PowerLine devices cannot find each other. Make sure that the XEPS103 and other PowerLine devices are plugged into outlets with power and that they use a common PowerLine network password. If the problem occurred after you changed the password using the encryption utility on the CD, change the password back to its default setting. If this fixes the problem, refer to the *XEPS103 Space-Saving Powerline Network Extender Installation Guide* for instructions on setting the network password.

For more help with troubleshooting, see the *XEPS103 Space-Saving Powerline Network Extender Installation Guide* on the *XEPS103 Resource CD*.

Technical Support

Thank you for selecting NETGEAR products.

After completing installation, register your product at <http://www.NETGEAR.com/register>. Registration is required before you can use our telephone support service.

Go to <http://kbserver.netgear.com/products/XEPS103.asp> for product updates and Web support.



This symbol was placed in accordance with the European Union Directive 2002/96 on the Waste Electrical and Electronic Equipment (the WEEE Directive). If disposed of within the European Union, this product should be treated and recycled in accordance with the laws of your jurisdiction implementing the WEEE Directive.

© 2007 by NETGEAR, Inc. All rights reserved. NETGEAR is a registered trademark of NETGEAR, Inc. in the United States and/or other countries. Other brand and product names are trademarks or registered trademarks of their respective holders. Information is subject to change without notice.