



FAN COIL AIR CONDITIONERS

INSTALLATION, OPERATION, & MAINTENANCE

NEW RELEASE

Form 115.20-NOM6 (1106)

MODELS: YCW SERIES

YCW Series

2-pipe, 4-pipe

or

2-pipe, cooling with electric heat



LD11555

**YCWE with Bottom Return
Option (shown)**



LD11554

Basic YCW Series Unit



LD11556

**Basic YCW Series with Optional
Wall Panel (shown)**

Notes:

1. For proper operation, control valve must be normally closed.
2. Aquastats provided where required.
3. Electric Heat is available as an option.

******* WARNING TO INSTALLER, SERVICE PERSONNEL AND OWNER *******

Altering the product or replacing parts with non-authorized factory parts voids all warranty or implied warranty and may result in adverse operational performance and/or a possible hazardous safety condition to service personnel and occupants. Company employees and/or contractors are not authorized to waive this warning.

TABLE OF CONTENTS

| | |
|--------------------------------|---|
| RECEIVING..... | 3 |
| STORAGE..... | 3 |
| DESCRIPTION..... | 3 |
| FEATURES..... | 3 |
| CLEARANCES..... | 3 |
| MOUNTING - YCW UNIT STYLE..... | 3 |
| DUCTWORK..... | 5 |
| WIRING..... | 5 |
| PIPING..... | 7 |
| Piping Precautions..... | 7 |
| Drain Piping..... | 8 |

Reference Documents:

- Parts List, Fan Coil Air Conditioners Form 115.20-RP2 (Latest)

These documents can be ordered through Publications Dept. or downloaded @ <http://intranet.york.com/web0003/library/default.asp>

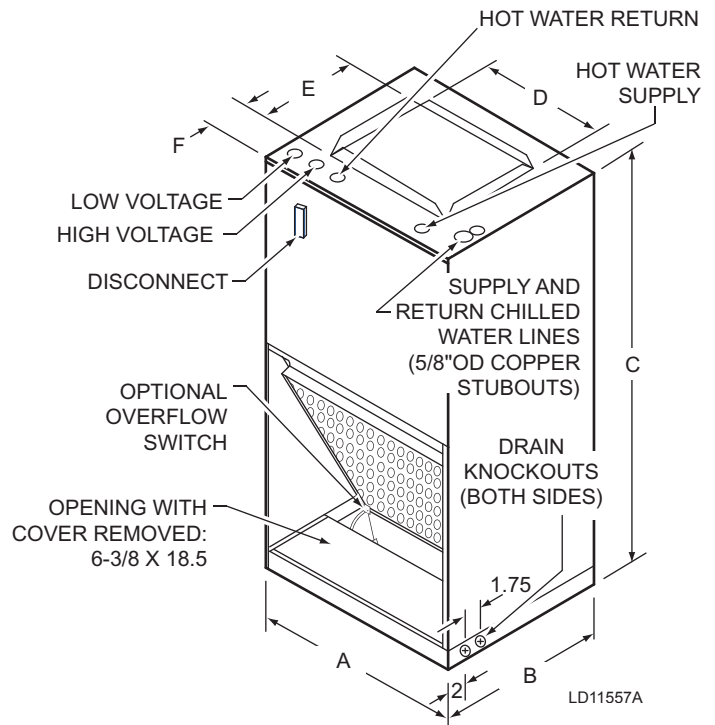
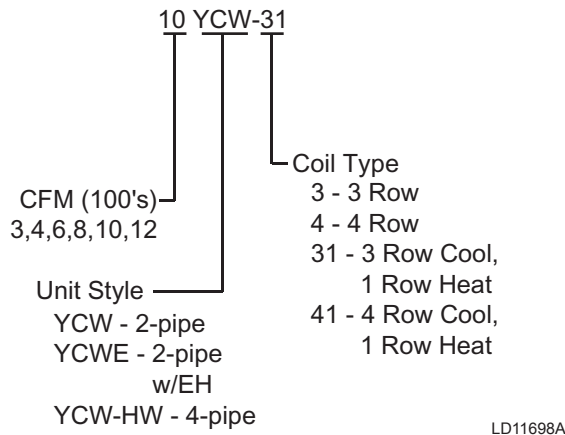

FIG. 1 – UNIT NOMENCLATURE

FIG. 2 – PHYSICAL DIMENSIONS (INCHES)

| CABINET DIMENSIONS (INCHES) | | | | | | | | | |
|-----------------------------|--------|--------|----|----|--------|-------|-------------|---------------------|-----|
| | A | B | C | D | E | F | FILTER SIZE | COIL CONN, OD SWEAT | |
| | | | | | | | | HW | CW |
| YCW | 22-1/8 | 15-1/8 | 40 | 14 | 10-1/2 | 3-5/8 | 18 X 18 | - | 5/8 |
| YCW-HW | 22-1/8 | 15-1/8 | 43 | 18 | 12-1/2 | 3-5/8 | 18 X 18 | 5/8 | 5/8 |
| YCWE | 22-1/8 | 15-1/8 | 40 | 14 | 10-1/2 | 3-5/8 | 18 X 18 | - | 5/8 |

INSTALLATION

RECEIVING

Material in this shipment has been inspected at the factory and released to the transportation agency in good condition. When received, a visual inspection of all cartons should be made immediately. Any evidence of rough handling or apparent damage should be noted on the delivery receipt and the material inspected in the presence of the carrier's representative.



If damage is found, a claim should be filed against the carrier immediately.

STORAGE

If the equipment is not to be immediately installed, store it in a dry location with the motor protected against moisture, dust, corrosion and physical damage. If units are to be stored for six months or longer, *see long term storage requirements (Form 50.20-NM3).*

DESCRIPTION

The YCW models are available as 2-pipe cooling (YCW), 2-pipe cooling with electric heat (YCWE) and a 4-pipe heating/cooling (YCW-HW). All units are provided with a 3-speed fan control in the control box in the fan section (left side), with 24v access on the top panel, left. Manual and auto changeover thermostats and the T200 auto speed control thermostats can be used with this unit. Twenty-four volt (24 v) power is provided in the unit for thermostat operation.

The 2-pipe cooling unit is provided with a single coil with connections on the top panel, right side.

The 2-pipe cooling with electric heat is provided with a single chilled water coil and electric heat elements; coil connections are on the top panel, right side; electrical connections are on the top panel, left side and the units are provided with a disconnect on the front panel.

The 4-pipe heating/cooling unit is provided with 2 coils with single end sheets – cooling connections are on the top panel, right side and the hot water connections are on the top panel, middle front.

This unit is designed to be installed vertically in the upflow position and can be installed on a closet plat-

form (platform not provided), hung on a closet wall (use wall hanging kit option) or recessed in a wall between wall studs (use front panel kit option).

FEATURES

Non-corrosive drain pan, installed in sloped position, 3/4" female primary and secondary connections accessible from either side or bottom.

Filters provided, are 1" throwaway accessible from the front.

Coils and fan motor/blower assemblies accessible from the front, when installed with the optional front panel assembly.

Front air return standard, optional bottom return available but requires bottom return option.

Options available are thermostats, wall front panels, condensate pan overflow switch, closet hanger bracket kit, bottom return air kit and chilled water coil valve packages. Consult applications group @ 717-771-7073 for details on ordering and availability of these options.

Cabinet is fully insulated with 1" coated fiberglass panels.

All units have 0" clearance to combustible surfaces, so the units can be installed against wall studs and drywall.

CLEARANCES

Clearance required in front of the unit to provide access to coils, electrical controls and motor/blower assembly. This clearance should be equal to the depth of the cabinet.

MOUNTING - YCW UNIT STYLE

Recessed In Wall

All units must be installed level to insure proper drainage and operation.

1. Frame the unit as required so the front panel of the wall unit will be flush with the drywall surface when installed (*see Fig. 3*).

INSTALLATION

2. Frame around the perimeter of the unit as required for securing the drywall. *See Table 1 below for drywall openings.*

| TABLE 1 - DRYWALL OPENINGS | |
|----------------------------|-------------------------------|
| MODEL NUMBER | DRYWALL CUTOUT DIM HT x WD |
| 3YWC | 28 x 42 |
| 4YWC | 28 x 50 |
| 6YWC | 28 x 58 |
| 8YWC | 28 x 66 |
| 10YWC | 28 x 74 |
| 12YWC | 28 x 82 |

3. Mount the unit in its permanent location, making sure it is level to insure proper drainage and operation (two 1/2" holes have been provided on each end of the unit for securing the unit to the wall studs).
4. After the drywall has been installed, recheck to make sure the unit's front panel is flush with the exterior drywall surface. Shimming of the unit may be required to get a seal between the unit and panel.

5. Install the wall panel to the front of the unit using the 1/4-20 x 1-1/2" long, painted, Phillips head screws (four on unit sizes 3, 4, 6 and 8; six on unit sizes 10 and 12) (1/4" cage nuts are located in the slotted front panel of the unit).
6. Remove the lower return air grille to get access to the filter.
7. *See Fig. 2 for unit details and dimensions.*

Hung on a Closet Wall

Unit can be mounted in a closet using the bracket support option 90PK3.

These brackets mount to the top, back of the cabinet. *See Fig 3 for location.*

The unit should be isolated from the wall to be sure sound is not transferred from the unit to the wall.

Platform Mounted in a Closet

Unit can be set on a platform (provided by others) in a closet.

Be sure to allow for sufficient space below the platform for drain piping.

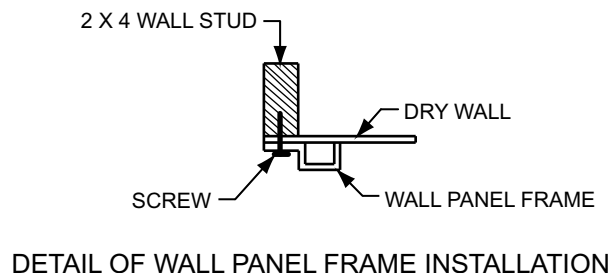
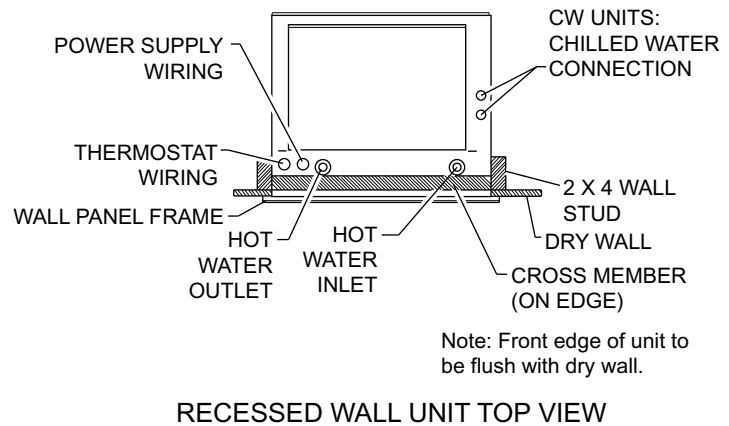
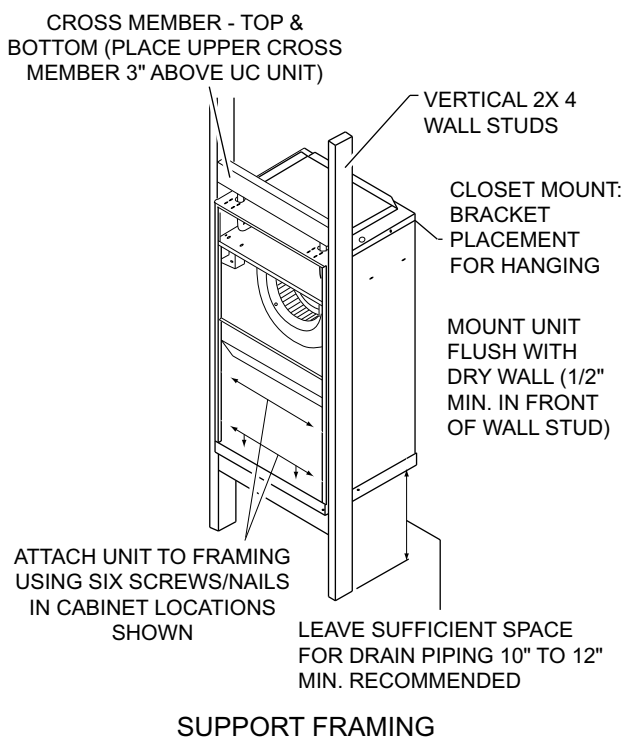

FIG. 3 – CW-HW RECESSED WALL and CLOSET MOUNTING

LD11695A

INSTALLATION

DUCTWORK

Ductwork recommendations are as follows:

- Insulate to prevent condensation during cooling.
- Size to the unit openings are generally acceptable but are determined by the engineering drawings.
- Be sure units are ducted per local codes or national codes, as applicable.

WIRING

Units are provided with wiring diagrams and nameplate data to provide information required for necessary field wiring. All wiring must comply with local and national code requirements.

Refer to Fig. 3 for access locations.

These units are provided with a class 2 transformer for 24-volt control circuits. Should any add-on equipment also have a class 2 transformer furnished, care must be taken to prevent interconnecting outputs of the two transformers by using a thermostat with isolating contacts. These units are supplied with a 3-speed control board.

The YCW units (2-pipe cooling) are provided as standard 120 volt power wired to a disconnect/terminal block and a ground lug. Fan motor hi, med and low speed leads are wired to the control board. There may be an unused motor lead from the motor – it needs to be capped off. The board is also wired to handle either 24v or 120v control wiring. To use 24v, remove jumpers on the control board. To use a 24v chilled water control valve, wire the valve in series with the “Y” connection from the control box, max of 20va. For 24v wiring using a T420 manual C/O, T421 auto C/O or the T200 speed control thermostats, you will need a 6-wire thermostat cable minimum.

The YCW-HW units (4-pipe heating/cooling) are provided as standard 120 volt power wired to a disconnect/terminal block and a ground lug. Fan motor hi, med and low speed leads are wired to the control board. There may be an unused motor lead from the motor – its needs to be capped off. The board is also wired to handle either 24v or 120v control wiring. To use 24v, remove jumpers on the control board. For your 24v hot water control valve, wire it in series with the “W” connection. For your 24v chilled water control valve, wire it in series with the “Y” connection. For 24v wiring using a T420 manual C/O, T421 auto C/O or the T200 speed control thermostats, you will need a 7-wire thermostat cable minimum.

The YCWE units (2-pipe cooling w/electric heat) are provided as standard 208/240 volt power wired to a disconnect switch with a ground lug. Fan motor hi, med and low speed leads are wired to the control board. There may be an unused motor lead from the motor – its needs to be capped off. The board is also wired to handle either 24v or 120v control wiring. To use 24v, remove jumpers on the control board. The transformer in the control box is 208/240v with a common terminal, one for 208v and one for 240v. Transformer is wired 240v from factory; for 208v application, move the ORG wire on the transformer to the 208v terminal. For your 24v chilled water control valve, wire it in series with the “Y” connection. When using a T420 manual C/O, T421 auto C/O or the T200 speed control thermostats, you will need a 7-wire thermostat cable minimum. *See Table 2 for MCA and MFS for each unit size/electric heat KW size.*

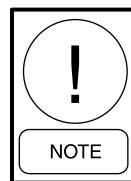

Any devices such as fan switches or thermostats that have been furnished by the factory for field installation must be wired in strict accordance with the wiring diagram that is supplied with the unit. Failure to do so could result in damage or injury.

| Table 2 - ELECTRICAL DATA | | | | | | | | | |
|----------------------------------|-----------|-------------|-------------|-------------------|-------------|---------------------------|-------------|-----------------------------------|-------------|
| UNIT MODEL | | KW | | TOTAL AMPS | | MIN. CIR. AMPACITY | | MAX.OVERCURRENT PROTECTION | |
| | | 240V | 208V | 240V | 208V | 240V | 208V | 240V | 208V |
| 4CWE | 0 | 0 | 0.0 | 1.1 | N/A | N/A | N/A | N/A | N/A |
| | 1 | 1 | 0.8 | 5.3 | 4.7 | 7 | 6 | 15 | 15 |
| | 2 | 2 | 1.5 | 9.4 | 8.3 | 12 | 11 | 15 | 15 |
| | 3 | 3 | 2.3 | 13.6 | 11.9 | 17 | 15 | 20 | 15 |
| | 4 | 4 | 3.0 | 17.8 | 15.5 | 23 | 20 | 25 | 20 |
| 6CWE | 0 | 0 | 0.0 | 1.1 | N/A | N/A | N/A | N/A | N/A |
| | 2 | 2 | 1.5 | 9.4 | 8.3 | 12 | 11 | 15 | 15 |
| | 3 | 3 | 2.3 | 13.6 | 11.9 | 17 | 15 | 20 | 15 |
| | 4 | 4 | 3.0 | 17.8 | 15.5 | 23 | 20 | 25 | 20 |
| | 5 | 5 | 3.8 | 21.9 | 19.1 | 28 | 24 | 30 | 25 |
| | 6 | 6 | 4.5 | 26.1 | 22.7 | 33 | 29 | 35 | 30 |
| 8CWE | 0 | 0 | 0.0 | 1.7 | N/A | N/A | N/A | N/A | N/A |
| | 3 | 3 | 2.3 | 14.2 | 12.5 | 18 | 16 | 20 | 20 |
| | 4 | 4 | 3.0 | 18.4 | 16.1 | 23 | 21 | 25 | 25 |
| | 5 | 5 | 3.8 | 22.5 | 19.7 | 29 | 25 | 30 | 25 |
| | 6 | 6 | 4.5 | 26.7 | 23.5 | 34 | 30 | 35 | 30 |
| | 8 | 8 | 6.0 | 35.0 | 30.5 | 44 | 39 | 50 | 40 |
| 10CWE | 0 | 0 | 0.0 | 2.7 | N/A | N/A | N/A | N/A | N/A |
| | 3 | 3 | 2.3 | 15.2 | 13.5 | 19 | 17 | 20 | 20 |
| | 5 | 5 | 3.8 | 23.5 | 20.7 | 30 | 26 | 30 | 30 |
| | 6 | 6 | 4.5 | 27.7 | 24.3 | 35 | 31 | 35 | 35 |
| | 8 | 8 | 6.0 | 36 | 31.5 | 45 | 40 | 50 | 40 |
| | 10 | 10 | 7.5 | 44.4 | 38.8 | 56 | 49 | 60 | 50 |

INSTALLATION

PIPING

All piping connections are 5/8" OD copper tubing (see Fig.4).

The supply and return piping must be adequately sized to meet the design water flow requirements as specified for the specific installation. All chilled water piping must be insulated to prevent condensation. It is also recommended that all piping be insulated to prevent freezing when piping is run in an unconditioned space.

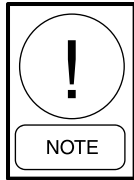

Coil freeze protection is recommended for applications where the fan coil is located in ambient air locations (attics, crawl spaces, etc.) or within structures that may be unoccupied during freezing conditions. Consult the factory for additional information.

Piping Precautions

- Flush all piping prior to connection to remove all debris.
- Use wet cotton rags to cool valve bodies when soldering.
- Open all valves (midway for hand valves, manually open on motorized valves) prior to soldering.



When connecting piping or valve kits to fan coil units, do not bend or reposition the coil header tubing for alignment purposes. This could cause a tubing fracture resulting in a water leak when water pressure is applied to the system

- When soldering to bronze or brass, heat the piping while in the socket/cup and begin introducing the solder when the flux boils rapidly. Avoid direct flame into the solder joint.
- Heat can only be applied to the cup of the valve body for a minimal time before damage occurs (even with the use of wet rags).
- Avoid rapid quenching of solder joints, as this will produce joints of inferior quality.
- Connect all piping per accepted industry standards and observe all regulations governing installation of piping systems. When all connections are complete, the system must be pressure tested. Repair any solder joint leaks and gently tighten any leaking valve packing nuts and piping accessories as required. Hydronic systems are not designed to hold pressurized air and should only be tested with water.



FIG. 4 – CW-HW SERIES UPFLOW WALL/ CLOSET FAN COILS
4-Pipe Chilled Water-Hot Water (190 - 1085 CFM)

INSTALLATION

Drain Piping

Condensate drain lines must be installed with adequate slope away from the unit to assure positive drainage. Since the drain pan is located on the suction side of the blower, a negative pressure exists at the drain pan and a minimum trap of 1-1/2" must be provided in the drain line to assure proper drainage.

Drain connections, primary and secondary, are 3/4" MPT (see Fig. 5 for details).



On units with plastic drain pans the drain connections must be made hand tight only.

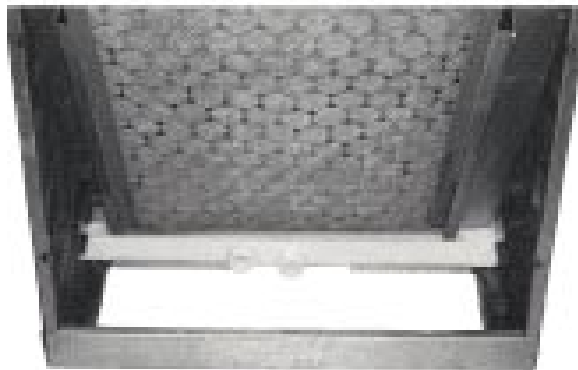

CONDENSATE DRAIN CONNECTIONS
(With drain cover removed)
(Thermoplastic pan shown)

FIG. 5 – CWE SERIES WALL/CLOSET FAN COILS
Chilled Water with Electric Heat

SEQUENCE OF OPERATION

YCW With a Chilled Water Coil

The unit will respond to a cooling command from the thermostat by powering a water control valve open. The fan will operate at the speed selected at the thermostat. When the space reaches the temperature setpoint at the thermostat, the cooling valve will close and the fan will continue to operate.

When using the T420 manual C/O thermostat and the TB3-3/TB2-5 jumper is in place, the fan will continue to operate at the fan speed selected. Removing the jumper will cause the fan to shut down when the thermostat is satisfied.

When using the T200 thermostat, the stat will automatically regulate the fan speed based on the difference between the space temp and setpoint - @ 4°F off setpoint, the fan will run @ HI; @ 3°F off setpoint, the fan will run @ MED; @ 2°F off setpoint, the fan will run @ LO. When the thermostat is satisfied, the water valve will be deenergized and the fan will revert to LO speed.

The YCW-HW with Both a Chilled Water Coil and a Hot Water Coil.

The unit control thermostat, on a call for heating, will energize the hot water control valve. When the thermostat is set for cooling, it will energize the chilled water valve on a call for cooling. The fan will operate at the speed selected at the thermostat. When the space reaches the temperature setpoint at the thermostat, the cooling valve will close (on cooling) or the heating valve will close (on heating) and the fan will continue to operate.

When using the T420 manual C/O thermostat and the TB3-3/TB2-5 jumper is in place, the fan will continue to operate at the fan speed selected. Removing the jumper will cause the fan to shut down when the thermostat is satisfied.

When using the T421 auto C/O thermostat and the TB3-3/TB2-5 jumper is in place, the fan will continue to operate at the fan speed selected. Removing the jumper will cause the fan to shut down when the thermostat is satisfied.

When using the T200 thermostat, the stat will automatically regulate the fan speed based on the difference between the space temp and setpoint - @ 4°F off setpoint, the fan will run @ HI; @ 3°F off setpoint, the fan will run @ MED; @ 2°F off setpoint, the fan will run @ LO. When the thermostat is satisfied, the water valve will be deenergized and the fan will revert to LO speed.

The YCWE With Both a Chilled Water Coil and Electric Heating Coil.

The unit control thermostat, on a call for heating, will energize the heater contactor(s). When the thermostat is set for cooling, it will energize the chilled water valve on a call for cooling. The fan will operate at the speed selected at the thermostat. When the space reaches the temperature setpoint at the thermostat, the cooling valve will close (on cooling) or the heating contactors will open (on heating) and the fan will continue to operate.

When using the T420 manual C/O thermostat and the TB3-3/TB2-5 jumper is in place, the fan will continue to operate at the fan speed selected. Removing the jumper will cause the fan to shut down when the thermostat is satisfied.

When using the T421 auto C/O thermostat and the TB3-3/TB2-5 jumper is in place, the fan will continue to operate at the fan speed selected. Removing the jumper will cause the fan to shut down when the thermostat is satisfied.

When using the T200 thermostat, the stat will automatically regulate the fan speed based on the difference between the space temp and setpoint - @ 4°F off setpoint, the fan will run @ HI; @ 3°F off setpoint, the fan will run @ MED; @ 2°F off setpoint, the fan will run @ LO. When the thermostat is satisfied, the water valve will be deenergized (on cooling) or the heating contactor will open (on heating) and the fan will revert to LO speed.

MAINTENANCE

MOTOR

The blower motor should be cleaned annually and if it has oiling ports, it should be oiled with a good grade of SAE 20 oil. Normally a few drops of oil in each bearing is sufficient.

COIL

The coil must be kept clean by any of the following methods.

1. Cleaning with low-pressure compressed air.
2. Flushing or rinsing with water (a detergent is advisable for greasy surfaces).

FILTERS

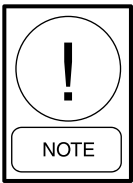

Clean or replace air filters regularly

The intervals at which filters require replacement depend on local conditions.

Because of dust and lint in the room, room-air filters load up much more rapidly than outdoor-air filters. Under normal conditions, the room air filter requires replacement every six to eight weeks.

To ensure proper maintenance of the filters, it is best to follow an organized maintenance procedure. The following one is recommended:

Divide the total number of units on the job into six equal groups. Each week inspect, clean or replace the filters in each group, in rotation. This insures a uniform servicing interval. The interval may be lengthened or shortened as determined by experience. If inspection shows only the room-air filter to be dirty, this one alone should be replaced.

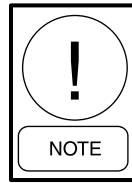

Dirty filters reduce the air and heating capacities of the unit. When the filters are excessively dirty, the unit heating capacity will be so reduced that it is ineffective for heating the room. When a room fails to heat, always check the filters.

CLEAN UNIT INTERIOR

Once a year clean the fans and coils of the unit thoroughly. Remove the access panel as necessary.

Wipe the interior of the unit clean with a rag. Wipe the motor and inside and outside of the fan housings. (In cooling units, clean out the drain pan.)

This Page Intentionally Left Blank

FAN COILS START-UP CHECKLIST

INSTALL CHECKLIST

| |
|---|
| <input type="checkbox"/> Equipment received as ordered. |
| <input type="checkbox"/> Unit checked for damage interior and exterior. |
| <input type="checkbox"/> Make sure all ductwork is complete and available for full air flow. |
| <input type="checkbox"/> Unit installed level to ensure proper drainage and operation. |
| <input type="checkbox"/> Unit installed with proper clearances. |
| <input type="checkbox"/> Ensure condensate water will drain toward the drain connection. An overflow drain may be required as a back up to a clogged primary drain. |
| <input type="checkbox"/> Check that coil(s), valves and piping have been leak checked and insulated as required. |
| <input type="checkbox"/> Main coil drain pan must be properly trapped and charged with water before units are started. |
| <input type="checkbox"/> Ensure that all air has been vented from the system. |
| <input type="checkbox"/> Return valves to their proper operating positions prior to start-up. |
| <input type="checkbox"/> Repair any solder joint leaks and gently tighten any leaking valve packing nuts and piping accessories as required. |
| <input type="checkbox"/> Install all panels. |

CLEANING CHECKLIST

| |
|--|
| <input type="checkbox"/> Installer has cleaned out interior. |
| <input type="checkbox"/> Ensure drain pan free from foreign material. |
| <input type="checkbox"/> Ensure air filters are clean, installed properly and secured. Use the directional arrows or other information on the filter to determine the proper flow direction. |

CONTROLS CHECKLIST

| |
|--|
| <input type="checkbox"/> Check that supply voltage matches nameplate data. |
| <input type="checkbox"/> Ensure that the unit is properly grounded. |
| <input type="checkbox"/> Controls installation complete |
| <input type="checkbox"/> Check all electrical connections for tightness. |
| <input type="checkbox"/> Review electrical print for correct wiring. |

FAN INSPECTION - *The fan should be inspected and cleaned, in conjunction with maintenance of the motor and bearings. It is important to keep the wheel clean in order to avoid imbalance and vibration.*

| |
|---|
| <input type="checkbox"/> Check tightness of fan bearing locking collar. |
| <input type="checkbox"/> With power off, check blower wheel set screws for tightness and ensure that the blower wheel(s) rotate freely and quietly. |
| <input type="checkbox"/> Check tightness of all motor base and mounting bolts. |
| <input type="checkbox"/> Check motor connections to ensure that they are secure and made in accordance with the wiring diagram |
| <input type="checkbox"/> Rotate all moving components manually. Adjust as required. |
| <i>NOTE: If the motor and fan have not been operated in the last (4) four weeks or more, lubricate all the bearings and rotate the motor and fan monthly to prevent moisture from accumulating in the bearings. (See Form 50.20-NM3, Long Term Storage)</i> |

