

YORK[®]

Heating and Air Conditioning

TECHNICAL GUIDE

96% TWO STAGE VARIABLE SPEED GAS-FIRED RESIDENTIAL MULTI-POSITION GAS FURNACES

MODELS: TM9V

**NATURAL GAS
60 - 120 MBH INPUT**



Due to continuous product improvement, specifications are subject to change without notice.

Visit us on the web at www.york.com for the most up-to-date technical information.

Additional efficiency rating information can

WARRANTY

Lifetime limited warranty on both heat exchangers to the original purchaser; a 20-year limited warranty from original installation date to subsequent purchaser.

10-year warranty on the heat exchanger in commercial applications.

5-year limited parts warranty.

DESCRIPTION

These compact units employ induced combustion, reliable hot surface ignition and high heat transfer aluminized tubular heat exchangers. The units are factory shipped for installation in upflow or horizontal applications and may be converted for downflow applications.

These furnaces are designed for residential installation in a basement, closet, alcove, attic, recreation room or garage and are also ideal for commercial applications. All units are factory assembled, wired and tested to assure safe dependable and economical installation and operation.

These units are Category IV listed and may be vented either through side wall or roof applications using approved plastic combustion air and vent piping.

FEATURES

- Two stage heating operation includes two stage gas valve, two stage inducer operation and variable speed ECM blower operation. Adjustable delay timer allows two stage operation with a single stage thermostat.
- Easily applied in upflow, horizontal left or right, or downflow installation with minimal conversion necessary.
- Compact, easy to install, ideal height 33" tall cabinet.
- ECM variable speed drive for cooling SEER enhancement, improved comfort with optional airflow delay profiles, and continuous fan options for IAQ performance.
- Easy access to controls to connect power/control wiring.
- Built-in, high level self diagnostics with fault code display.
- Low unit amp requirement for easy replacement application.
- All models are convertible to use propane (LP) gas.
- Electronic Hot Surface Ignition saves fuel cost with increased dependability and reliability.
- 100% shut off main gas valve for extra safety.
- 24V, 40 VA control transformer and blower relay supplied for add-on cooling.
- Hi-tech tubular aluminized steel primary heat exchanger with stainless steel tube/aluminum fin secondary heat exchanger for outstanding efficiency.
- Solid removable bottom panel allows easy conversion.
- Airflow leakage less than 1% of nominal airflow for ductblaster conditions.
- No knockouts to deal with, making installation easier.
- Movable duct connector flanges for application flexibility.
- Quiet inducer operation, burner, and blower operation.
- Inducer rotates for easy conversion of venting options.
- Fully supported blower assembly for easy access and removal of blower.
- External air filters used for maximum flexibility in meeting customers IAQ needs.
- Insulated blower compartment for thermal and acoustic performance.
- 1/4 turn knobs provided for easy independent door removal.
- Internal condensate trap design (patent pending) provides condensate management options, easy visual operation check, and is self priming to prevent nuisance problems.
- Protection included from air intake, exhaust vent or condensate blockage.
- Venting applications maybe installed as either 2 pipe sealed combustion or single pipe vent using indoor combustion air.

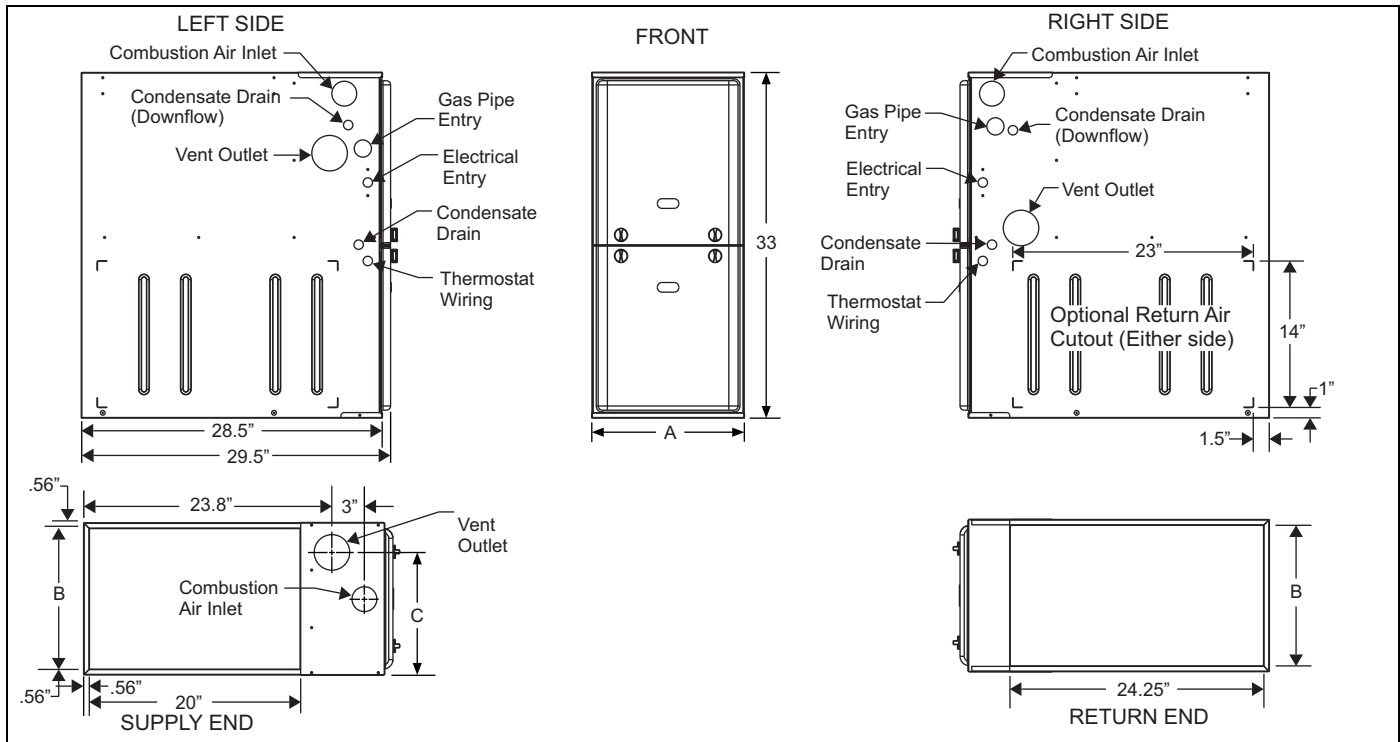

Cabinet & Duct Dimensions

Model	Nominal CFM (m ³ /min)	Cabinet Size	Cabinet Dimensions (Inches)			Approximate Operating Weights
			A	B	C	Lbs
TM9V060B12MP11	1200	B	17 1/2	16 3/8	13 1/4	122
TM9V080B12MP11	1200	B	17 1/2	16 3/8	13 1/4	126
TM9V080C16MP11	1600	C	21	19 7/8	16 1/2	136
TM9V100C16MP11	1600	C	21	19 7/8	18 1/4	142
TM9V100C20MP11	2000	C	21	19 7/8	18 1/4	145
TM9V120D20MP11	2000	D	24 1/2	23 3/8	21 3/4	156

Ratings & Physical / Electrical Data

Model	Input High/Low	Output High/Low	Total Unit	AFUE	High Fire Air Temp. Rise	Low Fire Air Temp. Rise
	MBH	MBH	Amps	%	°F	°F
TM9V060B12MP11	60/39	58/37	9	96	35 - 65	35 - 65
TM9V080B12MP11	80/52	77/50	9	96	35 - 65	30 - 60
TM9V080C16MP11	80/52	77/50	12	96	35 - 65	35 - 65
TM9V100C16MP11	100/65	96/62	12	96	35 - 65	30 - 65
TM9V100C20MP11	100/65	96/62	14	96	35 - 65	35 - 65
TM9V120D20MP11	120/78	115/75	14	96	35 - 65	35 - 65
Model	Max. Outlet Air Temp.	Blower		Blower Size	Max. Over-current Protect	Min. Wire Size (awg) @ 75 ft. One Way
	°F	HP	Amps	In.		
TM9V060B12MP11	170	1/2	7	11 x 8	15	14
TM9V080B12MP11	175	1/2	7	11 x 8	15	14
TM9V080C16MP11	175	3/4	10.2	11 x 10	15	14
TM9V100C16MP11	175	3/4	10.2	11 x 10	15	14
TM9V100C20MP11	175	1	12.7	11 x 11	20	12
TM9V120D20MP11	170	1	12.7	11 x 11	20	12

Annual Fuel Utilization Efficiency (AFUE) numbers are determined in accordance with DOE Test procedures. Wire size and over current protection must comply with the National Electrical Code (NFPA-70-latest edition) and all local codes. The furnace shall be installed so that the electrical components are protected from water.

FILTER PERFORMANCE

The airflow capacity data published in the "Blower Performance" table listed above represents blower performance WITHOUT filters.

All applications of these furnaces require the use of field installed air filters. All filter media and mounting hardware or provisions must be field installed external to the furnace cabinet. DO NOT attempt to install any filters inside the furnace.

NOTE: Single side return above 1800 CFM is approved as long as the filter velocity does not exceed filter manufacturer's recommendation and a transition is used to allow use on a 20x25 filter.

Recommended Filter Sizes (High velocity 600 FPM)

CFM	Cabinet Size	Side (in)	Bottom (in)
1200	B	16 x 25	16 x 25
1600	C	16 x 25	20 x 25
2000	C	(2) 16 x 25	20 x 25
2000	D	(2) 16 x 25	22 x 25

NOTES:

- Air velocity through throwaway type filters may not exceed 300 feet per minute (91.4 m/min). All velocities over this require the use of high velocity filters.
- Do not exceed 1800 CFM using a single side return and a 16x25 filter. For CFM greater than 1800, you may use two side returns or one side and the bottom or one return with a transition to allow use of a 20x25 filter.

Unit Clearances to Combustibles

Application	Upflow	Downflow	Horizontal
Top	1"	0"	0"
Vent	0"	0"	0"
Rear	0"	0"	0"
Side	0"	0"	1"
Front*	0"	0"	0"
Floor	Combustible	Combustible ¹	Combustible
Closet	Yes	Yes	Yes
Line Contact	No	No	Yes

- For combustible floors only when used with special sub-base.
* - 24" clearance in front and 18" on side recommended for service access.
All furnaces approved for alcove and attic installation.

ACCESSORIES

PROPANE (LP) CONVERSION KIT -

S1-1NP0347 - All Models

This accessory conversion kit may be used to convert natural gas (N) units for propane (LP) operation.

CONCENTRIC VENT TERMINATION -

S1-1CT0302 (2") & S1-1CT0302-636 (2")

S1-1CT0303 (3") & S1-1CT0303-636 (3")

For use through rooftop, sidewall. Allows combustion air to enter and exhaust to exit through single common hole. Eliminates unsightly elbows for a cleaner installation.

SIDEWALL VENT TERMINATION KIT -

S1-1HT0901 (3")

S1-1HT0902 (2")

For use on sidewall, two-pipe installations only. Provide a more attractive termination for locations where the terminal is visible on the side of the home.

CONDENSATE NEUTRALIZER KIT - 1NK0301

Neutralizer cartridge has a 1/2" plastic tube fittings for installation in the drain line. Calcium carbonate refill media is also available from the Source 1 Parts (p/n 026-30228-000).

SIDE RETURN FILTER RACKS -

S1-1SR0200 - All Models

S1-1SR0402 - All Models

BOTTOM RETURN FILTER RACKS -

S1-1BR0517 or 1BR0617 - For 17-1/2" cabinets

S1-1BR0521 or 1BR0621 - For 21" cabinets

S1-1BR0524 or 1BR0624 - For 24-1/2" cabinets

1BR05xx series are galvanized steel filter racks. 1BR06xx are pre-painted steel filter racks to match the appearance of the furnace cabinet.

COMBUSTIBLE FLOOR BASE KIT -

For installation of these furnaces in downflow applications directly onto combustible flooring material, These kits are required to prevent potential overheating situations. tible floor base kit provides access for combustible airflow.

S1-1CB0517 - For 17-1/2" cabinets

S1-1CB0521 - For 21" cabinets

S1-1CB0524 - For 24-1/2" cabinets

EAC TRANSITION KITS -

For installation of EAC accessories with these furnaces to provide easy transition of return airflow through the EAC to get the proper sealing and reduced airflow leakage.

S1-1TK1001 - For all models using side return

S1-1TK1017 - For 17-1/2" cabinets using bottom return

S1-1TK1021 - For 21" cabinets using bottom return

S1-1TK1024 - For 24-1/2" cabinets using bottom return

HIGH ALTITUDE PRESSURE SWITCHES -

For installation where the altitude is less than 5,000 feet it is not required that the pressure switch be changed. For altitudes above 5,000 feet, see kits below.

S1-1PS3306 - 080

S1-1PS3307 - 060

S1-1PS3302 - 100, 120

ROOM THERMOSTATS - A wide selection of compatible thermostats are available to provide optimum performance and features for any installation.

1H/1C, manual change-over electronic non-programmable thermostat.

1H/1C, auto/manual changeover, electronic programmable, deluxe 7-day, thermostat.

1H/1C, auto/manual changeover, electronic programmable.

* For the most current accessory information, refer to the price book or consult factory.

AIR FLOW DATA

HIGH / LOW SPEED COOLING AND HEAT PUMP CFM						
060B12		080B12		Jumper Settings		
High	Low	High	Low	COOL Tap	ADJ Tap*	
1343	865	1320	882	A	B	
1116	727	1093	755	B	B	
1235	791	1203	810	A	A	
1026	661	1001	693	B	A	
1079	709	1080	730	A	C	
889	590	880	641	C	B	
900	599	910	642	B	C	
787	531	803	585	D	B	
814	542	836	597	C	A	
712	490	738	557	D	A	
725	499	749	561	C	C	
641	456	682	529	D	C	
080C16		100C16		Jumper Settings		
High	Low	High	Low	COOL Tap	ADJ Tap*	
1787	1171	1818	1192	A	B	
1503	987	1545	1030	B	B	
1620	1053	1661	1083	A	A	
1405	914	1427	936	B	A	
1462	964	1497	991	A	C	
1217	785	1234	819	C	B	
1245	818	1265	832	B	C	
940	608	977	648	D	B	
1091	702	1116	728	C	A	
852	551	884	572	D	A	
983	626	1019	666	C	C	
764	544	791	519	D	C	
100C20		120D20		Jumper Settings		
High	Low	High	Low	COOL Tap	ADJ Tap*	
2019	1290	2006	1397	A	B	
1790	1174	1687	1131	B	B	
1818	1195	1845	1282	A	A	
1630	1068	1552	1050	B	A	
1649	1082	1694	1157	A	C	
1269	848	1502	1011	C	B	
1432	956	1400	944	B	C	
1078	704	1365	922	D	B	
1169	770	1364	931	C	A	
986	638	1232	808	D	A	
1062	685	1225	808	C	C	
866	576	1117	718	D	C	
HIGH / LOW HEAT CFM						
060B12		80B12		Jumper Settings		
High	Low	High	Low	HEAT Tap	ADJ Tap*	
1364	843	1433	945	A	Any	
1253	745	1320	887	B	Any	
1102	660	1223	840	C	Any	
1014	607	1134	768	D	Any	
80C16		100C16		Jumper Settings		
High	Low	High	Low	HEAT Tap	ADJ Tap*	
1684	1095	1795	1171	A	Any	
1542	1011	1585	1047	B	Any	
1426	927	1420	929	C	Any	
1289	832	1201	785	D	Any	
100C20		120D20		Jumper Settings		
High	Low	High	Low	HEAT Tap	ADJ Tap*	
2194	1417	1937	1323	A	Any	
1999	1290	1757	1199	B	Any	
1799	1182	1594	1062	C	Any	
1614	1062	1429	957	D	Any	

All CFM's are shown at 0.5" w.c. external static pressure. These units have variable speed motors that automatically adjust to provide constant CFM from 0.0" to 0.6" w.c. static pressure. From 0.6" to 1.0" static pressure, CFM is reduced by 2% per 0.1" increase in static. Operation on duct systems with greater than 1.0" w.c. external static pressure is not recommended.

NOTE: At some settings, LOW COOL and/or LOW HEAT airflow may be lower that what is required to operate an airflow switch on certain models of electronic air cleaners. Consult the instructions for the electronic air cleaner for further details.

* The ADJ "D" tap should not be used.