

YORK®

Heating and Air Conditioning

TECHNICAL GUIDE

SPLIT-SYSTEM HEAT PUMPS

13 SEER – R-410A

MODELS:
THGD18 THRU 60
(1.5 THRU 5 NOMINAL TONS, 1 PHASE)



Due to continuous product improvement, specifications are subject to change without notice.

Visit us on the web at www.york.com

Additional rating information can be found at www.ahridirectory.org

DESCRIPTION

The heat pump condensing unit is the outdoor part of a versatile system of heating and air conditioning. It is designed to be custom-matched with one of UPG's complete line of evaporator sections, with each serving a specific function. Matching Air Handlers are available for upflow, downflow, or horizontal applications to provide a complete system. Electric Heaters are available, if required. Add-on coils are available for use with upflow, downflow, or horizontal furnaces and air handlers.

WARRANTY

Single Phase Units:

5-year limited parts warranty.

5-year limited compressor warranty.

FEATURES

- **QUALITY CONDENSER COILS** - The coil is constructed of copper tubing and enhanced aluminum fins for increased efficiency and corrosion protection.
- **PROTECTED COMPRESSOR** - The compressor is internally protected against high pressure, temperature, and externally by a factory installed high pressure switch. This is accomplished by the simultaneous operation of high pressure relief valve and a temperature sensor which protects the compressor if undesirable operating conditions occur. A liquid line filter-drier further protects the compressor.
- **DURABLE FINISH** - The cabinet is made of pre-painted steel. The pre-treated galvanized steel provides a better paint to steel bond, which resists corrosion and rust creep. Special primer formulas and matted-textured finish insure less fading when exposed to sunlight.
- **LOWER INSTALLED COST** - Installation time and costs are reduced by easy power and control wiring connections. Available in sweat connect models only. The unit contains enough refrigerant for matching indoor coils and 15 feet of interconnecting piping. The small base dimension means less space is required on the ground or roof.
- **TOP DISCHARGE** - The warm air from the top mounted fan is blown up away from the structure and any landscaping. This allows compact location on multi-unit applications.
- **LOW OPERATING SOUND LEVEL** - The upward air flow carries the normal operating noise away from the living area. The rigid top panel effectively isolates any motor sound. Isolator mounted compressor and the rippled fins of the condenser coil muffle the normal fan motor and compressor operating sounds.
- **LOW MAINTENANCE** - Long life permanently lubricated motor-bearings need no annual servicing.
- **EASY SERVICE ACCESS** - Fully exposed refrigerant connections, and a single panel covering the electrical controls make for easy servicing of the unit.
- **SECURED SERVICE VALVES** - Secured re-usable service valves are provided on both the liquid and vapor sweat connections for ease of evacuating and charging.
- **U.L. and C.U.L. listed** - approved for outdoor application.

Certified in accordance with the Unitary Small Equipment certification program, which is based on ARI Standard 210/240.

Physical and Electrical Data

MODEL		THGD18 S41S1	THGD24 S41S1	THGD30 S41S1	THGD36 S41S1	THGD42 S41S1	THGD48 S41S1	THGD60 S41S1
Unit Supply Voltage		208-230V, 1 ϕ , 60Hz						
Normal Voltage Range ¹		187 to 252						
Minimum Circuit Ampacity		9.6	12.0	15.4	19.6	28.6	30.9	37.4
Max. Overcurrent Device Amps ²		15	20	25	30	50	50	60
Min. Overcurrent Device Amps ³		15	15	20	20	30	35	40
Compressor Type		Recip	Recip	Recip	Recip	Scroll	Scroll	Scroll
Compressor Amps	Rated Load	7.12	8.9	11.65	14.72	21.76	23.61	28.79
	Locked Rotor	47.0	48.0	60.0	83.0	105.0	150.0	150
Crankcase Heater		Yes	Yes	Yes	Yes	No	No	No
Fan Motor Amps	Rated Load	0.70	0.80	0.80	1.5	1.5	1.5	1.5
Fan Diameter Inches		24	24	24	24	24	24	24
Fan Motor	Rated HP	1/10	1/8	1/8	1/4	1/4	1/4	1/4
	Nominal RPM	825	1075	1075	850	850	850	850
	Nominal CFM	2200	2900	3100	3800	3200	3000	3000
Coil	Face Area Sq. Ft.	15.7	18.3	21.0	23.58	23.58	23.58	23.58
	Rows Deep	1	1	1	1	1	2	2
	Fin / Inches	22	22	22	22	22	18	18
Liquid Line Set OD (Field Installed)		3/8	3/8	3/8	3/8	3/8	3/8	3/8
Vapor Line Set OD (Field Installed)		3/4	3/4	3/4	3/4	7/8	7/8	7/8
Unit Charge (Lbs. - Oz.) ⁴		6 - 5	8 - 7	9 - 12	9 - 15	9 - 12	13 - 9	13 - 6
Charge Per Foot, Oz.		.62	.62	.62	.62	.67	.67	.67
Operating Weight Lbs.		172	184	196	208	208	275	280

1. Rated in accordance with ARI Standard 110, utilization range "A".
2. Dual element fuses or HACR circuit breaker. Maximum allowable overcurrent protection.
3. Dual element fuses or HACR circuit breaker. Minimum recommended overcurrent protection.
4. The Unit Charge is correct for the outdoor unit, matched indoor coil and 15 feet of refrigerant tubing. For tubing lengths other than 15 feet, add or subtract the amount of refrigerant, using the difference in length multiplied by the per foot value.

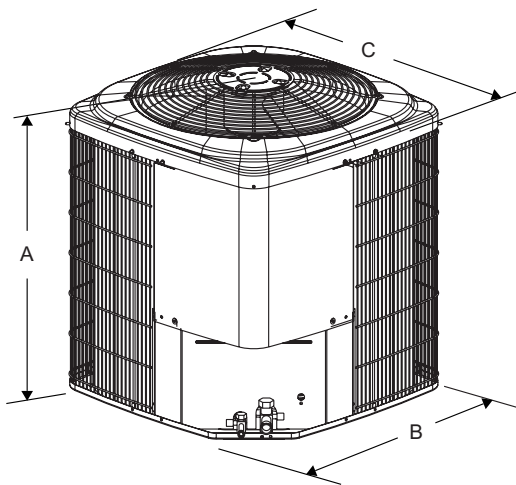

All dimensions are in inches. They are subject to change without notice. Certified dimensions will be provided upon request.

Unit Model	Dimensions (Inches)			Refrigerant Connection Service Valve Size	
	A ¹	B	C	Liquid	Vapor
18	28	34	34	3/8"	3/4"
24	32	34	34		
30	36	34	34		
36	40	34	34		
42	40	34	34		
48	40	34	34	7/8"	
60	40	34	34		

1. Including Fan Guard.

Additional R-410A Charge / Orifice Size for Various Matched Systems							
Outdoor Unit	THGD18 S41S1	THGD24 S41S1	THGD30 S41S1	THGD36 S41S1	THGD42 S41S1	THGD48 S41S1	THGD60 S41S1
Required Orifice or TXV ^{1,2}	1TVM0901	1TVM0903	1TVM0903	1TVM0904	1TVM0904	1TVM0905	1TVM0906
Factory Charge, lbs-oz	6 - 5	8 - 7	9 - 12	9 - 15	9 - 12	13 - 9	13 - 6
Indoor Coil ^{3,4}	Additional Charge, Oz						
FC/MC/PC/UC18AB	0	-	-	-	-	-	-
FC/MC/PC/UC24AB	+ 4	0	-	-	-	-	-
FC/MC/PC30AB	-	0	-	-	-	-	-
FC/MC/PC32A	-	0	0	-	-	-	-
FC/MC/PC35BC	-	0	0	-	-	-	-
FC/MC/PC37A	-	-	0	0	-	-	-
FC/MC/PC43BC	-	-	0	0	-	-	-
FC/MC/PC/UC48CD	-	-	-	+ 10	0	0	-
FC/MC/PC/UC60CD	-	-	-	-	0	0	-
FC/MC62D	-	-	-	-	-	+ 12	0
HC18A	+ 1	-	-	-	-	-	-
HC30A	+ 10	0	-	-	-	-	-
HC36B	-	0	0	-	-	-	-
HC42	-	-	0	0	0	-	-
HC60	-	-	-	-	0	0	-
HD24	+ 14	-	-	-	-	-	-
HD36	-	+ 2	-	-	-	-	-
HD48	-	-	+ 8	+ 8	-	-	-
HD60	-	-	-	-	0	+ 7	-
AHP18	0	-	-	-	-	-	-
AHP30	-	0	-	-	-	-	-
AHP36	-	-	0	0	-	-	-
AHP/SHP48	-	-	-	-	0	0	-
AHP/SHP60	-	-	-	-	-	0	-
AV24	+ 3	0	-	-	-	-	-
AV36	-	6	0	0	-	-	-
AV/SV48	-	-	-	-	0	0	-
AV/SV60	-	-	-	-	-	0	-
F4FP24	See Caution below	0	-	-	-	-	-
F4FP30	See Caution below	-	0	-	-	-	-
F4FP40	See Caution below	-	-	0	-	-	-
F4FP45	See Caution below	-	-	-	0	0	-
F5FP48	See Caution below	-	-	-	-	0	0
F4FV60	See Caution below	-	-	-	-	-	0
F5FP60	See Caution below	-	-	-	-	-	0

FOOTNOTES:

1. For applications requiring a TXV use 1TVM900 series kit.
2. Approved orifice shipped with outdoor unit.
3. Systems matched with furnace or air handlers not equipped with blower-off delays may require blower Time Delay Kit 2FD06700224.
4. PC coils cannot be used in downflow or horizontal applications. FC coils cannot be used in horizontal applications.

PROCEDURES:

1. Unit factory charge listed on the unit nameplate includes refrigerant for the condenser, the smallest evaporator and 15 feet of interconnecting line tubing.
2. Verify the TXV or orifice and additional charge required for specific evaporator coil in the system using the above table.
3. Additional charge for the amount of interconnecting line tubing greater than 15 feet at the rate specified in Physical and Electrical Data Table.
4. For TXV match charge weight needs to be weighed in for specific coil match and lineset length.
5. Permanently mark the unit nameplate with the total system charge. Total System Charge = Base Charge (as shipped) + adder for evaporator + adder for line set.



*F*FP Air Handlers come with a factory installed R-22 TXV which **MUST BE CHANGED OUT** to R-410A TXV or an orifice for proper operation. If the TXV is not changed out system damage will occur.*

COOLING CAPACITY - With Air Handler Coils

UNIT MODEL	AIR HANDLER		COIL MODEL ¹	COOLING				
	MODEL	W		RATED CFM	NET MBH		SEER	EER
					TOTAL	SENS.		
13 SEER HP WITH MA								
THGD18S41S1	MA08B	17	FC/MC/PC18B	600	17.0	12.6	13.00	11.00
	MA08B	17	FC/MC/PC24B	600	17.0	12.9	13.50	11.00
THGD24S41S1	MA08B	17	FC/MC/PC24B	800	23.0	17.1	13.00	11.00
	MA08B	17	FC/MC/PC30B	800	23.0	17.2	13.00	11.00
	MA08B	17	FC/MC/PC35B	800	23.0	17.5	13.00	11.00
THGD30S41S1	MA12B	17	FC/MC/PC35B	1000	29.0	23.2	13.00	11.00
	MA12B	17	FC/MC/PC43B	1000	29.0	23.4	13.00	11.00
THGD36S41S1	MA12B	17	FC/MC/PC43B	1200	35.0	26.8	13.00	11.00
	MA14D	24	FC/MC/PC48D	1200	35.0	27.0	13.00	11.00
THGD42S41S1	MA14D	24	FC/MC/PC48D	1400	41.5	31.4	13.00	11.00
	MA16C	21	FC/MC/PC48C	1400	41.5	31.4	13.00	11.00
	MA14D	24	FC/MC/PC60D	1400	41.0	31.2	13.00	11.00
	MA16C	21	FC/MC/PC60C	1400	41.0	31.2	13.00	11.00
THGD48S41S1	MA16C	21	FC/MC/PC48C	1600	47.0	35.2	13.00	11.00
	MA20D	24	FC/MC/PC48D	1600	47.0	35.2	13.00	11.00
	MA16C	21	FC/MC/PC60C	1600	47.0	35.6	13.00	11.00
	MA20D	24	FC/MC/PC60D	1600	47.0	35.6	13.00	11.00
	MA20D	24	MC62D	1600	47.0	35.6	13.00	11.00
THGD60S41S1	MA20D	24	MC62D	1800	54.0	42.5	13.00	11.00
13 SEER HP WITH MV - VARIABLE SPEED								
THGD18S41S1	MV12B	17	FC/MC/PC18B	600	17.0	12.9	14.00	12.00
	MV12B	17	FC/MC/PC24B	600	17.0	13.2	14.00	12.00
THGD24S41S1	MV12B	17	FC/MC/PC24B	800	23.0	17.6	14.00	12.00
	MV12B	17	FC/MC/PC30B	800	23.0	17.6	14.00	12.00
	MV12B	17	FC/MC/PC35B	800	23.0	17.9	14.00	12.00
	MV16C	21	FC/MC/PC35C	800	23.0	17.9	14.00	12.00
THGD30S41S1	MV12B	17	FC/MC/PC35B	1000	29.0	23.6	14.00	12.00
	MV16C	21	FC/MC/PC35C	1000	29.0	23.6	14.00	12.00
	MV12B	17	FC/MC/PC43B	1000	29.0	23.8	14.00	12.00
	MV16C	21	FC/MC/PC43C	1000	29.0	24.0	14.00	12.00
THGD36S41S1	MV12B	17	FC/MC/PC43B	1200	35.0	27.0	13.50	11.50
	MV16C	21	FC/MC/PC43C	1200	35.0	27.2	13.50	11.50
	MV12D	24	FC/MC/PC48D	1150	35.0	26.8	13.50	11.50
	MV16C	21	FC/MC/PC48C	1200	35.0	27.4	13.50	11.50
	MV20D	24	FC/MC/PC48D	1200	35.0	27.4	13.50	11.50
THGD42S41S1	MV16C	21	FC/MC/PC48C	1400	42.0	31.8	14.00	12.00
	MV20D	24	FC/MC/PC48D	1400	42.0	32.0	14.00	12.00
	MV20D	24	FC/MC/PC60D	1400	41.5	31.8	14.00	12.00
THGD48S41S1	MV16C	21	FC/MC/PC48C	1600	47.5	35.6	14.00	11.80
	MV20D	24	FC/MC/PC48D	1600	47.5	35.6	14.00	11.80
	MV20D	24	FC/MC/PC60D	1600	47.5	36.0	14.00	11.80
	MV20D	24	MC62D	1600	47.5	36.0	14.00	12.00
THGD60S41S1	MV20D	24	MC62D	1800	54.5	43.0	13.50	11.60

For Notes See Page 5.

COOLING CAPACITY - With Air Handler Coils (Continued)

UNIT MODEL	AIR HANDLER		COIL MODEL ¹	COOLING				
	MODEL	W		RATED CFM	NET MBH		SEER	EER
					TOTAL	SENS.		
13 SEER HP WITH AV / SV / F*FV - VARIABLE SPEED								
THGD18S41S1	AV24	17	—	550	17.0	13.0	14.00	12.00
THGD24S41S1	AV24	17	—	750	23.0	17.2	14.00	12.00
	AV36	21	—	750	23.0	18.0	14.00	12.00
THGD30S41S1	AV36	21	—	1000	29.0	24.4	14.00	12.00
THGD36S41S1	AV36	21	—	1250	35.0	28.0	13.50	11.50
THGD42S41S1	AV/SV48	24	—	1400	41.5	32.0	14.00	12.00
THGD48S41S1	AV/SV48	24	—	1600	47.5	36.2	14.00	11.80
	AV/SV60	24	—	1650	47.5	36.6	14.00	11.80
	F4FV060	24	—	1600	47.5	36.2	14.00	11.80
13 SEER HP WITH AHP / SHP / F*FP								
THGD18S41S1	AHP18	17	—	600	17.0	12.7	13.00	11.00
	F4FP024	17	—	600	17.0	12.6	13.00	11.00
THGD24S41S1	AHP30	17	—	800	23.0	17.2	13.00	11.00
	F4FP030	17	—	800	23.0	16.9	13.00	11.00
THGD30S41S1	AHP36	21	—	1000	29.0	23.2	13.00	11.00
	F4FP040	21	—	1000	29.0	22.6	13.00	11.00
THGD36S41S1	AHP36	21	—	1200	35.0	26.8	13.00	11.00
	F4FP045	24	—	1200	35.0	26.8	13.00	11.00
THGD42S41S1	AHP/SHP48	21	—	1400	41.5	31.4	13.00	11.00
	F4FP045	24	—	1400	41.0	31.2	13.00	11.00
	F5FP048	24	—	1450	41.0	32.6	13.00	11.00
THGD48S41S1	AHP/SHP60	24	—	1600	47.0	36.0	14.00	11.50
	F5FP048	24	—	1700	47.5	36.6	14.00	11.50
	F5FP060	24	—	1700	47.5	36.8	14.00	11.50
<p>Rated in accordance with DOE test procedures (Federal Register 12-27-79 and 3-18-88) and ARI Standards 210. Cooling MBH based on 80°F entering air temperature, 50% RH, and rated air flow. EER (Energy Efficiency Ratio) is the total cooling output in BTU's at 95°F outdoor ambient divided by the total electric power in watt-hours at those conditions. SEER (Seasonal Energy Efficiency Ratio) is the total cooling output in BTU's during a normal annual usage period for cooling divided by the total electric power input in watt-hours during the same period.</p>								

1. MC coils available with a factory installed horizontal drain pan. See price pages for specific model number.

— = Not applicable.

COOLING CAPACITY - Upflow, Downflow & Horizontal Furnaces and Coils

UNIT MODEL	FURNACE**		COIL MODEL	COOLING				
	CFM RANGE (Min.-max.)	W		RATED CFM	NET MBH		SEER ¹	EER
					TOTAL	SENS.		
THGD18S41S1	450 - 750	14,17	FC/MC/PC18	600	17.0	12.6	13.00	11.00
	450 - 750	14,17	FC/MC/PC24	600	17.0	12.9	13.50	11.00
	450 - 750	14	HC18	600	17.0	12.6	13.00	11.00
	450 - 750	14	HC30	600	17.0	12.8	13.00	11.00
	450 - 750	14	HD24	600	17.0	13.0	13.50	11.00
THGD24S41S1	600 - 1000	14,17	FC/MC/PC24	800	23.0	17.1	13.00	11.00
	600 - 1000	14,17	FC/MC/PC30	800	23.0	17.2	13.00	11.00
	600 - 1000	14	FC/MC/PC32	800	23.0	17.5	13.00	11.00
	600 - 1000	17,21	FC/MC/PC35	800	23.0	17.5	13.00	11.00
	600 - 1000	14	HC30	800	23.0	17.2	13.00	11.00
	600 - 1000	17	HC36	800	23.0	17.5	13.00	11.00
	600 - 1000	14,17	HD36	800	23.0	16.4	13.00	11.00
THGD30S41S1	800 - 1200	14	FC/MC/PC32	1000	29.0	23.2	13.00	11.00
	800 - 1200	17,21	FC/MC/PC35	1000	29.0	23.2	13.00	11.00
	800 - 1200	14	FC/MC/PC37	1000	29.0	23.4	13.00	11.00
	800 - 1200	17,21	FC/MC/PC43	1000	29.0	23.4	13.00	11.00
	800 - 1200	17	HC36	1000	29.0	23.2	13.00	11.00
	800 - 1200	21	HC42	1000	29.0	23.4	13.00	11.00
	800 - 1200	21,24	HD48	1000	29.0	23.4	13.00	11.00
THGD36S41S1	1000 - 1400	14	FC/MC/PC37	1200	35.0	26.6	13.00	11.00
	1000 - 1400	17,21	FC/MC/PC43	1200	35.0	26.8	13.00	11.00
	1000 - 1400	21,24	FC/MC/PC48	1200	35.0	27.0	13.00	11.00
	1000 - 1400	21	HC42	1200	35.0	26.8	13.00	11.00
	1000 - 1400	21,24	HD48	1200	35.0	26.8	13.00	11.00
THGD42S41S1	1200 - 1600	21,24	FC/MC/PC48	1400	41.5	31.4	13.00	11.00
	1200 - 1600	21,24	FC/MC/PC60	1400	41.0	31.2	13.00	11.00
	1200 - 1600	21	HC42	1400	41.0	31.2	13.00	11.00
	1200 - 1600	24	HC60	1400	41.0	31.2	13.00	11.00
	1200 - 1600	21,24	HD60	1400	41.5	31.4	13.00	11.00
THGD48S41S1	1400 - 1800	21,24	FC/MC/PC48	1600	47.0	35.2	13.00	11.00
	1400 - 1800	21,24	FC/MC/PC60	1600	47.0	35.6	13.00	11.00
	1400 - 1800	24	HC60	1600	47.0	35.6	13.00	11.00
	1400 - 1800	21,24	HD60	1600	47.0	35.4	13.00	11.00
	1400 - 1800	21,24	MC62	1600	47.0	35.6	13.00	11.00
THGD60S41S1	1600 - 2000	21,24	MC62	1800	54.0	42.5	13.00	11.00

1. Requires a 2FD06700224 Blower Time Delay unless a standard furnace is equipped with one.

** Refer to Quick Selection Chart for specific furnace match-up.

COOLING CAPACITY - With Variable Speed Furnaces

UNIT MODEL	VARIABLE SPEED FURNACE MODEL	COIL MODEL ¹	W	COOLING				
				RATED CFM	Net MBH		SEER	EER
					TOTAL	SENS.		
13 SEER HP WITH VARIABLE SPEED FURNACES²								
THGD18S41S1	PV8*A12	FC/MC/PC18A	14	600	17.0	12.9	14.00	12.00
	PV9*A12	FC/MC/PC18A	14	600	17.0	12.9	14.00	12.00
	P(C,V)9*B12	FC/MC/PC18B	17	600	17.0	12.9	14.00	12.00
	PV8*B16	FC/MC/PC/UC18B	17	600	17.0	12.9	14.00	12.00
	PV8*A12	FC/MC/PC24A	14	600	17.0	13.2	14.00	12.00
	PV9*A12	FC/MC/PC24A	14	600	17.0	13.2	14.00	12.00
	P(C,V)9*B12	FC/MC/PC24B	17	600	17.0	13.2	14.00	12.00
	PV8*B16	FC/MC/PC/UC24B	17	600	17.0	13.2	14.00	12.00
	PV8*A12	HC18A	14	600	17.0	12.9	14.00	12.00
	PV9*A12	HC18A	14	600	17.0	12.9	14.00	12.00
	PV8*A12	HC30A	14	600	17.0	13.2	14.00	12.00
	PV9*A12	HC30A	14	600	17.0	13.1	14.00	12.00
	PV8*A12	HD24A	14	600	17.0	13.3	14.00	12.00
	PV9*A12	HD24A	14	600	17.0	13.3	14.00	12.00
	P(C,V)9*B12	HD24	17	600	17.0	13.3	14.00	12.00
	PV8*B16	HD24	17	600	17.0	13.3	14.00	12.00
THGD24S41S1	PV8*A12	FC/MC/PC24A	14	750	23.0	17.1	14.00	12.00
	PV9*A12	FC/MC/PC24A	14	800	23.0	17.4	14.00	12.00
	P(C,V)9*B12	FC/MC/PC24B	17	800	23.0	17.5	14.00	12.00
	PV8*A12	FC/MC/PC30A	14	750	23.0	17.2	14.00	12.00
	PV9*A12	FC/MC/PC30A	14	800	23.0	17.5	14.00	12.00
	P(C,V)9*B12	FC/MC/PC30B	17	800	23.0	17.5	14.00	12.00
	PV8*A12	FC/MC/PC32A	14	750	23.0	17.4	14.00	12.00
	PV9*A12	FC/MC/PC32A	14	800	23.0	17.7	14.00	12.00
	P(C,V)9*B12	FC/MC/PC35B	17	800	23.0	17.8	14.00	12.00
	P(C,V)9*C16	FC/MC/PC35C	21	850	23.0	18.6	14.00	12.00
	PV8*A12	HC30A	14	750	23.0	17.2	14.00	12.00
	PV9*A12	HC30A	14	800	23.0	17.6	14.00	12.00
	P(C,V)9*B12	HC36B	17	800	23.0	17.8	14.00	12.00
	PV8*A12	HD36A	14	750	23.0	16.7	14.00	12.00
PV9*A12	HD36A	14	800	23.0	16.8	14.00	12.00	
P(C,V)9*B12	HD36B	17	800	23.0	16.8	14.00	12.00	
THGD30S41S1	PV8*A12	FC/MC/PC32A	14	1000	29.0	23.4	14.00	12.00
	PV9*A12	FC/MC/PC32A	14	1000	29.0	23.4	13.50	12.00
	PV8*B16	FC/MC/PC35B	17	1050	29.0	24.4	14.00	12.00
	PV8*C16	FC/MC/PC35C	21	1000	29.0	23.6	14.00	12.00
	PV8*C20	FC/MC/PC35C	21	1100	29.0	25.0	14.00	12.00
	P(C,V)9*B12	FC/MC/PC35B	17	1000	29.0	23.6	14.00	12.00
	P(C,V)9*C16	FC/MC/PC35C	21	1000	29.0	23.6	14.00	12.00
	P(C,V)9*C20	FC/MC/PC35C	21	1050	29.0	23.4	13.50	12.00
	PV8*A12	FC/MC/PC37A	14	1000	29.0	23.8	13.50	12.00
	PV9*A12	FC/MC/PC37A	14	1000	29.0	23.6	13.50	12.00
	PV8*B16	FC/MC/PC43B	17	1050	29.0	24.6	14.00	12.00
	PV8*C16	FC/MC/PC43C	21	1000	29.0	24.0	14.00	12.00
	PV8*C20	FC/MC/PC43C	21	1100	29.0	25.6	14.00	12.00
	P(C,V)9*B12	FC/MC/PC43B	17	1000	29.0	23.8	14.00	12.00
	P(C,V)9*C16	FC/MC/PC43C	21	1000	29.0	23.8	14.00	12.00
	P(C,V)9*C20	FC/MC/PC43C	21	1050	29.0	23.8	14.00	12.00
	PV8*B16	HC36B	17	1050	29.0	24.2	14.00	12.00
	P(C,V)9*B12	HC36B	17	1000	29.0	23.6	14.00	12.00

For Notes See Page 9.

COOLING CAPACITY - With Variable Speed Furnaces (Continued)

UNIT MODEL	VARIABLE SPEED FURNACE MODEL	COIL MODEL ¹	W	COOLING				
				RATED CFM	Net MBH		SEER	EER
					TOTAL	SENS.		
13 SEER HP WITH VARIABLE SPEED FURNACES²								
THGD30S41S1	PV8*C16	HC42C	21	1000	29.0	24.0	14.00	12.00
	PV8*C20	HC42C	21	1100	29.0	25.6	14.00	12.00
	P(C,V)9*C16	HC42C	21	1000	29.0	23.8	14.00	12.00
	P(C,V)9*C20	HC42C	21	1050	29.0	23.8	14.00	12.00
	PV8*C16	HD48C	21	1000	29.0	24.0	14.00	12.00
	PV8*C20	HD48C	21	1100	29.0	25.4	14.00	12.00
	P(C,V)9*C16	HD48C	21	1000	29.0	23.8	14.00	12.00
	P(C,V)9*C20	HD48C	21	1050	29.0	23.8	14.00	12.00
	P(C,V)9*D20	HD48D	24	1050	29.0	24.6	14.00	12.00
THGD36S41S1	PV8*A12	FC/MC/PC37A	14	1150	35.0	26.8	13.35	11.50
	PV9*A12	FC/MC/PC37A	14	1100	35.0	25.8	13.20	11.50
	PV8*B16	FC/MC/PC43B	17	1200	35.0	27.2	13.50	11.50
	PV8*C16	FC/MC/PC43C	21	1200	35.0	27.2	13.50	11.50
	PV8*C20	FC/MC/PC43C	21	1200	35.0	27.2	13.50	11.50
	P(C,V)9*B12	FC/MC/PC43B	17	1200	35.0	27.0	13.50	11.50
	P(C,V)9*C16	FC/MC/PC43C	21	1200	35.0	27.2	13.50	11.50
	P(C,V)9*C20	FC/MC/PC43C	21	1200	35.0	27.2	13.50	11.50
	PV8*C16	FC/MC/PC48C	21	1200	35.0	27.4	13.50	11.50
	PV8*C20	FC/MC/PC48C	21	1200	35.0	27.4	13.50	11.50
	P(C,V)9*C16	FC/MC/PC48C	21	1200	35.0	27.4	13.50	11.50
	P(C,V)9*C20	FC/MC/PC48C	21	1200	35.0	27.4	13.50	11.50
	P(C,V)9*D20	FC/MC/PC48D	24	1200	35.0	27.4	13.50	11.50
	PV8*C16	HC42C	21	1200	35.0	27.2	13.50	11.50
	PV8*C20	HC42C	21	1200	35.0	27.2	13.50	11.50
	P(C,V)9*C16	HC42C	21	1200	35.0	27.2	13.50	11.50
	P(C,V)9*C20	HC42C	21	1200	35.0	27.2	13.50	11.50
	PV8*C16	HD48C	21	1200	35.0	27.2	13.50	11.50
	PV8*C20	HD48C	21	1200	35.0	27.2	13.50	11.50
	P(C,V)9*C16	HD48C	21	1200	35.0	27.2	13.50	11.50
P(C,V)9*C20	HD48C	21	1200	35.0	27.2	13.50	11.50	
P(C,V)9*D20	HD48D	24	1200	35.0	27.2	13.50	11.50	
THGD42S41S1	PV8*C16	FC/MC/PC48C	21	1400	42.0	31.6	13.50	11.50
	PV8*C20	FC/MC/PC48C	21	1400	42.0	31.8	14.00	11.50
	P(C,V)9*C16	FC/MC/PC48C	21	1400	41.5	31.6	13.50	11.50
	P(C,V)9*C20	FC/MC/PC48C	21	1350	42.0	31.6	14.00	11.50
	P(C,V)9*D20	FC/MC/PC48D	24	1350	42.0	31.8	14.00	12.00
	PV8*C16	FC/MC/PC60C	21	1400	41.5	31.4	13.50	11.50
	PV8*C20	FC/MC/PC60C	21	1400	41.5	31.6	13.50	11.50
	P(C,V)9*C16	FC/MC/PC60C	21	1400	41.0	31.4	13.50	11.50
	P(C,V)9*C20	FC/MC/PC60C	21	1350	41.5	31.4	13.50	11.50
	P(C,V)9*D20	FC/MC/PC60D	24	1350	41.5	31.6	14.00	11.50
	PV8*C16	HC42C	21	1400	41.5	31.4	13.50	11.50
	PV8*C20	HC42C	21	1400	41.5	31.4	13.50	11.50
	P(C,V)9*C16	HC42C	21	1400	41.5	31.4	13.50	11.50
	P(C,V)9*C20	HC42C	21	1350	41.5	31.4	13.50	11.50
	P(C,V)9*D20	HC60D	24	1350	41.5	31.6	14.00	11.50
	PV8*C16	HD60C	21	1400	42.0	31.8	13.50	11.50
	PV8*C20	HD60C	21	1400	42.0	31.8	14.00	11.50
	P(C,V)9*C16	HD60C	21	1400	42.0	31.6	13.50	11.50
P(C,V)9*C20	HD60C	21	1350	42.0	31.8	14.00	11.50	
P(C,V)9*D20	HD60D	24	1350	42.0	31.8	14.00	12.00	

For Notes See Page 9.

COOLING CAPACITY - With Variable Speed Furnaces (Continued)

UNIT MODEL	VARIABLE SPEED FURNACE MODEL	COIL MODEL ¹	W	COOLING				
				RATED CFM	Net MBH		SEER	EER
					TOTAL	SENS.		
13 SEER HP WITH VARIABLE SPEED FURNACES²								
THGD48S41S1	PV8*C16	FC/MC/PC48C	21	1500	46.5	34.2	13.00	11.00
	PV8*C20	FC/MC/PC48C	21	1600	47.0	35.4	13.00	11.50
	P(C,V)9*C16	FC/MC/PC48C	21	1600	47.0	35.2	13.00	11.00
	P(C,V)9*C20	FC/MC/PC48C	21	1600	47.0	35.4	14.00	11.50
	P(C,V)9*D20	FC/MC/PC48D	24	1550	47.0	35.6	14.00	11.50
	PV8*C16	FC/MC/PC60C	21	1500	46.5	34.6	13.00	11.00
	PV8*C20	FC/MC/PC60C	21	1600	47.0	35.8	14.00	11.50
	P(C,V)9*C16	FC/MC/PC60C	21	1600	47.0	35.6	13.00	11.00
	P(C,V)9*C20	FC/MC/PC60C	21	1600	47.0	35.6	14.00	11.50
	P(C,V)9*D20	FC/MC/PC60D	24	1550	47.0	35.8	14.00	11.50
	P(C,V)9*D20	HC60D	24	1550	47.0	35.8	14.00	11.50
	PV8*C16	HD60C	21	1500	46.5	34.4	13.00	11.00
	PV8*C20	HD60C	21	1600	47.0	35.4	14.00	11.50
	P(C,V)9*C16	HD60C	21	1600	47.0	35.4	13.00	11.00
	P(C,V)9*C20	HD60C	21	1600	47.0	35.4	14.00	11.50
	P(C,V)9*D20	HD60D	24	1550	47.0	35.6	14.00	11.50
	PV8*C20	MC62C	21	1600	47.5	35.8	14.00	11.50
	P(C,V)9*C16	MC62C	21	1600	47.0	35.6	13.00	11.00
P(C,V)9*C20	MC62C	21	1600	47.0	35.8	14.00	11.50	
P(C,V)9*D20	MC62D	24	1550	47.5	36.0	14.00	11.80	
THGD60S41S1	PV8*C20	MC62C	21	1750	54.0	43.0	13.00	11.45
	P(C,V)9*C20	MC62C	21	1650	53.0	41.0	13.00	11.25
	P(C,V)9*D20	MC62D	24	1600	53.5	41.0	13.50	11.50

1. MC coils available with a factory installed horizontal drain pan. See price pages for specific model number.

2. Variable speed furnaces have B.O.D (Blower on Delay) standard.

HEATING PERFORMANCE - With Air Handler

UNIT MODEL*	AIR HANDLER	COIL ¹ MODEL	ARI HEATING ²						
			47°F			17°F			HSPF
			MBH	COP	KW	MBH	COP	KW	STD
13 SEER HP WITH MA									
THGD18S41S1	MA08B	FC/MC18B	17.0	3.32	1.50	12.7	3.00	1.24	7.70
	MA08B	FC/MC24B	17.0	3.44	1.45	10.4	2.60	1.17	7.70
THGD24S41S1	MA08B	FC/MC/PC24B	23.2	3.40	2.00	12.6	2.24	1.65	7.70
	MA08B	FC/MC/PC30B	23.2	3.40	2.00	12.6	2.24	1.65	7.70
	MA08B	FC/MC/PC35B	23.2	3.40	2.00	12.6	2.24	1.65	7.70
THGD30S41S1	MA12B	FC/MC/PC35B	28.0	3.34	2.46	16.4	2.30	2.09	7.70
	MA12B	FC/MC/PC43B	28.2	3.40	2.43	16.6	2.32	2.10	7.70
THGD36S41S1	MA12B	FC/MC/PC43B	35.0	3.42	3.00	21.2	2.36	2.63	8.00
	MA14D	FC/MC/PC48D	35.0	3.42	3.00	21.4	2.36	2.66	8.00
	MA16C	FC/MC43C	35.0	3.48	3.03	21.0	2.40	2.56	8.00
	MA16C	FC/MC48C	35.0	3.48	3.03	21.0	2.40	2.56	8.00
THGD42S41S1	MA14D	FC/MC/PC48D	41.0	3.48	3.45	28.0	2.46	3.34	8.00
	MA16C	FC/MC/PC48C	41.0	3.48	3.45	28.0	2.46	3.34	8.00
	MA14D	FC/MC/PC60D	41.0	3.66	3.28	27.8	2.56	3.18	8.00
	MA16C	FC/MC/PC60C	41.0	3.66	3.28	27.8	2.56	3.18	8.00
THGD48S41S1	MA16C	FC/MC/PC48C	50.5	3.32	4.46	30.8	2.24	4.03	8.00
	MA20D	FC/MC/PC48D	50.5	3.32	4.46	30.8	2.24	4.03	8.00
	MA16C	FC/MC/PC60C	51.0	3.50	4.27	30.6	2.34	3.83	8.00
	MA20D	FC/MC/PC60D	51.0	3.50	4.27	30.6	2.34	3.83	8.00
	MA20D	MC62D	50.5	3.38	4.38	30.6	2.28	3.93	8.00
THGD60S41S1	MA20D	MC62D	56.5	3.48	4.76	35.4	2.42	4.29	8.00
13 SEER HP WITH MV - VARIABLE SPEED									
THGD18S41S1	MV12B	FC/MC18B	16.7	3.52	1.39	12.7	3.00	1.24	8.00
	MV12B	FC/MC24B	17.0	3.66	1.36	9.8	2.78	1.03	8.00
THGD24S41S1	MV12B	FC/MC/PC24B	22.8	3.72	1.80	12.4	2.50	1.45	8.00
	MV12B	FC/MC/PC30B	22.8	3.72	1.80	12.4	2.50	1.45	8.00
	MV12B	FC/MC/PC35B	22.8	3.72	1.80	12.4	2.50	1.45	8.00
	MV16C	FC/MC/PC35C	22.8	3.72	1.80	12.4	2.50	1.45	8.00
THGD30S41S1	MV12B	FC/MC/PC35B	27.4	3.50	2.29	15.9	2.42	1.93	8.00
	MV16C	FC/MC/PC35C	27.4	3.52	2.28	15.9	2.42	1.93	8.00
	MV12B	FC/MC/PC43B	27.8	3.58	2.28	16.1	2.46	1.92	8.00
	MV16C	FC/MC/PC43C	27.6	3.60	2.25	16.1	2.48	1.90	8.00
THGD36S41S1	MV12B	FC/MC/PC43B	35.0	3.52	2.91	20.8	2.44	2.50	8.00
	MV16C	FC/MC/PC43C	35.0	3.58	2.87	20.6	2.48	2.43	8.00
	MV12D	FC/MC/PC48D	35.0	3.54	2.90	20.6	2.48	2.43	8.00
	MV16C	FC/MC/PC48C	35.0	3.60	2.85	20.6	2.50	2.42	8.00
	MV20D	FC/MC/PC48D	35.0	3.60	2.85	20.6	2.50	2.42	8.00
THGD42S41S1	MV16C	FC/MC/PC48C	41.0	3.60	3.34	27.4	2.54	3.16	8.00
	MV20D	FC/MC/PC48D	41.0	3.62	3.32	27.4	2.56	3.14	8.00
	MV20D	FC/MC/PC60D	41.0	3.84	3.13	27.0	2.68	2.95	8.00
THGD48S41S1	MV16C	FC/MC/PC48C	50.0	3.40	4.31	30.4	2.30	3.87	8.00
	MV20D	FC/MC/PC48D	50.0	3.38	4.34	30.4	2.28	3.91	8.00
	MV20D	FC/MC/PC60D	50.5	3.60	4.11	30.2	2.40	3.69	8.00
	MV20D	MC62D	50.0	3.48	4.21	30.0	2.34	3.76	8.00
THGD60S41S1	MV20D	MC62D	56.5	3.54	4.68	35.2	2.46	4.19	8.00

For Notes See Page 11.

HEATING PERFORMANCE - With Air Handler (Continued)

UNIT MODEL*	AIR HANDLER	COIL ¹ MODEL	ARI HEATING ²						
			47°F			17°F			HSPF
			MBH	COP	KW	MBH	COP	KW	STD
13 SEER HP WITH AV / SV / F*FV - VARIABLE SPEED									
THGD18S41S1	AV24	—	16.8	3.62	1.36	11.5	3.18	1.06	8.00
THGD24S41S1	AV24	—	22.4	3.72	1.76	12.4	2.50	1.45	8.00
	AV36	—	22.8	3.72	1.80	12.4	2.50	1.45	8.00
THGD30S41S1	AV36	—	27.6	3.64	2.22	16.0	2.50	1.88	8.00
THGD36S41S1	AV36	—	35.0	3.58	2.87	20.8	2.46	2.48	8.00
THGD42S41S1	AV/SV48	—	41.0	3.84	3.13	27.2	2.66	3.00	8.00
THGD48S41S1	AV/SV48	—	50.5	3.62	4.09	30.0	2.42	3.63	8.00
	AV/SV60	—	50.5	3.62	4.09	30.2	2.40	3.69	8.00
	F4FV060	—	50.5	3.62	4.09	30.2	2.40	3.69	8.00
13 SEER HP WITH AHP / SHP / F*FP									
THGD18S41S1	AHP18	—	17.0	3.38	1.47	8.2	2.16	1.11	7.70
	F4FP24	—	17.0	3.34	1.49	12.5	3.04	1.21	7.70
THGD24S41S1	AHP30	—	23.2	3.40	2.00	12.6	2.24	1.65	7.70
	F4FP030	—	23.2	3.40	2.00	12.6	2.24	1.65	7.70
THGD30S41S1	AHP36	—	28.2	3.40	2.43	16.6	2.32	2.10	7.70
	F4FP040	—	28.0	3.32	2.47	16.4	2.28	2.11	7.70
THGD36S41S1	AHP36	—	35.0	3.40	3.02	21.0	2.40	2.56	8.00
	F4FP045	—	35.0	3.40	3.02	21.6	2.42	2.62	8.00
THGD42S41S1	AHP/SHP48	—	41.0	3.32	3.62	28.2	2.36	3.50	8.00
	F4FP045	—	41.0	3.68	3.27	27.8	2.56	3.18	8.00
	F5FP048	—	41.0	3.68	3.27	27.6	2.58	3.14	8.00
THGD48S41S1	AHP/SHP60	—	50.5	3.58	4.13	30.2	2.40	3.69	8.00
	F5FP048	—	50.5	3.46	4.28	30.6	2.32	3.87	8.00
	F5FP060	—	50.5	3.60	4.11	30.2	2.40	3.69	8.00

1. Rated CFM same as for cooling.

2. Heating MBH based on ARI standards of 70° DB entering indoor air, 72% RH outdoor air with 25 feet of interconnecting piping and no supplemental electric heat operation.

CP equals MBH output divided by (total KW input x 3.412).

HSPF (Heating Seasonal Performance Factor) is the total heating output during a normal annual usage period for heating divided by the total electric power input during the same period.

— = Not Applicable.

HEATING PERFORMANCE - Upflow, Downflow, and Horizontal Furnaces and Coils

UNIT MODEL*	COIL ¹ MODEL	ARI HEATING ²						
		47°F			17°F			HSPF
		MBH	COP	KW	MBH	COP	KW	STD
THGD18S41S1	FC/MC/PC/UC1	17.0	3.32	1.50	12.7	3.00	1.24	7.70
	FC/MC/PC/UC2	17.0	3.44	1.45	10.4	2.60	1.17	7.70
	HC18	17.0	3.32	1.50	12.7	3.00	1.24	7.70
	HC30	17.0	3.38	1.47	10.4	2.60	1.17	7.70
	HD24	16.6	3.16	1.54	12.8	3.00	1.25	7.70
THGD24S41S1	FC/MC/PC24	23.2	3.40	2.00	12.6	2.24	1.65	7.70
	FC/MC/PC30	23.2	3.40	2.00	12.6	2.24	1.65	7.70
	FC/MC/PC32	23.2	3.40	2.00	12.6	2.24	1.65	7.70
	FC/MC/PC35	23.2	3.40	2.00	12.6	2.24	1.65	7.70
	HC30	23.0	3.40	1.98	12.6	2.24	1.65	7.70
	HC36	23.2	3.40	2.00	12.6	2.24	1.65	7.70
	HD36	23.2	3.40	2.00	12.6	2.24	1.65	7.70
THGD30S41S1	FC/MC/PC32	28.0	3.34	2.46	16.4	2.28	2.11	7.70
	FC/MC/PC35	28.0	3.34	2.46	16.4	2.30	2.09	7.70
	FC/MC/PC37	28.2	3.40	2.43	16.6	2.32	2.10	7.70
	FC/MC/PC43	28.2	3.40	2.43	16.6	2.32	2.10	7.70
	HC36	28.2	3.34	2.47	16.4	2.28	2.11	7.70
	HC42	28.2	3.40	2.43	16.6	2.32	2.10	7.70
	HD48	28.2	3.60	2.30	16.6	2.32	2.10	7.70
THGD36S41S1	FC/MC/PC37	35.0	3.40	3.02	21.2	2.36	2.63	8.00
	FC/MC/PC43	35.0	3.42	3.00	21.2	2.36	2.63	8.00
	FC/MC/PC48	35.0	3.42	3.00	21.4	2.36	2.66	8.00
	HC42	35.0	3.42	3.00	21.2	2.36	2.63	8.00
	HD48	35.0	3.40	3.02	20.0	2.16	2.71	8.00
THGD42S41S1	FC/MC/PC48	41.0	3.48	3.45	28.0	2.46	3.34	8.00
	FC/MC/PC60	41.0	3.66	3.28	27.8	2.56	3.18	8.00
	HC42	41.0	3.46	3.47	27.8	2.48	3.29	8.00
	HC60	41.0	3.66	3.28	27.8	2.56	3.18	8.00
	HD60	41.0	3.14	3.83	27.6	2.26	3.58	8.00
THGD48S41S1	FC/MC/PC48	50.5	3.32	4.46	30.8	2.24	4.03	8.00
	FC/MC/PC60	51.0	3.50	4.27	30.6	2.34	3.83	8.00
	HC60	51.0	3.50	4.27	30.6	2.34	3.83	8.00
	HD60	50.0	2.98	4.92	30.6	2.06	4.35	8.00
	MC62	50.5	3.38	4.38	30.6	2.28	3.93	8.00
THGD60S41S1	MC62	56.5	3.48	4.76	35.4	2.42	4.29	8.00

1. Rated CFM same as for cooling.

2. Heating MBH based on ARI standards of 70° DB entering indoor air, 72% RH outdoor air with 25 feet of interconnecting piping and no supplemental electric heat operation.

CP equals MBH output divided by (total KW input x 3.412).

HSPF (Heating Seasonal Performance Factor) is the total heating output during a normal annual usage period for heating divided by the total electric power input during the same period.

— = Not Applicable.

HEATING CAPACITY - With Variable Speed Furnaces

UNIT MODEL	VARIABLE SPEED FURNACE	COIL ¹ MODEL	ARI HEATING ²						
			47°F			17°F			HSPF
			MBH	COP	KW	MBH	COP	KW	STD
13 SEER HP WITH VARIABLE SPEED FURNACES³									
THGD18S41S1	PV8*A12	FC/MC/PC18A	16.7	3.56	1.37	11.5	3.12	1.08	8.00
	PV9*A12	FC/MC/PC18A	16.8	3.52	1.40	11.5	3.12	1.08	8.00
	P(C,V)9*B12	FC/MC/PC18B	16.7	3.52	1.39	11.5	3.12	1.08	8.00
	PV8*B16	FC/MC/PC18B	16.7	3.52	1.39	11.5	3.12	1.08	8.00
	PV8*A12	FC/MC/PC24A	17.0	3.68	1.35	9.7	2.80	1.02	8.00
	PV9*A12	FC/MC/PC24A	17.0	3.64	1.37	9.8	2.76	1.04	8.00
	P(C,V)9*B12	FC/MC/PC24B	17.0	3.66	1.36	9.8	2.78	1.03	8.00
	PV8*B16	FC/MC/PC24B	17.0	3.66	1.36	9.8	2.78	1.03	8.00
	PV8*A12	HC18A	16.7	3.56	1.37	11.5	3.12	1.08	8.00
	PV9*A12	HC18A	16.8	3.52	1.40	11.5	3.12	1.08	8.00
	PV8*A12	HC30A	17.0	3.62	1.38	9.7	2.78	1.02	8.00
	PV9*A12	HC30A	17.0	3.58	1.39	9.8	2.74	1.05	8.00
	PV8*A12	HD24A	16.2	3.38	1.40	12.0	3.20	1.10	8.00
	PV9*A12	HD24A	16.3	3.36	1.42	12.0	3.20	1.10	8.00
P(C,V)9*B12	HD24	16.3	3.36	1.42	12.0	3.20	1.10	8.00	
PV8*B16	HD24	16.3	3.36	1.42	12.0	3.20	1.10	8.00	
THGD24S41S1	PV8*A12	FC/MC/PC24A	22.6	3.72	1.78	12.4	2.50	1.45	8.00
	PV9*A12	FC/MC/PC24A	22.8	3.72	1.80	12.4	2.50	1.45	8.00
	P(C,V)9*B12	FC/MC/PC24B	22.8	3.72	1.80	12.4	2.50	1.45	8.00
	PV8*A12	FC/MC/PC30A	22.6	3.72	1.78	12.4	2.50	1.45	8.00
	PV9*A12	FC/MC/PC30A	22.8	3.72	1.80	12.4	2.50	1.45	8.00
	P(C,V)9*B12	FC/MC/PC30B	22.8	3.72	1.80	12.4	2.50	1.45	8.00
	PV8*A12	FC/MC/PC32A	22.6	3.72	1.78	12.4	2.50	1.45	8.00
	PV9*A12	FC/MC/PC32A	23.0	3.72	1.81	12.4	2.50	1.45	8.00
	P(C,V)9*B12	FC/MC/PC35B	22.8	3.72	1.80	12.4	2.50	1.45	8.00
	P(C,V)9*C16	FC/MC/PC35C	23.0	3.72	1.81	12.4	2.50	1.45	8.00
	PV8*A12	HC30A	22.4	3.72	1.76	12.4	2.50	1.45	8.00
	PV9*A12	HC30A	22.6	3.72	1.78	12.4	2.50	1.45	8.00
	P(C,V)9*B12	HC36B	22.8	3.72	1.80	12.4	2.50	1.45	8.00
	PV8*A12	HD36A	22.8	3.72	1.80	12.4	2.50	1.45	8.00
PV9*A12	HD36A	22.8	3.72	1.80	12.4	2.50	1.45	8.00	
P(C,V)9*B12	HD36B	22.8	3.72	1.80	12.4	2.50	1.45	8.00	
THGD30S41S1	PV8*A12	FC/MC/PC32A	27.6	3.48	2.32	16.0	2.40	1.95	8.00
	PV9*A12	FC/MC/PC32A	27.6	3.44	2.35	16.1	2.36	2.00	8.00
	PV8*B16	FC/MC/PC35B	27.6	3.54	2.29	16.0	2.44	1.92	8.00
	PV8*C16	FC/MC/PC35C	27.4	3.52	2.28	15.9	2.44	1.91	8.00
	PV8*C20	FC/MC/PC35C	27.8	3.56	2.29	16.2	2.44	1.95	8.00
	P(C,V)9*B12	FC/MC/PC35B	27.6	3.50	2.31	16.0	2.40	1.95	8.00
	P(C,V)9*C16	FC/MC/PC35C	27.6	3.50	2.31	16.0	2.40	1.95	8.00
	P(C,V)9*C20	FC/MC/PC35C	27.6	3.48	2.32	16.0	2.40	1.95	8.00
	PV8*A12	FC/MC/PC37A	28.0	3.50	2.34	16.3	2.40	1.99	8.00
	PV9*A12	FC/MC/PC37A	28.0	3.48	2.36	16.4	2.38	2.02	8.00
	PV8*B16	FC/MC/PC43B	27.8	3.62	2.25	16.2	2.48	1.91	8.00
	PV8*C16	FC/MC/PC43C	27.6	3.60	2.25	16.1	2.48	1.90	8.00
	PV8*C20	FC/MC/PC43C	28.2	3.68	2.25	16.3	2.50	1.91	8.00
	P(C,V)9*B12	FC/MC/PC43B	27.8	3.58	2.28	16.2	2.46	1.93	8.00
	P(C,V)9*C16	FC/MC/PC43C	27.8	3.58	2.28	16.2	2.46	1.93	8.00
	P(C,V)9*C20	FC/MC/PC43C	27.8	3.58	2.28	16.2	2.46	1.93	8.00
	PV8*B16	HC36B	27.6	3.54	2.29	16.0	2.44	1.92	8.00
	P(C,V)9*B12	HC36B	27.4	3.50	2.29	15.9	2.42	1.93	8.00
PV8*C16	HC42C	27.6	3.62	2.23	16.1	2.48	1.90	8.00	

For Notes See Page 15.

HEATING CAPACITY - With Variable Speed Furnaces (Continued)

UNIT MODEL	VARIABLE SPEED FURNACE	COIL ¹ MODEL	ARI HEATING ²						
			47°F			17°F			HSPF
			MBH	COP	KW	MBH	COP	KW	STD
THGD30S41S1	PV8*C20	HC42C	28.0	3.68	2.23	16.2	2.50	1.90	8.00
	P(C,V)9*C16	HC42C	27.8	3.58	2.28	16.2	2.46	1.93	8.00
	P(C,V)9*C20	HC42C	27.8	3.58	2.28	16.2	2.46	1.93	8.00
	PV8*C16	HD48C	28.0	3.68	2.23	16.2	4.76	1.00	8.00
	PV8*C20	HD48C	28.0	3.68	2.23	16.2	3.80	1.25	8.00
	P(C,V)9*C16	HD48C	28.0	3.68	2.23	16.2	4.70	1.01	8.00
	P(C,V)9*C20	HD48C	28.0	3.68	2.23	16.2	4.70	1.01	8.00
	P(C,V)9*D20	HD48D	28.0	3.68	2.23	16.2	3.72	1.28	8.00
THGD36S41S1	PV8*A12	FC/MC/PC37A	35.0	3.46	2.96	21.2	2.38	2.61	8.00
	PV9*A12	FC/MC/PC37A	35.0	3.40	3.02	21.0	2.38	2.59	8.00
	PV8*B16	FC/MC/PC43B	35.0	3.54	2.90	20.8	2.44	2.50	8.00
	PV8*C16	FC/MC/PC43C	35.0	3.56	2.88	20.8	2.46	2.48	8.00
	PV8*C20	FC/MC/PC43C	35.0	3.58	2.87	20.6	2.46	2.45	8.00
	P(C,V)9*B12	FC/MC/PC43B	35.0	3.48	2.95	21.0	2.40	2.56	8.00
	P(C,V)9*C16	FC/MC/PC43C	35.0	3.56	2.88	20.8	2.46	2.48	8.00
	P(C,V)9*C20	FC/MC/PC43C	35.0	3.54	2.90	20.8	2.44	2.50	8.00
	PV8*C16	FC/MC/PC48C	35.0	3.58	2.87	20.6	2.48	2.43	8.00
	PV8*C20	FC/MC/PC48C	35.0	3.58	2.87	20.6	2.48	2.43	8.00
	P(C,V)9*C16	FC/MC/PC48C	35.0	3.56	2.88	20.8	2.46	2.48	8.00
	P(C,V)9*C20	FC/MC/PC48C	35.0	3.56	2.88	20.8	2.46	2.48	8.00
	P(C,V)9*D20	FC/MC/PC48D	35.0	3.56	2.88	20.8	2.46	2.48	8.00
	PV8*C16	HC42C	35.0	3.56	2.88	20.8	2.46	2.48	8.00
	PV8*C20	HC42C	35.0	3.58	2.87	20.6	2.48	2.43	8.00
	P(C,V)9*C16	HC42C	35.0	3.56	2.88	20.8	2.46	2.48	8.00
	P(C,V)9*C20	HC42C	35.0	3.54	2.90	20.8	2.44	2.50	8.00
	PV8*C16	HD48C	35.0	3.40	3.02	19.4	2.26	2.52	8.00
	PV8*C20	HD48C	35.0	3.40	3.02	19.4	2.28	2.49	8.00
	P(C,V)9*C16	HD48C	35.0	3.40	3.02	19.5	2.24	2.55	8.00
P(C,V)9*C20	HD48C	35.0	3.40	3.02	19.5	2.24	2.55	8.00	
P(C,V)9*D20	HD48D	35.0	3.40	3.02	19.5	2.26	2.53	8.00	
THGD42S41S1	PV8*C16	FC/MC/PC48C	41.0	3.56	3.38	27.6	2.52	3.21	8.00
	PV8*C20	FC/MC/PC48C	41.0	3.58	3.36	27.6	2.52	3.21	8.00
	P(C,V)9*C16	FC/MC/PC48C	41.0	3.54	3.39	27.8	2.50	3.26	8.00
	P(C,V)9*C20	FC/MC/PC48C	41.0	3.56	3.38	27.6	2.52	3.21	8.00
	P(C,V)9*D20	FC/MC/PC48D	41.0	3.60	3.34	27.4	2.54	3.16	8.00
	PV8*C16	FC/MC/PC60C	41.0	3.76	3.20	27.4	2.62	3.07	8.00
	PV8*C20	FC/MC/PC60C	41.0	3.78	3.18	27.2	2.64	3.02	8.00
	P(C,V)9*C16	FC/MC/PC60C	41.0	3.72	3.23	27.4	2.60	3.09	8.00
	P(C,V)9*C20	FC/MC/PC60C	41.0	3.76	3.20	27.4	2.62	3.07	8.00
	P(C,V)9*D20	FC/MC/PC60D	41.0	3.80	3.16	27.2	2.66	3.00	8.00
	PV8*C16	HC42C	41.0	3.52	3.41	27.6	2.52	3.21	8.00
	PV8*C20	HC42C	41.0	3.54	3.39	27.4	2.54	3.16	8.00
	P(C,V)9*C16	HC42C	41.0	3.50	3.43	27.6	2.52	3.21	8.00
	P(C,V)9*C20	HC42C	41.0	3.54	3.39	27.4	2.54	3.16	8.00
	P(C,V)9*D20	HC60D	41.0	3.80	3.16	27.2	2.66	3.00	8.00
	PV8*C16	HD60C	41.0	3.20	3.76	27.2	2.30	3.47	8.00
	PV8*C20	HD60C	41.0	3.22	3.73	27.2	2.30	3.47	8.00
	P(C,V)9*C16	HD60C	41.0	3.18	3.78	27.4	2.28	3.52	8.00
	P(C,V)9*C20	HD60C	41.0	3.22	3.73	27.2	2.30	3.47	8.00
	P(C,V)9*D20	HD60D	41.0	3.24	3.71	27.0	2.32	3.41	8.00

For Notes See Page 15.

HEATING CAPACITY - With Variable Speed Furnaces (Continued)

UNIT MODEL	VARIABLE SPEED FURNACE	COIL ¹ MODEL	ARI HEATING ²						
			47°F			17°F			HSPF
			MBH	COP	KW	MBH	COP	KW	STD
THGD48S41S1	PV8*C16	FC/MC/PC48C	50.0	3.28	4.47	30.6	2.24	4.00	8.00
	PV8*C20	FC/MC/PC48C	50.5	3.34	4.43	30.6	2.26	3.97	8.00
	P(C,V)9*C16	FC/MC/PC48C	50.5	3.32	4.46	30.8	2.24	4.03	8.00
	P(C,V)9*C20	FC/MC/PC48C	50.5	3.34	4.43	30.6	2.26	3.97	8.00
	P(C,V)9*D20	FC/MC/PC48D	50.0	3.38	4.34	30.6	2.28	3.93	8.00
	PV8*C16	FC/MC/PC60C	50.5	3.50	4.23	30.4	2.34	3.81	8.00
	PV8*C20	FC/MC/PC60C	50.5	3.56	4.16	30.4	2.38	3.74	8.00
	P(C,V)9*C16	FC/MC/PC60C	51.0	3.52	4.25	30.6	2.34	3.83	8.00
	P(C,V)9*C20	FC/MC/PC60C	50.5	3.54	4.18	30.4	2.36	3.78	8.00
	P(C,V)9*D20	FC/MC/PC60D	50.5	3.58	4.13	30.2	2.38	3.72	8.00
	P(C,V)9*D20	HC60D	50.5	3.58	4.13	30.2	2.38	3.72	8.00
	PV8*C16	HD60C	49.5	2.94	4.93	30.4	2.04	4.37	8.00
	PV8*C20	HD60C	49.5	3.02	4.80	30.4	2.08	4.28	8.00
	P(C,V)9*C16	HD60C	50.0	2.98	4.92	30.6	2.06	4.35	8.00
	P(C,V)9*C20	HD60C	49.5	3.00	4.84	30.4	2.06	4.33	8.00
	P(C,V)9*D20	HD60D	49.5	3.04	4.77	30.2	2.08	4.26	8.00
	PV8*C20	MC62C	50.5	3.42	4.33	30.4	2.30	3.87	8.00
	P(C,V)9*C16	MC62C	50.5	3.38	4.38	30.6	2.28	3.93	8.00
	P(C,V)9*C20	MC62C	50.5	3.40	4.35	30.4	2.30	3.87	8.00
	P(C,V)9*D20	MC62D	50.0	3.44	4.26	30.2	2.32	3.82	8.00
THGD60S41S1	PV8*C20	MC62C	56.5	3.52	4.70	35.2	2.44	4.23	8.00
	P(C,V)9*C20	MC62C	56.5	3.44	4.81	35.2	2.42	4.26	8.00
	P(C,V)9*D20	MC62D	56.0	3.46	4.74	35.0	2.42	4.24	8.00

1. Rated CFM same as for cooling.

2. Heating MBH based on ARI standards of 70° DB entering indoor air, 72% RH outdoor air with 25 feet of interconnecting piping and no supplemental electric heat operation.

3. Variable speed furnaces have B.O.D (Blower on Delay) standard.

CP equals MBH output divided by (total KW input x 3.412).

HSPF (Heating Seasonal Performance Factor) is the total heating output during a normal annual usage period for heating divided by the total electric power input during the same period.

— = Not Applicable.

ACCESSORIES

Refer to Price Manual for specific model numbers.

Start Assist Kit (2SA067*) - May be required on 42, 48, 60 models. Models 18, 24, 30, 36 have been factory installed.

Blower Time Delay - Available to increase efficiency when installed. Installs on indoor section and maintains blower for approximately one minute after cooling thermostat has been satisfied.

Hard Start Kits - Provides required starting torque for use with Thermal Expansion Valve Kit.

Low Temperature Cutout (2LT06700224) - Prevents heat pump operation below -10°F ambient temperature.

Compressor Blanket - Designed to further reduce the normal operating sound.

Add-on Fossil Fuel Control - Interface controls for use with gas, oil furnaces and the heat pump system are available.

Thermal Expansion Valve Kit - 1TVM900 Series TXV kit used to improve system performance.

Outdoor Thermostat (2TD06700124) - Provides additional staging of supplemental electric heat.

Room Thermostats - A wide selection of matching thermostats is available to provide features required for any installation.

2H/1C, manual changeover electronic non-programmable thermostat.

3H/2C, non-programmable digital thermostat.

3H/2C, auto/manual changeover, electronic programmable, 7-day, hardwire thermostat.

* For the most current accessory information, refer to the price book or consult factory.

SOUND POWER RATINGS

UNIT MODEL	(dBA)*	
	Cooling	Heating
018	TBD	TBD
024	TBD	TBD
030	TBD	TBD
036	TBD	TBD
042	TBD	TBD
048	TBD	TBD
060	TBD	TBD

* Rated in accordance with ARI 270-95 Standards.

TYPICAL INSTALLATION

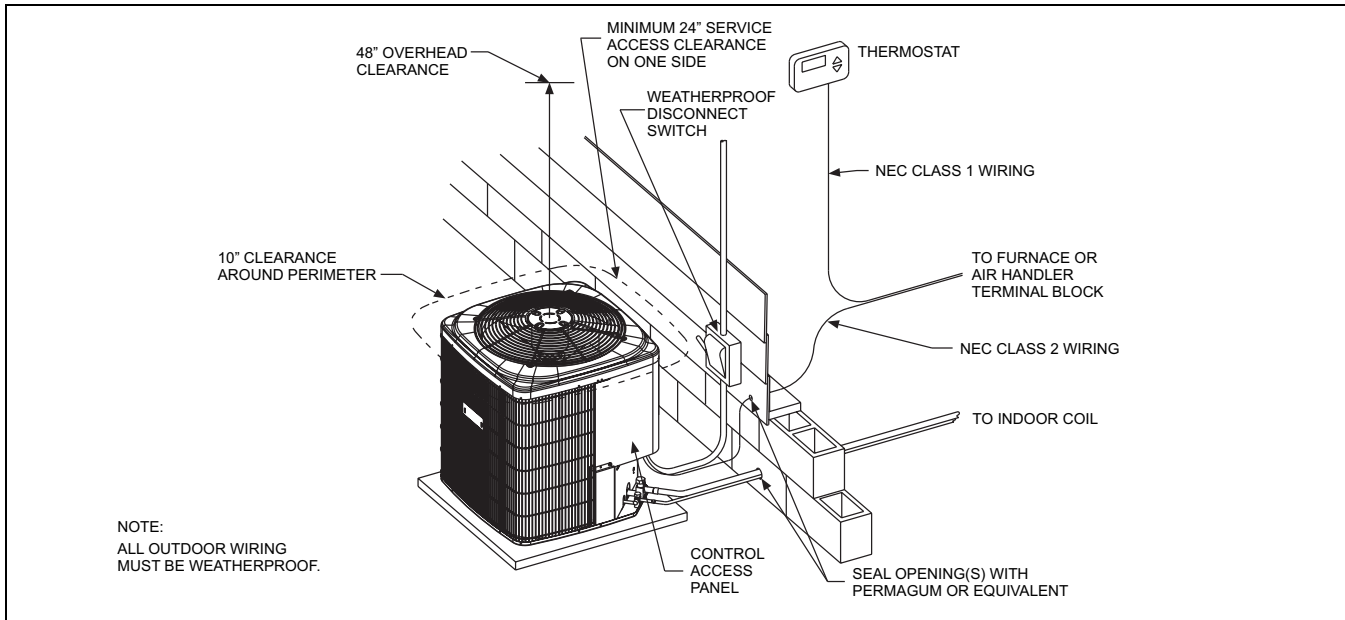

TYPICAL FIELD WIRING

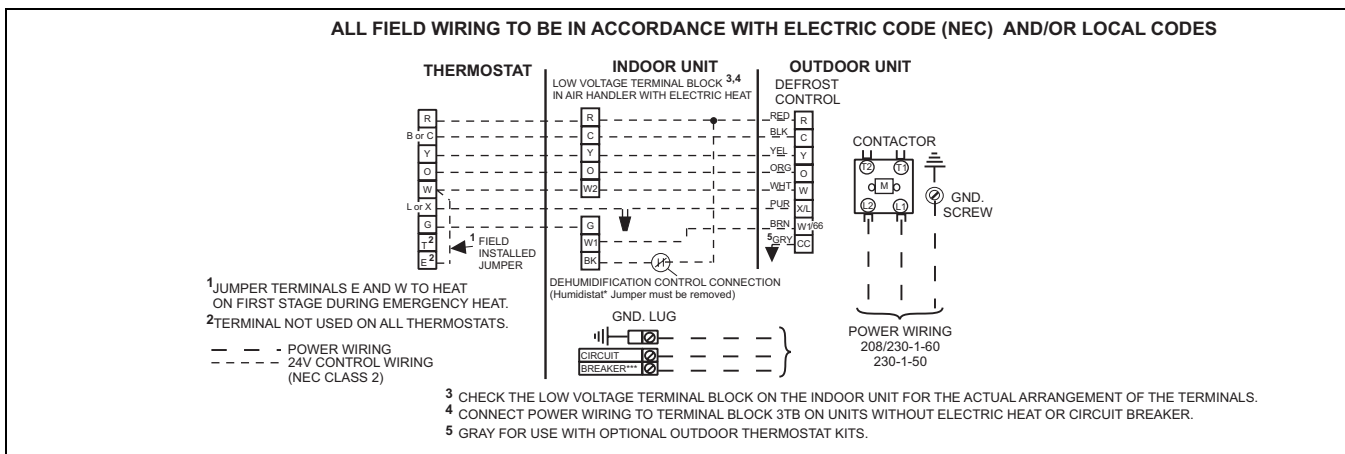

COOLING PERFORMANCE DATA																
CONDENSING UNIT MODEL NO.		THGD18S41S1														
INDOOR COIL MODEL NO.		AHP18														
CONDENSING ENTERING AIR TEMPERATURE	IDCFM	450					600					750				
	ID DB (°F)	80	80	75	80	80	80	80	75	80	80	80	80	75	80	80
	ID WB (°F)	57	62	62	67	72	57	62	62	67	72	57	62	62	67	72
65	T.C.	17.6	20.2	20.2	22.5	24.9	20.4	21.5	21.8	24.2	26.7	23.2	22.7	23.4	25.9	28.4
	S.C.	16.0	14.5	12.5	12.6	10.7	18.5	17.5	14.7	14.7	11.9	21.1	20.6	16.9	16.9	13.2
	KW	1.1	1.1	1.1	1.1	1.1	1.1	1.1	1.1	1.1	1.1	1.1	1.1	1.1	1.1	1.0
75	T.C.	16.6	18.6	18.6	20.7	23.0	19.1	19.9	19.9	22.1	24.6	21.6	21.2	21.2	23.6	26.1
	S.C.	15.0	13.8	11.8	11.9	10.0	17.3	16.5	14.0	14.0	11.2	19.6	19.3	16.1	16.1	12.4
	KW	1.2	1.2	1.2	1.2	1.2	1.2	1.2	1.2	1.2	1.2	1.2	1.2	1.2	1.2	1.2
85	T.C.	15.6	16.9	16.9	19.0	21.2	17.7	18.3	18.0	20.1	22.5	19.9	19.7	19.1	21.3	23.7
	S.C.	14.1	13.1	11.1	11.2	9.3	16.1	15.5	13.2	13.2	10.5	18.1	17.9	15.3	15.3	11.6
	KW	1.2	1.3	1.3	1.3	1.3	1.3	1.3	1.3	1.3	1.3	1.3	1.3	1.3	1.3	1.3
95	T.C.	14.5	15.3	15.3	17.2	19.3	16.4	16.8	16.1	18.1	20.3	18.3	18.3	16.9	19.0	21.4
	S.C.	13.2	12.4	10.4	10.5	8.6	14.9	14.5	12.4	12.5	9.7	16.6	16.6	14.5	14.5	10.8
	KW	1.3	1.3	1.3	1.4	1.4	1.4	1.4	1.4	1.4	1.4	1.4	1.4	1.4	1.4	1.4
105	T.C.	13.2	13.6	13.4	15.2	17.0	14.7	14.9	14.2	16.0	17.9	16.3	16.3	15.0	16.7	18.7
	S.C.	11.9	11.3	9.6	9.7	7.8	13.3	13.0	11.3	11.5	8.9	14.8	14.8	13.1	13.3	10.1
	KW	1.4	1.4	1.4	1.5	1.5	1.5	1.5	1.4	1.5	1.5	1.5	1.5	1.5	1.5	1.5
115	T.C.	11.8	12.0	11.5	13.2	14.8	13.1	13.1	12.3	13.9	15.5	14.3	14.3	13.2	14.5	16.1
	S.C.	10.7	10.4	8.9	9.0	7.1	11.9	11.7	10.3	10.6	8.2	13.0	13.0	11.7	12.3	9.3
	KW	1.5	1.5	1.5	1.5	1.6	1.5	1.6	1.5	1.6	1.6	1.6	1.6	1.6	1.6	1.6
125	T.C.	10.5	10.3	9.7	11.2	12.6	11.4	11.3	10.5	11.8	13.1	12.3	12.3	11.3	12.3	13.6
	S.C.	9.5	9.4	8.2	8.3	6.3	10.4	10.3	9.2	9.7	7.4	11.2	11.2	10.3	11.2	8.6
	KW	1.6	1.6	1.6	1.6	1.7	1.6	1.6	1.6	1.7	1.7	1.7	1.7	1.7	1.7	1.7

NOTE: ALL CAPACITIES INCLUDE INDOOR FAN HEAT AT 1250 BTUH/1000 CFM.

Multipliers for determining the performance with other indoor sections.

NOTE: For dry bulb temperatures different than those listed (between 73-87 F), sensible capacity increases by 1060 BTUH per 1000 CFM per degree above the listed temperature and decreases by 1060 BTUH per 1000 CFM per degree below the listed temperature.

Air Handler	Coil	T.C.	S.C.	KW
–	FC/MC/PC18	0.99	0.99	1.00
–	FC/MC/PC24	1.01	1.01	1.00
–	HC18	0.99	0.99	1.00
–	HC30	1.01	1.01	1.00
–	HD24	1.03	1.02	1.00
AHP18	–	0.97	0.96	1.00
AV24	–	1.03	1.02	1.00
F4FP024	–	1.00	0.99	1.00
MA08B	FC/MC/PC18B	0.99	0.99	1.00
MV12B	FC/MC/PC18B	1.02	1.01	1.00
MA08B	FC/MC/PC24B	1.01	1.01	1.00
MV12B	FC/MC/PC24B	1.04	1.04	1.00

Variable Speed Furnace	Coil	T.C.	S.C.	KW
PV8*A12	FC/MC/PC18A	1.02	1.02	1.00
PV9*A12	FC/MC/PC18A	1.02	1.01	1.00
P(C,V)9*B12	FC/MC/PC18B	1.02	1.01	1.00
PV8*B16	FC/MC/PC/UC18B	1.02	1.01	1.00
PV8*A12	FC/MC/PC24A	1.04	1.04	1.00
PV9*A12	FC/MC/PC24A	1.03	1.04	1.00
P(C,V)9*B12	FC/MC/PC24B	1.04	1.04	1.00
PV8*B16	FC/MC/PC/UC24B	1.04	1.04	1.00
PV8*A12	HC18A	1.02	1.02	1.00
PV9*A12	HC18A	1.02	1.01	1.00
PV8*A12	HC30A	1.03	1.04	1.00
PV9*A12	HC30A	1.03	1.03	1.00
PV8*A12	HD24A	1.06	1.05	1.00
PV9*A12	HD24A	1.05	1.05	1.00
P(C,V)9*B12	HD24	1.05	1.05	1.00
PV8*B16	HD24	1.05	1.05	1.00

COOLING PERFORMANCE DATA																
CONDENSING UNIT MODEL NO.		THGD24S41S1														
INDOOR COIL MODEL NO.		AHP30														
CONDENSING ENTERING AIR TEMPERATURE	IDCFM	600					800					1000				
	ID DB (°F)	80	80	75	80	80	80	80	75	80	80	80	80	75	80	80
	ID WB (°F)	57	62	62	67	72	57	62	62	67	72	57	62	62	67	72
65	T.C.	22.9	26.4	25.6	29.2	31.5	25.8	28.0	27.2	30.7	33.2	28.8	29.6	28.8	32.2	35.0
	S.C.	21.8	20.2	17.3	17.7	15.1	24.6	23.7	19.4	19.6	16.2	27.4	27.2	21.5	21.6	17.4
	KW	1.5	1.5	1.5	1.5	1.5	1.5	1.5	1.5	1.5	1.5	1.5	1.5	1.5	1.5	1.5
75	T.C.	21.9	24.6	24.1	27.3	29.5	24.5	26.0	25.5	28.6	31.1	27.0	27.4	26.9	30.0	32.6
	S.C.	20.8	19.4	16.5	16.8	14.3	23.3	22.4	18.6	18.8	15.4	25.7	25.4	20.7	20.8	16.5
	KW	1.6	1.6	1.6	1.6	1.6	1.6	1.6	1.6	1.6	1.6	1.6	1.6	1.6	1.6	1.6
85	T.C.	20.9	22.9	22.6	25.3	27.6	23.1	24.1	23.7	26.5	28.9	25.3	25.3	24.9	27.8	30.3
	S.C.	19.9	18.6	15.8	16.0	13.4	22.0	21.2	17.9	18.0	14.5	24.1	23.7	20.0	20.0	15.6
	KW	1.7	1.7	1.7	1.7	1.8	1.7	1.7	1.7	1.8	1.8	1.8	1.7	1.7	1.8	1.8
95	T.C.	19.8	21.1	21.0	23.4	25.6	21.7	22.1	22.0	24.5	26.8	23.5	23.1	23.0	25.6	27.9
	S.C.	18.9	17.8	15.0	15.1	12.6	20.6	19.9	17.1	17.2	13.7	22.4	22.0	19.2	19.2	14.8
	KW	1.8	1.8	1.8	1.9	1.9	1.9	1.9	1.9	1.9	1.9	1.9	1.9	1.9	1.9	1.9
105	T.C.	18.4	19.1	19.2	21.5	23.5	20.1	20.3	20.0	22.3	24.5	21.8	21.5	20.8	23.2	25.5
	S.C.	17.6	16.7	14.3	14.4	11.7	19.2	18.6	16.2	16.4	12.8	20.8	20.5	18.1	18.4	13.9
	KW	1.9	2.0	2.0	2.0	2.0	2.0	2.0	2.0	2.0	2.0	2.0	2.0	2.0	2.0	2.1
115	T.C.	17.1	17.3	17.4	19.6	21.5	18.6	18.6	18.0	20.2	22.3	20.1	20.0	18.7	20.9	23.1
	S.C.	16.3	15.7	13.5	13.6	10.8	17.7	17.4	15.2	15.6	12.0	19.2	19.1	16.9	17.6	13.1
	KW	2.1	2.1	2.1	2.1	2.2	2.1	2.1	2.1	2.1	2.2	2.2	2.2	2.1	2.2	2.2
125	T.C.	15.8	15.4	15.6	17.7	19.5	17.1	17.0	16.1	18.2	20.1	18.5	18.5	16.6	18.6	20.7
	S.C.	15.0	14.7	12.7	12.9	10.0	16.3	16.1	14.3	14.9	11.1	17.6	17.6	15.8	16.9	12.2
	KW	2.2	2.2	2.2	2.2	2.3	2.2	2.2	2.2	2.3	2.3	2.3	2.3	2.2	2.3	2.3

NOTE: ALL CAPACITIES INCLUDE INDOOR FAN HEAT AT 1250 BTUH/1000 CFM.

Multipliers for determining the performance with other indoor sections.

NOTE: For dry bulb temperatures different than those listed (between 73-87 F), sensible capacity increases by 1060 BTUH per 1000 CFM per degree above the listed temperature and decreases by 1060 BTUH per 1000 CFM per degree below the listed temperature.

Air Handler	Coil	T.C.	S.C.	KW
–	FC/MC/PC24	0.98	0.98	1.00
–	FC/MC/PC30	0.98	0.98	1.00
–	FC/MC/PC32	1.00	1.00	1.00
–	FC/MC/PC35	1.00	1.00	1.00
–	HC30	0.98	0.99	1.00
–	HC36	1.00	1.00	1.00
–	HD36	0.98	0.94	1.00
AHP30	–	0.99	0.98	1.00
AV24	–	0.99	0.98	1.00
AV36	–	1.03	1.03	1.00
F4FP030	–	0.99	0.97	1.00
MA08B	FC/MC/PC24B	0.98	0.98	1.00
MV12B	FC/MC/PC24B	1.01	1.00	1.00
MA08B	FC/MC/PC30B	0.98	0.98	1.00
MV12B	FC/MC/PC30B	1.01	1.01	1.00
MA08B	FC/MC/PC35B	1.00	1.00	1.00
MV12B	FC/MC/PC35B	1.02	1.02	1.00
MV16C	FC/MC/PC35C	1.02	1.02	1.00

Variable Speed Furnace	Coil	T.C.	S.C.	KW
PV8*A12	FC/MC/PC24A	1.00	0.98	1.00
PV9*A12	FC/MC/PC24A	1.00	1.00	1.00
P(C,V)9*B12	FC/MC/PC24B	1.00	1.00	1.00
PV8*A12	FC/MC/PC30A	1.00	0.98	1.00
PV9*A12	FC/MC/PC30A	1.00	1.00	1.00
P(C,V)9*B12	FC/MC/PC30B	1.00	1.00	1.00
PV8*A12	FC/MC/PC32A	1.01	1.00	1.00
PV9*A12	FC/MC/PC32A	1.01	1.01	1.00
P(C,V)9*B12	FC/MC/PC35B	1.02	1.02	1.00
P(C,V)9*C16	FC/MC/PC35C	1.03	1.06	1.00
PV8*A12	HC30A	1.00	0.99	1.00
PV9*A12	HC30A	1.00	1.00	1.00
P(C,V)9*B12	HC36B	1.02	1.02	1.00
PV8*A12	HD36A	0.99	0.95	1.00
PV9*A12	HD36A	1.00	0.96	1.00
P(C,V)9*B12	HD36B	1.00	0.96	1.00

COOLING PERFORMANCE DATA																
CONDENSING UNIT MODEL NO.		THGD30S41S1														
INDOOR COIL MODEL NO.		AHP36														
CONDENSING ENTERING AIR TEMPERATURE	IDCFM	800					1000					1200				
	ID DB (°F)	80	80	75	80	80	80	80	75	80	80	80	80	75	80	80
	ID WB (°F)	57	62	62	67	72	57	62	62	67	72	57	62	62	67	72
65	T.C.	28.5	30.9	31.1	34.0	37.0	30.8	32.4	32.4	35.6	38.7	33.1	33.9	33.7	37.2	40.5
	S.C.	28.7	26.1	22.3	22.1	18.6	31.1	29.7	24.5	24.4	19.8	33.4	33.4	26.8	26.7	21.1
	KW	1.7	1.8	1.8	1.8	1.7	1.7	1.8	1.8	1.7	1.7	1.7	1.8	1.8	1.7	1.7
75	T.C.	27.1	29.1	29.1	32.0	35.3	29.2	30.3	30.3	33.4	36.6	31.3	31.5	31.5	34.7	37.9
	S.C.	27.3	25.2	21.4	21.3	17.7	29.4	28.2	23.6	23.5	18.9	31.6	31.3	25.8	25.7	20.1
	KW	1.9	1.9	1.9	1.9	1.9	1.9	1.9	1.9	1.9	1.9	1.9	1.9	1.9	1.9	1.9
85	T.C.	25.7	27.2	27.2	30.0	33.6	27.6	28.2	28.2	31.2	34.5	29.5	29.2	29.2	32.3	35.4
	S.C.	25.9	24.3	20.5	20.4	16.8	27.8	26.7	22.7	22.6	17.9	29.8	29.2	24.8	24.7	19.1
	KW	2.0	2.1	2.1	2.1	2.1	2.1	2.1	2.1	2.1	2.1	2.1	2.1	2.1	2.1	2.1
95	T.C.	24.3	25.3	25.3	28.1	31.8	26.0	26.1	26.1	29.0	32.3	27.7	26.8	27.0	29.9	32.9
	S.C.	24.5	23.4	19.6	19.6	15.9	26.2	25.2	21.7	21.7	17.0	27.9	27.1	23.9	23.7	18.0
	KW	2.2	2.2	2.2	2.3	2.3	2.2	2.2	2.2	2.3	2.3	2.3	2.3	2.3	2.3	2.3
105	T.C.	22.6	23.3	23.0	25.7	29.1	24.1	24.2	23.7	26.4	29.6	25.6	25.1	24.4	27.2	30.1
	S.C.	22.8	22.1	18.6	18.6	14.9	24.3	23.7	20.5	20.7	16.0	25.9	25.3	22.4	22.7	17.1
	KW	2.4	2.4	2.4	2.4	2.5	2.4	2.4	2.4	2.4	2.5	2.4	2.4	2.4	2.5	2.5
115	T.C.	21.0	21.3	20.9	23.4	26.4	22.3	22.3	21.3	24.0	26.9	23.6	23.4	21.8	24.5	27.4
	S.C.	21.2	20.8	17.7	17.7	13.9	22.5	22.2	19.3	19.7	15.0	23.9	23.6	20.9	21.8	16.1
	KW	2.5	2.5	2.5	2.6	2.7	2.6	2.6	2.5	2.6	2.7	2.6	2.6	2.6	2.6	2.7
125	T.C.	19.4	19.3	18.7	21.1	23.7	20.5	20.5	19.0	21.5	24.2	21.6	21.6	19.3	21.9	24.7
	S.C.	19.6	19.5	16.7	16.8	12.9	20.7	20.7	18.1	18.8	14.1	21.9	21.9	19.5	20.8	15.2
	KW	2.7	2.7	2.7	2.8	2.8	2.7	2.7	2.7	2.8	2.9	2.8	2.8	2.7	2.8	2.9

NOTE: ALL CAPACITIES INCLUDE INDOOR FAN HEAT AT 1250 BTUH/1000 CFM.

Multipliers for determining the performance with other indoor sections.

NOTE: For dry bulb temperatures different than those listed (between 73-87 F), sensible capacity increases by 1060 BTUH per 1000 CFM per degree above the listed temperature and decreases by 1060 BTUH per 1000 CFM per degree below the listed temperature.

Air Handler	Coil	T.C.	S.C.	KW
–	FC/MC/PC32	0.99	0.99	1.00
–	FC/MC/PC35	0.99	0.99	1.00
–	FC/MC/PC37	1.01	1.01	1.00
–	FC/MC/PC43	1.01	1.01	1.00
–	HC36	0.99	0.99	1.00
–	HC42	1.01	1.01	1.00
–	HD48	1.01	1.01	1.00
AHP36	–	1.00	1.00	1.00
AV36	–	1.04	1.05	1.00
F4FP040	–	0.99	0.97	1.00
MA12B	FC/MC/PC35B	0.99	0.99	1.00
MV12B	FC/MC/PC35B	1.01	1.01	1.00
MV16C	FC/MC/PC35C	1.01	1.01	1.00
MA12B	FC/MC/PC43B	1.01	1.01	1.00
MV12B	FC/MC/PC43B	1.03	1.03	1.00
MV16C	FC/MC/PC43C	1.03	1.03	1.00

Variable Speed Furnace	Coil	T.C.	S.C.	KW
PV8*A12	FC/MC/PC32A	1.01	1.01	1.00
PV9*A12	FC/MC/PC32A	1.00	1.01	1.00
PV8*B16	FC/MC/PC35B	1.02	1.04	1.00
PV8*C16	FC/MC/PC35C	1.01	1.01	1.00
PV8*C20	FC/MC/PC35C	1.03	1.07	1.00
P(C,V)9*B12	FC/MC/PC35B	1.01	1.01	1.00
P(C,V)9*C16	FC/MC/PC35C	1.01	1.01	1.00
P(C,V)9*C20	FC/MC/PC35C	1.01	1.01	1.00
PV8*A12	FC/MC/PC37A	1.02	1.02	1.00
PV9*A12	FC/MC/PC37A	1.02	1.02	1.00
PV8*B16	FC/MC/PC43B	1.03	1.06	1.00
PV8*C16	FC/MC/PC43C	1.03	1.03	1.00
PV8*C20	FC/MC/PC43C	1.05	1.10	1.00
P(C,V)9*B12	FC/MC/PC43B	1.03	1.03	1.00
P(C,V)9*C16	FC/MC/PC43C	1.03	1.03	1.00
P(C,V)9*C20	FC/MC/PC43C	1.03	1.03	1.00
PV8*B16	HC36B	1.02	1.04	1.00
P(C,V)9*B12	HC36B	1.01	1.01	1.00
PV8*C16	HC42C	1.03	1.03	1.00
PV8*C20	HC42C	1.05	1.10	1.00
P(C,V)9*C16	HC42C	1.03	1.03	1.00
P(C,V)9*C20	HC42C	1.03	1.03	1.00
PV8*C16	HD48C	1.03	1.03	1.00
PV8*C20	HD48C	1.05	1.10	1.00
P(C,V)9*C16	HD48C	1.03	1.03	1.00
P(C,V)9*C20	HD48C	1.03	1.03	1.00
P(C,V)9*D20	HD48D	1.04	1.06	1.00

COOLING PERFORMANCE DATA																
CONDENSING UNIT MODEL NO.		THGD36S41S1														
INDOOR COIL MODEL NO.		AHP36														
CONDENSING ENTERING AIR TEMPERATURE	IDCFM	1000					1200					1400				
	ID DB (°F)	80	80	75	80	80	80	80	75	80	80	80	80	75	80	80
	ID WB (°F)	57	62	62	67	72	57	62	62	67	72	57	62	62	67	72
65	T.C.	37.0	40.3	39.8	43.7	47.3	39.3	41.5	41.2	45.3	48.9	41.6	42.6	42.7	46.8	50.5
	S.C.	35.7	32.2	27.3	27.6	23.6	37.9	35.0	29.4	29.4	24.6	40.2	37.8	31.4	31.3	25.6
	KW	2.2	2.2	2.2	2.1	2.2	2.2	2.2	2.2	2.1	2.2	2.1	2.2	2.2	2.2	2.2
75	T.C.	35.3	37.9	37.5	41.4	44.9	37.5	39.0	38.7	42.7	46.3	39.7	40.2	40.0	44.1	47.8
	S.C.	34.1	31.1	26.4	26.5	22.3	36.2	33.9	28.4	28.4	23.4	38.3	36.6	30.4	30.3	24.4
	KW	2.4	2.4	2.4	2.4	2.4	2.4	2.4	2.4	2.4	2.4	2.4	2.4	2.4	2.4	2.4
85	T.C.	33.7	35.4	35.2	39.0	42.4	35.7	36.6	36.2	40.2	43.7	37.7	37.8	37.3	41.4	45.1
	S.C.	32.5	30.1	25.4	25.5	21.1	34.5	32.7	27.4	27.4	22.2	36.4	35.4	29.3	29.2	23.2
	KW	2.6	2.6	2.6	2.6	2.6	2.6	2.6	2.6	2.6	2.6	2.6	2.6	2.6	2.6	2.6
95	T.C.	32.1	33.0	32.9	36.6	39.9	33.9	34.2	33.8	37.7	41.1	35.7	35.4	34.6	38.7	42.4
	S.C.	31.0	29.1	24.4	24.5	19.9	32.7	31.6	26.4	26.4	20.9	34.5	34.2	28.3	28.2	22.0
	KW	2.7	2.8	2.8	2.8	2.8	2.8	2.8	2.8	2.8	2.9	2.8	2.8	2.8	2.8	2.9
105	T.C.	29.9	30.2	30.2	33.6	36.9	31.6	31.6	30.9	34.5	38.0	33.2	32.9	31.6	35.5	39.0
	S.C.	28.9	27.4	23.3	23.3	18.7	30.5	29.6	25.2	25.2	19.7	32.0	31.8	27.1	27.0	20.7
	KW	2.9	3.0	3.0	3.0	3.1	3.0	3.0	3.0	3.0	3.1	3.0	3.0	3.0	3.0	3.1
115	T.C.	27.8	27.6	27.5	30.7	34.0	29.3	29.1	28.1	31.5	34.9	30.8	30.5	28.7	32.3	35.8
	S.C.	26.9	25.7	22.1	22.2	17.5	28.3	27.6	24.0	24.0	18.5	29.7	29.5	25.9	25.9	19.5
	KW	3.1	3.1	3.1	3.2	3.3	3.2	3.2	3.2	3.2	3.3	3.2	3.2	3.2	3.3	3.3
125	T.C.	25.7	25.0	24.8	27.8	31.1	27.0	26.6	25.3	28.4	31.8	28.3	28.1	25.8	29.1	32.6
	S.C.	24.8	24.1	21.0	21.0	16.4	26.1	25.6	22.9	22.9	17.4	27.3	27.2	24.7	24.7	18.4
	KW	3.3	3.3	3.3	3.4	3.5	3.4	3.4	3.3	3.4	3.5	3.4	3.4	3.4	3.5	3.6

NOTE: ALL CAPACITIES INCLUDE INDOOR FAN HEAT AT 1250 BTUH/1000 CFM.

Multipliers for determining the performance with other indoor sections.

NOTE: For dry bulb temperatures different than those listed (between 73-87 F), sensible capacity increases by 1060 BTUH per 1000 CFM per degree above the listed temperature and decreases by 1060 BTUH per 1000 CFM per degree below the listed temperature.

Air Handler	Coil	T.C.	S.C.	KW
-	FC/MC/PC37	1.00	0.99	1.00
-	FC/MC/PC43	0.99	0.99	1.00
-	FC/MC/PC48	1.00	1.00	1.00
-	HC42	0.99	0.99	1.00
-	HD48	1.00	1.00	1.00
-	HD48	0.97	0.96	1.00
AV36	-	1.02	1.04	1.00
F4FP045	-	1.00	1.00	1.00
MA12B	FC/MC/PC43B	0.99	0.99	1.00
MV12B	FC/MC/PC43B	1.01	1.01	1.00
MV16C	FC/MC/PC43C	1.01	1.01	1.00
MA14D	FC/MC/PC48D	1.00	1.00	1.00
MV12D	FC/MC/PC48D	1.01	1.00	1.00
MV16C	FC/MC/PC48C	1.03	1.02	1.00
MV20D	FC/MC/PC48D	1.03	1.02	1.00

Variable Speed Furnace	Coil	T.C.	S.C.	KW
PV8*A12	FC/MC/PC37A	1.00	1.00	1.00
PV9*A12	FC/MC/PC37A	0.99	0.96	1.00
PV8*B16	FC/MC/PC43B	1.01	1.01	1.00
PV8*C16	FC/MC/PC43C	1.01	1.01	1.00
PV8*C20	FC/MC/PC43C	1.01	1.01	1.00
P(C,V)9*B12	FC/MC/PC43B	1.00	1.00	1.00
P(C,V)9*C16	FC/MC/PC43C	1.01	1.01	1.00
P(C,V)9*C20	FC/MC/PC43C	1.01	1.01	1.00
PV8*C16	FC/MC/PC48C	1.02	1.02	1.00
PV8*C20	FC/MC/PC48C	1.02	1.02	1.00
P(C,V)9*C16	FC/MC/PC48C	1.02	1.02	1.00
P(C,V)9*C20	FC/MC/PC48C	1.02	1.02	1.00
P(C,V)9*D20	FC/MC/PC48D	1.02	1.02	1.00
PV8*C16	HC42C	1.01	1.01	1.00
PV8*C20	HC42C	1.01	1.01	1.00
P(C,V)9*C16	HC42C	1.01	1.01	1.00
P(C,V)9*C20	HC42C	1.01	1.01	1.00
PV8*C16	HD48C	1.02	1.01	1.00
PV8*C20	HD48C	1.02	1.02	1.00
P(C,V)9*C16	HD48C	1.01	1.01	1.00
P(C,V)9*C20	HD48C	1.01	1.01	1.00
P(C,V)9*D20	HD48D	1.02	1.01	1.00

COOLING PERFORMANCE DATA																
CONDENSING UNIT MODEL NO.		THGD42S41S1														
INDOOR COIL MODEL NO.		FC/MC/PC48														
CONDENSING ENTERING AIR TEMPERATURE	IDCFM	1200					1400					1600				
	ID DB (°F)	80	80	75	80	80	80	80	75	80	80	80	80	75	80	80
	ID WB (°F)	57	62	62	67	72	57	62	62	67	72	57	62	62	67	72
65	T.C.	39.7	42.2	42.3	46.6	50.3	41.4	43.0	43.0	47.1	51.6	43.2	43.9	43.7	47.7	52.9
	S.C.	41.5	37.8	32.1	32.0	25.7	43.3	41.1	34.2	33.9	27.1	45.1	44.5	36.3	35.8	28.4
	KW	2.4	2.4	2.5	2.5	2.4	2.4	2.4	2.5	2.5	2.4	2.5	2.5	2.4	2.5	2.5
75	T.C.	38.3	40.2	40.3	44.3	48.1	39.9	41.0	41.0	44.9	49.1	41.6	41.9	41.7	45.6	50.2
	S.C.	40.0	36.9	31.2	31.0	24.8	41.7	39.9	33.3	33.0	26.1	43.4	42.8	35.4	34.9	27.3
	KW	2.7	2.7	2.7	2.7	2.7	2.7	2.7	2.7	2.7	2.7	2.7	2.7	2.7	2.7	2.7
85	T.C.	36.9	38.2	38.2	41.9	45.8	38.4	39.0	39.0	42.7	46.7	40.0	39.9	39.7	43.5	47.5
	S.C.	38.5	36.0	30.2	30.0	23.9	40.2	38.6	32.3	32.0	25.1	41.8	41.2	34.5	34.1	26.2
	KW	2.9	3.0	3.0	3.0	3.0	3.0	3.0	3.0	3.0	3.0	3.0	3.0	3.0	3.0	3.0
95	T.C.	35.4	36.1	36.2	39.6	43.5	36.9	37.0	36.9	40.5	44.2	38.4	37.9	37.7	41.4	44.9
	S.C.	37.0	35.1	29.2	29.0	23.0	38.6	37.3	31.4	31.1	24.1	40.1	39.6	33.5	33.2	25.1
	KW	3.2	3.2	3.2	3.2	3.3	3.2	3.2	3.2	3.2	3.3	3.2	3.2	3.2	3.3	3.3
105	T.C.	33.2	33.7	33.4	36.7	40.2	34.5	34.6	34.1	37.4	40.8	35.9	35.5	34.8	38.1	41.4
	S.C.	34.7	33.4	28.0	27.8	21.7	36.1	35.3	30.1	29.8	22.8	37.5	37.1	32.3	31.9	23.8
	KW	3.6	3.6	3.6	3.6	3.7	3.6	3.6	3.6	3.6	3.7	3.6	3.6	3.6	3.7	3.7
115	T.C.	31.1	31.3	30.6	33.8	37.1	32.2	32.3	31.3	34.4	37.5	33.4	33.2	32.0	34.9	37.9
	S.C.	32.5	31.8	26.8	26.6	20.4	33.7	33.3	28.9	28.6	21.5	34.9	34.7	31.0	30.6	22.6
	KW	4.0	4.0	4.0	4.0	4.1	4.0	4.0	4.0	4.0	4.1	4.0	4.0	4.0	4.0	4.1
125	T.C.	28.9	28.9	27.9	31.0	33.9	29.9	29.9	28.5	31.4	34.2	30.9	30.9	29.2	31.7	34.5
	S.C.	30.2	30.2	25.5	25.4	19.1	31.3	31.3	27.7	27.4	20.2	32.3	32.3	29.8	29.4	21.3
	KW	4.5	4.4	4.4	4.4	4.5	4.4	4.4	4.4	4.4	4.5	4.4	4.4	4.4	4.4	4.5

NOTE: ALL CAPACITIES INCLUDE INDOOR FAN HEAT AT 1250 BTUH/1000 CFM.

Multipliers for determining the performance with other indoor sections.

NOTE: For dry bulb temperatures different than those listed (between 73-87 F), sensible capacity increases by 1060 BTUH per 1000 CFM per degree above the listed temperature and decreases by 1060 BTUH per 1000 CFM per degree below the listed temperature.

Air Handler	Coil	T.C.	S.C.	KW
–	FC/MC/PC60	0.99	0.99	1.00
–	HC42	1.00	0.99	1.00
–	HC60	0.99	0.99	1.00
–	HD60	1.01	1.00	1.00
AV48	–	1.01	1.02	1.00
F4FP045	–	0.99	1.00	1.00
F5FP048	–	1.02	1.04	1.00
AHP/SHP48	–	1.00	1.00	1.00
MA14D	FC/MC/PC48D	1.00	1.00	1.00
MA16C	FC/MC/PC48C	1.00	1.00	1.00
MV16C	FC/MC/PC48C	1.02	1.02	1.00
MV20D	FC/MC/PC48D	1.02	1.02	1.00
MA14D	FC/MC/PC60D	0.99	0.99	1.00
MA16C	FC/MC/PC60C	0.99	0.99	1.00
MV20D	FC/MC/PC60D	1.01	1.01	1.00

Variable Speed Furnace	Coil	T.C.	S.C.	KW
PV8*C16	FC/MC/PC48C	1.01	1.01	1.00
PV8*C20	FC/MC/PC48C	1.02	1.01	1.00
P(C,V)9*C16	FC/MC/PC48C	1.01	1.01	1.00
P(C,V)9*C20	FC/MC/PC48C	1.02	1.01	1.00
P(C,V)9*D20	FC/MC/PC48D	1.02	1.01	1.00
PV8*C16	FC/MC/PC60C	1.00	1.00	1.00
PV8*C20	FC/MC/PC60C	1.00	1.01	1.00
P(C,V)9*C16	FC/MC/PC60C	1.00	1.00	1.00
P(C,V)9*C20	FC/MC/PC60C	1.00	1.00	1.00
P(C,V)9*D20	FC/MC/PC60D	1.01	1.01	1.00
PV8*C16	HC42C	1.01	1.00	1.00
PV8*C20	HC42C	1.01	1.00	1.00
P(C,V)9*C16	HC42C	1.01	1.00	1.00
P(C,V)9*C20	HC42C	1.01	1.00	1.00
P(C,V)9*D20	HC60D	1.01	1.01	1.00
PV8*C16	HD60C	1.02	1.01	1.00
PV8*C20	HD60C	1.02	1.01	1.00
P(C,V)9*C16	HD60C	1.01	1.01	1.00
P(C,V)9*C20	HD60C	1.02	1.01	1.00
P(C,V)9*D20	HD60D	1.02	1.02	1.00

COOLING PERFORMANCE DATA																
CONDENSING UNIT MODEL NO.		THGD48S41S1														
INDOOR COIL MODEL NO.		AHP/SHP48														
CONDENSING ENTERING AIR TEMPERATURE	IDCFM	1400					1600					1800				
	ID DB (°F)	80	80	75	80	80	80	80	75	80	80	80	80	75	80	80
	ID WB (°F)	57	62	62	67	72	57	62	62	67	72	57	62	62	67	72
65	T.C.	46.3	49.0	49.0	53.3	57.3	48.3	49.9	49.7	54.0	58.4	50.2	50.8	50.4	54.8	59.4
	S.C.	47.3	43.0	36.2	35.8	29.6	49.3	45.5	37.9	37.6	30.7	51.3	48.0	39.6	39.4	31.8
	KW	2.5	2.5	2.5	2.5	2.5	2.5	2.5	2.5	2.5	2.5	2.5	2.5	2.5	2.5	2.5
75	T.C.	44.6	46.6	46.6	50.7	54.8	46.3	47.5	47.3	51.6	55.7	47.9	48.4	48.0	52.4	56.7
	S.C.	45.6	41.9	35.2	34.8	28.3	47.3	44.4	37.0	36.6	29.4	49.0	46.9	38.8	38.4	30.5
	KW	2.9	2.8	2.8	2.9	2.9	2.9	2.8	2.8	2.9	2.9	2.8	2.8	2.8	2.9	2.9
85	T.C.	42.9	44.1	44.2	48.2	52.2	44.3	45.0	44.9	49.1	53.1	45.7	45.9	45.7	50.0	54.0
	S.C.	43.8	40.9	34.3	33.8	27.1	45.2	43.3	36.1	35.7	28.1	46.7	45.7	38.0	37.5	29.1
	KW	3.2	3.2	3.2	3.2	3.2	3.2	3.2	3.2	3.2	3.2	3.2	3.2	3.2	3.2	3.2
95	T.C.	41.1	41.7	41.7	45.7	49.7	42.3	42.6	42.5	46.6	50.5	43.4	43.5	43.3	47.5	51.3
	S.C.	42.0	39.8	33.3	32.8	25.8	43.2	42.2	35.2	34.7	26.8	44.3	44.5	37.2	36.6	27.8
	KW	3.5	3.5	3.5	3.6	3.6	3.5	3.5	3.5	3.6	3.6	3.5	3.5	3.5	3.6	3.6
105	T.C.	38.8	38.7	38.7	42.4	46.4	39.8	39.8	39.4	43.2	47.0	40.9	40.8	40.0	43.9	47.6
	S.C.	39.6	37.7	32.0	31.6	24.6	40.7	39.7	33.9	33.5	25.6	41.8	41.7	35.9	35.3	26.6
	KW	4.0	4.0	4.0	4.0	4.0	4.0	4.0	4.0	4.0	4.0	4.0	4.0	4.0	4.0	4.0
115	T.C.	36.4	35.9	35.9	39.3	43.3	37.5	37.0	36.3	39.8	43.7	38.5	38.1	36.8	40.4	44.1
	S.C.	37.2	35.7	30.7	30.4	23.4	38.3	37.3	32.7	32.2	24.3	39.3	38.9	34.6	34.1	25.3
	KW	4.4	4.4	4.4	4.4	4.5	4.4	4.4	4.4	4.4	4.5	4.4	4.4	4.4	4.4	4.5
125	T.C.	34.1	33.0	33.0	36.1	40.1	35.1	34.2	33.3	36.5	40.4	36.0	35.4	33.6	36.9	40.6
	S.C.	34.9	33.7	29.5	29.2	22.1	35.9	34.9	31.4	31.0	23.1	36.8	36.1	33.3	32.9	24.1
	KW	4.8	4.8	4.8	4.8	4.9	4.8	4.8	4.8	4.9	4.9	4.8	4.8	4.8	4.9	4.9

NOTE: ALL CAPACITIES INCLUDE INDOOR FAN HEAT AT 1250 BTUH/1000 CFM.

Multipliers for determining the performance with other indoor sections.

NOTE: For dry bulb temperatures different than those listed (between 73-87 F), sensible capacity increases by 1060 BTUH per 1000 CFM per degree above the listed temperature and decreases by 1060 BTUH per 1000 CFM per degree below the listed temperature.

Air Handler	Coil	T.C.	S.C.	KW
–	FC/MC/PC48	1.00	1.01	1.00
–	FC/MC/PC60	1.00	1.02	1.00
–	HC60	1.00	1.02	1.00
–	HD60	1.00	1.01	1.00
–	MC62	1.01	1.02	1.00
AHP60	–	1.01	1.03	1.00
AV48	–	1.02	1.03	1.00
AV60	–	1.02	1.05	1.00
F4FV060	–	1.02	1.03	1.00
F5FP048	–	1.02	1.05	1.00
F5FP060	–	1.02	1.05	1.00
MA16C	FC/MC/PC48C	1.00	1.01	1.00
MA20D	FC/MC/PC48D	1.00	1.01	1.00
MV16C	FC/MC/PC48C	1.02	1.02	1.00
MV20D	FC/MC/PC48D	1.01	1.02	1.00
MA16C	FC/MC/PC60C	1.00	1.02	1.00
MA20D	FC/MC/PC60D	1.00	1.02	1.00
MV20D	FC/MC/PC60D	1.01	1.03	1.00
MA20D	MC62D	1.01	1.02	1.00
MV20D	MC62D	1.02	1.03	1.00

Variable Speed Furnace	Coil	T.C.	S.C.	KW
PV8*C16	FC/MC/PC48C	1.00	0.98	1.00
PV8*C20	FC/MC/PC48C	1.01	1.01	1.00
P(C,V)9*C16	FC/MC/PC48C	1.00	1.01	1.00
P(C,V)9*C20	FC/MC/PC48C	1.01	1.01	1.00
P(C,V)9*D20	FC/MC/PC48D	1.01	1.02	1.00
PV8*C16	FC/MC/PC60C	1.00	0.99	1.00
PV8*C20	FC/MC/PC60C	1.01	1.02	1.00
P(C,V)9*C16	FC/MC/PC60C	1.00	1.02	1.00
P(C,V)9*C20	FC/MC/PC60C	1.01	1.02	1.00
P(C,V)9*D20	FC/MC/PC60D	1.01	1.02	1.00
P(C,V)9*D20	HC60D	1.01	1.02	1.00
PV8*C16	HD60C	1.00	0.98	1.00
PV8*C20	HD60C	1.01	1.01	1.00
P(C,V)9*C16	HD60C	1.00	1.01	1.00
P(C,V)9*C20	HD60C	1.01	1.01	1.00
P(C,V)9*D20	HD60D	1.01	1.02	1.00
PV8*C20	MC62C	1.01	1.02	1.00
P(C,V)9*C16	MC62C	1.01	1.02	1.00
P(C,V)9*C20	MC62C	1.01	1.02	1.00
P(C,V)9*D20	MC62D	1.02	1.03	1.00

COOLING PERFORMANCE DATA																
CONDENSING UNIT MODEL NO.		THGD60S41S1														
INDOOR COIL MODEL NO.		FC/MC62														
CONDENSING ENTERING AIR TEMPERATURE	IDCFM	1400					1600					1800				
	ID DB (°F)	80	80	75	80	80	80	80	75	80	80	80	80	75	80	80
	ID WB (°F)	57	62	62	67	72	57	62	62	67	72	57	62	62	67	72
65	T.C.	54.0	57.1	56.9	62.3	67.6	56.0	57.9	57.8	63.4	69.1	58.0	58.7	58.7	64.4	70.5
	S.C.	56.0	51.0	43.4	42.9	34.8	58.1	54.4	45.4	45.0	36.2	60.1	57.7	47.4	47.1	37.6
	KW	2.8	2.8	2.8	2.9	2.9	2.8	2.8	2.8	2.9	2.9	2.8	2.8	2.8	2.9	2.9
75	T.C.	51.9	54.1	53.9	59.2	64.5	53.7	54.9	54.8	60.2	65.7	55.5	55.7	55.6	61.2	66.9
	S.C.	53.8	49.8	42.0	41.7	33.5	55.7	52.7	44.1	43.8	34.8	57.5	55.6	46.1	45.8	36.2
	KW	3.2	3.2	3.2	3.3	3.3	3.2	3.2	3.2	3.3	3.3	3.2	3.2	3.2	3.3	3.3
85	T.C.	49.7	51.1	51.0	56.2	61.4	51.3	51.9	51.8	57.1	62.4	53.0	52.7	52.6	58.0	63.4
	S.C.	51.6	48.6	40.7	40.5	32.2	53.2	51.1	42.8	42.5	33.4	54.9	53.6	44.9	44.6	34.7
	KW	3.6	3.6	3.6	3.6	3.7	3.6	3.6	3.6	3.7	3.7	3.6	3.6	3.6	3.7	3.7
95	T.C.	47.6	48.1	48.1	53.1	58.3	49.0	48.9	48.8	54.0	59.0	50.4	49.7	49.5	54.8	59.8
	S.C.	49.4	47.4	39.3	39.2	30.9	50.8	49.5	41.5	41.3	32.0	52.3	51.5	43.6	43.3	33.2
	KW	4.0	4.0	4.0	4.0	4.1	4.0	4.0	4.0	4.1	4.1	4.0	4.0	4.0	4.1	4.1
105	T.C.	44.3	44.6	44.1	48.7	53.5	45.6	45.5	44.6	49.3	54.1	46.8	46.3	45.2	50.0	54.7
	S.C.	45.9	44.7	37.6	37.4	29.0	47.2	46.3	39.7	39.4	30.2	48.5	48.0	41.8	41.5	31.3
	KW	4.5	4.5	4.5	4.5	4.6	4.5	4.5	4.5	4.5	4.6	4.5	4.5	4.5	4.5	4.6
115	T.C.	41.1	41.3	40.2	44.4	48.9	42.2	42.2	40.6	44.9	49.4	43.3	43.1	41.0	45.3	49.9
	S.C.	42.6	42.0	35.9	35.7	27.3	43.8	43.3	37.9	37.7	28.4	44.9	44.6	40.0	39.7	29.5
	KW	4.9	5.0	4.9	5.0	5.0	5.0	5.0	4.9	5.0	5.0	5.0	5.0	5.0	5.0	5.0
125	T.C.	37.9	37.9	36.2	40.1	44.3	38.8	38.8	36.5	40.4	44.6	39.8	39.8	36.8	40.7	45.0
	S.C.	39.3	39.3	34.2	33.9	25.5	40.3	40.3	36.2	35.9	26.6	41.2	41.3	38.2	37.9	27.7
	KW	5.4	5.4	5.4	5.4	5.5	5.4	5.4	5.4	5.4	5.5	5.4	5.4	5.4	5.4	5.5

NOTE: ALL CAPACITIES INCLUDE INDOOR FAN HEAT AT 1250 BTUH/1000 CFM.

Multipliers for determining the performance with other indoor sections.

NOTE: For dry bulb temperatures different than those listed (between 73-87 F), sensible capacity increases by 1060 BTUH per 1000 CFM per degree above the listed temperature and decreases by 1060 BTUH per 1000 CFM per degree below the listed temperature.

Air Handler	Coil	T.C.	S.C.	KW
MA20D	MC62D	1.00	1.00	1.00
MV20D	MC62D	1.01	1.01	1.00

Variable Speed Furnace	Coil	T.C.	S.C.	KW
PV8°C20	MC62C	1.00	1.00	1.00
P(C,V)9°C20	MC62C	0.98	0.96	1.00
P(C,V)9°D20	MC62D	0.99	0.96	1.00

HEATING PERFORMANCE DATA										
CONDENSING UNIT MODEL NO		THGD18S41S1								
EVAPORATOR COIL MODEL NO		AHP18								
AIR TEMP. ENTERING OUTDOOR UNIT	AIR TEMP. ENTERING INDOOR COIL	ID CFM								
		450			600			750		
		MBTUH	KW	C.O.P.	MBTUH	KW	C.O.P.	MBTUH	KW	C.O.P.
60	60	19.7	1.6	3.7	21.0	1.6	3.9	22.3	1.6	4.2
	70	18.3	1.6	3.3	19.6	1.6	3.5	20.9	1.6	3.8
	80	16.8	1.7	2.9	18.1	1.7	3.2	19.5	1.7	3.4
47	60	16.4	1.5	3.3	17.6	1.5	3.5	18.8	1.5	3.7
	70	15.2	1.5	3.0	16.4	1.5	3.2	17.6	1.5	3.3
	80	14.0	1.5	2.7	15.2	1.6	2.8	16.4	1.6	3.0
40	60	14.9	1.4	3.1	16.2	1.4	3.3	17.5	1.5	3.5
	70	12.4	1.4	2.5	14.3	1.5	2.9	16.3	1.5	3.2
	80	9.9	1.5	2.0	12.5	1.5	2.4	15.0	1.6	2.8
30	60	10.3	1.3	2.2	11.5	1.4	2.4	12.7	1.5	2.5
	70	11.5	1.3	2.5	12.7	1.4	2.7	14.0	1.4	2.9
	80	12.6	1.3	2.8	13.9	1.4	3.0	15.2	1.4	3.2
17	60	7.6	1.2	1.9	7.8	1.3	1.8	7.9	1.4	1.7
	70	8.2	1.2	2.0	8.5	1.3	2.0	8.8	1.3	2.0
	80	8.8	1.2	2.2	9.2	1.2	2.2	9.7	1.3	2.2
10	60	6.1	1.1	1.6	6.7	1.2	1.6	7.3	1.3	1.7
	70	6.2	1.1	1.6	7.1	1.2	1.7	8.0	1.3	1.8
	80	6.2	1.1	1.6	7.4	1.2	1.8	8.6	1.3	2.0

NOTE: ALL CAPACITIES ARE NET (KBTUH) WITH INDOOR FAN HEAT ALREADY DEDUCTED AT 1250 BTUH/1000 CFM.

Multipliers for determining the performance with other indoor sections.

Air Handler	Coil	MBH	KW	COP
-	FC/MC/PC18	1.00	1.00	1.00
-	FC/MC/PC24	1.03	1.04	0.99
-	HC18	1.00	1.00	1.00
-	HC30	1.02	1.02	0.99
-	HD24	0.97	0.96	1.02
AHP18	-	1.02	1.02	1.00
AV24	-	0.98	0.99	1.00
F4FP024	-	1.01	1.01	1.00
MV12B	FC/MC/PC18B	0.98	0.98	1.00
MA08B	FC/MC/PC18B	1.00	1.00	1.00
MA08B	FC/MC/PC24B	1.03	1.04	0.99
MV12B	FC/MC/PC24B	1.00	1.02	0.99

Variable Speed Furnace	Coil	MBH	KW	COP
PV8*A12	FC/MC/PC18A	0.98	0.98	1.00
PV9*A12	FC/MC/PC18A	0.98	0.98	1.00
P(C,V)9*B12	FC/MC/PC18B	0.98	0.98	1.00
PV8*B16	FC/MC/PC18B	0.98	0.98	1.00
PV8*A12	FC/MC/PC24A	1.00	1.02	0.99
PV9*A12	FC/MC/PC24A	1.01	1.02	0.99
P(C,V)9*B12	FC/MC/PC24B	1.00	1.02	0.99
PV8*B16	FC/MC/PC24B	1.00	1.02	0.99
PV8*A12	HC18A	0.98	0.98	1.00
PV9*A12	HC18A	0.98	0.98	1.00
PV8*A12	HC30A	0.99	1.00	0.99
PV9*A12	HC30A	1.00	1.00	0.99
PV8*A12	HD24A	0.95	0.93	1.02
PV9*A12	HD24A	0.95	0.94	1.02
P(C,V)9*B12	HD24	0.95	0.94	1.02
PV8*B16	HD24	0.95	0.94	1.02

HEATING PERFORMANCE DATA										
CONDENSING UNIT MODEL NO		THGD24S41S1								
EVAPORATOR COIL MODEL NO		AHP24								
AIR TEMP. ENTERING OUTDOOR UNIT	AIR TEMP. ENTERING INDOOR COIL	ID CFM								
		600			800			1000		
		MBTUH	KW	C.O.P.	MBTUH	KW	C.O.P.	MBTUH	KW	C.O.P.
60	60	28.4	2.1	4.0	30.1	2.0	4.3	31.8	2.0	4.6
	70	26.7	2.2	3.6	28.4	2.2	3.9	30.1	2.1	4.1
	80	25.1	2.3	3.2	26.8	2.3	3.5	28.5	2.2	3.7
47	60	23.4	1.9	3.5	24.5	1.9	3.7	25.7	1.9	3.9
	70	22.0	2.0	3.2	22.2	2.0	3.3	22.4	2.0	3.3
	80	20.6	2.1	2.9	19.9	2.0	2.9	19.1	2.0	2.8
40	60	20.7	1.9	3.2	21.9	1.9	3.4	23.1	1.9	3.5
	70	19.3	1.9	2.9	20.4	2.0	3.1	21.6	2.0	3.2
	80	17.9	2.0	2.7	19.0	2.0	2.8	20.0	2.1	2.9
30	60	17.2	1.7	2.9	18.1	1.8	3.0	19.0	1.8	3.0
	70	15.8	1.8	2.6	16.7	1.8	2.7	17.6	1.9	2.7
	80	14.3	1.8	2.3	15.2	1.9	2.4	16.2	1.9	2.5
17	60	7.9	1.6	1.5	11.2	1.6	2.0	14.4	1.7	2.5
	70	9.0	1.6	1.7	11.0	1.7	1.9	13.0	1.7	2.2
	80	10.0	1.6	1.8	10.9	1.7	1.9	11.7	1.7	2.0
10	60	10.5	1.5	2.1	11.2	1.6	2.1	11.9	1.6	2.1
	70	9.3	1.5	1.8	9.9	1.6	1.9	10.6	1.6	1.9
	80	8.0	1.5	1.6	8.6	1.6	1.6	9.3	1.6	1.7

NOTE: ALL CAPACITIES ARE NET (KBTUH) WITH INDOOR FAN HEAT ALREADY DEDUCTED AT 1250 BTUH/1000 CFM.

Multipliers for determining the performance with other indoor sections.

Air Handler	Coil	MBH	KW	COP
–	FC/MC/PC24	1.00	1.00	1.00
–	FC/MC/PC30	1.00	1.00	1.00
–	FC/MC/PC32	1.00	1.00	1.00
–	FC/MC/PC35	1.00	1.00	1.00
–	HC30	0.99	0.99	1.01
–	HC36	1.00	1.00	1.00
–	HD36	1.35	1.41	0.96
AHP30	–	1.01	1.01	1.00
AV24	–	0.96	0.95	1.01
AV36	–	0.98	0.99	0.99
F4FP030	–	0.99	0.99	1.01
MA08B	FC/MC/PC24B	1.00	1.00	1.00
MV12B	FC/MC/PC24B	0.98	0.98	1.00
MA08B	FC/MC/PC30B	1.00	1.00	1.00
MV12B	FC/MC/PC30B	0.98	0.98	1.00
MA08B	FC/MC/PC35B	1.00	1.00	1.00
MV12B	FC/MC/PC35B	0.98	0.98	1.00
MV16C	FC/MC/PC35C	0.98	0.98	1.00

Variable Speed Furnace	Coil	MBH	KW	COP
PV8*A12	FC/MC/PC24A	0.97	0.96	1.01
PV9*A12	FC/MC/PC24A	0.98	0.98	1.00
P(C,V)9*B12	FC/MC/PC24B	0.98	0.98	1.00
PV8*A12	FC/MC/PC30A	0.97	0.96	1.01
PV9*A12	FC/MC/PC30A	0.98	0.98	1.00
P(C,V)9*B12	FC/MC/PC30B	0.98	0.98	1.00
PV8*A12	FC/MC/PC32A	0.97	0.96	1.01
PV9*A12	FC/MC/PC32A	0.99	0.99	1.00
P(C,V)9*B12	FC/MC/PC35B	0.98	0.98	1.00
P(C,V)9*C16	FC/MC/PC35C	0.99	1.00	0.99
PV8*A12	HC30A	0.97	0.95	1.02
PV9*A12	HC30A	0.98	0.97	1.01
P(C,V)9*B12	HC36B	0.98	0.98	1.00
PV8*A12	HD36A	1.30	1.36	0.96
PV9*A12	HD36A	1.34	1.39	0.96
P(C,V)9*B12	HD36B	1.33	1.39	0.96

HEATING PERFORMANCE DATA										
CONDENSING UNIT MODEL NO		THGD30S41S1								
EVAPORATOR COIL MODEL NO		AHP36								
AIR TEMP. ENTERING OUTDOOR UNIT	AIR TEMP. ENTERING INDOOR COIL	ID CFM								
		800			1000			1200		
		MBTUH	KW	C.O.P.	MBTUH	KW	C.O.P.	MBTUH	KW	C.O.P.
60	60	33.0	2.5	3.9	35.7	2.4	4.3	38.5	2.4	4.7
	70	31.4	2.6	3.6	34.1	2.6	3.9	36.9	2.6	4.2
	80	29.8	2.7	3.2	32.5	2.7	3.5	35.2	2.7	3.8
47	60	28.8	2.3	3.6	30.6	2.3	3.9	32.3	2.3	4.1
	70	26.6	2.4	3.2	28.3	2.4	3.4	29.9	2.4	3.6
	80	24.4	2.5	2.9	26.0	2.5	3.0	27.6	2.5	3.2
40	60	25.8	2.2	3.4	27.1	2.3	3.5	28.4	2.3	3.7
	70	24.2	2.3	3.0	25.4	2.3	3.2	26.6	2.4	3.3
	80	22.6	2.4	2.7	23.7	2.4	2.8	24.7	2.5	2.9
30	60	19.3	2.3	2.5	19.9	2.3	2.5	20.4	2.4	2.5
	70	20.8	2.2	2.7	21.5	2.3	2.8	22.2	2.3	2.9
	80	22.3	2.2	3.0	23.1	2.2	3.1	24.0	2.2	3.2
17	60	13.3	2.1	1.9	14.8	2.1	2.0	16.3	2.2	2.2
	70	15.4	2.1	2.2	16.5	2.1	2.3	17.7	2.1	2.4
	80	17.4	2.0	2.5	18.2	2.1	2.6	19.0	2.1	2.7
10	60	13.0	2.0	1.9	10.0	2.1	1.4	6.9	2.1	1.0
	70	14.5	2.0	2.1	13.4	2.0	1.9	12.2	2.1	1.7
	80	16.0	2.0	2.4	16.7	2.0	2.5	17.5	2.0	2.5

NOTE: ALL CAPACITIES ARE NET (KBTUH) WITH INDOOR FAN HEAT ALREADY DEDUCTED AT 1250 BTUH/1000 CFM.

Multipliers for determining the performance with other indoor sections.

Air Handler	Coil	MBH	KW	COP
–	FC/MC/PC32	0.99	0.98	1.01
–	FC/MC/PC35	0.99	0.98	1.01
–	FC/MC/PC37	1.00	1.00	1.00
–	FC/MC/PC43	1.00	1.00	1.00
–	HC36	0.99	0.98	1.01
–	HC42	1.00	1.00	1.00
–	HD48	1.34	1.40	0.96
AHP36	–	1.00	1.00	1.00
AV36	–	0.98	0.98	1.00
F4FP040	–	0.99	0.98	1.02
MA12B	FC/MC/PC35B	0.99	0.98	1.01
MV12B	FC/MC/PC35B	0.97	0.96	1.01
MV16C	FC/MC/PC35C	0.97	0.96	1.01
MA12B	FC/MC/PC43B	1.00	1.00	1.00
MV12B	FC/MC/PC43B	0.98	0.98	1.00
MV16C	FC/MC/PC43C	0.98	0.98	1.00

Variable Speed Furnace	Coil	MBH	KW	COP
PV8*A12	FC/MC/PC32A	0.98	0.96	1.01
PV9*A12	FC/MC/PC32A	0.98	0.97	1.01
PV8*B16	FC/MC/PC35B	0.98	0.97	1.01
PV8*C16	FC/MC/PC35C	0.97	0.96	1.01
PV8*C20	FC/MC/PC35C	0.99	0.99	1.00
P(C,V)9*B12	FC/MC/PC35B	0.98	0.96	1.01
P(C,V)9*C16	FC/MC/PC35C	0.98	0.96	1.01
P(C,V)9*C20	FC/MC/PC35C	0.98	0.96	1.01
PV8*A12	FC/MC/PC37A	0.99	0.99	1.00
PV9*A12	FC/MC/PC37A	0.99	0.99	1.00
PV8*B16	FC/MC/PC43B	0.99	1.00	0.99
PV8*C16	FC/MC/PC43C	0.98	0.98	1.00
PV8*C20	FC/MC/PC43C	1.00	1.01	0.99
P(C,V)9*B12	FC/MC/PC43B	0.98	0.99	1.00
P(C,V)9*C16	FC/MC/PC43C	0.98	0.99	1.00
P(C,V)9*C20	FC/MC/PC43C	0.98	0.99	1.00
PV8*B16	HC36B	0.98	0.97	1.01
P(C,V)9*B12	HC36B	0.98	0.96	1.01
PV8*C16	HC42C	0.98	0.98	1.00
PV8*C20	HC42C	1.00	1.01	0.99
P(C,V)9*C16	HC42C	0.98	0.99	1.00
P(C,V)9*C20	HC42C	0.98	0.99	1.00
PV8*C16	HD48C	1.32	1.38	0.96
PV8*C20	HD48C	1.35	1.39	0.97
P(C,V)9*C16	HD48C	1.32	1.38	0.96
P(C,V)9*C20	HD48C	1.32	1.38	0.96
P(C,V)9*D20	HD48D	1.33	1.38	0.96

HEATING PERFORMANCE DATA										
CONDENSING UNIT MODEL NO		THGD36S41S1								
EVAPORATOR COIL MODEL NO		AHP36								
AIR TEMP. ENTERING OUTDOOR UNIT	AIR TEMP. ENTERING INDOOR COIL	ID CFM								
		1000			1200			1400		
		MBTUH	KW	C.O.P.	MBTUH	KW	C.O.P.	MBTUH	KW	C.O.P.
60	60	44.9	3.1	4.2	46.3	3.2	4.3	47.8	3.2	4.4
	70	42.7	3.3	3.8	44.3	3.3	3.9	45.8	3.4	4.0
	80	40.6	3.4	3.5	42.2	3.5	3.6	43.9	3.5	3.6
47	60	36.8	2.9	3.7	38.6	3.0	3.8	40.5	3.0	3.9
	70	28.4	2.8	3.0	33.4	3.0	3.3	38.5	3.2	3.5
	80	19.9	2.7	2.2	28.2	3.0	2.7	36.5	3.3	3.2
40	60	34.6	2.8	3.6	35.2	2.9	3.6	35.8	3.0	3.5
	70	24.0	3.0	2.4	32.5	3.0	3.2	41.1	3.1	3.9
	80	13.3	3.1	1.3	29.8	3.1	2.8	46.3	3.2	4.3
30	60	28.1	2.7	3.1	29.7	2.8	3.2	31.3	2.8	3.2
	70	25.2	2.8	2.7	27.3	2.9	2.8	29.4	2.9	2.9
	80	22.4	2.9	2.3	24.9	3.0	2.5	27.5	3.0	2.7
17	60	22.2	2.4	2.7	23.1	2.5	2.7	24.0	2.7	2.6
	70	21.0	2.5	2.5	21.6	2.6	2.4	22.2	2.7	2.4
	80	19.8	2.6	2.3	20.1	2.7	2.2	20.3	2.8	2.2
10	60	19.7	2.4	2.4	20.7	2.5	2.5	21.8	2.6	2.5
	70	15.0	2.4	1.8	17.5	2.5	2.1	20.1	2.6	2.2
	80	10.3	2.4	1.3	14.4	2.5	1.7	18.4	2.7	2.0

NOTE: ALL CAPACITIES ARE NET (KBTUH) WITH INDOOR FAN HEAT ALREADY DEDUCTED AT 1250 BTUH/1000 CFM.

Multipliers for determining the performance with other indoor sections.

Air Handler	Coil	MBH	KW	COP
-	FC/MC/PC37	1.01	1.01	1.00
-	FC/MC/PC43	1.01	1.01	1.00
-	FC/MC/PC48	1.01	1.01	1.00
-	HC42	1.01	1.01	1.00
-	HD48	0.96	0.91	1.06
-	HD48	0.96	0.90	1.07
AV36	-	1.00	1.01	0.99
F4FP045	-	1.03	1.06	0.97
MA12B	FC/MC/PC43B	1.01	1.01	1.00
MV12B	FC/MC/PC43B	1.00	1.00	1.00
MV16C	FC/MC/PC43C	0.99	0.99	1.00
MA14D	FC/MC/PC48D	1.01	1.01	1.00
MV12D	FC/MC/PC48D	0.98	0.98	1.01
MV16C	FC/MC/PC48C	0.99	0.99	1.00
MV20D	FC/MC/PC48D	0.99	0.99	1.00

Variable Speed Furnace	Coil	MBH	KW	COP
PV8*A12	FC/MC/PC37A	1.00	1.01	1.00
PV9*A12	FC/MC/PC37A	0.99	0.98	1.01
PV8*B16	FC/MC/PC43B	0.99	1.00	1.00
PV8*C16	FC/MC/PC43C	0.99	0.99	1.00
PV8*C20	FC/MC/PC43C	0.99	0.99	1.00
P(C,V)9*B12	FC/MC/PC43B	1.00	1.00	1.00
P(C,V)9*C16	FC/MC/PC43C	0.99	0.99	1.00
P(C,V)9*C20	FC/MC/PC43C	1.00	1.00	1.00
PV8*C16	FC/MC/PC48C	0.99	1.00	1.00
PV8*C20	FC/MC/PC48C	0.99	1.00	1.00
P(C,V)9*C16	FC/MC/PC48C	0.99	1.00	1.00
P(C,V)9*C20	FC/MC/PC48C	1.00	1.00	1.00
P(C,V)9*D20	FC/MC/PC48D	0.99	1.00	1.00
PV8*C16	HC42C	0.99	0.99	1.00
PV8*C20	HC42C	0.99	0.99	1.00
P(C,V)9*C16	HC42C	0.99	0.99	1.00
P(C,V)9*C20	HC42C	1.00	1.00	1.00
PV8*C16	HD48C	0.94	0.89	1.06
PV8*C20	HD48C	0.94	0.89	1.06
P(C,V)9*C16	HD48C	0.94	0.89	1.06
P(C,V)9*C20	HD48C	0.95	0.89	1.06
P(C,V)9*D20	HD48D	0.94	0.89	1.06

HEATING PERFORMANCE DATA										
CONDENSING UNIT MODEL NO		THGD42S41S1								
EVAPORATOR COIL MODEL NO		FC/MC/PC/UC48								
AIR TEMP. ENTERING OUTDOOR UNIT	AIR TEMP. ENTERING INDOOR COIL	ID CFM								
		1200			1400			1600		
		MBTUH	KW	C.O.P.	MBTUH	KW	C.O.P.	MBTUH	KW	C.O.P.
60	60	48.7	3.5	4.1	48.7	3.5	4.1	48.7	3.4	4.2
	70	47.8	3.8	3.6	48.6	3.8	3.7	49.5	3.8	3.8
	80	46.8	4.2	3.3	48.6	4.2	3.4	50.3	4.1	3.6
47	60	42.5	3.3	3.8	42.9	3.3	3.8	43.3	3.2	3.9
	70	42.3	3.6	3.4	42.7	3.6	3.5	43.1	3.6	3.6
	80	42.0	3.9	3.1	42.4	3.9	3.2	42.9	3.9	3.3
40	60	40.1	3.2	3.7	40.5	3.2	3.7	40.8	3.2	3.8
	70	39.1	3.5	3.3	39.6	3.5	3.3	40.0	3.5	3.4
	80	38.2	3.8	2.9	38.7	3.8	3.0	39.2	3.8	3.0
30	60	33.5	3.8	2.6	33.8	3.7	2.7	34.1	3.7	2.7
	70	34.8	3.4	3.0	34.5	3.4	3.0	34.1	3.4	2.9
	80	36.2	3.1	3.4	35.1	3.1	3.3	34.1	3.1	3.2
17	60	27.8	3.6	2.2	28.4	3.6	2.3	29.1	3.6	2.4
	70	28.3	3.3	2.5	28.8	3.3	2.5	29.2	3.3	2.6
	80	28.8	3.0	2.8	29.1	3.0	2.8	29.4	3.0	2.8
10	60	26.3	3.6	2.1	26.9	3.6	2.2	27.6	3.6	2.2
	70	25.6	3.3	2.3	26.8	3.3	2.4	28.0	3.3	2.5
	80	24.8	3.0	2.4	26.6	3.0	2.6	28.4	3.0	2.8

NOTE: ALL CAPACITIES ARE NET (KBTUH) WITH INDOOR FAN HEAT ALREADY DEDUCTED AT 1250 BTUH/1000 CFM.

Multipliers for determining the performance with other indoor sections.

Air Handler	Coil	MBH	KW	COP
-	FC/MC/PC60	1.00	1.06	0.94
-	HC42	0.99	0.99	1.00
-	HC60	1.00	1.06	0.94
-	HD60	0.99	0.89	1.11
AHP/SHP48	-	1.00	1.00	1.00
AV48	-	0.99	1.05	0.94
F4FP045	-	1.01	1.07	0.94
F5FP048	-	0.99	1.01	0.98
MA14D	FC/MC/PC48D	1.00	1.00	1.00
MA16C	FC/MC/PC48C	1.00	1.00	1.00
MV16C	FC/MC/PC48C	0.99	0.99	1.00
MV20D	FC/MC/PC48D	0.98	0.98	1.00
MA14D	FC/MC/PC60D	1.00	1.06	0.94
MA16C	FC/MC/PC60C	1.00	1.06	0.94
MV20D	FC/MC/PC60D	0.98	1.04	0.94

Variable Speed Furnace	Coil	MBH	KW	COP
PV8*C16	FC/MC/PC48C	0.99	0.99	1.00
PV8*C20	FC/MC/PC48C	0.99	0.99	1.00
P(C,V)9*C16	FC/MC/PC48C	0.99	0.99	1.00
P(C,V)9*C20	FC/MC/PC48C	0.99	0.99	1.00
P(C,V)9*D20	FC/MC/PC48D	0.99	0.99	1.00
PV8*C16	FC/MC/PC60C	0.99	1.05	0.94
PV8*C20	FC/MC/PC60C	0.99	1.05	0.94
P(C,V)9*C16	FC/MC/PC60C	0.99	1.05	0.94
P(C,V)9*C20	FC/MC/PC60C	0.99	1.05	0.94
P(C,V)9*D20	FC/MC/PC60D	0.99	1.05	0.94
PV8*C16	HC42C	0.99	0.98	1.00
PV8*C20	HC42C	0.98	0.98	1.00
P(C,V)9*C16	HC42C	0.99	0.99	1.00
P(C,V)9*C20	HC42C	0.98	0.98	1.00
P(C,V)9*D20	HC60D	0.99	1.05	0.94
PV8*C16	HD60C	0.98	0.88	1.11
PV8*C20	HD60C	0.98	0.88	1.11
P(C,V)9*C16	HD60C	0.98	0.88	1.11
P(C,V)9*C20	HD60C	0.98	0.88	1.11
P(C,V)9*D20	HD60D	0.98	0.88	1.11

HEATING PERFORMANCE DATA										
CONDENSING UNIT MODEL NO		THGD48S41S1								
EVAPORATOR COIL MODEL NO		AHP/SHP48								
AIR TEMP. ENTERING OUTDOOR UNIT	AIR TEMP. ENTERING INDOOR COIL	ID CFM								
		1400			1600			1800		
		MBTUH	KW	C.O.P.	MBTUH	KW	C.O.P.	MBTUH	KW	C.O.P.
60	60	60.1	4.0	4.4	61.4	4.0	4.5	62.7	3.9	4.7
	70	59.0	4.1	4.3	59.2	4.3	4.0	61.1	4.3	4.2
	80	57.9	4.1	4.1	57.0	4.7	3.6	59.5	4.7	3.7
47	60	52.1	3.3	4.7	51.4	3.7	4.0	48.1	3.7	3.8
	70	51.3	3.6	4.2	50.7	4.2	3.6	49.4	4.1	3.5
	80	50.4	3.9	3.8	50.0	4.6	3.2	50.8	4.6	3.2
40	60	47.4	3.2	4.4	45.5	3.7	3.6	48.5	3.7	3.8
	70	46.9	3.5	3.9	45.5	4.1	3.2	47.1	4.1	3.4
	80	46.5	3.9	3.5	45.5	4.5	3.0	45.7	4.5	3.0
30	60	41.8	3.0	4.0	38.4	4.3	2.6	37.3	4.2	2.6
	70	41.5	3.4	3.6	37.5	3.9	2.9	37.9	3.9	2.9
	80	41.3	3.7	3.3	36.6	3.4	3.1	38.4	3.5	3.2
17	60	35.1	2.9	3.6	28.6	3.9	2.2	29.5	4.0	2.2
	70	35.0	3.2	3.2	29.1	3.6	2.4	29.9	3.6	2.4
	80	34.9	3.5	2.9	29.5	3.3	2.6	30.2	3.3	2.7
10	60	32.0	2.8	3.4	25.8	3.9	2.0	26.4	3.9	2.0
	70	31.8	3.1	3.0	26.4	3.6	2.2	27.3	3.6	2.2
	80	31.7	3.4	2.8	27.0	3.3	2.4	28.1	3.4	2.5

NOTE: ALL CAPACITIES ARE NET (KBTUH) WITH INDOOR FAN HEAT ALREADY DEDUCTED AT 1250 BTUH/1000 CFM.

Multipliers for determining the performance with other indoor sections.

Air Handler	Coil	MBH	KW	COP
-	FC/MC/PC48	1.00	0.95	1.04
-	FC/MC/PC60	1.00	1.02	0.99
-	HC60	1.00	1.02	0.99
-	HD60	0.98	0.85	1.16
-	MC62	1.00	0.97	1.03
AHP60	-	0.99	1.01	0.99
AV48	-	0.99	1.01	0.99
AV60	-	1.00	1.01	0.98
F4FV060	-	0.99	1.01	0.99
F5FP048	-	0.99	0.98	1.02
F5FP060	-	1.00	1.02	0.98
MA16C	FC/MC/PC48C	1.00	0.95	1.04
MA20D	FC/MC/PC48D	1.00	0.95	1.04
MV16C	FC/MC/PC48C	0.99	0.94	1.04
MV20D	FC/MC/PC48D	0.99	0.94	1.04
MA16C	FC/MC/PC60C	1.00	1.02	0.99
MA20D	FC/MC/PC60D	1.00	1.02	0.99
MV20D	FC/MC/PC60D	0.99	1.01	0.99
MA20D	MC62D	1.00	0.97	1.03
MV20D	MC62D	0.99	0.96	1.03

Variable Speed Furnace	Coil	MBH	KW	COP
PV8*C16	FC/MC/PC48C	0.99	0.93	1.06
PV8*C20	FC/MC/PC48C	0.99	0.95	1.04
P(C,V)9*C16	FC/MC/PC48C	0.99	0.95	1.04
P(C,V)9*C20	FC/MC/PC48C	0.99	0.95	1.04
P(C,V)9*D20	FC/MC/PC48D	0.99	0.95	1.04
PV8*C16	FC/MC/PC60C	1.00	1.00	1.00
PV8*C20	FC/MC/PC60C	1.00	1.01	0.99
P(C,V)9*C16	FC/MC/PC60C	1.00	1.02	0.99
P(C,V)9*C20	FC/MC/PC60C	1.00	1.01	0.99
P(C,V)9*D20	FC/MC/PC60D	1.00	1.01	0.99
P(C,V)9*D20	HC60D	1.00	1.01	0.99
PV8*C16	HD60C	0.98	0.82	1.19
PV8*C20	HD60C	0.98	0.84	1.16
P(C,V)9*C16	HD60C	0.98	0.85	1.16
P(C,V)9*C20	HD60C	0.98	0.84	1.16
P(C,V)9*D20	HD60D	0.98	0.84	1.16
PV8*C20	MC62C	0.99	0.97	1.03
P(C,V)9*C16	MC62C	1.00	0.97	1.03
P(C,V)9*C20	MC62C	0.99	0.97	1.03
P(C,V)9*D20	MC62D	0.99	0.97	1.03

HEATING PERFORMANCE DATA										
CONDENSING UNIT MODEL NO		THGD60S41S1								
EVAPORATOR COIL MODEL NO		FC/MC62								
AIR TEMP. ENTERING OUTDOOR UNIT	AIR TEMP. ENTERING INDOOR COIL	ID CFM								
		1600			1800			2000		
		MBTUH	KW	C.O.P.	MBTUH	KW	C.O.P.	MBTUH	KW	C.O.P.
60	60	65.7	4.7	4.1	66.7	4.6	4.2	67.6	4.6	4.3
	70	64.7	5.1	3.7	65.4	5.0	3.8	66.1	4.9	3.9
	80	63.8	5.5	3.4	64.1	5.4	3.5	64.5	5.3	3.6
47	60	56.9	4.4	3.8	57.4	4.4	3.9	58.0	4.3	4.0
	70	55.8	4.8	3.4	56.3	4.8	3.5	56.8	4.7	3.5
	80	54.7	5.2	3.1	55.2	5.2	3.1	55.6	5.1	3.2
40	60	51.9	4.3	3.5	51.7	4.3	3.5	51.4	4.3	3.5
	70	50.6	4.8	3.1	51.1	4.7	3.2	51.7	4.7	3.2
	80	49.3	5.2	2.8	50.6	5.1	2.9	51.9	5.0	3.0
30	60	44.1	5.0	2.6	43.6	5.0	2.5	43.1	5.0	2.5
	70	45.3	4.6	2.9	44.8	4.6	2.9	44.4	4.6	2.8
	80	46.5	4.2	3.2	46.1	4.2	3.2	45.6	4.1	3.2
17	60	36.6	5.0	2.2	36.8	4.9	2.2	36.9	4.9	2.2
	70	36.0	4.5	2.4	36.5	4.5	2.4	37.1	4.4	2.4
	80	35.3	4.0	2.6	36.3	4.0	2.6	37.3	4.0	2.7
10	60	27.3	4.7	1.7	27.7	4.6	1.7	28.1	4.6	1.8
	70	30.4	4.4	2.0	31.2	4.3	2.1	32.0	4.3	2.2
	80	33.4	4.0	2.4	34.7	4.0	2.5	35.9	4.0	2.7

NOTE: ALL CAPACITIES ARE NET (KBTUH) WITH INDOOR FAN HEAT ALREADY DEDUCTED AT 1250 BTUH/1000 CFM.

Multipliers for determining the performance with other indoor sections.

Air Handler	Coil	MBH	KW	COP
MA20D	MC62D	1.00	1.00	1.00
MV20D	MC62D	0.99	0.99	1.00

Variable Speed Furnace	Coil	MBH	KW	COP
PV8*C20	MC62C	1.00	1.00	1.00
P(C,V)9*C20	MC62C	0.99	0.97	1.03
P(C,V)9*D20	MC62D	0.99	0.96	1.03