



Heating and Air Conditioning

TECHNICAL GUIDE

SINGLE PACKAGE GAS/ELECTRIC UNITS AND SINGLE PACKAGE AIR CONDITIONERS

DM 036, 048, 060 & 072

3, 4, 5 & 6 NOMINAL TONS

10.0 SEER (3, 4 & 5 TONS), 9.0 EER (6 TONS)

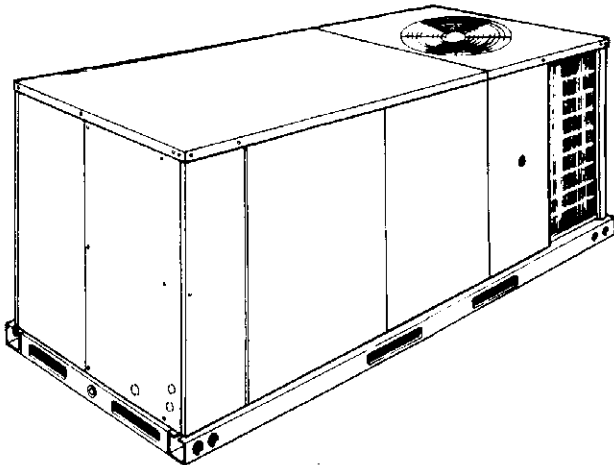

DESCRIPTION

YORK Sunline 2000™ units are convertible single package air conditioners with a common cabinet and a common roof curb for the 3, 4, 5 and 6 ton sizes. The units were designed for light commercial and commercial applications. They can easily be installed on a roof curb, slab, roof jack or frame.

All units include:

- Powder Paint finish that meets ASTM-B-117 750 hour salt spray standards
- Permanently lubricated motors
- Bottom or side air discharge configuration capability (field convertible)
- Manufactured under the quality standards of ISO9001
- Simplicity™ Control Board
- Copper tube/aluminum fin coils
- Easy access to all components
- Rigging holes in base rails for lifting
- Fork lift slots on three sides
- Single point power connection
- Complete factory package - tested, charged and wired
- CSA agency listing on all units

WARRANTY

- Factory Limited Parts Warranty
- One-year parts warranty
- A Five-year parts warranty on the compressor and electric heat elements.
- Ten-year parts warranty on the gas-fired heat exchangers.



TABLE OF CONTENTS

DESCRIPTION	1	9 SUPPLY AIR BLOWER PERFORMANCE (4 TON BELT DRIVE) - SIDE DUCT APPLICATION	17
PRODUCT NOMENCLATURE	3	10 SUPPLY AIR BLOWER PERFORMANCE (5 TON BELT DRIVE) - SIDE DUCT APPLICATION	18
FEATURES	8	11 SUPPLY AIR BLOWER PERFORMANCE (6 TON BELT DRIVE) - SIDE DUCT APPLICATION	19
FACTORY-INSTALLED OPTIONS	9	12 SUPPLY AIR BLOWER PERFORMANCE (3 - 6 TON DIRECT DRIVE)	20
FIELD-INSTALLED ACCESSORIES	10	13 BELT DRIVE MOTOR AND DRIVE DATA	20
GUIDE SPECIFICATIONS	38	14 STATIC RESISTANCES	21

LIST OF FIGURES

Fig. #		Pg. #	
1	UNIT CUTAWAY	9	15 ELECTRIC HEATER CFM LIMITATIONS
2	TYPICAL FIELD POWER & CONTROL WIRING	31	16 ELECT DATA - DM036 & 048 DIRECT DRIVE WITHOUT POWR'D CONVENIENCE OUTLET
3	UNIT DIMENSIONS (3 - 6 TON COOLING ONLY/ ELECTRIC HEAT) FRONT VIEW	32	17 ELECT DATA - DM060 & 072 DIRECT DRIVE WITHOUT POWR'D CONVENIENCE OUTLET
4	UNIT DIMENSIONS (3 - 6 TON COOLING/GAS HEAT) FRONT VIEW	32	18 ELECTRICAL DATA - DM036 & 048 BELT DRIVE WITHOUT POWR'D CONVENIENCE OUTLET
5	UNIT WITH ECONOMIZER RAINHOOD	33	19 ELECTRICAL DATA - DM060 & 072 BELT DRIVE WITHOUT POWR'D CONVENIENCE OUTLET
6	UNIT WITH FIXED OUTDOOR AIR/MOTORIZED DAMPER RAINHOOD	33	20 ELECTRICAL DATA - DM036 & 048 DIRECT DRIVE WITH POWR'D CONVENIENCE OUTLET
7	UNIT DIMENSIONS (REAR VIEW)	34	21 ELECTRICAL DATA - DM060 & 072 DIRECT DRIVE WITH POWR'D CONVENIENCE OUTLET
8	DISCONNECT/BLOWER ACCESS LOCATION	34	22 ELECTRICAL DATA - DM036 & 048 BELT DRIVE WITH POWR'D CONVENIENCE OUTLET
9	TYPICAL APPLICATIONS	35	23 ELECTRICAL DATA - DM060 & 072 BELT DRIVE WITH POWR'D CONVENIENCE OUTLET
10	FOUR AND SIX POINT LOADING	36	24 PHYSICAL DATA
11	ROOF CURB DIMENSIONS	37	25 ELECTRIC HEAT CORRECTION FACTORS

LIST OF TABLES

Tbl. #		Pg. #	
1	SOUND POWER RATING	11	26 VOLTAGE LIMITATIONS
2	CAPACITY RATINGS - (ARI 210/240)	11	27 UTILITIES ENTRY
3	GAS HEAT RATINGS	11	28 MINIMUM CLEARANCES
4	DM036 COOLING CAPACITIES (3 TON)	12	29 DM 4 POINT LOADS WEIGHT DISTRIBUTION
5	DM048 COOLING CAPACITIES (4 TON)	13	30 DM 6 POINT LOADS WEIGHT DISTRIBUTION
6	DM060 COOLING CAPACITIES (5 TON)	14	31 CENTER OF GRAVITY
7	DM072 COOLING CAPACITIES (6 TON)	15	32 OPERATING WEIGHTS (LBS.)
8	SUPPLY AIR BLOWER PERFORMANCE (3 TON BELT DRIVE) - SIDE DUCT APPLICATION	16	

PRODUCT NOMENCLATURE

3-6 Ton Sunline Model Number Nomenclature

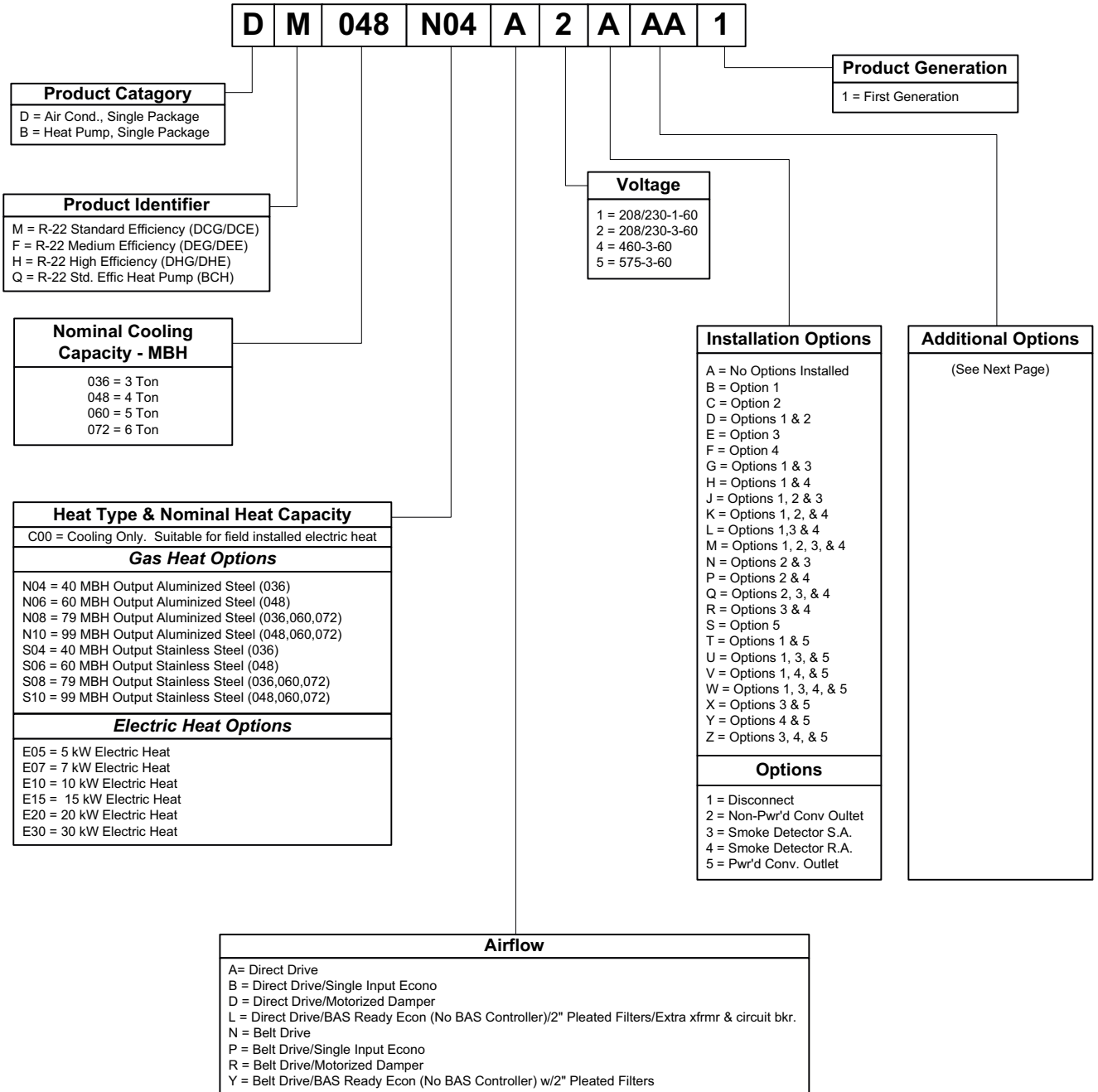

PRODUCT NOMENCLATURE - Continued

3-6T Sunline Model Number Nomenclature

Additional Options	
AA	None
AB	Phase Monitor
AC	Coil Guard
AD	Dirty Filter Switch
AE	Phase Monitor & Coil Guard
AF	Phase Monitor & Dirty Filter Switch
AG	Coil Guard & Dirty Filter Switch
AH	Phase Monitor, Coil Guard, & Dirty Filter Switch
AS	Bottom Condensate Pan
BA	Hinged Filter Door & Toolless Access Panels
BB	Phase Monitor, Hinged Filter Door & Toolless Access Panels
BC	Coil Guard, Hinged Filter Door & Toolless Access Panels
BD	Dirty Filter Switch, Hinged Filter Door & Toolless Access Panels
BE	Phase Monitor & Coil Guard, Hinged Filter Door & Toolless Access Panels
BF	Phase Monitor & Dirty Filter Switch, Hinged Filter Door & Toolless Access Panels
BG	Coil Guard & Dirty Filter Switch, Hinged Filter Door & Toolless Access Panels
BH	Phase Monitor, Coil Guard, & Dirty Filter Switch, Hinged Filter Door & Toolless Access Panels
CA	CPC Controller with Dirty Filter Switch & Air Proving Switch
CB	CPC Controller, DFS, APS & Phase Monitor
CC	CPC Controller, DFS, APS & Coil Guard
CD	CPC Controller, DFS, APS, Phase Monitor, & Coil Guard
CE	CPC Controller, DFS, APS & Technicoat Cond. Coil
CF	CPC Controller, DFS, APS, Technicoat Cond. Coil, & Phase Monitor
CG	CPC Controller, DFS, APS, Technicoat Cond. Coil, & Coil Guard
CH	CPC Controller, DFS, APS, Technicoat Cond. Coil, Phase Monitor, & Coil Guard
CJ	CPC Controller, DFS, APS & Technicoat Evap. Coil
CK	CPC Controller, DFS, APS, Technicoat Evap. Coil, & Phase Monitor
CL	CPC Controller, DFS, APS, Technicoat Evap. Coil, & Coil Guard
CM	CPC Controller, DFS, APS, Technicoat Evap. Coil, Phase Monitor, & Coil Guard
CN	CPC Controller, DFS, APS & Technicoat Evap. & Cond Coils
CP	CPC Controller, DFS, APS, Technicoat Evap. & Cond Coils, & Phase Monitor
CQ	CPC Controller, DFS, APS, Technicoat Evap. & Cond Coils, & Coil Guard
CR	CPC Controller, DFS, APS, Technicoat Evap. & Cond Coils, Phase Monitor, & Coil Guard
DA	CPC Controller with Dirty Filter Switch & Air Proving Switch, Hinged Filter Door & Toolless Access Panels
DB	CPC Controller, DFS, APS & Phase Monitor, Hinged Filter Door & Toolless Access Panels
DC	CPC Controller, DFS, APS & Coil Guard, Hinged Filter Door & Toolless Access Panels
DD	CPC Controller, DFS, APS, Phase Monitor, & Coil Guard, Hinged Filter Door & Toolless Access Panels
DE	CPC Controller, DFS, APS & Technicoat Cond. Coil, Hinged Filter Door & Toolless Access Panels
DF	CPC Controller, DFS, APS, Technicoat Cond. Coil, & Phase Monitor, Hinged Filter Door & Toolless Access Panels
DG	CPC Controller, DFS, APS, Technicoat Cond. Coil, & Coil Guard, Hinged Filter Door & Toolless Access Panels
DH	CPC Controller, DFS, APS, Technicoat Cond. Coil, Phase Monitor, & Coil Guard, Hinged Filter Door & Toolless Access Panels
DJ	CPC Controller, DFS, APS & Technicoat Evap. Coil, Hinged Filter Door & Toolless Access Panels
DK	CPC Controller, DFS, APS, Technicoat Evap. Coil, & Phase Monitor, Hinged Filter Door & Toolless Access Panels
DL	CPC Controller, DFS, APS, Technicoat Evap. Coil, & Coil Guard, Hinged Filter Door & Toolless Access Panels
DM	CPC Controller, DFS, APS, Technicoat Evap. Coil, Phase Monitor, & Coil Guard, Hinged Filter Door & Toolless Access Panels
DN	CPC Controller, DFS, APS & Technicoat Evap. & Cond Coils, Hinged Filter Door & Toolless Access Panels
DP	CPC Controller, DFS, APS, Technicoat Evap. & Cond Coils, & Phase Monitor, Hinged Filter Door & Toolless Access Panels
DQ	CPC Controller, DFS, APS, Technicoat Evap. & Cond Coils, & Coil Guard, Hinged Filter Door & Toolless Access Panels
DR	CPC Controller, DFS, APS, Technicoat Evap. & Cond Coils, Phase Monitor, & Coil Guard, Hinged Filter Door & Toolless Access Panels

Additional Options	
JA	Johnson UNT Controller with Dirty Filter Switch & Air Proving Switch
JB	Johnson UNT Controller, DFS, APS & Phase Monitor
JC	Johnson UNT Controller, DFS, APS & Coil Guard
JD	Johnson UNT Controller, DFS, APS, Phase Monitor, & Coil Guard
JE	Johnson UNT Controller, DFS, APS & Technicoat Cond. Coil
JF	Johnson UNT Controller, DFS, APS, Technicoat Cond. Coil, & Phase Monitor
JG	Johnson UNT Controller, DFS, APS, Technicoat Cond. Coil, & Coil Guard
JH	Johnson UNT Controller, DFS, APS, Technicoat Cond. Coil, Phase Monitor, & Coil Guard
JJ	Johnson UNT Controller, DFS, APS & Technicoat Evap. Coil
JK	Johnson UNT Controller, DFS, APS, Technicoat Evap. Coil, & Phase Monitor
JL	Johnson UNT Controller, DFS, APS, Technicoat Evap. Coil, & Coil Guard
JM	Johnson UNT Controller, DFS, APS, Technicoat Evap. Coil, Phase Monitor, & Coil Guard
JN	Johnson UNT Controller, DFS, APS & Technicoat Evap. & Cond Coils
JP	Johnson UNT Controller, DFS, APS, Technicoat Evap. & Cond Coils, & Phase Monitor
JQ	Johnson UNT Controller, DFS, APS, Technicoat Evap. & Cond Coils, & Coil Guard
JR	Johnson UNT Controller, DFS, APS, Technicoat Evap. & Cond Coils, Phase Monitor, & Coil Guard
NA	Novar ETC-3 Controller with Dirty Filter Switch & Air Proving Switch
NB	Novar ETC-3 Controller, DFS, APS & Phase Monitor
NC	Novar ETC-3 Controller, DFS, APS & Coil Guard
ND	Novar ETC-3 Controller, DFS, APS, Phase Monitor, & Coil Guard
NE	Novar ETC-3 Controller, DFS, APS & Technicoat Cond. Coil
NF	Novar ETC-3 Controller, DFS, APS, Technicoat Cond. Coil, & Phase Monitor
NG	Novar ETC-3 Controller, DFS, APS, Technicoat Cond. Coil, & Coil Guard
NH	Novar ETC-3 Controller, DFS, APS, Technicoat Cond. Coil, Phase Monitor, & Coil Guard
NJ	Novar ETC-3 Controller, DFS, APS & Technicoat Evap. Coil
NK	Novar ETC-3 Controller, DFS, APS, Technicoat Evap. Coil, & Phase Monitor
NL	Novar ETC-3 Controller, DFS, APS, Technicoat Evap. Coil, & Coil Guard
NM	Novar ETC-3 Controller, DFS, APS, Technicoat Evap. Coil, Phase Monitor, & Coil Guard
NN	Novar ETC-3 Controller, DFS, APS & Technicoat Evap. & Cond Coils
NP	Novar ETC-3 Controller, DFS, APS, Technicoat Evap. & Cond Coils, & Phase Monitor
NQ	Novar ETC-3 Controller, DFS, APS, Technicoat Evap. & Cond Coils, & Coil Guard
NR	Novar ETC-3 Controller, DFS, APS, Technicoat Evap. & Cond Coils, Phase Monitor, & Coil Guard
PA	Novar ETC-3 Controller with Dirty Filter Switch & Air Proving Switch, Hinged Filter Door & Toolless Access Panels
PB	Novar ETC-3 Controller, DFS, APS & Phase Monitor, Hinged Filter Door & Toolless Access Panels
PC	Novar ETC-3 Controller, DFS, APS & Coil Guard, Hinged Filter Door & Toolless Access Panels
PD	Novar ETC-3 Controller, DFS, APS, Phase Monitor, & Coil Guard, Hinged Filter Door & Toolless Access Panels
PE	Novar ETC-3 Controller, DFS, APS & Technicoat Cond. Coil, Hinged Filter Door & Toolless Access Panels
PF	Novar ETC-3 Controller, DFS, APS, Technicoat Cond. Coil, & Phase Monitor, Hinged Filter Door & Toolless Access Panels
PG	Novar ETC-3 Controller, DFS, APS, Technicoat Cond. Coil, & Coil Guard, Hinged Filter Door & Toolless Access Panels
PH	Novar ETC-3 Controller, DFS, APS, Technicoat Cond. Coil, Phase Monitor, & Coil Guard, Hinged Filter Door & Toolless Access Panels
PJ	Novar ETC-3 Controller, DFS, APS & Technicoat Evap. Coil, Hinged Filter Door & Toolless Access Panels
PK	Novar ETC-3 Controller, DFS, APS, Technicoat Evap. Coil, & Phase Monitor, Hinged Filter Door & Toolless Access Panels
PL	Novar ETC-3 Controller, DFS, APS, Technicoat Evap. Coil, & Coil Guard, Hinged Filter Door & Toolless Access Panels
PM	Novar ETC-3 Controller, DFS, APS, Technicoat Evap. Coil, Phase Monitor, & Coil Guard, Hinged Filter Door & Toolless Access Panels
PN	Novar ETC-3 Controller, DFS, APS & Technicoat Evap. & Cond Coils, Hinged Filter Door & Toolless Access Panels
PP	Novar ETC-3 Controller, DFS, APS, Technicoat Evap. & Cond Coils, & Phase Monitor, Hinged Filter Door & Toolless Access Panels
PQ	Novar ETC-3 Controller, DFS, APS, Technicoat Evap. & Cond Coils, & Coil Guard, Hinged Filter Door & Toolless Access Panels
PR	Novar ETC-3 Controller, DFS, APS, Technicoat Evap. & Cond Coils, Phase Monitor, & Coil Guard, Hinged Filter Door & Toolless Access Panels
TA	Technicoat Condenser Coil
TB	Technicoat Condenser Coil & Phase Monitor
TC	Technicoat Condenser Coil & Coil Guard

Additional Options	
TD	Technicoat Condenser Coil & Dirty Filter Switch
TE	Technicoat Condenser Coil, Phase Monitor, & Coil Guard
TF	Technicoat Condenser Coil, Phase Monitor, & Dirty Filter Switch
TG	Technicoat Condenser Coil, Coil Guard, & Dirty Filter Switch
TH	Technicoat Condenser Coil, Phase Monitor, Coil Guard, & Dirty Filter Switch
TJ	Technicoat Evaporator Coil
TK	Technicoat Evaporator Coil & Phase Monitor
TL	Technicoat Evaporator Coil & Coil Guard
TM	Technicoat Evaporator Coil & Dirty Filter Switch
TN	Technicoat Evaporator Coil, Phase Monitor, & Coil Guard
TP	Technicoat Evaporator Coil, Phase Monitor, & Dirty Filter Switch
TQ	Technicoat Evaporator Coil, Coil Guard, & Dirty Filter Switch
TR	Technicoat Evaporator Coil, Phase Monitor, Coil Guard, & Dirty Filter Switch
TS	Technicoat Evaporator & Condenser Coils
TT	Technicoat Evaporator & Condenser Coils & Phase Monitor
TU	Technicoat Evaporator & Condenser Coils & Coil Guard
TV	Technicoat Evaporator & Condenser Coils & Dirty Filter Switch
TW	Technicoat Evaporator & Condenser Coils, Phase Monitor, & Coil Guard
TX	Technicoat Evaporator & Condenser Coils, Phase Monitor, & Dirty Filter Switch
TY	Technicoat Evaporator & Condenser Coils, Coil Guard, & Dirty Filter Switch
TZ	Technicoat Evaporator & Condenser Coils, Phase Monitor, Coil Guard, & Dirty Filter Switch
UA	Technicoat Condenser Coil, Hinged Filter Door & Toolless Access Panels
UB	Technicoat Condenser Coil & Phase Monitor, Hinged Filter Door & Toolless Access Panels
UC	Technicoat Condenser Coil & Coil Guard, Hinged Filter Door & Toolless Access Panels
UD	Technicoat Condenser Coil & Dirty Filter Switch, Hinged Filter Door & Toolless Access Panels
UE	Technicoat Condenser Coil, Phase Monitor, & Coil Guard, Hinged Filter Door & Toolless Access Panels
UF	Technicoat Condenser Coil, Phase Monitor, & Dirty Filter Switch, Hinged Filter Door & Toolless Access Panels
UG	Technicoat Condenser Coil, Coil Guard, & Dirty Filter Switch, Hinged Filter Door & Toolless Access Panels
UH	Technicoat Condenser Coil, Phase Monitor, Coil Guard, & Dirty Filter Switch, Hinged Filter Door & Toolless Access Panels
UJ	Technicoat Evaporator Coil, Hinged Filter Door & Toolless Access Panels
UK	Technicoat Evaporator Coil & Phase Monitor, Hinged Filter Door & Toolless Access Panels
UL	Technicoat Evaporator Coil & Coil Guard, Hinged Filter Door & Toolless Access Panels
UM	Technicoat Evaporator Coil & Dirty Filter Switch, Hinged Filter Door & Toolless Access Panels
UN	Technicoat Evaporator Coil, Phase Monitor, & Coil Guard, Hinged Filter Door & Toolless Access Panels
UP	Technicoat Evaporator Coil, Phase Monitor, & Dirty Filter Switch, Hinged Filter Door & Toolless Access Panels
UQ	Technicoat Evaporator Coil, Coil Guard, & Dirty Filter Switch, Hinged Filter Door & Toolless Access Panels
UR	Technicoat Evaporator Coil, Phase Monitor, Coil Guard, & Dirty Filter Switch, Hinged Filter Door & Toolless Access Panels
US	Technicoat Evaporator & Condenser Coils, Hinged Filter Door & Toolless Access Panels
UT	Technicoat Evaporator & Condenser Coils & Phase Monitor, Hinged Filter Door & Toolless Access Panels
UU	Technicoat Evaporator & Condenser Coils & Coil Guard, Hinged Filter Door & Toolless Access Panels
UV	Technicoat Evaporator & Condenser Coils & Dirty Filter Switch, Hinged Filter Door & Toolless Access Panels
UW	Technicoat Evaporator & Condenser Coils, Phase Monitor, & Coil Guard, Hinged Filter Door & Toolless Access Panels
UX	Technicoat Evaporator & Condenser Coils, Phase Monitor, & Dirty Filter Switch, Hinged Filter Door & Toolless Access Panels
UY	Technicoat Evaporator & Condenser Coils, Coil Guard, & Dirty Filter Switch, Hinged Filter Door & Toolless Access Panels
UZ	Technicoat Evaporator & Condenser Coils, Phase Monitor, Coil Guard, & Dirty Filter Switch, Hinged Filter Door & Toolless Access Panels

FEATURES

All models are available with a wide variety of factory-mounted options such as stainless steel heat exchangers, phase monitor, dirty filter switch, and coil guard to make them suitable for almost every application.

All units are self-contained and assembled on full perimeter base rails with forklift holes on three sides and holes for overhead rigging. Every unit is completely piped, wired, charged and tested at the factory to simplify the field installation and to provide years of dependable operation.

All models (including those with an economizer) are suitable for either bottom or horizontal duct connections. For bottom duct, remove the sheet metal panels from the supply and return air openings through the base of the unit. For horizontal duct, remove the supply and return air panels on the rear of the unit.

All models are available with these “factory mounted” outdoor air damper options:

- Single enthalpy economizer
- Motorized outdoor air damper

Supply air blowers are equipped with either a direct drive or a belt drive that can be adjusted to meet the exact requirements of the job.

All compressors are equipped with internal pressure relief. Every refrigerant circuit includes a liquid line filter-drier, a high pressure switch and a suction line with a freeze-stat and low pressure/loss of charge switch to protect all system components.

- **Simplicity™ Controls** - Simplicity™ control boards have standardized a number of features previously available only as options or by utilizing additional controls.
 - **Low Ambient** - An integrated low-ambient control allows all units to operate in the cooling mode down to 0°F outdoor ambient without additional assistance. Optionally, the control board can be programmed to lockout the compressors when the outdoor air temperature is low or when free cooling is available.
 - **Anti-Short Cycle Protection** - To aid compressor life, an anti-short cycle delay is incorporated into the standard controls. Compressor reliability is further ensured by programmable minimum run times. For testing, the anti short cycle delay can be temporarily overridden with the push of a button.
 - **Fan Delays** - Fan on and fan off delays are fully programmable and are independent of one another. All units are programmed with default values based upon their configuration of cooling and heat.
 - **Safety Monitoring** - The control board monitors the high and low-pressure switches, the freeze-stats, the

gas valve, if applicable, and the temperature limit switch on gas heat units. The unit control board will alarm on ignition failures, compressor lockouts and repeated limit switch trips.

- **Nuisance Trip Protection**- To prevent nuisance trouble calls, the control board uses a “three strikes, you’re out” philosophy. The high and low-pressure switches and the freeze-stats must trip three times within two hours before the unit control board will lock out the compressor.
- **On Board Diagnostics** - Each alarm will energize a trouble light on the thermostat, if so equipped, and flash an alarm code on the control board LED. Each high and low-pressure switch alarm as well as each freeze-stat alarm has its own flash code. The control board saves the five most recent alarms in memory, and these alarms can be reviewed at any time. Alarms and programmed values are retained through the loss of power.

All units have long lasting powder paint cabinets with 750 hour salt spray test approval under ASTM-B117 procedures.

All models are CSA listed.

- **Warranty** - All models include a one-year limited parts warranty on the complete unit. Compressors and electric heater elements carry a five-year warranty. Gas heat exchangers carry a 10-year parts warranty.
- **Gas Heat Operation** - All gas heat units have a minimum AFUE of 80%. Each section includes a durable heat exchanger with aluminized steel or optional stainless steel tubes, a redundant gas valve, spark ignition, power venting, an ignition module for 100% shut-off and all of the safety controls required to meet the latest ANSI standards.

The gas supply piping can be routed into the heating compartment through a hole in the base pan of the unit or through a knockout in the piping panel on the front of the unit.

- **Electric Heat Operation** - All electric heat models are wired for a single power source and include a bank of nickel chromium elements mounted at the discharge of the supply air blower to provide a high velocity and uniform distribution of air across the heating elements. Every element is fully protected against excessive temperature by thermal limit switches.

The power supply wiring can be routed into the control box through a threaded pipe connection (field supplied) in the base pan of the unit or through a knockout in the wiring panel on the side of the unit.

- **BAS Controls** - York’s Sunline™ series units offer factory mounted BAS controls such as Novar, Honeywell, Johnson, and CPC.

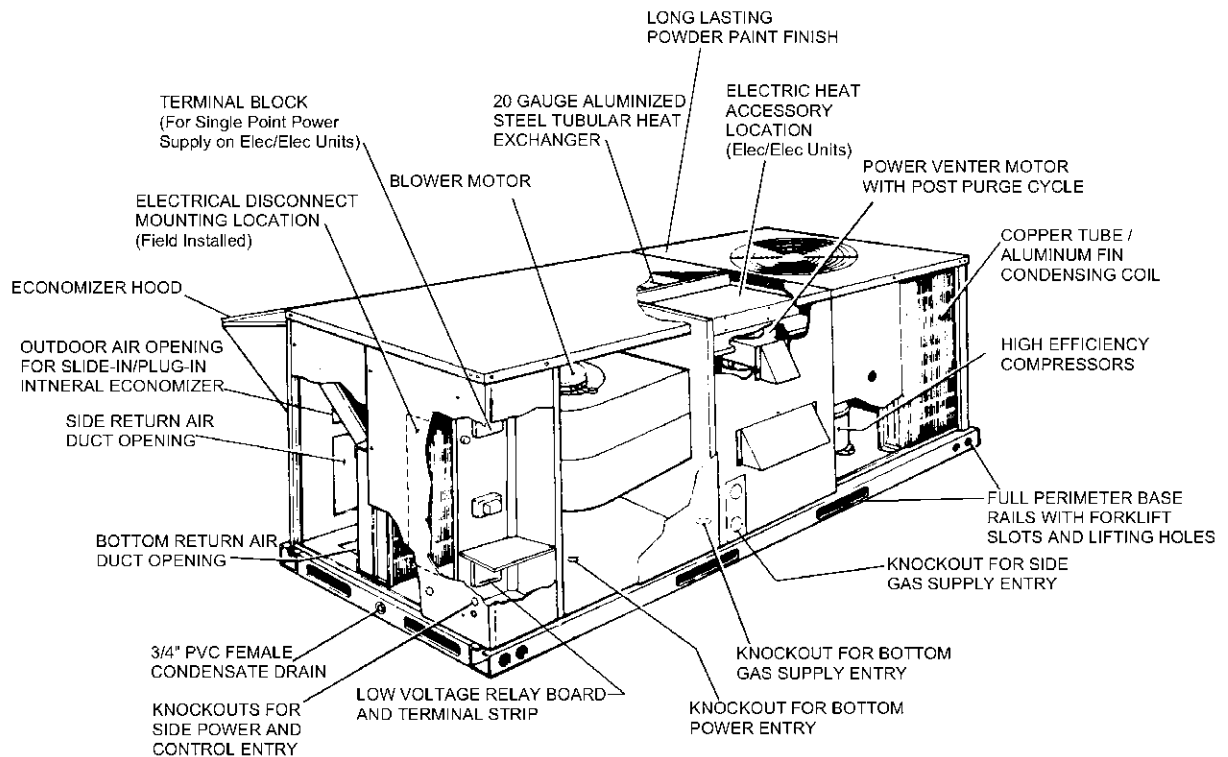

FIGURE 1: UNIT CUTAWAY

FACTORY-INSTALLED OPTIONS

- **SINGLE INPUT ELECTRONIC ENTHALPY ECONOMIZERS** - Includes a slide-in / plug-in damper assembly with fully modulating spring-return motor actuator capable of introducing up to 100% outdoor air with nominal 1% leakage type dampers.

The enthalpy system contains one sensor that monitors the outdoor air and determines when the air is cool enough and dry enough to provide free cooling.

The rainhood is painted to match the basic unit and must be field-assembled before installing.

- **MOTORIZED OUTDOOR AIR INTAKE DAMPER** - Includes a slide-in / plug-in damper assembly with a 2-position, spring return motor actuator which opens to a pre-set position whenever the supply air blower is operating and will drive fully closed when the blower unit shuts down.
The rain hood is painted to match the basic unit and must be field assembled before installing.
- **PHENOLIC COATED EVAPORATOR AND CONDENSER COILS** - Special coating process that utilizes Technicoat 10-1™ processes. Coating is applied by total immersion of the complete coil for maximum protection.

- **ELECTRIC HEATERS** wired for single point power supply. These nickel chromium heater elements are provided with limit and automatic reset capability to prevent operation at excessive temperatures.
- **FILTER OPTIONS** - Standard units are shipped with 1" throw-away filters installed. 2" pleated filters are offered as a factory installed option.
- **CONVENIENCE OUTLET** - This 110 volt outlet can be "powered" by the unit with a stepdown transformer or the unit may be ordered with a "non-powered" convenience outlet that can be wired in the field.
- **DISCONNECT SWITCH** - For gas heat units and cooling units with electric heat, a HACR breaker sized to the unit is provided. For cooling only units, a switch sized to the largest electric heat available for the particular unit is provided. Factory installed option only.
- **BAS** - See "Additional Options" section in the product nomenclature.
- **SMOKE DETECTORS** - (supply air & return air) The smoke detectors stop operation of the unit by interrupting power to the control board if smoke is detected within the air compartment.

- **COIL GUARD** - Customers can purchase a coil guard kit to protect the condenser coil from damage. This is not a hail guard kit.
- **STAINLESS STEEL HEAT EXCHANGER** - For applications in corrosive environments, this option provides a full stainless steel heat exchanger assembly.
- **PHASE MONITORS** - Designed to prevent unit damage. The phase monitor will shut the unit down in an out-of-phase condition.
- **DIRTY FILTER SWITCH** - This kit includes a differential pressure switch that energizes the fault light on the unit thermostat, indicating that there is an abnormally high pressure drop across the filters. Factory installed option or field installed accessory.
- **HINGED FILTER DOOR/"TOOLLESS" BLOWER AND ACCESS PANELS** (not hinged) - This option allows for easy access and maintenance.

NOTE: Knobs are shipped inside the unit to prevent shipping damage. These must be field installed for tool-less operation.

FIELD-INSTALLED ACCESSORIES

- **SINGLE INPUT ELECTRONIC ENTHALPY ECONOMIZERS** - Includes a slide-in / plug-in damper assembly with fully modulating spring-return motor actuator capable of introducing up to 100% outdoor air with nominal 1% leakage type dampers.

The enthalpy system contains one sensor that monitors the outdoor air and determines when the air is cool enough and dry enough to provide free cooling.

The rainhood is painted to match the basic unit and must be field-assembled before installing.

- **MOTORIZED OUTDOOR AIR INTAKE DAMPER** - Includes a slide-in / plug-in damper assembly with a 2-position, spring return motor actuator which opens to some pre-set position whenever the supply air blower is operating and will drive fully closed when the blower unit shuts down.

The rain hood is painted to match the basic unit and must be field assembled before installing.

- **ELECTRIC HEATERS** wired for single point power supply. These nickel chromium heater elements are provided with limit and automatic reset capability to prevent operation at excessive temperatures.
- **ROOF CURBS** - Eight and fourteen-inch high roof curbs provide a water-tight seal between the unit and the finished roof. These full perimeter curbs meet the requirements of the National Roofing Contractors Association (NRCA) and are shipped knocked-down for field assembly.

Roof curbs are designed to fit inside the base rails of the unit and include both a wood nailing strip and duct hanger supports.

- **HIGH ALTITUDE NATURAL GAS** - Burner orifices and pilot orifices are provided for proper furnace operation at altitudes up to 6,000 feet.
- **PROPANE** - Burner orifices, pilot orifices and gas valve parts are provided to convert a natural gas furnace to propane.
- **HIGH ALTITUDE PROPANE** - Burner orifices and pilot orifices are provided for proper furnace operation at altitudes up to 6,000 feet. This accessory supplements the basic propane conversion kit.
- **LOW NOX KIT**- Required to reduce the emission of nitrogen oxides below 40 nanograms per joule.
- **POWER EXHAUST** - Our single input economizer options are available with power exhaust. Whenever the outdoor air intake dampers are opened for free cooling, the exhaust fan will be energized to prevent the conditioned space from being over-pressurized during economizer operation.

The power exhaust option can only be used on bottom duct configurations.

- **BAROMETRIC RELIEF DAMPER** - This damper accessory can be used to relieve internal building air pressure on units with an economizer without power exhaust. This accessory includes a rain hood, a bird screen and a fully assembled damper. With bottom duct connections, the damper should be mounted over the opening in the return air panel. With horizontal ductwork, the accessory should be mounted on the return air duct.
- **ENTHALPY ACCESSORY CONTROL KIT** - This kit contains the required components to convert a single enthalpy economizer to dual enthalpy.
- **BURGLAR BARS** - Mount in the supply and return openings to prevent entry into the duct work.
- **FLUE EXHAUST EXTENSION KIT** - In locations with wind or weather conditions which may interfere with proper exhausting of furnace combustion products, this kit can be installed to prevent the flue exhaust from entering nearby fresh air intakes.
- **CO₂ SENSOR** - Senses CO₂ levels and automatically overrides the economizer when levels rise above the present limits.
- **COIL GUARD** - Customers can purchase a coil guard kit to protect the condenser coil from damage. This is not a hail guard kit.

TABLE 1: SOUND POWER RATING¹

UNIT SIZE	CFM	ESP	BLOWER		SOUND POWER (db 10 ⁻¹² Watts)								SWL dB(A)	dB(A) @ 10Ft. ²
					Octave Band Centerline Frequency (Hz)									
					IWG	SPEED	KW	63	125	250	500	1,000		
036	1,200	0.6	LOW	0.60	84	84	74	67	69	62	57	52	74	41
048	1,600	0.55	HIGH	0.80	85	85	75	68	70	63	58	53	75	42
060	2,000	0.45	HIGH	1.00	86	86	76	69	71	64	59	54	76	43
072	2,200	0.3	HIGH	1.35	87	87	77	70	72	65	60	55	77	44

1. These values have been accessed using a model of sound propagation from a point source into the hemispheric/free field. The dBA values provided are to be used for reference only. Calculation of dBA values cover matters of system design and the fan manufacture has no way of knowing the details of each system. This constitutes an expectation to any specification or guarantee requiring a dBA value or sound data in any other form than sound power level ratings.
2. At a distance of 10 feet from the blower.

TABLE 2: CAPACITY RATINGS - (ARI 210/240)¹

MODEL	MBH	EER ²	SEER ³
DM036	36.0	9.1	10.0
DM048	47.4	9.0	10.0
DM060	59.0	9.1	10.0
DM072	72.0	9.0	-

1. 80/67°F Indoor and 95°F outdoor.
2. EER = Energy Efficiency Ratio at full load - the cooling capacity in Btu's per hour (Btuh) divided by the power input in watts, expressed in Btuh per watt (Btuh/watt).
3. SEER = Seasonal Energy Efficiency Ratio.

TABLE 3: GAS HEAT RATINGS¹

MODEL	MBH INPUT	MBH OUTPUT	AFUE (%)	TEMP RISE °F
DM036N04	50	40	80.9	15 - 45
DM036N08	100	79	80.5	40 - 70
DM048N06	75	59	80.9	25 - 55
DM048N10	125	99	80.3	45 - 75
DM060N08	100	79	80.5	25 - 55
DM060N10	125	99	80.3	35 - 65
DM072N08	100	79	80.5	25 - 55
DM072N10	125	99	80.3	35 - 65

1. All units are single-stage heating.

TABLE 4: DM036 COOLING CAPACITIES (3 TON)

AIR ON EVAPORATOR COIL		TEMPERATURE OF AIR ON CONDENSER COIL																			
		85°F								95°F											
		TOTAL CAP. ¹ MBH	POWER INPUT ² kW	SENSIBLE CAPACITY ¹								TOTAL CAP. ¹ MBH	POWER INPUT ² kW	SENSIBLE CAPACITY ¹							
				ENTERING DRY BULB, °F										ENTERING DRY BULB, °F							
CFM	WB °F			86	83	80	77	74	71	68			86	83	80	77	74	71	68		
1750	72	45	3.1	35	30	26	21	17	-	-	43	3.3	35	30	26	21	17	-	-		
	67	43	3.0	43	38	34	29	25	20	16	41	3.3	41	38	34	29	25	21	16		
	62	39	3.0	39	39	39	34	30	25	21	36	3.3	36	36	36	32	27	23	18		
1475	57	40	2.9	40	40	40	35	31	26	22	38	3.2	38	38	38	33	29	24	20		
	72	44	3.1	31	28	24	20	16	-	-	42	3.3	31	27	23	20	16	-	-		
	67	41	3.0	39	35	31	27	23	19	16	39	3.3	37	35	31	27	23	19	15		
	62	38	3.0	38	38	37	33	29	25	21	36	3.3	36	36	35	31	27	23	19		
1200	57	39	2.9	39	39	39	35	31	27	23	37	3.2	37	37	36	32	28	25	21		
	72	42	3.1	28	25	22	18	15	-	-	41	3.3	28	24	21	18	14	-	-		
	67	40	3.0	35	32	28	25	22	18	15	38	3.2	34	31	28	25	21	18	15		
	62	36	3.0	36	36	35	31	28	25	21	35	3.3	35	35	34	30	27	24	20		
1050	57	37	2.9	37	37	37	34	31	27	24	36	3.2	36	36	35	32	28	25	22		
	72	41	3.1	26	23	20	17	14	-	-	39	3.2	26	23	20	17	14	-	-		
	67	38	3.0	32	30	27	24	21	18	15	37	3.2	32	29	26	23	20	17	14		
	62	35	3.0	35	35	33	30	27	24	21	33	3.2	33	33	31	28	25	22	20		
900	57	36	2.9	36	36	35	32	29	26	23	34	3.2	34	34	32	30	27	24	21		
	72	39	3.1	24	21	19	16	14	-	-	38	3.2	23	21	18	16	13	-	-		
	67	37	3.0	30	27	25	22	20	17	15	36	3.2	29	26	24	21	19	16	14		
	62	34	3.0	34	33	30	28	25	23	20	32	3.2	32	31	29	26	24	21	19		
	57	34	2.9	34	34	33	30	27	25	22	33	3.1	33	33	30	27	25	22	20		

AIR ON EVAPORATOR COIL		TEMPERATURE OF AIR ON CONDENSER COIL																			
		105°F								115°F											
		TOTAL CAP. ¹ MBH	POWER INPUT ² kW	SENSIBLE CAPACITY ¹								TOTAL CAP. ¹ MBH	POWER INPUT ² kW	SENSIBLE CAPACITY ¹							
				ENTERING DRY BULB, °F										ENTERING DRY BULB, °F							
CFM	WB °F			86	83	80	77	74	71	68			86	83	80	77	74	71	68		
1750	72	41	3.7	34	29	25	20	16	-	-	39	4.1	33	28	24	19	15	-	-		
	67	38	3.7	38	37	33	28	24	19	15	36	4.0	36	36	32	27	23	18	14		
	62	34	3.7	34	34	34	30	25	21	16	32	4.0	32	32	32	27	23	18	14		
	57	35	3.6	35	35	35	31	26	22	17	33	4.0	33	33	33	28	24	19	15		
1475	72	40	3.7	30	26	23	19	15	-	-	38	4.1	30	26	22	18	14	-	-		
	67	37	3.6	36	34	30	26	22	18	14	35	4.0	34	33	29	25	21	17	13		
	62	33	3.7	33	33	33	29	25	21	17	31	4.0	31	31	31	27	23	19	15		
	57	34	3.6	34	34	34	30	26	22	18	32	4.0	32	32	32	28	24	20	16		
1200	72	39	3.7	27	24	20	17	14	-	-	37	4.1	26	23	20	16	13	-	-		
	67	36	3.6	34	30	27	24	20	17	14	34	4.0	33	30	26	23	20	16	13		
	62	32	3.6	32	32	32	29	25	22	19	30	4.0	30	30	30	27	24	20	17		
	57	33	3.6	33	33	33	29	26	23	19	31	3.9	31	31	31	27	24	21	17		
1050	72	37	3.6	25	22	19	16	13	-	-	36	4.1	24	21	18	15	12	-	-		
	67	35	3.6	31	28	25	22	19	16	13	32	4.0	30	27	24	21	18	15	12		
	62	31	3.6	31	31	29	27	24	21	18	29	4.0	29	29	28	25	22	19	16		
	57	32	3.5	32	32	30	27	24	21	18	30	3.9	30	29	28	25	22	19	16		
900	72	36	3.6	22	20	17	15	12	-	-	34	4.0	21	19	16	14	11	-	-		
	67	33	3.6	28	25	23	20	18	15	13	31	4.0	27	24	22	19	17	14	11		
	62	30	3.6	30	29	27	24	22	19	17	28	4.0	28	28	25	22	20	17	15		
	57	31	3.5	31	30	28	25	22	20	17	28	3.9	28	28	25	23	20	17	15		

1. These capacities are gross ratings. For net capacity, determine the kW of the supply air blower motor from the SUPPLY AIR BLOWER PERFORMANCE Table, multiply this value by 3.415 MBH/kW to determine the motor heat, and deduct this heat from the gross capacity of the unit.
2. These ratings include the compressor and the condenser fan motors but not the supply air blower motor. The total condenser fan motor power input is 0.36kW. Refer to the SUPPLY AIR BLOWER PERFORMANCE Table for the kW of the supply air blower motor.

NOMINAL RATING

TABLE 5: DM048 COOLING CAPACITIES (4 TON)

AIR ON EVAPORATOR COIL		TEMPERATURE OF AIR ON CONDENSER COIL																			
		85°F								95°F											
		TOTAL CAP. ¹ MBH	POWER INPUT ² kW	SENSIBLE CAPACITY ¹								TOTAL CAP. ¹ MBH	POWER INPUT ² kW	SENSIBLE CAPACITY ¹							
				ENTERING DRY BULB, °F										ENTERING DRY BULB, °F							
CFM	WB °F	86	83	80	77	74	71	68	86	83	80	77	74	71	68						
2000	72	60	4.1	44	39	33	28	23	-	-	60	4.5	44	39	33	28	23	-	-		
	67	55	4.1	53	48	42	37	32	26	21	52	4.5	52	47	42	36	31	25	20		
	62	51	4.0	51	51	51	45	40	34	29	48	4.4	48	48	48	42	37	32	26		
	57	49	3.9	49	49	49	44	39	33	28	47	4.3	47	47	47	42	36	31	26		
1800	72	58	4.1	41	36	31	26	21	-	-	57	4.5	41	36	31	26	21	-	-		
	67	53	4.1	49	45	40	35	30	25	20	50	4.5	49	44	39	34	29	24	19		
	62	49	4.0	49	49	48	43	38	33	28	46	4.4	46	46	46	41	36	31	26		
	57	47	3.9	47	47	47	43	38	33	28	45	4.3	45	45	45	40	36	31	26		
1600	72	56	4.1	38	34	29	25	20	-	-	55	4.6	38	33	29	24	20	-	-		
	67	51	4.1	46	41	37	32	28	24	19	48	4.5	45	40	36	31	27	23	18		
	62	47	4.0	47	47	45	41	36	32	27	44	4.4	44	44	44	40	35	31	26		
	57	46	3.9	46	46	46	41	37	32	28	44	4.4	44	44	44	39	35	30	26		
1400	72	54	4.1	35	31	27	23	19	-	-	53	4.5	35	31	27	23	19	-	-		
	67	49	4.1	42	38	34	30	26	22	19	47	4.5	41	38	34	30	26	22	18		
	62	45	4.0	45	45	42	38	34	30	26	43	4.4	43	43	41	37	33	29	25		
	57	44	3.9	44	44	43	39	35	31	27	42	4.3	42	42	41	37	33	29	25		
1200	72	52	4.1	32	29	25	22	18	-	-	51	4.5	32	28	25	21	18	-	-		
	67	47	4.1	39	35	32	28	25	21	18	45	4.4	38	35	31	28	24	21	17		
	62	43	4.0	43	43	39	36	32	29	25	41	4.3	41	41	38	35	31	28	24		
	57	42	3.9	42	42	39	36	32	29	25	41	4.3	41	41	38	34	31	27	24		

AIR ON EVAPORATOR COIL		TEMPERATURE OF AIR ON CONDENSER COIL																			
		105°F								115°F											
		TOTAL CAP. ¹ MBH	POWER INPUT ² kW	SENSIBLE CAPACITY ¹								TOTAL CAP. ¹ MBH	POWER INPUT ² kW	SENSIBLE CAPACITY ¹							
				ENTERING DRY BULB, °F										ENTERING DRY BULB, °F							
CFM	WB °F	86	83	80	77	74	71	68	86	83	80	77	74	71	68						
2000	72	56	5.1	42	37	31	26	21	-	-	53	5.6	40	35	29	24	19	-	-		
	67	49	5.0	49	46	40	35	29	24	19	46	5.5	46	44	39	33	28	23	17		
	62	45	4.9	45	45	45	39	34	28	23	41	5.4	41	41	41	36	30	25	20		
	57	44	4.9	44	44	44	39	33	28	22	41	5.4	41	41	41	35	30	25	19		
1800	72	55	5.0	39	34	29	24	20	-	-	52	5.5	38	33	28	23	18	-	-		
	67	48	5.0	47	43	38	33	28	23	18	45	5.4	45	42	37	32	27	22	17		
	62	43	4.9	43	43	43	38	33	28	23	40	5.4	40	40	40	35	30	26	21		
	57	43	4.9	43	43	43	38	33	28	23	40	5.4	40	40	40	35	30	25	20		
1600	72	53	5.0	36	32	28	23	19	-	-	51	5.5	35	31	26	22	17	-	-		
	67	46	4.9	44	40	35	31	26	22	17	44	5.4	44	39	35	30	26	21	17		
	62	42	4.9	42	42	42	37	33	28	24	39	5.3	39	39	39	35	30	26	21		
	57	41	4.8	41	41	41	37	32	28	23	39	5.3	39	39	39	34	30	25	21		
1400	72	51	5.0	33	29	26	22	18	-	-	48	5.5	32	28	24	20	16	-	-		
	67	44	4.9	41	37	33	29	25	21	17	42	5.3	40	36	32	28	24	20	16		
	62	40	4.8	40	40	39	35	31	27	23	37	5.3	37	37	36	32	28	24	20		
	57	40	4.8	40	40	38	34	30	26	22	37	5.3	37	37	36	32	28	24	20		
1200	72	49	4.9	30	27	23	20	16	-	-	46	5.4	29	26	22	19	15	-	-		
	67	42	4.9	37	34	30	27	23	20	16	39	5.3	36	33	29	26	22	19	15		
	62	38	4.8	38	38	36	32	29	25	22	35	5.3	35	35	33	29	26	22	19		
	57	38	4.8	38	38	35	32	28	25	21	35	5.3	35	35	33	29	26	22	19		

1. These capacities are gross ratings. For net capacity, determine the kW of the supply air blower motor from the SUPPLY AIR BLOWER PERFORMANCE Table, multiply this value by 3.415 MBH/kW to determine the motor heat, and deduct this heat from the gross capacity of the unit.
2. These ratings include the compressor and the condenser fan motors but not the supply air blower motor. The total condenser fan motor power input is 0.36kW. Refer to the SUPPLY AIR BLOWER PERFORMANCE Table for the kW of the supply air blower motor.

NOMINAL RATING

TABLE 6: DM060 COOLING CAPACITIES (5 TON)

AIR ON EVAPORATOR COIL		TEMPERATURE OF AIR ON CONDENSER COIL																			
		85°F								95°F											
		TOTAL CAP. ¹ MBH	POWER INPUT ² kW	SENSIBLE CAPACITY ¹								TOTAL CAP. ¹ MBH	POWER INPUT ² kW	SENSIBLE CAPACITY ¹							
				ENTERING DRY BULB, °F										ENTERING DRY BULB, °F							
CFM	WB °F	86	83	80	77	74	71	68	86	83	80	77	74	71	68						
2500	72	68	4.9	50	44	38	32	25	-	-	65	5.6	50	43	37	31	24	-	-		
	67	62	4.8	62	56	50	43	37	31	24	60	5.3	60	54	48	42	35	29	23		
	62	57	4.7	57	57	57	51	44	38	32	53	5.3	53	53	53	47	41	34	28		
	57	55	4.7	55	55	55	48	42	36	29	51	5.4	51	51	51	44	38	32	25		
2250	72	67	4.9	48	42	36	30	24	-	-	65	5.4	47	41	35	29	23	-	-		
	67	62	4.8	59	53	47	41	35	30	24	59	5.2	57	51	45	40	34	28	22		
	62	56	4.7	56	56	56	50	45	39	33	53	5.2	53	53	53	47	41	35	29		
	57	54	4.7	54	54	54	48	42	36	31	50	5.3	50	50	50	44	39	33	27		
2000	72	66	4.9	45	39	34	29	23	-	-	64	5.3	44	39	33	28	22	-	-		
	67	61	4.8	55	50	44	39	34	28	23	58	5.1	54	48	43	38	32	27	22		
	62	55	4.7	55	55	55	50	45	39	34	52	5.1	52	52	52	47	42	36	31		
	57	53	4.6	53	53	53	48	42	37	32	50	5.2	50	50	50	44	39	34	28		
1750	72	63	4.8	41	36	31	27	22	-	-	61	5.4	40	35	31	26	21	-	-		
	67	58	4.7	51	46	41	36	32	27	22	56	5.1	49	44	39	35	30	25	21		
	62	53	4.6	53	53	51	47	42	37	32	50	5.2	50	50	48	43	39	34	29		
	57	51	4.6	51	51	49	44	40	35	30	47	5.2	47	47	46	41	36	32	27		
1500	72	60	4.8	37	33	29	25	21	-	-	58	5.4	36	32	28	24	20	-	-		
	67	56	4.7	46	42	38	34	30	26	21	53	5.2	44	40	36	32	28	24	20		
	62	51	4.6	51	51	47	43	39	35	31	47	5.2	47	47	44	40	36	32	27		
	57	49	4.6	49	49	45	41	37	33	29	45	5.3	45	45	42	38	34	29	25		

AIR ON EVAPORATOR COIL		TEMPERATURE OF AIR ON CONDENSER COIL																			
		105°F								115°F											
		TOTAL CAP. ¹ MBH	POWER INPUT ² kW	SENSIBLE CAPACITY ¹								TOTAL CAP. ¹ MBH	POWER INPUT ² kW	SENSIBLE CAPACITY ¹							
				ENTERING DRY BULB, °F										ENTERING DRY BULB, °F							
CFM	WB °F	86	83	80	77	74	71	68	86	83	80	77	74	71	68						
2500	72	61	6.1	48	41	35	29	22	-	-	57	6.7	46	39	33	27	20	-	-		
	67	55	5.9	55	52	46	39	33	27	20	50	6.6	50	50	43	37	31	24	18		
	62	49	5.9	49	49	49	42	36	30	23	44	6.5	44	44	44	38	31	25	19		
	57	47	5.9	47	47	47	40	34	28	21	42	6.5	42	42	42	36	30	23	17		
2250	72	61	6.0	45	39	33	28	22	-	-	57	6.6	43	38	32	26	20	-	-		
	67	54	5.9	53	49	44	38	32	26	20	50	6.5	50	47	42	36	30	24	18		
	62	48	5.8	48	48	48	42	37	31	25	44	6.4	44	44	44	38	32	26	20		
	57	46	5.8	46	46	46	40	35	29	23	42	6.4	42	42	42	36	31	25	19		
2000	72	60	6.0	42	37	32	26	21	-	-	57	6.6	41	36	30	25	20	-	-		
	67	54	5.8	52	47	41	36	31	25	20	50	6.5	50	45	40	34	29	24	18		
	62	48	5.7	48	48	48	43	37	32	27	44	6.4	44	44	44	38	33	28	22		
	57	46	5.8	46	46	46	41	35	30	25	42	6.3	42	42	42	37	32	26	21		
1750	72	57	6.0	38	34	29	24	19	-	-	53	6.5	37	32	27	23	18	-	-		
	67	51	5.8	47	42	38	33	28	24	19	46	6.4	45	41	36	31	26	22	17		
	62	45	5.7	45	45	44	39	34	30	25	41	6.3	41	41	39	35	30	25	21		
	57	43	5.8	43	43	42	37	32	28	23	39	6.3	39	39	38	33	29	24	19		
1500	72	54	6.0	34	30	26	22	18	-	-	49	6.5	33	28	24	20	16	-	-		
	67	48	5.8	42	38	34	30	26	22	18	43	6.4	40	36	32	28	24	20	16		
	62	43	5.7	43	43	39	35	31	27	23	38	6.3	38	38	35	31	27	23	19		
	57	41	5.8	41	41	38	34	30	26	21	37	6.2	37	37	34	30	26	22	18		

1. These capacities are gross ratings. For net capacity, determine the kW of the supply air blower motor from the SUPPLY AIR BLOWER PERFORMANCE Table, multiply this value by 3.415 MBH/kW to determine the motor heat, and deduct this heat from the gross capacity of the unit.
 2. These ratings include the compressor and the condenser fan motors but not the supply air blower motor. The total condenser fan motor power input is 0.36kW. Refer to the SUPPLY AIR BLOWER PERFORMANCE Table for the kW of the supply air blower motor.

NOMINAL RATING

TABLE 7: DM072 COOLING CAPACITIES (6 TON)

AIR ON EVAPORATOR COIL		TEMPERATURE OF AIR ON CONDENSER COIL																			
		85°F								95°F											
		TOTAL CAP. ¹ MBH	POWER INPUT ² kW	SENSIBLE CAPACITY ¹								TOTAL CAP. ¹ MBH	POWER INPUT ² kW	SENSIBLE CAPACITY ¹							
				ENTERING DRY BULB, °F										ENTERING DRY BULB, °F							
CFM	WB °F	86	83	80	77	74	71	68	86	83	80	77	74	71	68						
2700	72	80	5.7	63	55	47	40	32	-	-	77	6.3	63	55	47	40	32	-	-		
	67	80	5.7	76	68	60	53	45	37	30	77	6.3	75	68	60	53	45	37	30		
	62	70	5.5	70	70	70	62	55	47	39	71	6.3	71	71	71	63	56	48	40		
	57	68	5.6	68	68	68	60	52	45	37	71	6.3	71	71	71	63	56	48	40		
2550	72	82	5.7	60	53	46	38	31	-	-	76	6.3	60	53	46	39	31	-	-		
	67	82	5.7	73	65	58	51	43	36	29	76	6.3	73	66	58	51	44	36	29		
	62	71	5.5	71	71	70	62	55	48	41	70	6.3	70	70	69	62	55	48	40		
	57	69	5.6	69	69	69	62	55	47	40	70	6.3	70	70	70	62	55	48	40		
2400	72	83	5.7	58	51	44	37	30	-	-	75	6.3	58	51	44	37	30	-	-		
	67	83	5.7	70	63	56	49	42	35	28	75	6.3	70	64	57	50	43	36	29		
	62	73	5.5	73	73	70	63	56	49	42	69	6.3	69	69	68	61	54	47	40		
	57	71	5.6	71	71	71	64	57	50	43	69	6.3	69	69	68	61	54	47	40		
2100	72	79	5.7	54	48	41	35	29	-	-	73	6.3	53	47	41	35	29	-	-		
	67	79	5.7	65	59	53	47	40	34	28	73	6.3	65	59	52	46	40	34	28		
	62	69	5.5	69	69	66	60	54	47	41	67	6.3	67	66	63	57	51	45	38		
	57	67	5.6	67	67	67	61	54	48	42	67	6.3	67	66	63	57	51	45	39		
1800	72	74	5.6	50	44	39	34	28	-	-	71	6.3	49	43	38	33	27	-	-		
	67	74	5.6	60	55	50	44	39	34	28	71	6.3	59	54	48	43	38	32	27		
	62	65	5.4	65	65	62	57	51	46	41	65	6.2	65	63	58	53	47	42	37		
	57	63	5.5	63	63	63	58	52	47	42	65	6.3	65	63	58	53	47	42	37		

AIR ON EVAPORATOR COIL		TEMPERATURE OF AIR ON CONDENSER COIL																			
		105°F								115°F											
		TOTAL CAP. ¹ MBH	POWER INPUT ² kW	SENSIBLE CAPACITY ¹								TOTAL CAP. ¹ MBH	POWER INPUT ² kW	SENSIBLE CAPACITY ¹							
				ENTERING DRY BULB, °F										ENTERING DRY BULB, °F							
CFM	WB °F	86	83	80	77	74	71	68	86	83	80	77	74	71	68						
2700	72	76	7.1	61	53	45	38	30	-	-	75	7.9	59	51	43	36	28	-	-		
	67	71	7.1	70	66	58	50	43	35	27	65	7.8	65	64	56	48	41	33	25		
	62	64	7.0	64	64	64	56	49	41	34	57	7.8	57	57	57	50	42	34	27		
	57	64	7.0	64	64	64	56	49	41	34	57	7.7	57	57	57	50	42	34	27		
2550	72	76	7.1	59	51	44	37	29	-	-	76	7.9	57	49	42	35	27	-	-		
	67	71	7.1	69	64	56	49	42	34	27	66	7.9	66	61	54	47	40	32	25		
	62	64	7.0	64	64	64	56	49	42	35	58	7.8	58	58	58	51	43	36	29		
	57	64	7.0	64	64	64	56	49	42	34	58	7.7	58	58	58	50	43	36	29		
2400	72	75	7.1	56	49	43	36	29	-	-	76	8.0	55	48	41	34	27	-	-		
	67	70	7.1	68	61	54	48	41	34	27	66	7.9	66	59	52	45	38	32	25		
	62	64	7.0	64	64	63	56	49	42	35	59	7.8	59	59	59	52	45	38	31		
	57	64	7.0	64	64	63	56	49	42	35	59	7.7	59	59	58	51	44	37	30		
2100	72	73	7.1	52	45	39	33	27	-	-	73	7.9	50	44	37	31	25	-	-		
	67	68	7.1	63	56	50	44	38	32	26	63	7.8	61	54	48	42	36	30	24		
	62	61	7.0	61	61	58	52	46	40	34	56	7.7	56	56	54	48	42	35	29		
	57	61	7.0	61	61	58	52	46	40	34	56	7.7	56	56	53	47	41	35	29		
1800	72	70	7.1	47	41	36	31	25	-	-	69	7.8	45	40	34	29	23	-	-		
	67	65	7.0	57	51	46	41	35	30	25	60	7.8	55	49	44	39	33	28	23		
	62	59	7.0	59	58	54	48	43	38	32	53	7.7	53	53	49	44	39	33	28		
	57	59	6.9	59	58	53	48	43	37	32	53	7.6	53	53	49	44	38	33	27		

1. These capacities are gross ratings. For net capacity, determine the kW of the supply air blower motor from the SUPPLY AIR BLOWER PERFORMANCE Table, multiply this value by 3.415 MBH/kW to determine the motor heat, and deduct this heat from the gross capacity of the unit.
 2. These ratings include the compressor and the condenser fan motors but not the supply air blower motor. The total condenser fan motor power input is 0.36kW. Refer to the SUPPLY AIR BLOWER PERFORMANCE Table for the kW of the supply air blower motor.

NOMINAL RATING

TABLE 8: SUPPLY AIR BLOWER PERFORMANCE (3 TON BELT DRIVE) - SIDE DUCT APPLICATION

UNIT SIZE (MBH)	AIR FLOW CFM	AVAILABLE EXTERNAL STATIC PRESSURE-IWG ³													
		0.20		0.30		0.40		0.50		0.60		0.70		0.80	
		RPM	WATTS	RPM	WATTS	RPM	WATTS	RPM	WATTS	RPM	WATTS	RPM	WATTS	RPM	WATTS
036 ^{1,2}	1700	835	705	880	745	923	795	969	860	1013	970	-	-	-	-
	1600	811	655	854	695	898	740	942	790	986	840	1029	900	-	-
	1500	782	610	827	650	871	685	917	730	960	775	1003	825	1046	905
	1400	-	-	798	595	844	640	889	680	932	720	975	765	1018	790
	1300	-	-	-	-	816	590	862	635	907	675	951	715	995	750
	1200	-	-	-	-	-	-	834	585	881	630	927	665	970	705
	1100	-	-	-	-	-	-	809	550	855	590	900	625	942	665
	1000	-	-	-	-	-	-	782	510	829	545	872	858	919	625
900	-	-	-	-	-	-	-	-	797	500	843	540	890	580	

UNIT SIZE (MBH)	AIR FLOW CFM	AVAILABLE EXTERNAL STATIC PRESSURE-IWG ³													
		0.90		1.00		1.10		1.20		1.30		1.40		1.50	
		RPM	WATTS	RPM	WATTS	RPM	WATTS	RPM	WATTS	RPM	WATTS	RPM	WATTS	RPM	WATTS
036 ^{1,2}	1700	-	-	-	-	-	-	-	-	-	-	-	-	-	-
	1600	-	-	-	-	-	-	-	-	-	-	-	-	-	-
	1500	-	-	-	-	-	-	-	-	-	-	-	-	-	-
	1400	1055	875	-	-	-	-	-	-	-	-	-	-	-	-
	1300	1036	780	1066	850	-	-	-	-	-	-	-	-	-	-
	1200	1011	735	1047	765	1075	800	-	-	-	-	-	-	-	-
	1100	987	690	1028	720	1060	750	1084	775	-	-	-	-	-	-
	1000	963	655	1005	680	1040	695	1068	715	1089	735	-	-	-	-
900	936	615	980	645	1020	660	1050	670	1053	680	1090	690	-	-	

1. 230/460/575 Volts

2. For 208 Volts multiply values by 0.95.

3. Includes allowances for a wet evaporator coil, 1" filters, and the heat exchangers. Refer to ACCESSORY STATIC RESISTANCE Table for resistance values on applications other than gas / electric units with side duct airflows.

TABLE 9: SUPPLY AIR BLOWER PERFORMANCE (4 TON BELT DRIVE) - SIDE DUCT APPLICATION

UNIT SIZE (MBH)	AIR FLOW CFM	AVAILABLE EXTERNAL STATIC PRESSURE-IWG ³													
		0.20		0.30		0.40		0.50		0.60		0.70		0.80	
		RPM	WATTS	RPM	WATTS	RPM	WATTS	RPM	WATTS	RPM	WATTS	RPM	WATTS	RPM	WATTS
048 ^{1,2}	2000	843	860	880	925	919	1005	956	1065	993	1145	1030	1195	1067	1235
	1900	817	775	854	850	893	920	930	995	970	1065	1008	1125	1046	1170
	1800	790	700	828	760	867	840	906	905	944	980	985	1040	1025	1100
	1700	-	-	802	670	840	745	881	815	920	900	961	970	1001	1030
	1600	-	-	-	-	818	665	858	740	898	820	940	890	980	950
	1500	-	-	-	-	-	-	842	695	882	755	922	835	962	895
	1400	-	-	-	-	-	-	833	650	867	705	904	765	942	820
	1300	-	-	-	-	-	-	-	-	858	665	893	725	932	785
1200	-	-	-	-	-	-	-	-	847	640	880	680	916	730	

UNIT SIZE (MBH)	AIR FLOW CFM	AVAILABLE EXTERNAL STATIC PRESSURE-IWG ³													
		0.90		1.00		1.10		1.20		1.30		1.40		1.50	
		RPM	WATTS	RPM	WATTS	RPM	WATTS	RPM	WATTS	RPM	WATTS	RPM	WATTS	RPM	WATTS
048 ^{1,2}	2000	1103	1270	-	-	-	-	-	-	-	-	-	-	-	-
	1900	1085	1210	-	-	-	-	-	-	-	-	-	-	-	-
	1800	1064	1145	1102	1180	-	-	-	-	-	-	-	-	-	-
	1700	1040	1075	1081	1115	1121	1140	-	-	-	-	-	-	-	-
	1600	1020	1005	1060	1050	1100	1085	-	-	-	-	-	-	-	-
	1500	1003	945	1044	995	1086	1035	-	-	-	-	-	-	-	-
	1400	982	880	1024	920	1067	965	1107	1000	-	-	-	-	-	-
	1300	970	835	1010	870	1053	920	1099	960	-	-	-	-	-	-
1200	953	780	992	815	1034	855	1080	905	-	-	-	-	-	-	

1. 230/460/575 Volts

2. For 208 Volts multiply values by 0.95.

3. Includes allowances for a wet evaporator coil, 1" filters, and the heat exchangers. Refer to ACCESSORY STATIC RESISTANCE Table for resistance values on applications other than gas / electric units with side duct airflows.

TABLE 10: SUPPLY AIR BLOWER PERFORMANCE (5 TON BELT DRIVE) - SIDE DUCT APPLICATION

UNIT SIZE (MBH)	AIR FLOW CFM	AVAILABLE EXTERNAL STATIC PRESSURE-IWG ³													
		0.20		0.30		0.40		0.50		0.60		0.70		0.80	
		RPM	WATTS	RPM	WATTS	RPM	WATTS	RPM	WATTS	RPM	WATTS	RPM	WATTS	RPM	WATTS
060 ¹²	2500	1059	1560	1077	1590	1095	1630	1114	1650	1134	1660	1158	1685	1181	1720
	2400	1032	1405	1054	1470	1074	1525	1094	1560	1116	1595	1140	1620	1167	1640
	2300	1005	1260	1024	1275	1049	1370	1069	1440	1090	1475	1116	1505	1142	1535
	2200	980	1160	1002	1170	1022	1190	1044	1250	1066	1350	1090	1410	1117	1440
	2100	930	1060	957	1070	983	1080	1010	1100	1039	1160	1064	1260	1092	1340
	2000	877	950	908	975	941	1000	976	1020	1009	1050	1040	1100	1070	1225
	1900	-	-	-	-	894	885	940	940	980	980	1014	1020	1047	1095
	1800	-	-	-	-	855	815	903	860	950	905	988	940	1022	970
	1700	-	-	-	-	-	-	884	815	925	850	964	880	1001	910
	1600	-	-	-	-	-	-	864	770	908	805	948	835	987	870
1500	-	-	-	-	-	-	-	-	882	740	926	780	965	830	

UNIT SIZE (MBH)	AIR FLOW CFM	AVAILABLE EXTERNAL STATIC PRESSURE-IWG ³													
		0.90		1.00		1.10		1.20		1.30		1.40		1.50	
		RPM	WATTS	RPM	WATTS	RPM	WATTS	RPM	WATTS	RPM	WATTS	RPM	WATTS	RPM	WATTS
060 ¹²	2500	-	-	-	-	-	-	-	-	-	-	-	-	-	-
	2400	1193	1665	-	-	-	-	-	-	-	-	-	-	-	-
	2300	1170	1580	1202	1620	-	-	-	-	-	-	-	-	-	-
	2200	1148	1480	1180	1530	-	-	-	-	-	-	-	-	-	-
	2100	1121	1385	1155	1425	1190	1475	-	-	-	-	-	-	-	-
	2000	1100	1285	1133	1340	1169	1385	1205	1445	-	-	-	-	-	-
	1900	1079	1180	1110	1240	1143	1280	1178	1330	1222	1375	-	-	-	-
	1800	1058	1060	1090	1135	1122	1190	1158	1240	1196	1295	-	-	-	-
	1700	1035	960	1071	1030	1103	1100	1134	1140	1164	1175	1197	1205	-	-
	1600	1020	900	1056	965	1088	1035	1118	1065	1145	1105	1170	1130	1198	1150
1500	1004	860	1038	880	1070	925	1101	980	1130	1045	1158	1075	1184	1110	

1. 230/460/575 Volts

2. For 208 Volts multiply values by 0.95.

3. Includes allowances for a wet evaporator coil, 1" filters, and the heat exchangers. Refer to ACCESSORY STATIC RESISTANCE Table for resistance values on applications other than gas / electric units with side duct airflows.

TABLE 11: SUPPLY AIR BLOWER PERFORMANCE (6 TON BELT DRIVE) - SIDE DUCT APPLICATION

UNIT SIZE (MBH)	AIR FLOW CFM	AVAILABLE EXTERNAL STATIC PRESSURE-IWG ³													
		0.20		0.30		0.40		0.50		0.60		0.70		0.80	
		RPM	WATTS	RPM	WATTS	RPM	WATTS	RPM	WATTS	RPM	WATTS	RPM	WATTS	RPM	WATTS
072 ^{1,2}	3200	1150	2325	1182	2425	1212	2525	-	-	-	-	-	-	-	-
	3000	1100	2010	1129	2090	1157	2150	1185	2225	1215	2290	1242	2360	-	-
	2800	1045	1700	1074	1780	1102	1850	1131	1940	1160	2025	1190	2075	1217	2130
	2600	985	1425	1015	1475	1045	1540	1075	1630	1103	1715	1135	1760	1163	1825
	2400	930	1240	958	1300	990	1350	1020	1400	1051	1430	1081	1490	1111	1600
	2200	-	-	905	1070	933	1160	965	1210	997	1250	1028	1285	1060	1325
	2000	-	-	-	-	-	-	919	1025	950	1100	982	1130	1014	1160
1800	-	-	-	-	-	-	-	-	909	925	939	1005	968	1030	

UNIT SIZE (MBH)	AIR FLOW CFM	AVAILABLE EXTERNAL STATIC PRESSURE-IWG ³													
		0.90		1.00		1.10		1.20		1.30		1.40		1.50	
		RPM	WATTS	RPM	WATTS	RPM	WATTS	RPM	WATTS	RPM	WATTS	RPM	WATTS	RPM	WATTS
072 ^{1,2}	3200	-	-	-	-	-	-	-	-	-	-	-	-	-	-
	3000	-	-	-	-	-	-	-	-	-	-	-	-	-	-
	2800	1245	2190	-	-	-	-	-	-	-	-	-	-	-	-
	2600	1193	1920	1222	1990	1250	2060	-	-	-	-	-	-	-	-
	2400	1142	1675	1173	1730	1205	1800	1234	1885	-	-	-	-	-	-
	2200	1090	1380	1124	1450	1155	1550	1186	1640	1217	1710	1249	1775	-	-
	2000	1045	1175	1077	1200	1109	1275	1140	1360	1170	1460	1205	1545	1235	1600
1800	998	1050	1028	1060	1058	1060	1087	1075	1118	1150	1148	1250	1176	1360	

1. 230/460/575 Volts

2. For 208 Volts multiply values by 0.95.

3. Includes allowances for a wet evaporator coil, 1" filters, and the heat exchangers. Refer to ACCESSORY STATIC RESISTANCE Table for resistance values on applications other than gas / electric units with side duct airflows.

TABLE 12: SUPPLY AIR BLOWER PERFORMANCE (3 - 6 TON DIRECT DRIVE) - SIDE DUCT APPLICATION

UNIT SIZE (MBH)	MOTOR SPEED	AVAILABLE EXTERNAL STATIC PRESSURE-IWG ²									
		0.20		0.30		0.40		0.50		0.60	
		CFM	WATTS	CFM	WATTS	CFM	WATTS	CFM	WATTS	CFM	WATTS
036 ¹	HI	-	-	-	-	1699	825	1650	785	1570	755
	MED	1684	800	1631	780	1582	750	1524	720	1410	690
	LOW	1487	710	1464	690	1421	670	1367	650	1315	620
048 ¹	HI	1996	960	1933	936	1868	910	1795	880	1722	845
	MED	1804	838	1765	810	1714	785	1650	765	1589	735
	LOW	1681	760	1640	738	1604	715	1541	695	1490	670
060 ¹	HI	2400	1155	2338	1125	2274	1095	2167	1045	2096	1010
	MED	2290	1105	2214	1065	2145	1030	2071	990	1990	950
	LOW	2150	1020	2100	990	2029	950	1965	910	1905	880
072 ¹	HI	2461	1480	2402	1440	2361	1395	2260	1350	2178	1305

UNIT SIZE (MBH)	MOTOR SPEED	AVAILABLE EXTERNAL STATIC PRESSURE-IWG ²							
		0.70		0.80		0.90		1.00	
		CFM	WATTS	CFM	WATTS	CFM	WATTS	CFM	WATTS
036 ¹	HI	1430	725	1360	700	1280	680	1180	655
	MED	1324	650	1260	630	1185	610	1100	590
	LOW	1246	605	1185	590	1110	570	1020	545
048 ¹	HI	1635	820	1544	790	1419	765	1300	740
	MED	1508	705	1407	675	1306	645	1195	625
	LOW	1416	645	1337	620	1230	595	1120	575
060 ¹	HI	1990	980	1887	945	1771	905	1629	855
	MED	1911	920	1828	885	1724	835	1604	798
	LOW	1816	838	1724	800	1644	770	1531	710
072 ¹	HI	2101	1260	2000	1205	1914	1155	1830	1110

1. Side Duct application (230/460/575 Volts)

2. Includes allowances for a wet evaporator coil, 1" filters, and the heat exchangers. Refer to STATIC RESISTANCES Table for resistance values

TABLE 13: BELT DRIVE BLOWER MOTOR AND DRIVE DATA

MODEL SIZE	BLOWER RANGE (RPM)	MOTOR ¹		ADJUSTABLE MOTOR PULLEY				FIXED BLOWER PULLEY				BELT (NOTCHED)		
		HP	FRAME	DESIG-NATION	OUTSIDE DIA. (IN.)	PITCH DIA. (IN.)	BORE (IN.)	DESIG-NATION	OUTSIDE DIA. (IN.)	PITCH DIA. (IN.)	BORE (IN.)	DESIG-NATION	PITCH LENGTH (IN.)	QTY.
3 TON	790/1120	1 1/2	56	1VL40	2.7-3.7	2.4-3.4	5/8	AK61	5.9	5.7	1	A36	37.3	1
4 TON	790/1120	1 1/2	56	1VL40	2.7-3.7	2.4-3.4	5/8	AK61	5.9	5.7	1	A36	37.3	1
5 TON	850/1220	1 1/2	56	1VL40	2.7-3.7	2.4-3.4	5/8	AK56	5.4	5.2	1	A36	37.3	1
6 TON	900/1250	1 1/2	56	1VL44	3.1-4.1	2.8-3.8	7/8	AK56	5.4	5.2	1	A36	37.3	1

1. All motors have solid bases and are inherently protected. these motors can be selected to operate into their service factor because they are located in the moving air, upstream of any heating device.

TABLE 14: STATIC RESISTANCES

DESCRIPTION		RESISTANCE, IWG										
		CFM										
		1000	1200	1400	1600	1800	2000	2200	2400	2600	2800	3000
ECONOMIZER ^{1,2}		0.07	0.08	0.09	0.11	0.13	0.15	0.17	0.20	0.23	0.26	0.30
ELECTRIC HEATERS ³	5-15KW	0.04	0.05	0.06	0.07	0.08	0.10	0.12	0.14	0.16	0.19	0.22
	20-30KW	0.06	0.07	0.08	0.09	0.11	0.13	0.15	0.17	0.20	0.23	0.26
BOTTOM DUCT CONNECTIONS ¹		0.06	0.07	0.08	0.09	0.10	0.11	0.12	0.14	0.16	0.19	0.22
COOLING ONLY ²		0.08	0.10	0.12	0.14	0.16	0.18	0.20	0.23	0.26	0.29	0.32

1. Deduct these resistance values from the available external static pressure shown in SUPPLY AIR BLOWER PERFORMANCE Tables.
2. The pressure through the economizer is greater for 100% outdoor air than for 100% return air. If the resistance of the return air duct system is less than 0.25 IWG, the unit will deliver less CFM during full economizer operation.
3. Add these resistance values to the available static resistance values on SUPPLY AIR BLOWER PERFORMANCE Tables.

TABLE 15: ELECTRIC HEATER CFM LIMITATIONS

UNIT MODEL SIZE NOMINAL TONS	VOLTAGE	MINIMUM SUPPLY AIR CFM					
		HEATER SIZE NOMINAL KW					
		5	7	10	15	20	30
3	208/230-1-60	1100	1100	1200	1200	1300	-
	208/230-3-60	1100	1100	1200	1200	1300	-
	460-3-60	-	1100	1200	1200	1300	-
	575-3-60	-	-	1200	1200	1300	-
4	208/230-1-60	1300	1300	1300	1300	1300	-
	208/230-3-60	1300	1300	1300	1300	1300	-
	460-3-60	-	1300	1300	1300	1300	-
	575-3-60	-	-	1300	1300	1400	-
5	208/230-1-60	1600	1600	1600	1600	1600	1600
	208/230-3-60	1600	1600	1600	1600	1600	1600
	460-3-60	-	1600	1600	1600	1600	1600
	575-3-60	-	-	1600	1600	1600	1800
6	208/230-1-60	1800	1800	1800	1800	1800	1800
	208/230-3-60	1800	1800	1800	1800	1800	1800
	460-3-60	-	1800	1800	1800	1800	1800
	575-3-60	-	-	1800	1800	1800	1800

TABLE 16: ELECTRICAL DATA - DM036 & 048 DIRECT DRIVE WITHOUT POWR'D CONVENIENCE OUTLET

Model Tonnage	Voltage	Compressors		OD Fan Motor FLA	ID Blower Motor FLA	Conv Outlet Amps	Electric Heater Model No.	Heater kW	Heater Amps	Minimum Circuit Ampacity	Max Fuse / BRKR ¹ Size Amps						
		RLA Each	LRA Each														
3	208-1-60	19.2	87	2.3	4.4	0.0	NONE	0.0	0.0	30.7	45						
							2CE04510506	4.0	19.2	30.7	45						
							2CE04510706	5.6	26.9	39.2	45						
							2CE04511006	8.0	38.5	53.6	60						
							2CE04511506	11.9	57.2	77.0	80						
							2CE04512006	15.9	76.4	101.1	110						
	230-1-60	19.2	87	2.3	4.4	0.0	NONE	0.0	0.0	30.7	45						
							2CE04510506	5.3	22.1	33.1	45						
							2CE04510706	7.5	31.3	44.6	45						
							2CE04511006	10.6	44.2	60.7	70						
							2CE04511506	15.9	66.3	88.3	90						
							2CE04512006	21.2	88.3	115.9	125						
	208-3-60	14.1	110	2.3	4.4	0.0	NONE	0.0	0.0	24.3	35						
							2CE04510525 ²	4.0	11.1	24.3	35						
							2CE04510725 ²	5.6	15.5	24.9	35						
							2CE04511025	8.0	22.2	33.3	35						
							2CE04511525	11.9	33.0	46.8	50						
							2CE04512025	15.9	44.1	60.7	70						
230-3-60	14.1	110	2.3	4.4	0.0	NONE	0.0	0.0	24.3	35							
						2CE04510525	5.3	12.7	24.3	35							
						2CE04510525 ²	7.5	18.0	28.1	35							
						2CE04510725 ²	10.6	25.5	37.4	40							
						2CE04511525	15.9	38.2	53.3	60							
						2CE04512025	21.2	51.0	69.2	70							
460-3-60	7.1	54	1.3	2.2	0.0	NONE	0.0	0.0	12.4	15							
						2CE04510746 ²	6.8	8.2	13.0	15							
						2CE04511046 ²	10.1	12.1	17.9	20							
						2CE04511546 ²	13.6	16.4	23.2	25							
						2CE04512046 ²	19.5	23.5	32.1	35							
						2CE04512058	21.2	20.4	27.7	30							
575-3-60	5.8	44	1.3	2.2	0.0	NONE	0.0	0.0	10.1	15							
						2CE04511058	10.6	10.2	14.9	15							
						2CE04511558	15.9	15.3	21.3	25							
						2CE04512058	21.2	20.4	27.7	30							
						4	208-1-60	25.0	135	2.3	5.0	0.0	NONE	0.0	0.0	38.5	60
													2CE04510506	4.0	19.2	38.5	60
2CE04510706	5.6	26.9	39.9	60													
2CE04511006	8.0	38.5	54.3	60													
2CE04511506	11.9	57.2	77.8	80													
2CE04512006	15.9	76.4	101.8	110													
230-1-60	25.0	135	2.3	5.0	0.0		NONE	0.0	0.0	38.5	60						
							2CE04510506	5.3	22.1	38.5	60						
							2CE04510706	7.5	31.3	45.3	60						
							2CE04511006	10.6	44.2	61.5	70						
							2CE04511506	15.9	66.3	89.1	90						
							2CE04512006	21.2	88.3	116.7	125						
208-3-60	14.7	130	2.3	5.0	0.0		NONE	0.0	0.0	25.7	40						
							2CE04510525 ²	4.0	11.1	25.7	40						
							2CE04510725 ²	5.6	15.5	25.7	40						
							2CE04511025	8.0	22.2	34.0	40						
							2CE04511525	11.9	33.0	47.5	50						
							2CE04512025	15.9	44.1	61.4	70						
230-3-60	14.7	130	2.3	5.0	0.0	NONE	0.0	0.0	25.7	40							
						2CE04510525 ²	5.3	12.7	25.7	40							
						2CE04510725 ²	7.5	18.0	28.8	40							
						2CE04511025	10.6	25.5	38.1	40							
						2CE04511525	15.9	38.2	54.1	60							
						2CE04512025	21.2	51.0	70.0	70							
460-3-60	7.7	64	1.3	2.2	0.0	NONE	0.0	0.0	13.1	20							
						2CE04510746 ²	6.8	8.2	13.1	20							
						2CE04511046 ²	10.1	12.1	17.9	20							
						2CE04511546 ²	13.6	16.4	23.2	25							
						2CE04512046 ²	19.5	23.5	32.1	35							
						2CE04512058	21.2	20.4	27.7	30							
575-3-60	6.4	52	1.3	2.2	0.0	NONE	0.0	0.0	10.8	15							
						2CE04511058	10.6	10.2	14.9	15							
						2CE04511558	15.9	15.3	21.3	25							
						2CE04512058	21.2	20.4	27.7	30							

1. HACR Type per NEC.
 2. These electric heaters DO NOT include a fuse box. If a fuse box is required to meet a local code (i.e. Chicago), the fuse block accessories 2FB04700825 and 2FB04700846 are available for field installation.

TABLE 17: ELECTRICAL DATA - DM060 & 072 DIRECT DRIVE WITHOUT POWR'D CONVENIENCE OUTLET

Model Tonnage	Voltage	Compressors		OD Fan Motor FLA	ID Blower Motor FLA	Conv Outlet Amps	Electric Heater Model No.	Heater kW	Heater Amps	Minimum Circuit Ampacity Amps	Max Fuse / BRKR ¹ Size Amps
		RLA Each	LRA Each								
5	208-1-60	28.9	165	1.3	6.6	0.0	NONE	0.0	0.0	44.0	70
							2CE04510506	4.0	19.2	44.0	70
							2CE04510706	5.6	26.9	44.0	70
							2CE04511006	8.0	38.5	56.3	70
							2CE04511506	11.9	57.2	79.8	80
							2CE04512006	15.9	76.4	103.8	110
	230-1-60	28.9	165	1.3	6.6	0.0	NONE	0.0	0.0	44.0	70
							2CE04510506	5.3	22.1	44.0	70
							2CE04510706	7.5	31.3	47.3	70
							2CE04511006	10.6	44.2	63.5	70
							2CE04511506	15.9	66.3	91.1	100
							2CE04512006	21.2	88.3	118.7	125
	208-3-60	16.0	125	1.3	6.6	0.0	NONE	0.0	0.0	27.9	40
							2CE04510525 ²	4.0	11.1	27.9	40
							2CE04510725 ²	5.6	15.5	27.9	40
							2CE04511025	8.0	22.2	36.0	40
							2CE04511525	11.9	33.0	49.5	50
							2CE04512025	15.9	44.1	63.4	70
230-3-60	16.0	125	1.3	6.6	0.0	NONE	0.0	0.0	27.9	40	
						2CE04510525 ²	5.3	12.7	27.9	40	
						2CE04510725 ²	7.5	18.0	30.8	40	
						2CE04511025	10.6	25.5	40.1	45	
						2CE04511525	15.9	38.2	56.1	60	
						2CE04512025	21.2	51.0	72.0	80	
460-3-60	8.0	66.5	0.8	3.3	0.0	NONE	0.0	0.0	14.1	20	
						2CE04510746 ²	6.8	8.2	14.3	20	
						2CE04511046 ²	10.1	12.1	19.3	20	
						2CE04511546 ²	13.6	16.4	24.6	25	
						2CE04512046 ²	19.5	23.5	33.4	35	
						2CE04513046 ²	28.8	34.6	47.4	50	
575-3-60	6.4	50	0.8	3.3	0.0	NONE	0.0	0.0	11.3	15	
						2CE04511058	10.6	10.2	16.0	20	
						2CE04511558	15.9	15.3	22.4	25	
						2CE04512058	21.2	20.4	28.8	30	
6	208-3-60	18.9	146	1.3	6.8	0.0	NONE	0.0	0.0	31.7	50
							2CE04510525 ²	4.0	11.1	31.7	50
							2CE04510725 ²	5.6	15.5	31.7	50
							2CE04511025	8.0	22.2	36.3	50
							2CE04511525	11.9	33.0	49.8	50
							2CE04512025	15.9	44.1	63.7	70
	230-3-60	18.9	146	1.3	6.8	0.0	NONE	0.0	0.0	31.7	50
							2CE04510525 ²	5.3	12.7	31.7	50
							2CE04510725 ²	7.5	18.0	31.7	50
							2CE04511025	10.6	25.5	40.4	50
							2CE04511525	15.9	38.2	56.3	60
							2CE04512025	21.2	51.0	72.2	80
	460-3-60	9.5	73	0.8	3.6	0.0	NONE	0.0	0.0	16.3	25
							2CE04510746 ²	6.8	8.2	16.3	25
							2CE04511046 ²	10.1	12.1	19.7	25
							2CE04511546 ²	13.6	16.4	24.9	25
							2CE04512046 ²	19.5	23.5	33.8	35
							2CE04513046 ²	28.8	34.6	47.8	50
575-3-60	7.6	58.4	0.8	3.6	0.0	NONE	0.0	0.0	13.0	15	
						2CE04511058	10.6	10.2	16.3	20	
						2CE04511558	15.9	15.3	22.7	25	
						2CE04512058	21.2	20.4	29.1	30	
						2CE04513058	30.4	29.3	40.2	40	

1. HACR Type per NEC.

2. These electric heaters DO NOT include a fuse box. If a fuse box is required to meet a local code (i.e. Chicago), the fuse block accessories 2FB04700825 and 2FB04700846 are available for field installation.

TABLE 18: ELECTRICAL DATA - DM036 & 048 BELT DRIVE WITHOUT POWR'D CONVENIENCE OUTLET

Model Tonnage	Voltage	Compressors		OD Fan Motor FLA	ID Blower Motor FLA	Conv Outlet Amps	Electric Heater Model No.	Heater kW	Heater Amps	Minimum Circuit Ampacity Amps	Max Fuse / BRKR ¹ Size Amps
		RLA Each	LRA Each								
3	208-1-60	18.0	105	1.3	7.6	0.0	NONE	0.0	0.0	31.4	45
							2CE04510506	4.0	19.2	33.5	45
							2CE04510706	5.6	26.9	43.2	45
							2CE04511006	8.0	38.5	57.6	60
							2CE04511506	11.9	57.2	81.0	90
							2CE04512006	15.9	76.4	105.1	110
	230-1-60	18.0	105	1.3	7.6	0.0	NONE	0.0	0.0	31.4	45
							2CE04510506	5.3	22.1	37.1	45
							2CE04510706	7.5	31.3	48.6	50
							2CE04511006	10.6	44.2	64.7	70
							2CE04511506	15.9	66.3	92.3	100
							2CE04512006	21.2	88.3	119.9	125
	208-3-60	11.4	90	1.3	5.2	0.0	NONE	0.0	0.0	20.8	30
							2CE04510525 ²	4.0	11.1	20.8	30
							2CE04510725 ²	5.6	15.5	25.9	30
							2CE04511025	8.0	22.2	34.3	35
							2CE04511525	11.9	33.0	47.8	50
							2CE04512025	15.9	44.1	61.7	70
230-3-60	11.4	90	1.3	5.2	0.0	NONE	0.0	0.0	20.8	30	
						2CE04510525 ²	5.3	12.7	22.4	30	
						2CE04510725 ²	7.5	18.0	29.1	30	
						2CE04511025	10.6	25.5	38.4	40	
						2CE04511525	15.9	38.2	54.3	60	
						2CE04512025	21.2	51.0	70.2	80	
460-3-60	6.2	45	0.8	2.6	0.0	NONE	0.0	0.0	11.1	15	
						2CE04510746 ²	6.8	8.2	13.5	15	
						2CE04511046 ²	10.1	12.1	18.4	20	
						2CE04511546 ²	13.6	16.4	23.7	25	
						2CE04512046 ²	19.5	23.5	32.6	35	
						NONE	0.0	0.0	8.5	15	
575-3-60	5.0	36	0.8	2	0.0	2CE04511058	10.6	10.2	14.7	15	
						2CE04511558	15.9	15.3	21.1	25	
						2CE04512058	21.2	20.4	27.5	30	
4	208-1-60	24.4	140	1.3	7.6	0.0	NONE	0.0	0.0	39.4	60
							2CE04510506	4.0	19.2	39.4	60
							2CE04510706	5.6	26.9	43.2	60
							2CE04511006	8.0	38.5	57.6	60
							2CE04511506	11.9	57.2	81.0	90
							2CE04512006	15.9	76.4	105.1	110
	230-1-60	24.4	140	1.3	7.6	0.0	NONE	0.0	0.0	39.4	60
							2CE04510506	5.3	22.1	39.4	60
							2CE04510706	7.5	31.3	48.6	60
							2CE04511006	10.6	44.2	64.7	70
							2CE04511506	15.9	66.3	92.3	100
							2CE04512006	21.2	88.3	119.9	125
	208-3-60	14.1	105	1.3	5.2	0.0	NONE	0.0	0.0	24.1	35
							2CE04510525 ²	4.0	11.1	24.1	35
							2CE04510725 ²	5.6	15.5	25.9	35
							2CE04511025	8.0	22.2	34.3	35
							2CE04511525	11.9	33.0	47.8	50
							2CE04512025	15.9	44.1	61.7	70
230-3-60	14.1	105	1.3	5.2	0.0	NONE	0.0	0.0	24.1	35	
						2CE04510525 ²	5.3	12.7	24.1	35	
						2CE04510725 ²	7.5	18.0	29.1	35	
						2CE04511025	10.6	25.5	38.4	40	
						2CE04511525	15.9	38.2	54.3	60	
						2CE04512025	21.2	51.0	70.2	80	
460-3-60	7.1	55	0.8	2.6	0.0	NONE	0.0	0.0	12.3	15	
						2CE04510746 ²	6.8	8.2	13.5	15	
						2CE04511046 ²	10.1	12.1	18.4	20	
						2CE04511546 ²	13.6	16.4	23.7	25	
						2CE04512046 ²	19.5	23.5	32.6	35	
						NONE	0.0	0.0	9.5	15	
575-3-60	5.8	44	0.8	2	0.0	2CE04511058	10.6	10.2	14.7	15	
						2CE04511558	15.9	15.3	21.1	25	
						2CE04512058	21.2	20.4	27.5	30	

1. HACR Type per NEC.
 2. These electric heaters DO NOT include a fuse box. If a fuse box is required to meet a local code (i.e. Chicago), the fuse block accessories 2FB04700825 and 2FB04700846 are available for field installation.

TABLE 19: ELECTRICAL DATA - DM060 & 072 BELT DRIVE WITHOUT POWR'D CONVENIENCE OUTLET

Model Tonnage	Voltage	Compressors		OD Fan Motor FLA	ID Blower Motor FLA	Conv Outlet Amps	Electric Heater Model No.	Heater kW	Heater Amps	Minimum Circuit Ampacity Amps	Max Fuse / BRKR ¹ Size Amps
		RLA Each	LRA Each								
5	208-1-60	28.9	165	1.3	7.6	0.0	NONE	0.0	0.0	45.0	70
							2CE04510506	4.0	19.2	45.0	70
							2CE04510706	5.6	26.9	45.0	70
							2CE04511006	8.0	38.5	57.6	70
							2CE04511506	11.9	57.2	81.0	90
							2CE04512006	15.9	76.4	105.1	110
	2CE04513006	22.2	106.7	142.9	150						
	230-1-60	28.9	165	1.3	7.6	0.0	NONE	0.0	0.0	45.0	70
							2CE04510506	5.3	22.1	45.0	70
							2CE04510706	7.5	31.3	48.6	70
							2CE04511006	10.6	44.2	64.7	70
							2CE04511506	15.9	66.3	92.3	100
							2CE04512006	21.2	88.3	119.9	125
	2CE04513006	29.6	123.3	163.7	175						
	208-3-60	16.0	125	1.3	5.2	0.0	NONE	0.0	0.0	26.5	40
							2CE04510525 ²	4.0	11.1	26.5	40
							2CE04510725 ²	5.6	15.5	26.5	40
							2CE04511025	8.0	22.2	34.3	40
2CE04511525							11.9	33.0	47.8	50	
2CE04512025							15.9	44.1	61.7	70	
2CE04513025	22.2	61.6	83.5	90							
230-3-60	16.0	125	1.3	5.2	0.0	NONE	0.0	0.0	26.5	40	
						2CE04510525 ²	5.3	12.7	26.5	40	
						2CE04510725 ²	7.5	18.0	29.1	40	
						2CE04511025	10.6	25.5	38.4	40	
						2CE04511525	15.9	38.2	54.3	60	
						2CE04512025	21.2	51.0	70.2	80	
2CE04513025	29.6	71.2	95.5	100							
460-3-60	8.0	66.5	0.8	2.6	0.0	NONE	0.0	0.0	13.4	20	
						2CE04510746 ²	6.8	8.2	13.5	20	
						2CE04511046 ²	10.1	12.1	18.4	20	
						2CE04511546 ²	13.6	16.4	23.7	25	
						2CE04512046 ²	19.5	23.5	32.6	35	
						2CE04513046 ²	28.8	34.6	46.6	50	
575-3-60	6.4	50	0.8	2	0.0	NONE	0.0	0.0	10.2	15	
						2CE04511058	10.6	10.2	14.7	15	
						2CE04511558	15.9	15.3	21.1	25	
						2CE04512058	21.2	20.4	27.5	30	
2CE04513058	30.4	29.3	38.6	40							
6	208-3-60	18.9	146	1.3	5.0	0.0	NONE	0.0	0.0	29.9	45
							2CE04510525 ²	4.0	11.1	29.9	45
							2CE04510725 ²	5.6	15.5	29.9	45
							2CE04511025	8.0	22.2	34.0	45
							2CE04511525	11.9	33.0	47.5	50
							2CE04512025	15.9	44.1	61.4	70
	2CE04513025	22.2	61.6	83.3	90						
	230-3-60	18.9	146	1.3	5.0	0.0	NONE	0.0	0.0	29.9	45
							2CE04510525 ²	5.3	12.7	29.9	45
							2CE04510725 ²	7.5	18.0	29.9	45
							2CE04511025	10.6	25.5	38.1	45
							2CE04511525	15.9	38.2	54.1	60
							2CE04512025	21.2	51.0	70.0	70
	2CE04513025	29.6	71.2	95.3	100						
	460-3-60	9.5	73	0.8	2.5	0.0	NONE	0.0	0.0	15.2	20
							2CE04510746 ²	6.8	8.2	15.2	20
							2CE04511046 ²	10.1	12.1	18.3	20
							2CE04511546 ²	13.6	16.4	23.6	25
2CE04512046 ²							19.5	23.5	32.4	35	
2CE04513046 ²							28.8	34.6	46.4	50	
575-3-60	7.6	58.4	0.8	2	0.0	NONE	0.0	0.0	11.7	15	
						2CE04511058	10.6	10.2	14.7	15	
						2CE04511558	15.9	15.3	21.1	25	
						2CE04512058	21.2	20.4	27.5	30	
2CE04513058	30.4	29.3	38.6	40							

1. HACR Type per NEC.

2. These electric heaters DO NOT include a fuse box. If a fuse box is required to meet a local code (i.e. Chicago), the fuse block accessories 2FB04700825 and 2FB04700846 are available for field installation.

TABLE 20: ELECTRICAL DATA - DM036 & 048 DIRECT DRIVE WITH POWR'D CONVENIENCE OUTLET

Model Tonnage	Voltage	Compressors		OD Fan Motor FLA	ID Blower Motor FLA	Conv Outlet Amps	Electric Heater Model No.	Heater kW	Heater Amps	Minimum Circuit Ampacity Amps	Max Fuse / BRKR ¹ Size Amps
		RLA Each	LRA Each								
3	208-1-60	18.0	105	1.3	4.4	10.0	NONE	0.0	0.0	38.2	50
							2CE04510506	4.0	19.2	42.0	50
							2CE04510706	5.6	26.9	51.7	60
							2CE04511006	8.0	38.5	66.1	70
							2CE04511506	11.9	57.2	89.5	90
							2CE04512006	15.9	76.4	113.6	125
	230-1-60	18.0	105	1.3	4.4	10.0	NONE	0.0	0.0	38.2	50
							2CE04510506	5.3	22.1	45.6	50
							2CE04510706	7.5	31.3	57.1	60
							2CE04511006	10.6	44.2	73.2	80
							2CE04511506	15.9	66.3	100.8	110
							2CE04512006	21.2	88.3	128.4	150
	208-3-60	11.4	90	1.3	4.4	10.0	NONE	0.0	0.0	29.9	40
							2CE04510525 ²	4.0	11.1	31.9	40
							2CE04510725 ²	5.6	15.5	37.4	40
							2CE04511025	8.0	22.2	45.8	50
							2CE04511525	11.9	33.0	59.3	60
							2CE04512025	15.9	44.1	73.2	80
230-3-60	11.4	90	1.3	4.4	10.0	NONE	0.0	0.0	29.9	40	
						2CE04510525 ²	5.3	12.7	33.9	40	
						2CE04510725 ²	7.5	18.0	40.6	45	
						2CE04511025	10.6	25.5	49.9	50	
						2CE04511525	15.9	38.2	65.8	70	
						2CE04512025	21.2	51.0	81.7	90	
460-3-60	6.2	45	0.8	2.2	5.0	NONE	0.0	0.0	15.8	20	
						2CE04510746 ²	6.8	8.2	19.2	20	
						2CE04511046 ²	10.1	12.1	24.2	25	
						2CE04511546 ²	13.6	16.4	29.4	30	
						2CE04512046 ²	19.5	23.5	38.3	40	
						NONE	0.0	0.0	12.7	15	
575-3-60	5.0	36	0.8	2.2	4.0	2CE04511058	10.6	10.2	19.9	20	
						2CE04511558	15.9	15.3	26.3	30	
						2CE04512058	21.2	20.4	32.7	35	
4	208-1-60	24.4	140	1.3	5.0	10.0	NONE	0.0	0.0	46.8	70
							2CE04510506	4.0	19.2	46.8	70
							2CE04510706	5.6	26.9	52.4	70
							2CE04511006	8.0	38.5	66.8	70
							2CE04511506	11.9	57.2	90.3	100
							2CE04512006	15.9	76.4	114.3	125
	230-1-60	24.4	140	1.3	5.0	10.0	NONE	0.0	0.0	46.8	70
							2CE04510506	5.3	22.1	46.8	70
							2CE04510706	7.5	31.3	57.8	70
							2CE04511006	10.6	44.2	74.0	80
							2CE04511506	15.9	66.3	101.6	110
							2CE04512006	21.2	88.3	129.2	150
	208-3-60	14.1	105	1.3	5.0	10.0	NONE	0.0	0.0	33.9	45
							2CE04510525 ²	4.0	11.1	33.9	45
							2CE04510725 ²	5.6	15.5	38.2	45
							2CE04511025	8.0	22.2	46.5	50
							2CE04511525	11.9	33.0	60.0	70
							2CE04512025	15.9	44.1	73.9	80
230-3-60	14.1	105	1.3	5.0	10.0	NONE	0.0	0.0	33.9	45	
						2CE04510525 ²	5.3	12.7	34.7	45	
						2CE04510725 ²	7.5	18.0	41.3	45	
						2CE04511025	10.6	25.5	50.6	60	
						2CE04511525	15.9	38.2	66.6	70	
						2CE04512025	21.2	51.0	82.5	90	
460-3-60	7.1	55	0.8	2.2	5.0	NONE	0.0	0.0	16.9	20	
						2CE04510746 ²	6.8	8.2	19.2	20	
						2CE04511046 ²	10.1	12.1	24.2	25	
						2CE04511546 ²	13.6	16.4	29.4	30	
						2CE04512046 ²	19.5	23.5	38.3	40	
						NONE	0.0	0.0	13.7	15	
575-3-60	5.8	44	0.8	2.2	4.0	2CE04511058	10.6	10.2	19.9	20	
						2CE04511558	15.9	15.3	26.3	30	
						2CE04512058	21.2	20.4	32.7	35	

1. HACR Type per NEC.
 2. These electric heaters DO NOT include a fuse box. If a fuse box is required to meet a local code (i.e. Chicago), the fuse block accessories 2FB04700825 and 2FB04700846 are available for field installation.

TABLE 21: ELECTRICAL DATA - DM060 & 072 DIRECT DRIVE WITH POWR'D CONVENIENCE OUTLET

Model Tonnage	Voltage	Compressors		OD Fan Motor FLA	ID Blower Motor FLA	Conv Outlet Amps	Electric Heater Model No.	Heater kW	Heater Amps	Minimum Circuit Ampacity Amps	Max Fuse / BRKR ¹ Size Amps
		RLA Each	LRA Each								
5	208-1-60	28.9	165	1.3	6.6	10.0	NONE	0.0	0.0	54.0	80
							2CE04510506	4.0	19.2	54.0	80
							2CE04510706	5.6	26.9	54.4	80
							2CE04511006	8.0	38.5	68.8	80
							2CE04511506	11.9	57.2	92.3	100
							2CE04512006	15.9	76.4	116.3	125
	2CE04513006	22.2	106.7	154.2	175						
	230-1-60	28.9	165	1.3	6.6	10.0	NONE	0.0	0.0	54.0	80
							2CE04510506	5.3	22.1	54.0	80
							2CE04510706	7.5	31.3	59.8	80
							2CE04511006	10.6	44.2	76.0	80
							2CE04511506	15.9	66.3	103.6	110
							2CE04512006	21.2	88.3	131.2	150
	2CE04513006	29.6	123.3	174.9	175						
	208-3-60	16.0	125	1.3	6.6	10.0	NONE	0.0	0.0	37.9	50
							2CE04510525 ²	4.0	11.1	37.9	50
							2CE04510725 ²	5.6	15.5	40.2	50
							2CE04511025	8.0	22.2	48.5	50
2CE04511525							11.9	33.0	62.0	70	
2CE04512025							15.9	44.1	75.9	80	
2CE04513025	22.2	61.6	97.8	100							
230-3-60	16.0	125	1.3	6.6	10.0	NONE	0.0	0.0	37.9	50	
						2CE04510525 ²	5.3	12.7	37.9	50	
						2CE04510725 ²	7.5	18.0	43.3	50	
						2CE04511025	10.6	25.5	52.6	60	
						2CE04511525	15.9	38.2	68.6	70	
						2CE04512025	21.2	51.0	84.5	90	
2CE04513025	29.6	71.2	109.8	110							
460-3-60	8.0	66.5	0.8	3.3	5.0	NONE	0.0	0.0	19.1	25	
						2CE04510746 ²	6.8	8.2	20.6	25	
						2CE04511046 ²	10.1	12.1	25.6	30	
						2CE04511546 ²	13.6	16.4	30.8	35	
						2CE04512046 ²	19.5	23.5	39.7	40	
						2CE04513046 ²	28.8	34.6	53.7	60	
575-3-60	6.4	50	0.8	3.3	4.0	NONE	0.0	0.0	15.3	20	
						2CE04511058	10.6	10.2	21.0	25	
						2CE04511558	15.9	15.3	27.4	30	
						2CE04512058	21.2	20.4	33.8	35	
2CE04513058	30.4	29.3	44.9	45							
6	208-3-60	18.9	146	1.3	6.8	10.0	NONE	0.0	0.0	41.7	60
							2CE04510525 ²	4.0	11.1	41.7	60
							2CE04510725 ²	5.6	15.5	41.7	60
							2CE04511025	8.0	22.2	48.8	60
							2CE04511525	11.9	33.0	62.3	70
							2CE04512025	15.9	44.1	76.2	80
	2CE04513025	22.2	61.6	98.0	100						
	230-3-60	18.9	146	1.3	6.8	10.0	NONE	0.0	0.0	41.7	60
							2CE04510525 ²	5.3	12.7	41.7	60
							2CE04510725 ²	7.5	18.0	43.6	60
							2CE04511025	10.6	25.5	52.9	60
							2CE04511525	15.9	38.2	68.8	70
							2CE04512025	21.2	51.0	84.7	90
	2CE04513025	29.6	71.2	110.0	125						
	460-3-60	9.5	73	0.8	3.6	5.0	NONE	0.0	0.0	21.3	30
							2CE04510746 ²	6.8	8.2	21.3	30
							2CE04511046 ²	10.1	12.1	25.9	30
							2CE04511546 ²	13.6	16.4	31.2	35
2CE04512046 ²							19.5	23.5	40.1	45	
2CE04513046 ²							28.8	34.6	54.1	60	
575-3-60	7.6	58.4	0.8	3.6	4.0	NONE	0.0	0.0	17.0	20	
						2CE04511058	10.6	10.2	21.3	25	
						2CE04511558	15.9	15.3	27.7	30	
						2CE04512058	21.2	20.4	34.1	35	
2CE04513058	30.4	29.3	45.2	45							

1. HACR Type per NEC.

2. These electric heaters DO NOT include a fuse box. If a fuse box is required to meet a local code (i.e. Chicago), the fuse block accessories 2FB04700825 and 2FB04700846 are available for field installation.

TABLE 22: ELECTRICAL DATA - DM036 & 048 BELT DRIVE WITH POWR'D CONVENIENCE OUTLET

Model Tonnage	Voltage	Compressors		OD Fan Motor FLA	ID Blower Motor FLA	Conv Outlet Amps	Electric Heater Model No.	Heater kW	Heater Amps	Minimum Circuit Ampacity	Max Fuse / BRKR ¹ Size Amps
		RLA Each	LRA Each								
3	208-1-60	18.0	105	1.3	7.6	10.0	NONE	0.0	0.0	41.4	50
							2CE04510506	4.0	19.2	46.0	50
							2CE04510706	5.6	26.9	55.7	60
							2CE04511006	8.0	38.5	70.1	80
							2CE04511506	11.9	57.2	93.5	100
							2CE04512006	15.9	76.4	117.6	125
	230-1-60	18.0	105	1.3	7.6	10.0	NONE	0.0	0.0	41.4	50
							2CE04510506	5.3	22.1	49.6	50
							2CE04510706	7.5	31.3	61.1	70
							2CE04511006	10.6	44.2	77.2	80
							2CE04511506	15.9	66.3	104.8	110
							2CE04512006	21.2	88.3	132.4	150
	208-3-60	11.4	90	1.3	5.2	10.0	NONE	0.0	0.0	30.8	40
							2CE04510525 ²	4.0	11.1	32.9	40
							2CE04510725 ²	5.6	15.5	38.4	40
							2CE04511025	8.0	22.2	46.8	50
							2CE04511525	11.9	33.0	60.3	70
							2CE04512025	15.9	44.1	74.2	80
230-3-60	11.4	90	1.3	5.2	10.0	NONE	0.0	0.0	30.8	40	
						2CE04510525 ²	5.3	12.7	34.9	40	
						2CE04510725 ²	7.5	18.0	41.6	45	
						2CE04511025	10.6	25.5	50.9	60	
						2CE04511525	15.9	38.2	66.8	70	
						2CE04512025	21.2	51.0	82.7	90	
460-3-60	6.2	45	0.8	2.6	5.0	NONE	0.0	0.0	16.1	20	
						2CE04510746 ²	6.8	8.2	19.7	20	
						2CE04511046 ²	10.1	12.1	24.7	25	
						2CE04511546 ²	13.6	16.4	29.9	30	
						2CE04512046 ²	19.5	23.5	38.8	40	
						NONE	0.0	0.0	12.5	15	
575-3-60	5.0	36	0.8	2	4.0	2CE04511058	10.6	10.2	19.7	20	
						2CE04511558	15.9	15.3	26.1	30	
						2CE04512058	21.2	20.4	32.5	35	
4	208-1-60	24.4	140	1.3	7.6	10.0	NONE	0.0	0.0	49.4	70
							2CE04510506	4.0	19.2	49.4	70
							2CE04510706	5.6	26.9	55.7	70
							2CE04511006	8.0	38.5	70.1	80
							2CE04511506	11.9	57.2	93.5	100
							2CE04512006	15.9	76.4	117.6	125
	230-1-60	24.4	140	1.3	7.6	10.0	NONE	0.0	0.0	49.4	70
							2CE04510506	5.3	22.1	49.6	70
							2CE04510706	7.5	31.3	61.1	70
							2CE04511006	10.6	44.2	77.2	80
							2CE04511506	15.9	66.3	104.8	110
							2CE04512006	21.2	88.3	132.4	150
	208-3-60	14.1	105	1.3	5.2	10.0	NONE	0.0	0.0	34.1	45
							2CE04510525 ²	4.0	11.1	34.1	45
							2CE04510725 ²	5.6	15.5	38.4	45
							2CE04511025	8.0	22.2	46.8	50
							2CE04511525	11.9	33.0	60.3	70
							2CE04512025	15.9	44.1	74.2	80
230-3-60	14.1	105	1.3	5.2	10.0	NONE	0.0	0.0	34.1	45	
						2CE04510525 ²	5.3	12.7	34.9	45	
						2CE04510725 ²	7.5	18.0	41.6	45	
						2CE04511025	10.6	25.5	50.9	60	
						2CE04511525	15.9	38.2	66.8	70	
						2CE04512025	21.2	51.0	82.7	90	
460-3-60	7.1	55	0.8	2.6	5.0	NONE	0.0	0.0	17.3	20	
						2CE04510746 ²	6.8	8.2	19.7	20	
						2CE04511046 ²	10.1	12.1	24.7	25	
						2CE04511546 ²	13.6	16.4	29.9	30	
						2CE04512046 ²	19.5	23.5	38.8	40	
						NONE	0.0	0.0	13.5	15	
575-3-60	5.8	44	0.8	2	4.0	2CE04511058	10.6	10.2	19.7	20	
						2CE04511558	15.9	15.3	26.1	30	
						2CE04512058	21.2	20.4	32.5	35	

1. HACR Type per NEC.
 2. These electric heaters DO NOT include a fuse box. If a fuse box is required to meet a local code (i.e. Chicago), the fuse block accessories 2FB04700825 and 2FB04700846 are available for field installation.

TABLE 23: ELECTRICAL DATA - DM060 & 072 BELT DRIVE WITH POWR'D CONVENIENCE OUTLET

Model Tonnage	Voltage	Compressors		OD Fan Motor FLA	ID Blower Motor FLA	Conv Outlet Amps	Electric Heater Model No.	Heater kW	Heater Amps	Minimum Circuit Ampacity Amps	Max Fuse / BRKR ¹ Size Amps
		RLA Each	LRA Each								
5	208-1-60	28.9	165	1.3	7.6	10.0	NONE	0.0	0.0	55.0	80
							2CE04510506	4.0	19.2	55.0	80
							2CE04510706	5.6	26.9	55.7	80
							2CE04511006	8.0	38.5	70.1	80
							2CE04511506	11.9	57.2	93.5	100
							2CE04512006	15.9	76.4	117.6	125
	2CE04513006	22.2	106.7	155.4	175						
	230-1-60	28.9	165	1.3	7.6	10.0	NONE	0.0	0.0	55.0	80
							2CE04510506	5.3	22.1	55.0	80
							2CE04510706	7.5	31.3	61.1	80
							2CE04511006	10.6	44.2	77.2	80
							2CE04511506	15.9	66.3	104.8	110
							2CE04512006	21.2	88.3	132.4	150
	2CE04513006	29.6	123.3	176.2	200						
	208-3-60	16.0	125	1.3	5.2	10.0	NONE	0.0	0.0	36.5	50
							2CE04510525 ²	4.0	11.1	36.5	50
							2CE04510725 ²	5.6	15.5	38.4	50
							2CE04511025	8.0	22.2	46.8	50
							2CE04511525	11.9	33.0	60.3	70
							2CE04512025	15.9	44.1	74.2	80
	2CE04513025	22.2	61.6	96.0	100						
	230-3-60	16.0	125	1.3	5.2	10.0	NONE	0.0	0.0	36.5	50
							2CE04510525 ²	5.3	12.7	36.5	50
							2CE04510725 ²	7.5	18.0	41.6	50
2CE04511025							10.6	25.5	50.9	60	
2CE04511525							15.9	38.2	66.8	70	
2CE04512025							21.2	51.0	82.7	90	
2CE04513025	29.6	71.2	108.0	110							
460-3-60	8.0	66.5	0.8	2.6	5.0	NONE	0.0	0.0	18.4	25	
						2CE04510746 ²	6.8	8.2	19.7	25	
						2CE04511046 ²	10.1	12.1	24.7	25	
						2CE04511546 ²	13.6	16.4	29.9	30	
						2CE04512046 ²	19.5	23.5	38.8	40	
						2CE04513046 ²	28.8	34.6	52.8	60	
575-3-60	6.4	50	0.8	2	4.0	NONE	0.0	0.0	14.2	20	
						2CE04511058	10.6	10.2	19.7	20	
						2CE04511558	15.9	15.3	26.1	30	
						2CE04512058	21.2	20.4	32.5	35	
						2CE04513058	30.4	29.3	43.6	45	
6	208-3-60	18.9	146	1.3	5.0	10.0	NONE	0.0	0.0	39.9	50
							2CE04510525 ²	4.0	11.1	39.9	50
							2CE04510725 ²	5.6	15.5	39.9	50
							2CE04511025	8.0	22.2	46.5	50
							2CE04511525	11.9	33.0	60.0	70
							2CE04512025	15.9	44.1	73.9	80
	2CE04513025	22.2	61.6	95.8	100						
	230-3-60	18.9	146	1.3	5.0	10.0	NONE	0.0	0.0	39.9	50
							2CE04510525 ²	5.3	12.7	39.9	50
							2CE04510725 ²	7.5	18.0	41.3	50
							2CE04511025	10.6	25.5	50.6	60
							2CE04511525	15.9	38.2	66.6	70
							2CE04512025	21.2	51.0	82.5	90
	2CE04513025	29.6	71.2	107.8	110						
	460-3-60	9.5	73	0.8	2.5	5.0	NONE	0.0	0.0	20.2	25
							2CE04510746 ²	6.8	8.2	20.2	25
							2CE04511046 ²	10.1	12.1	24.6	25
							2CE04511546 ²	13.6	16.4	29.8	30
							2CE04512046 ²	19.5	23.5	38.7	40
							2CE04513046 ²	28.8	34.6	52.7	60
	575-3-60	7.6	58.4	0.8	2	4.0	NONE	0.0	0.0	15.7	20
							2CE04511058	10.6	10.2	19.7	20
							2CE04511558	15.9	15.3	26.1	30
							2CE04512058	21.2	20.4	32.5	35
2CE04513058							30.4	29.3	43.6	45	

1. HACR Type per NEC.
 2. These electric heaters DO NOT include a fuse box. If a fuse box is required to meet a local code (i.e. Chicago), the fuse block accessories 2FB04700825 and 2FB04700846 are available for field installation.

TABLE 24: PHYSICAL DATA

MODELS		DM			
		036	048	060	072
EVAPORATOR BLOWER	Centrifugal Blower (Dia. x Wd. in.)	12 X 10	12 X 10	12 X 10	12 X 11
	Fan Motor HP (Direct Drive)	1/2	3/4	1	1
	Fan Motor HP (Belt Drive)	1 1/2	1 1/2	1 1/2	1 1/2
EVAPORATOR COIL	Rows Deep	3	3	3	4
	Fins Per Inch	13	13	13	13
	Face Area (Sq. Ft.)	3.6	4.3	5.1	5.1
CONDENSER FANS	Propeller Dia. (in.)	24	24	24	24
	Fan Motor Hp	1/4	1/4	1/4	1/4
	Nom. CFM	3400	3400	3400	3400
CONDENSER COILS	Rows Deep	1	1	1	2
	Fins Per Inch	16	16	22	16
	Face Area (Sq. Ft.)	17.1	17.1	17.1	16.7
COMPRESSOR (Qty. Per Unit)	Scroll Type	1	1	1	1
AIR FILTERS	Quantity Per Unit (15" X 20" X 1" or 2")	2	2	2	2
	Quantity Per Unit (14" X 25" X 1" or 2")	1	1	1	1
	Total Face Area (sq. ft.)	6.3	6.3	6.3	6.3
CHARGE	Refrigerant 22 (lbs./oz.)	5/8	6/8	6/8	10/0

TABLE 25: ELECTRIC HEAT CORRECTION FACTORS

NOMINAL VOLTAGE	VOLTAGE	KW CAP. MULTIPLIER
208	208	1.00
240	230	0.92
480	460	0.92
600	575	0.92

TABLE 26: VOLTAGE LIMITATIONS¹

POWER SUPPLY	VOLTAGE	
	MIN.	MAX.
208/230-3-60	187	253
460-3-60	414	506
575-3-60	518	506

1. Utilization Range "A" in accordance with ARI Standard 110.

TYPICAL POWER WIRING

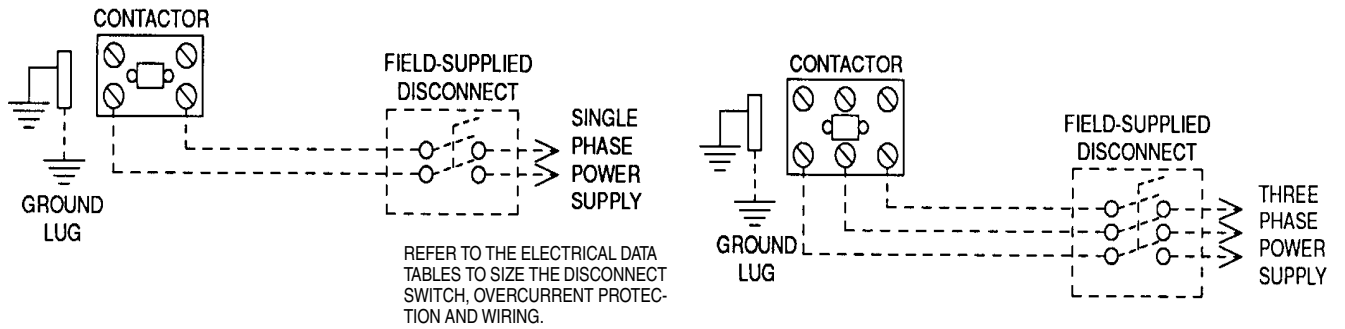

TYPICAL CONTROL WIRING

COOLING ONLY (24 VOLT THERMOSTAT)

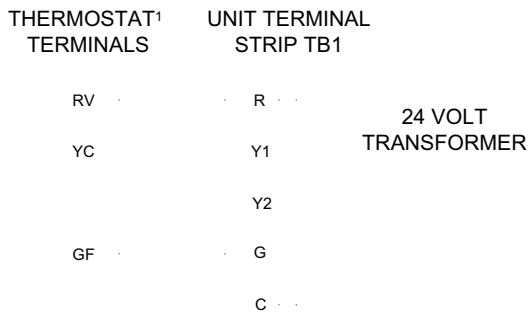

¹ 24 VOLT THERMOSTAT 2TH07701024. TO CONTROL THE ECONOMIZER ON SECOND STAGE COOLING, USE THE THERMOSTAT 2TH0401224.

COOLING / HEATING (24 VOLT THERMOSTAT)

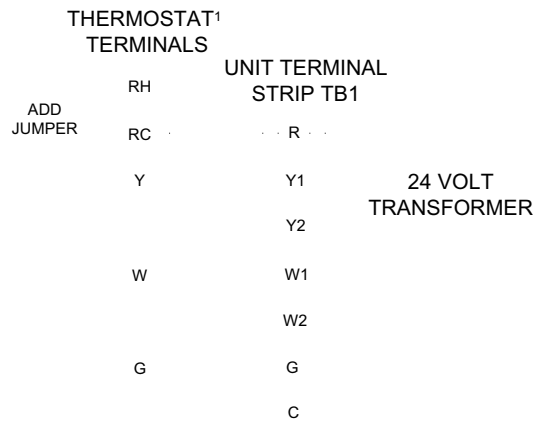

¹ 24 VOLT THERMOSTAT 2ET07701024. TO CONTROL THE ECONOMIZER ON THE SECOND STAGE COOLING OR TO HAVE AN ELECTRIC HEAT ACCESSORY WITH TWO STAGES OF HEAT, USE THERMOSTAT 2TH0471024.

COOLING / HEATING (ELECTRONIC THEROMSTAT) MULTI STAGE

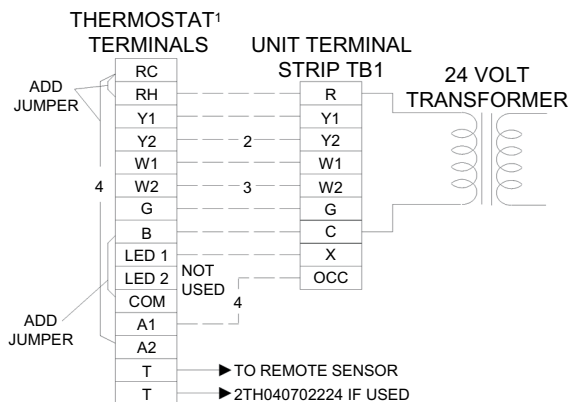

¹ ELECTRONIC PROGRAMMABLE THEROMSTAT 2TH04700224 (INCLUDES SUBBASE).

² SECOND STAGE COOLING IS NOT REQUIRED ON UNITS LESS ECONOMIZER.

³ SECOND STAGE HEATING IS ONLY REQUIRED ON UNITS WITH A TWO STAGE ELECTRIC HEATER.

COOLING / HEATING (ELECTRONIC THEROMSTAT) SINGLE STAGE

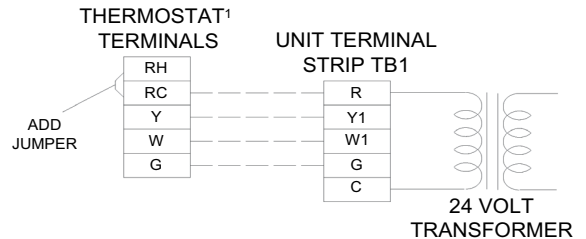

¹ ELECTRONIC PROGRAMMABLE THEROMSTAT 2ET07701024 (INCLUDES SUBBASE). TO CONTROL THE ECONOMIZER ON SECOND STAGE COOLING, USE THERMOSTAT 2TH04700224.

FIGURE 2: TYPICAL FIELD POWER & CONTROL WIRING

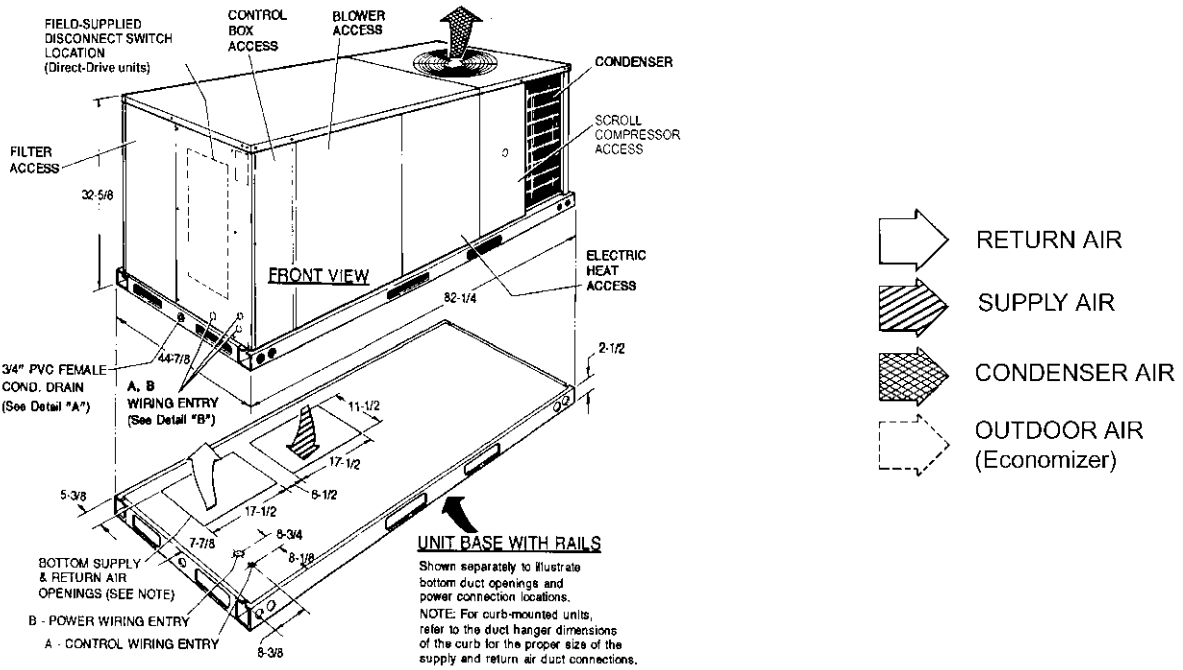

FIGURE 3: UNIT DIMENSIONS (3 - 6 TON COOLING ONLY/ELECTRIC HEAT) FRONT VIEW

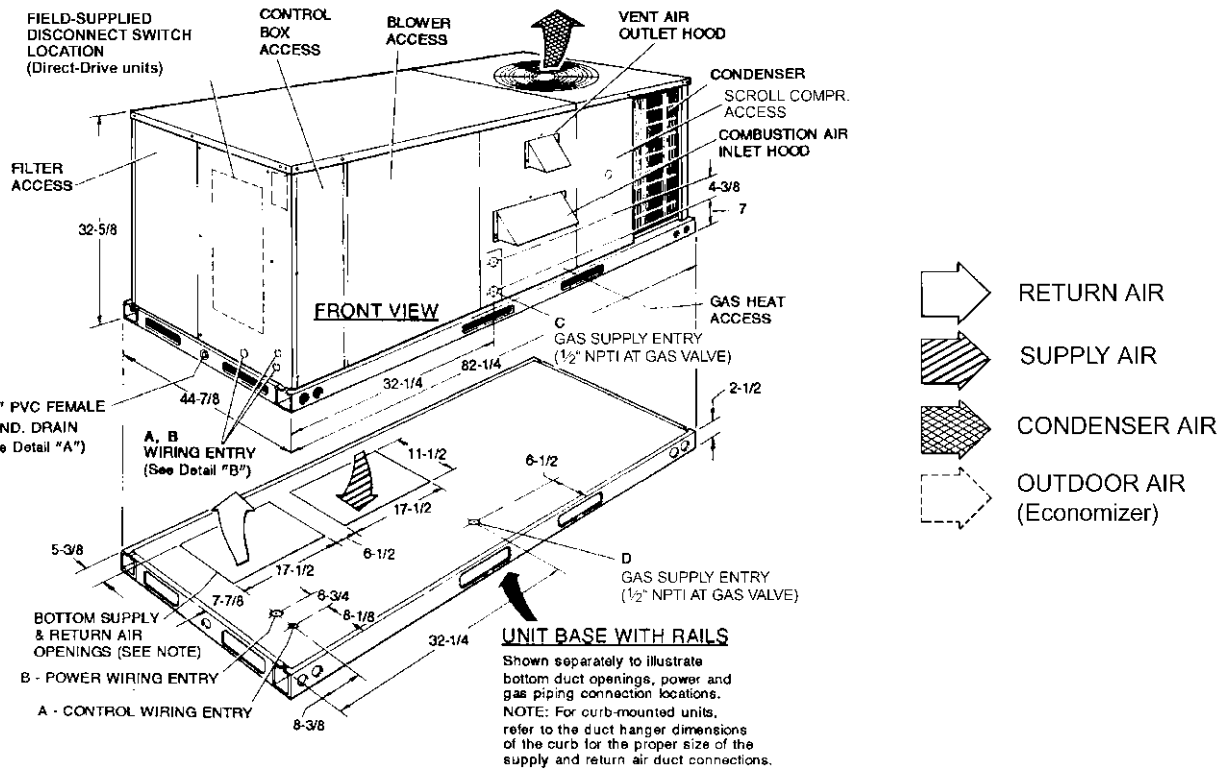

FIGURE 4: UNIT DIMENSIONS (3 - 6 TON COOLING/GAS HEAT) FRONT VIEW

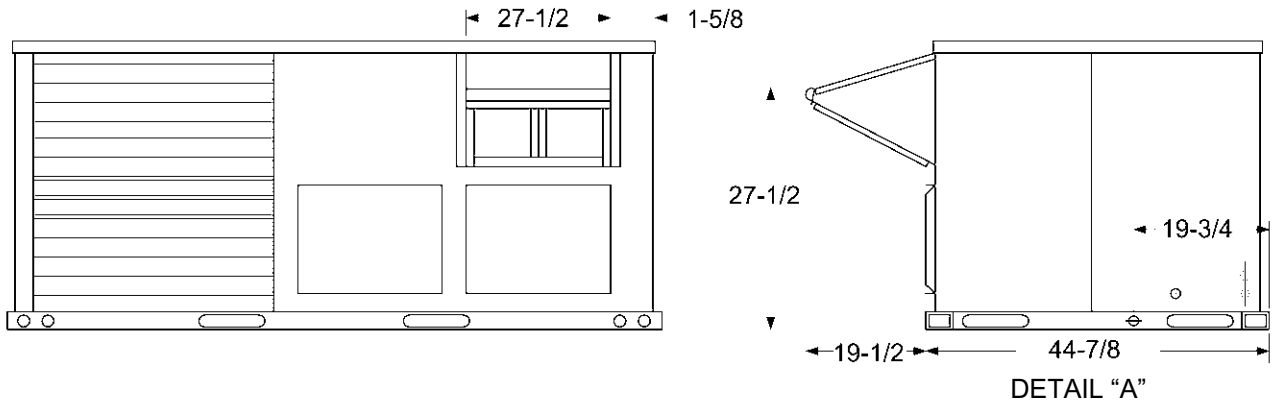

FIGURE 5: UNIT WITH ECONOMIZER RAINHOOD

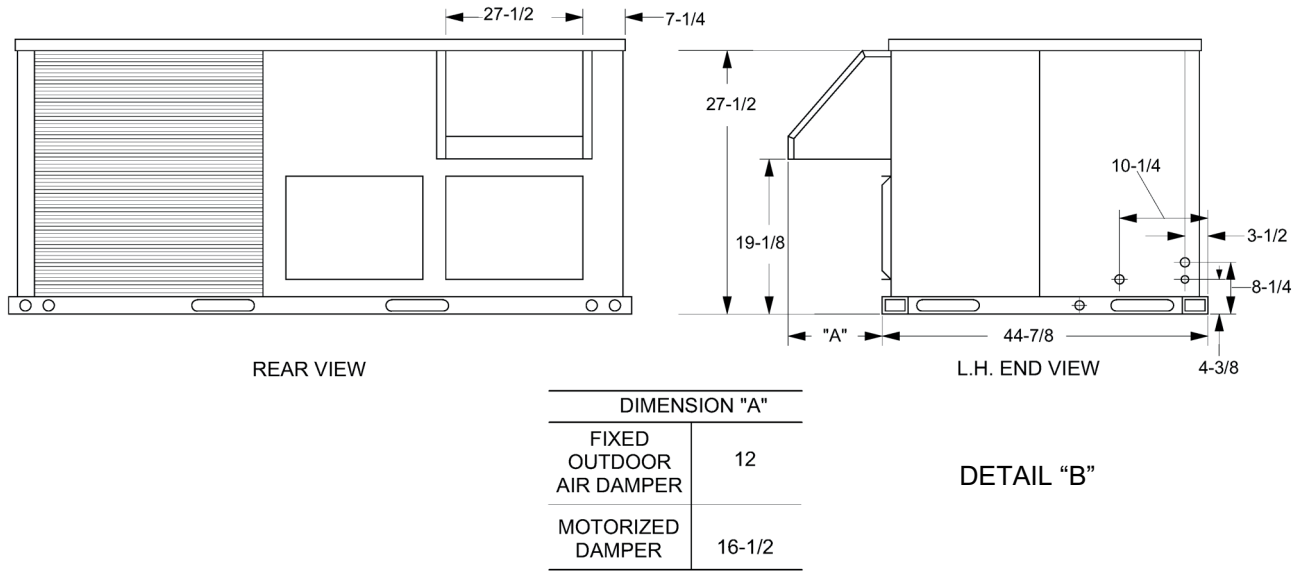

FIGURE 6: UNIT WITH FIXED OUTDOOR AIR/MOTORIZED DAMPER RAINHOOD

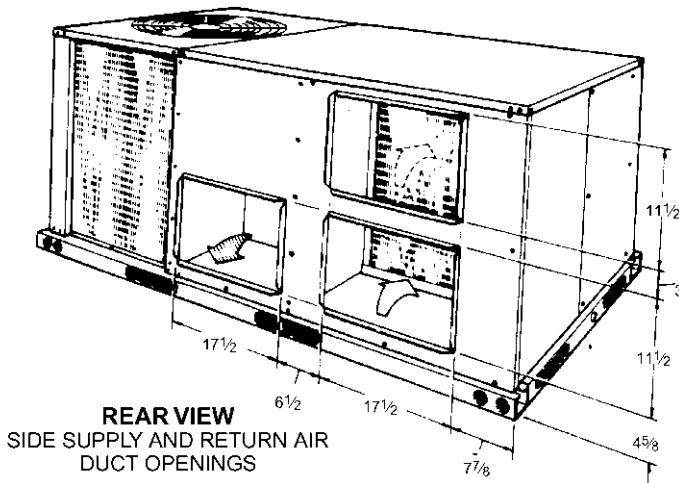

FIGURE 7: UNIT DIMENSIONS (REAR VIEW)

DUCT COVERS - Units are shipped with all air duct openings covered.

For side duct applications;

1. Remove and discard the supply and return air duct covers.
2. Connect ductwork to duct flanges on the rear of the unit.

For bottom duct applications;

1. Remove the side supply air duct cover to gain access to the bottom supply air knockout panel.
2. Remove and discard the bottom knockout panel.
3. Replace the side duct cover.
4. With filter section access panel removed from the unit, remove and discard the bottom return air knockout panel.
5. Replace the filter access panel.

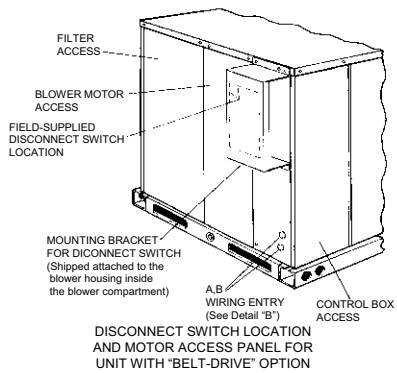

FIGURE 8: DISCONNECT/BLOWER ACCESS LOCATION

TABLE 28: MINIMUM CLEARANCES

LOCATION	CLEARANCE
Front	24" (Cooling/Electric Heat)
	32" (Gas Heat)
Back	12" (Less Economizer)
	36" (With Economizer or Fixed Air/Motorized Damper)
Left Side (Filter Access)	24" (Less Economizer)
	36" (With Economizer)
Right Side (Cond. Coil)	24"
Below Unit ¹	0"
Above Unit ²	72" (For Condenser Air Discharge)

1. Units may be installed on combustibile floors made from wood or class A, B, or C roof covering material.
2. Units must be installed outdoors. Overhanging structures or shrubs should not obstruct condenser air discharge outlet.

TABLE 27: UTILITIES ENTRY

HOLE	OPENING SIZE (DIA.)	USED FOR
A	7/8" KO ¹	Control Wiring ²
		Side Bottom
B	2" KO ¹	Power Wiring
		Side Bottom
C	1-5/8" KO	Gas Piping (Front)
D	1-1/2" KO	Gas Piping (Bottom)

1. Opening in the bottom to the unit can be located by the side in the insulation.
2. Do not remove the 2" knockout ring.

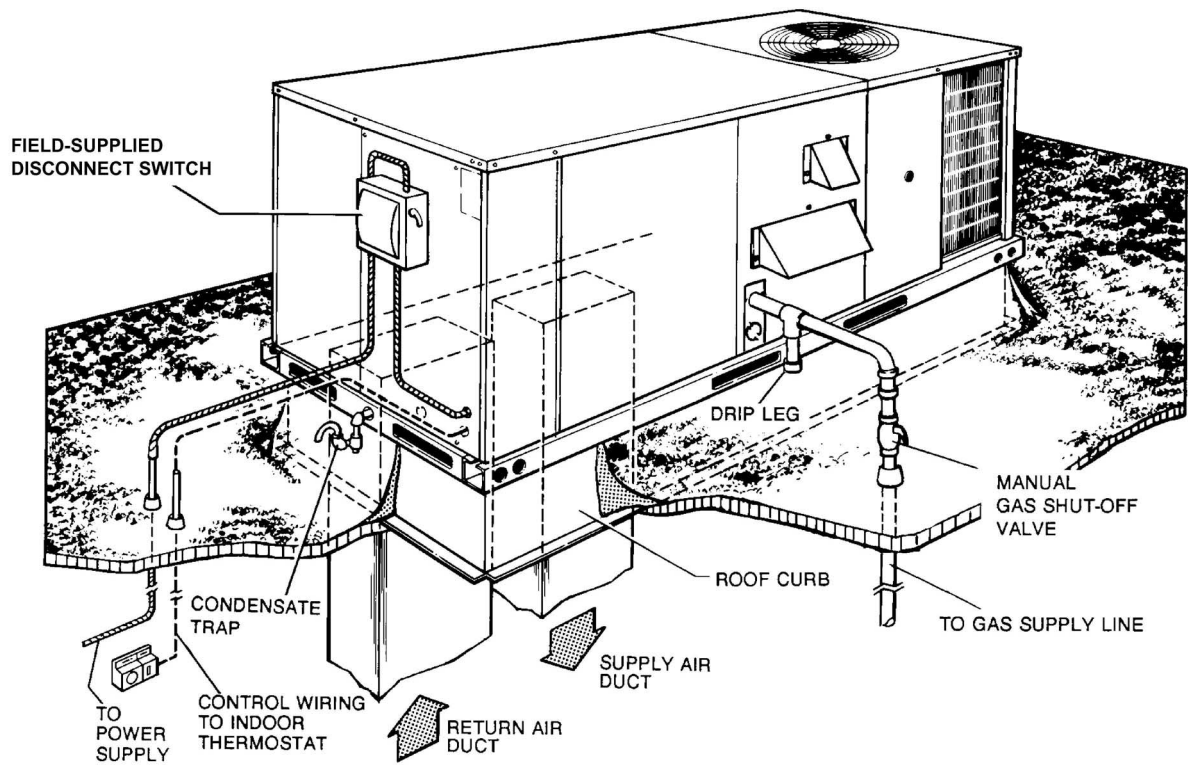
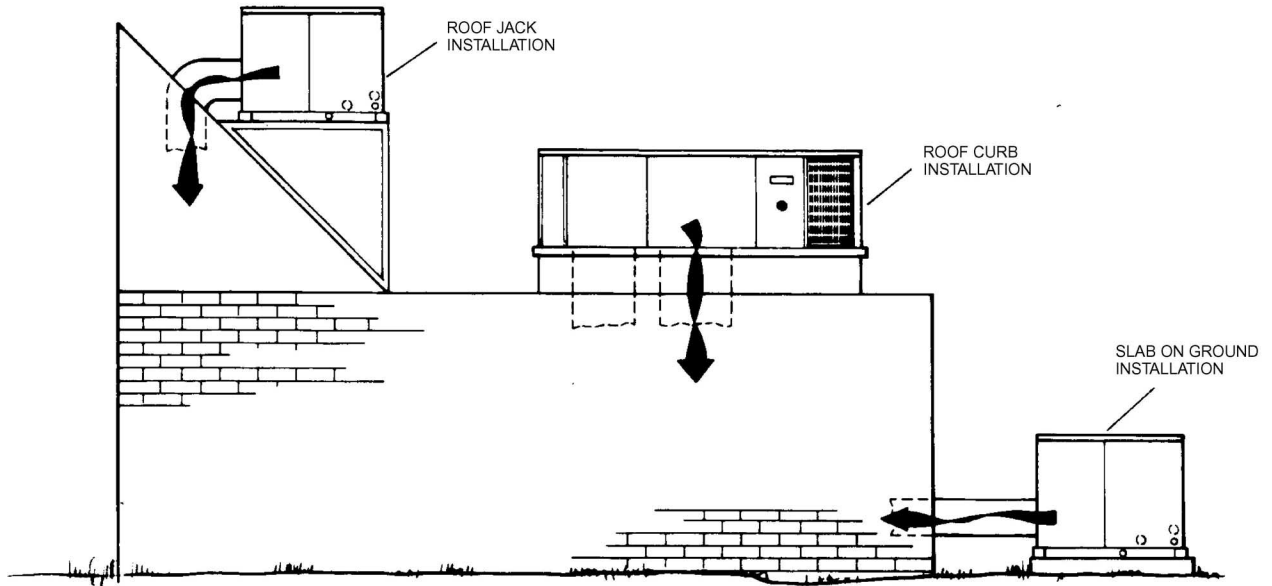

FIGURE 9: TYPICAL APPLICATIONS

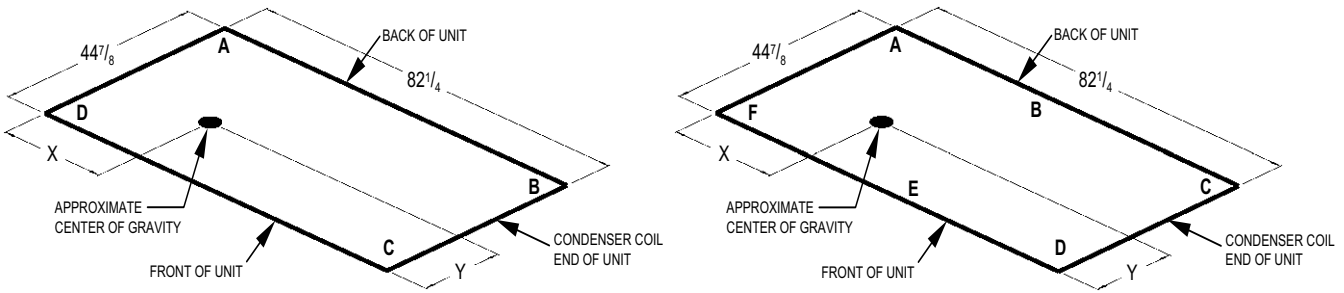

FIGURE 10: FOUR AND SIX POINT LOADING

TABLE 29: DM 4 POINT LOADS WEIGHT DISTRIBUTION

UNIT	TOTAL	A	B	C	D
DM036 Cooling/ Electric	565	125	123	157	160
DM036N04	625	140	133	172	180
DM036N08	635	140	138	177	180
DM048 Cooling/ Electric	615	137	135	170	173
DM048N06	675	152	145	185	193
DM048N10	685	152	150	190	193
DM060 Cooling/ Electric	640	143	140	177	180
DM060N08	700	158	150	192	200
DM060N10	710	158	155	197	200
DM072 Cooling/ Electric	720	164	189	196	171
DM072N08	775	179	201	209	186
DM072N10	785	179	206	214	186

TABLE 30: DM 6 POINT LOADS WEIGHT DISTRIBUTION

UNIT	TOTAL	A	B	C	D	E	F
DM036 Cooling/ Electric	565	84	83	82	104	105	107
DM036N04	625	93	92	91	115	117	118
DM036N08	635	94	93	92	117	119	120
DM048 Cooling/ Electric	615	91	90	89	113	115	116
DM048N06	675	100	99	98	124	126	128
DM048N10	685	102	100	99	126	128	129
DM060 Cooling/ Electric	640	95	94	93	118	119	121
DM060N08	700	104	103	101	129	131	132
DM060N10	710	105	104	103	131	133	134
DM072 Cooling/ Electric	720	107	117	129	134	122	111
DM072N08	775	115	126	139	144	131	120
DM072N10	785	117	128	141	146	133	121

TABLE 31: CENTER OF GRAVITY

DIMENSION	3 - 5 TON	6 TON
X	40-3/4"	44"
Y	19-3/4"	22"

TABLE 32: OPERATING WEIGHTS (LBS.)

MODEL SIZE		3 TON	4 TON	5 TON	6 TON	
BASIC UNIT	DM (Cooling Only)	565	615	640	720	
	DM (Gas/Electric)	N04	625	-	-	-
		N06	-	675	-	-
		N08	635	-	700	775
		N10	-	685	710	785
OPTIONS	Economizer	50				
	Motorized Damper	26				
	Electric Heater	5 - 7 kW	18			
		10 - 15 kW	23			
		20 - 30 kW	28			
ACCY.	Roof Curb	92				
	Barometric Relief / Fixed Air Damper	10				
	Belt-Drive Blower	5				

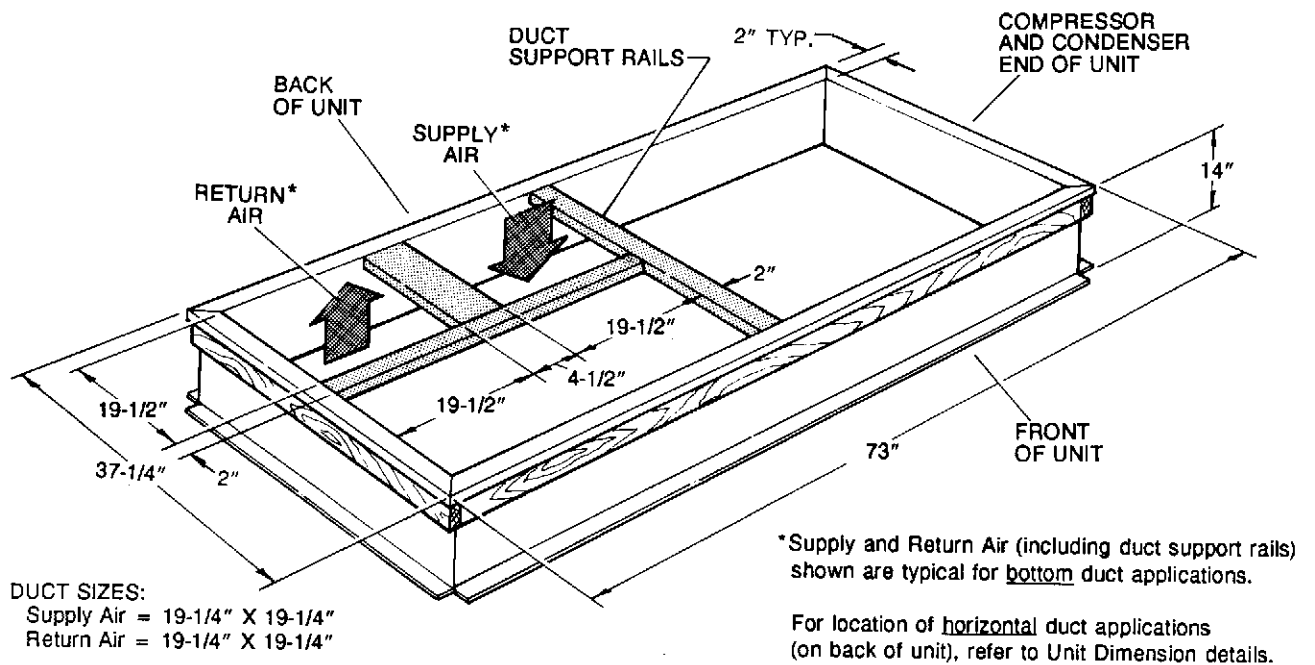

FIGURE 11: ROOF CURB DIMENSIONS

GUIDE SPECIFICATIONS

GENERAL

Units shall be manufactured by York International Unitary Products Group in an ISO 9001 certified facility.

York's Sunline 2000™ units are convertible single package-units. Although the units are primarily designed for curb mounting on a roof, they can also be slab-mounted at ground level or set on steel beams above a finished roof. Cooling only, cooling with gas heat and cooling with electric heat models are available with a wide variety of factory-mounted options and field-installed accessories to make them suitable for almost every application. All units are self-contained and assembled on full perimeter base rails with holes in the four corners for overhead rigging. Every unit is completely piped, wired, charged and tested at the factory to simplify the field installation and to provide years of dependable operation. All models (including those with an economizer) are suitable for either bottom or horizontal duct connections. Models with power exhaust are suitable for bottom duct connections only. For bottom duct, remove the sheet metal panels from the supply and return air openings through the base of the unit. For horizontal duct, remove the supply and return air panels on the rear of the unit.

All non-Scroll compressors include crankcase heaters and all compressors have internal pressure relief. Every refrigerant circuit includes a liquid line filter-drier, a discharge line high pressure switch and a suction line with a freeze-stat and low pressure/loss of charge switch. The unit control circuit includes a 75 VA transformer, a 24-volt circuit breaker and a relay board with a compressor lockout circuit, a terminal strip for thermostat wiring, plus an additional set of pin connectors to simplify the interface of additional field controls. All units have long lasting powder paint cabinets with 750 hour salt spray test approval under ASTMB117 procedures. All models are CSA listed. All models include a 1-year limited warranty on the complete unit. Compressors and electric heater elements carry a 5-year warranty. Aluminumized steel and Stainless steel tubular heat exchangers carry a 10-year warranty.

DESCRIPTION

Units shall be factory-assembled, single packaged, Electric Cooling/Gas Heat, Electric Cooling/Optional Electric Heat and designed for outdoor mounted installation.

The 3 thru 5 ton units shall have minimum SEER ratings of 10.0 and the 6 ton units shall have minimum EER ratings of 9.0. They shall have built-in field convertible duct connections for down discharge supply/return or horizontal discharge supply/return, and be available with factory installed options or field installed accessories. The units shall be factory wired, piped, charged with R-22 refrigerant and factory tested prior to shipment. All unit wiring shall be both numbered and color coded. All units the cooling performance shall be rated in accordance with DOE and ARI test procedures. Units shall be CSA listed, classified to ANSI Z21.47, UL 1995/CSA No. 236 standards.

UNIT CABINET

Unit cabinet shall be constructed of G90 galvanized steel, with exterior surfaces coated with a non-chalking, powdered paint finish, certified at 750 hours salt spray test per ASTMB117 standards. Indoor blower section shall be insulated with a minimum 1/2" thick insulation, coated on the air-side. Aluminum foil faced insulation shall be used in the furnace compartment and be fastened with ridged fasteners to prevent insulation from entering the air stream. Cabinet panels shall be "large" size, easily removable for servicing and maintenance. Full perimeter base rails shall be provided to assure reliable transit of equipment, overhead rigging and proper sealing on roof curb applications. Disposable 1" filters shall be furnished and be accessible through a removable access door, sealed airtight. Units filter track shall be designed to accommodate either 1" or 2" filters. Fan performance measuring ports shall be provided on the outside of the cabinet to allow accurate air measurements of evaporator fan performance without removing panels or creating air bypass of the coils. Condensate pan shall be internally sloped and conform to ASHRAE 62-89 self-draining standards. Condensate connection shall be a minimum of 3/4" I.D. female and be a ridged mount connection.

INDOOR (EVAPORATOR) FAN ASSEMBLY

The indoor fan shall be direct drive, multi-speed, or a factory installed belt drive assembly that includes an adjustable pitch motor pulley. Job site selected (B.H.P.) brake horsepower shall not exceed the motors nameplate horsepower rating, plus the service factor. Units shall be designed not to operate above service factor. Fan wheel shall be double-inlet type with forward-curved blades, dynamically balanced to operate smoothly throughout the entire range of operation. Airflow design shall be constant air volume. Bearings shall be sealed and permanently lubricated for longer life and no maintenance.

OUTDOOR (CONDENSER) FAN ASSEMBLY

The outdoor fan shall be of the direct-driven propeller type, discharge air vertically, have aluminum blades riveted to a corrosion resistant steel spider bracket and shall be dynamically balanced for smooth operation. The outdoor fan motor shall be totally enclosed with permanently lubricated bearings, internally protected against overload conditions and staged independently.

REFRIGERANT COMPONENTS

Compressor:

- a. Shall be internally protected with internal high-pressure relief and over temperature protection.
- b. Shall have internal spring isolation and sound muffling to minimize vibration and noise, and be externally isolated on a dedicated, independent mounting.

Coils:

- a. Evaporator and condenser coils shall have aluminum plate fins mechanically bonded to seamless

internally enhanced copper tubes with all joints brazed. Special Phenolic coating shall be available as a factory option.

- b. Evaporator and Condenser coils shall be of the direct expansion, draw-thru, design.

Refrigerant Circuit and Refrigerant Safety Components shall include:

- a. Independent fixed-orifice expansion devices.
- b. Filter drier/strainer to eliminate any moisture or foreign matter.
- c. Accessible service gage connections on both suction and liquid lines to charge, evacuate, and measure refrigerant pressure during any necessary servicing or troubleshooting without losing charge.
- d. The refrigeration system shall provide at least 15°F of sub-cooling at design conditions.

UNIT CONTROLS

- a. Unit shall be complete with self-contained low-voltage control circuit protected by a resettable circuit breaker on the 24-volt transformer side.
- b. Unit shall incorporate a lockout circuit which provides reset capability at the space thermostat or base unit, should any of the following standard safety devices trip and shut off compressor.
- c. Loss-of-charge/Low-pressure switch.
- d. High-pressure switch.
- e. Freeze-protection thermostat, evaporator coil.
- f. If any of the above safety devices trip, a LED (light-emitting diode) indicator shall flash a diagnostic code that indicates which safety switch has tripped.
- g. Unit shall incorporate "AUTO RESET" compressor over temperature, over current protection.
- h. Unit shall operate with conventional thermostat designs and have a low voltage terminal strip for easy hook-up.
- i. Unit control board shall have on-board diagnostics and fault code display.
- j. Standard controls shall include anti-short cycle and low voltage protection, and permit cooling operation down to 0°F.
- k. Control board shall monitor each refrigerant safety switch independently.
- l. Control board shall retain last 5 fault codes in non volatile memory, which will not be lost in the event of a power loss.

GAS HEATING SECTION

Shall be designed with induced draft combustion with post purge logic, energy saving direct spark ignition, and redun-

dant main gas valve. Venter wheel shall be constructed of stainless steel for corrosion resistance. The heat exchanger shall be of the tubular type, constructed of T1-40 aluminized steel for corrosion resistance and allowing minimum mixed air entering temperature of 25°F. Burners shall be of the inshot type, constructed of aluminum coated steel and contain air mixture adjustments. All gas piping shall enter the unit cabinet at a single location through either the side or curb, without any field modifications. An integrated control board shall provide timed control of evaporator fan functioning and burner ignition. Heating section shall be provided with the following minimum protection:

- a. Primary and auxiliary high-temperature limit switches.
- b. Induced draft motor speed sensor.
- c. Flame roll out switch (manual reset).
- d. Flame proving controls.

ELECTRIC HEATING SECTION

An electric heating section, with nickel chromium elements, shall be provided in a range of 5 thru 30 KW, offering two stages of capacity - 16 KW and above on 208/230 volt heaters and 20 KW and above on 460 and 575 volt heaters. The heating section shall have a primary limit control(s) and automatic reset to prevent the heating element system from operating at an excessive temperature. The heating section assembly shall slide out of the unit for easy maintenance and service. Units with Electric Heating shall be wired for a single point power supply with branch circuit fusing (where required).

UNIT OPERATING CHARACTERISTICS

- a. Unit shall be capable of starting and running at 125°F outdoor temperature, exceeding maximum load criteria of ARI Standard 210/240. The compressor, with standard controls, shall be capable of operation down to 0°F outdoor temperature. Unit shall be provided with fan time delay to prevent cold air delivery before heat exchanger warms up (Gas heat only).

ELECTRICAL REQUIREMENTS

All unit power wiring shall enter unit cabinet at a single factory provided location and be capable of side or bottom entry, to minimize roof penetrations and avoid unit field modifications. Separate side and bottom openings shall be provided for the control wiring.

STANDARD LIMITED WARRANTIES

- Compressor 5 Years
- Heat Exchanger 10 Years
- Electric Heat Element 5 Years
- Other Parts 1 Year

OPTIONAL OUTDOOR AIR (Shall be made available by either/or):

- **ELECTRONIC ENTHALPY AUTOMATIC ECONOMIZER**- Outdoor and return air dampers that are interlocked and positioned by a fully-modulating, spring return damper actuator. The maximum leakage rate for the outdoor air intake dampers shall not exceed 2% when dampers are fully closed and operating against a pressure differential of 0.5 IWG. A unit-mounted potentiometer shall be provided to adjust the outdoor and return air damper assembly to take in CFM of outdoor air to meet the minimum ventilation requirement of the conditioned space during normal operation. During economizer operation, a mixed-air temperature control shall modulate the outdoor and return air damper assembly to prevent the supply air temperature from dropping below 55°F. Changeover from compressor to economizer operation shall be provided by an integral electronic enthalpy control that feeds input into the basic module. The outdoor intake opening shall be covered with a rain hood that matches the exterior of the unit. Water eliminator/filters shall be provided. Simultaneous economizer/compressor operation is also possible. Dampers shall fully close on power loss.
- **MOTORIZED OUTDOOR AIR DAMPERS** - Outdoor air dampers are positioned by a 2-position, spring-return damper actuator. The maximum leakage rate for the outdoor air intake dampers shall not exceed 2% when dampers are fully closed and operating against a pressure differential of 0.5 IWG. A unit-mounted potentiometer shall be provided to adjust the outdoor damper assembly to take in the design CFM of outdoor air to meet the ventilation requirements of the conditioned space during normal operation. Whenever the indoor fan motor is energized, the dampers open up to one of two pre-selected positions - regardless of the outdoor air enthalpy. Dampers return to the fully closed position when the indoor fan motor is de-energized. Dampers shall fully close on power loss.

OTHER PRE-ENGINEERED ACCESSORIES AVAILABLE

- **ROOF CURB** - 14"and 8" high, full perimeter curb with wood nailer (shipped knocked-down).
- **BAROMETRIC RELIEF DAMPER** - Contains a rain hood, air inlet screen, exhaust damper and mounting hardware. Used to relieve internal air pressure through the unit.
- **PROPANE CONVERSION KIT** - Contains new orifices and gas valve parts to convert from natural to L.P. gas. One per unit required.
- **HIGH ALTITUDE - NATURAL GAS** - Contains orifices required for applications between 2000 and 6000 feet altitude.

- **HIGH ALTITUDE - PROPANE GAS** - Contains orifices required for applications between 2000 and 6000 feet altitude. Must be used with propane conversion kit.
- **LOW NOX** - Required to reduce the emission of nitrogen oxides below 40 nanograms per joule.
- **GAS PIPING** - Contains 1/2" pipe nipples, fittings and gas cock (including panel assess gaskets) required for bottom gas supply connection with external shut off.
- **POWER EXHAUST OPTION** - To work in conjunction with economizers.
- **ELECTRIC HEATERS**
- **ECONOMIZER/MOTORIZED DAMPER RAIN HOOD** - Contains all hood panels and the hardware for assembling.
- **MANUAL OUTDOOR AIR DAMPER**
- **COIL GUARD KIT** - Guard for cooling coil.
- **HAIL GUARD**
- **FLUE EXHAUST EXTENSION**

OTHER FACTORY INSTALLED OPTIONS

- **POWER EXHAUST OPTION** - To work in conjunction with economizers.
- **STAINLESS STEEL HEAT EXCHANGER**
- **TECHNICOAT PHENOLIC COATED CONDENSER AND EVAPORATOR COIL**
- **ELECTRONIC SINGLE ENTHALPY ECONOMIZER**
- **DIRTY FILTER SWITCH**
- **PHASE MONITOR**
- **COIL GUARD**
- **POWERED GFI CONVENIENCE OUTLET**
- **NON-POWERED GFI CONVENIENCE OUTLET**
- **BAS CONTROLS (CPC, JOHNSON, HONEYWELL, NOVAR)**
- **BAS READY ECONOMIZER (BELIMO ACTUATOR WITHOUT A CONTROLLER)**
- **HINGED FILTER DOOR ACCESS AND TOOLESS ACCESS PANELS**
- **2" PLEATED FILTERS**
- **DISCONNECT SWITCH**
- **SUPPLY AIR SMOKE DETECTOR**
- **RETURN AIR SMOKE DETECTOR**

Subject to change without notice. Printed in U.S.A.
Copyright © by Unitary Products 2003. All rights reserved.

036-21502-002-A-0303
Supersedes: 036-21502-001-A-0103

**Unitary
Products
Group**

**5005
York
Drive**

**Norman
OK
73069**