



Heating and Air Conditioning

TECHNICAL GUIDE

**R-410A
SPLIT-SYSTEM
AIR HANDLERS**

MILLENNIUM™

ND360, 480 & 600

**30 - 50 Ton
60 Hertz**

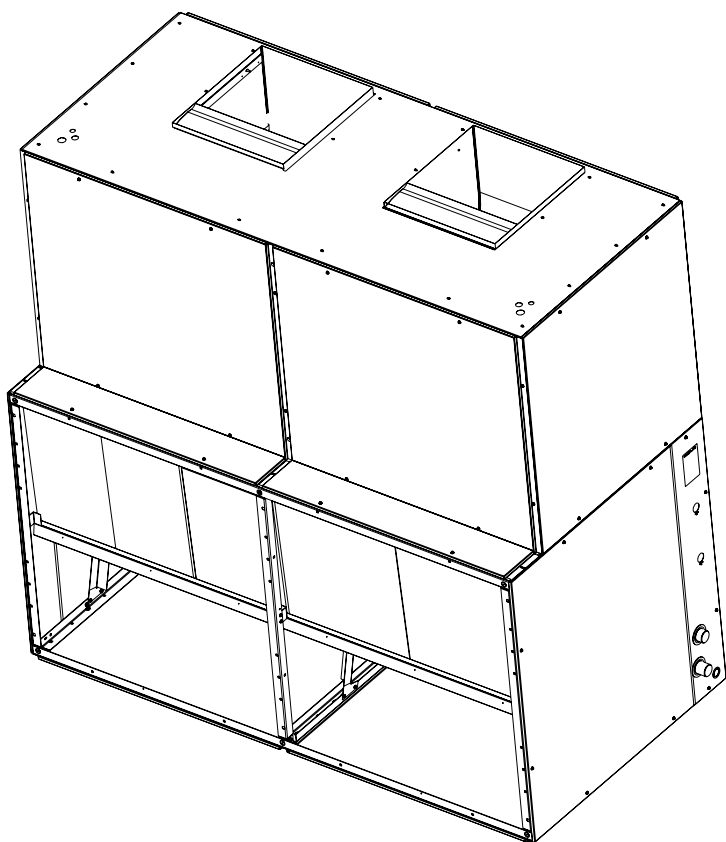

ND600 AIRHANDLER & M1CZ600 EVAPORATOR SECTION

Description

These air handling units are completely assembled units, including a well-insulated cabinet, a DX cooling coil with copper tubing, aluminum fins, expansion valve(s), distributor(s), 2" throwaway filters, a centrifugal blower, a blower motor, an adjustable belt drive, a blower motor contactor and a small holding charge of nitrogen.

Units are shipped in the vertical position ready for field installation, but can be easily converted to horizontal position.



ISO 9001
Certified Quality
Management System

Table of Contents

Description	1
Table of Contents	2
Nomenclature	3
Air Handling Unit Features and Benefits	4
Guide Specifications	5
Physical Data	7
Unit Limitations	8
Cooling and Heating Ratings	8
Capacity Performance	9
Air Handling Unit and Hot Water Coil Accessory Heating Capacity	15
Air Handling Unit and Steam Coil Accessory Heating Capacity	16
Fan Performance	17
Sound Performance	19
Electrical Data	20
Typical Wiring Diagrams	21
Weights And Dimensions	22
Unit Mounting	32
Typical Field Wiring Diagrams	36

Nomenclature

Configured Split Air Handler Model Number Nomenclature

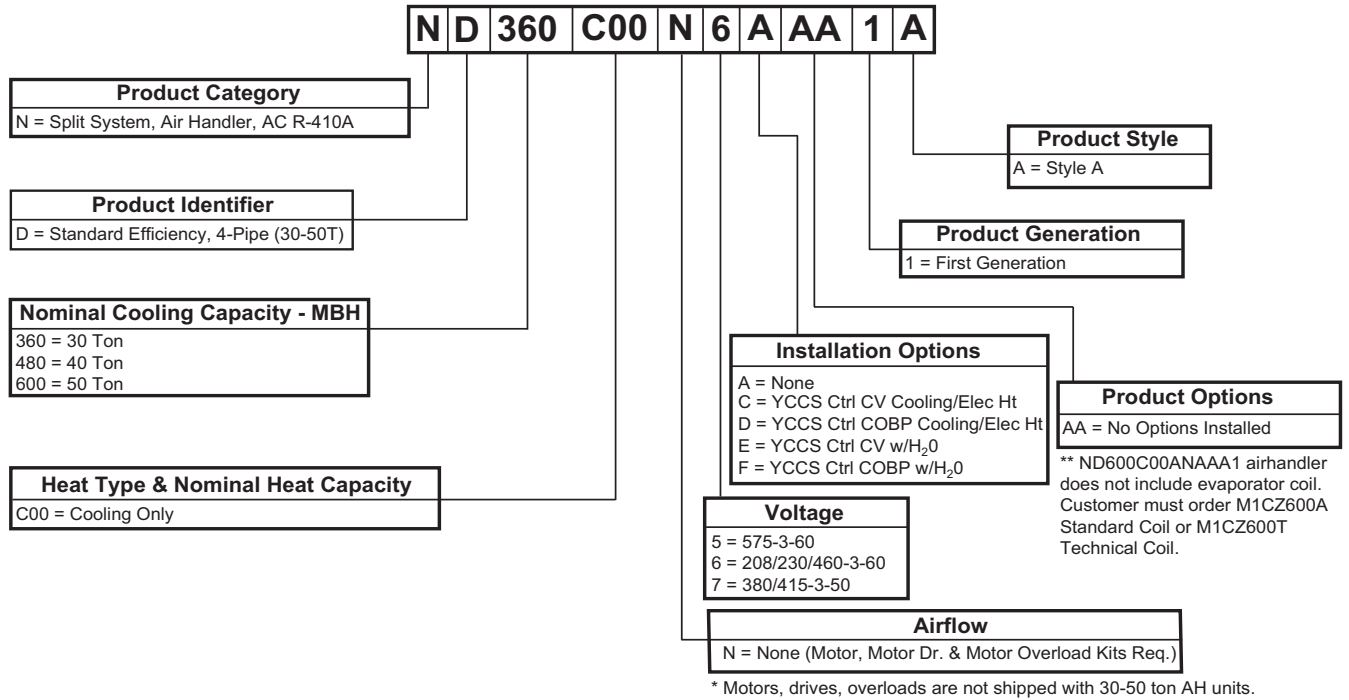

Air Handling Unit Features and Benefits

Features

These air handlers can be arranged for a variety of air discharge patterns in either the horizontal or vertical position. Refer to the unit installation instructions for other application possibilities.

Benefits

Air handling units are designed with two distinct modules to provide maximum application flexibility. ND360 and 480 Models are shipped as single packages with the blower module mounted on top of the coil module. The ND600 Blower Section and the M1CZ600 Evaporator Section are shipped separately and must be assembled on the job site. All blower modules can be repositioned in the field to meet a large number of vertical and horizontal applications.

The blower module includes the blower wheels and room for a field-mounted motor and drive. All models offer multiple motor horsepower and drive options to meet both standard and high static airflow requirements. The coil module includes direct expansion coils, 2 in. throwaway filters, liquid line solenoid valves for capacity reduction, thermal expansion valves, distributors and a condensate drain pan.

Every air handling coil is pressurized with air and leak tested under water. After the headers are brazed onto the coil and the coil is installed in the unit, the coil is pressurized with nitrogen for pressure testing and additional leak testing. After the coil is evacuated and dehydrated, it is pressurized with a holding charge of nitrogen for storage and/or shipping.

These air handlers, combined with condensing units, provide years of quiet, efficient and dependable operation. These units are manufactured under ISO 9001 Quality System Certification.

Unit Installation

Units may be bottom-supported or ceiling-suspended and can be arranged to meet almost any space or duct requirements. Each unit is available with a choice of blower motor horsepower, drive packages and other accessories to make them suitable for most applications.

Blower Motors: Different HP motors are available for each unit to meet almost any air delivery requirement. All motors are UL approved, have permanently lubricated ball bearings and are field-mounted within the insulated cabinet of the units to minimize the transmission of sound to the surrounding space.

Air Handling units are available in four pipe configurations from 30 to 50 tons. The dual circuit options provide a wide variety of application and unit matchup possibilities.

Starters and Heater Elements: These blower motors do not have inherent protection and require external motor overload protection. See details in Overload Elements Table.

NOTE: Power wiring for blower motors is field supplied.

Factory-Mounted Components

Part Load Operation: These air handlers have multiple DX (Direct Expansion) coils with pre-piped distributors,

expansion valves and solenoid valves. Field modifications are not required for part load operations. Capacity reduction not only provides economical operation, but also maintains stable temperature and humidity levels in the conditioned space.

BAS Control: York Commercial Comfort System (YCCS) provides split system integration for YCCS single zone, change-over bypass and VAV systems.

Easy Service: Serviceable expansion valves are provided on every unit. These valves are factory-installed to provide many years of trouble-free operation. If service is required, it is not necessary to unbrazed any joints. The expansion valves also include a tee fitting to allow easy installation of hot gas bypass if required.

Coil Protection: The indoor coils of these air handlers can be factory Technicoated to provide extended life to the indoor coil in standard applications and additional corrosion protection on those applications in sea coast or corrosive environments.

Blower Motors: Different HP motors are available for each unit to meet almost any air delivery requirement. 5 HP motors are inherently protected. 7.5 thru 15 HP motors require motor overload protection.

NOTE: Power wiring for blower motor is field supplied on all Unit Models.

Accessories

Base Sections (30 and 40 ton): Base sections can be used to elevate units above the floor. If desired, a moderate percentage of outdoor air may be introduced through these sections by cutting an access opening to accommodate the outdoor air duct connection. These bases include a durable finish to match the evaporator blower unit. The base may have to be insulated for certain applications.

Hot Water Coils: Drainable water coils are available for field installation between the blower and the coil modules of both horizontal and vertical units. Since their casings match the dimensions and the finish of the basic units, they become an integral part of the unit after installation. The coils slide out of their casings for easy installation. Hot water coils have copper tubes that have been mechanically expanded into aluminum fins. Both headers are located on the same end of the coil. Coils are leak-tested at 325 psig under water and dried before their connections are capped for storage and shipping.

Steam Coils (30 ton only): Steam coils are available for installation between the blower and coil modules of both horizontal and vertical units. Since the casing matches the dimensions and the finish of the basic unit, it becomes an integral part of the unit after installation. The coil slides out of the casings for easy installation and is pitched in the casings to facilitate condensate drainage. The coil has copper tubes that have been mechanically expanded into aluminum fins. Both headers are located on the same end of the coil. The coil is leak-tested at 325 psig and dried before the connections are capped for storage and shipping.

Guide Specifications

MILLENNIUM™

Split System Air-Cooled Air Handler Models: NC300 and ND360, 480 and 600

General

Units shall be manufactured by Johnson Controls, Unitary Products Group in an ISO 9001 certified facility. These factory-assembled units include a well-insulated cabinet, a DX cooling coil with copper tubes and aluminum fins, expansion valve(s), distributor(s), throwaway filters, a centrifugal blower, a blower motor, an adjustable belt drive, a blower motor contactor and a small holding charge of nitrogen. The units are shipped in the vertical position ready for field installation. The air handler units can be installed for horizontal operation by reversing the position of the solid bottom panel with the return air duct flange on the front of the unit. The products must be tested per ARI 340/360 and Underwriter Laboratories U.L. 1995 and carry both CSA and ARI certification.

Description

The NC/ND indoor units are completely piped and wired at the factory and are shipped ready for immediate installation. Only the interconnecting liquid and suction lines, control wiring, and the main power wiring are required to complete the installation. Every coil is dehydrated, evacuated, leak tested and pressure tested at 450 psig before being pressurized with a holding charge of nitrogen for shipment and/or storage.

To eliminate the costly cabinet deterioration problems usually associated with outdoor equipment, all sheet metal parts are constructed of commercial grade (G90) galvanized steel. After fabrication, each part is thoroughly cleaned to remove any grease or dirt from its surfaces. The parts that will be exposed to the weather are then coated with a powder paint to assure a quality finish for many years. This coating system has passed the 1000-hour, salt spray test per ASTM Standard B117.

Unit Cabinet

Cabinet shall be constructed of 18 gauge, zinc coated steel, finished with a powder paint process capable of withstanding a minimum of 1000 salt spray hours according to ASTM B117. Cabinet screws shall comply with the ASTM B117 salt spray test for a minimum of 1000 hours. Panels shall be removable for easy access to all internal components during maintenance and service. A filter rack shall be included to accommodate 1" or 2" filters. Cabinet shall feature a separate access panel for the controls so that unit airflow need not be disturbed during servicing. The NC300, ND360-480 units are shipped in the vertical position ready for field

installation. The blower module can be repositioned in the field for maximum flexibility. The ND600 product ships with a separate M1CZ600A evaporator coil and can be assembled in the vertical or horizontal position in the field.

Each unit shall have:

- a. A steel angle frame to provide the rigid support required for shipping, rigging and years of dependable operation.
- b. Exterior panels of 18 gauge steel, finished with baked enamel to provide a long-lasting quality appearance.
- c. Removable panels to provide easy access to the internal components for maintenance and service.
- d. A filter rack with 1" or 2" filters.

Indoor (Evaporator) Fan Assembly

Fan shall be a belt drive assembly and include an adjustable pitch motor pulley. Job site selected brake horsepower shall not exceed the motors nameplate horsepower rating plus the service factor. Units shall be designed to operate within the service factor. Fan wheel shall be double-inlet type with forward-curved blades, dynamically balanced to operate smoothly throughout the entire range of operation. Airflow design shall be constant air volume. Bearings shall be sealed and permanently lubricated for longer life and no maintenance. Blower motors and drive kits are ordered separately. Power wiring for blower motor is field supplied.

Refrigerant Components

Coils:

- a. Evaporator coils shall have aluminum plate fins mechanically bonded to seamless internally enhanced copper tubes with all joints brazed.
- b. Evaporator coil shall be of the direct expansion, draw through design.

Refrigerant Circuit and Refrigerant Safety Components:

- a. Include factory-mounted distributors, adjustable thermal expansion valves and solenoid valves for both capacity reduction and refrigerant pump out on start-up.
- b. Include factory installed auxiliary side connectors for the addition of field installed hot gas bypass.
- c. Shall include filter/strainer to eliminate any foreign matter.

Controls

Unit controls shall include 208/230/460 or 575 volt transformer, blower motor contactor and relay, as well as a low voltage terminal block. Unit wiring shall be color-coded for easy service and trouble shooting.

The Installer Shall:

Furnish condensing units in accordance with the performance schedules shown on the plans. Install each unit as shown on the plans in accordance with the manufacturer's recommendations and all applicable national and local codes.

Unit Operating Characteristics

Unit shall be capable of starting and running at 125° F outdoor temperature, exceeding maximum load criteria ARI Standard 360. The compressor, with standard controls, shall be capable of operation down to 40° F outdoor temperature.

Electrical Requirements

All unit wiring shall enter unit cabinet at a single factory provided location to minimize cabinet penetrations and avoid unit field modifications.

Each Unit Shall Include The Following Accessories:

- "Suspension kit
- "Return air grille
- "Hot water coil
- "Steam coil
- "Decorative base
- Metal skid
- "Wood skid

Physical Data

ND360, 480 & 600 Physical Data

Component	Models		
	ND360	ND480	ND600 ¹
Nominal Tonnage	30	40	50
DIMENSIONS (inches)			
Length	100.1	103.1	105.1
Width	38.1	45.4	53.7
Height	74.6	89.4	99.0
WEIGHTS² (lb)			
Unit Shipping	1122	1246	1684
Unit Operating With			
5 hp Motor and Drive	1184	---	---
7.5 hp Motor and Drive	1208	1348	1742
10 hp Motor and Drive	1224	1364	1859
INDOOR BLOWER			
Diameter x Width	18 X 18	18 X 18	20 x 18
Qty.	2	2	2
INDOOR COIL			
Face area (Sq. Ft.)	25.8	33.3	41.3
Rows	4	4	4
Fins per inch	16	16	16
Tube diameter	3/8	3/8	3/8
Circuitry Type	Interlaced	Interlaced	Interlaced
Refrigerant Control	TEV	TEV	TEV
SYSTEM DATA			
No. Refrigeration Circuits	2	2	2
Suction Line OD (in.)	1 1/8	1 3/8	2 1/8
Liquid Line OD (in.)	7/8	7/8	7/8
FILTERS			
Size and Quantity Per Model (In.)	16 x 20 x 2	---	6
	20 x 20 x 2	---	3
	20 x 22 x 2	---	---
	16 x 25 x 2	---	6
	20 x 25 x 2	10	6
	25 x 25 x 2	---	6
Face area (Sq. Ft.)	34.7	42.6	53.1
ACCESSORY			
HOT WATER COIL DATA			
Face area (Sq. Ft.)	21.2	27.2	27.2
Rows	2	2	2
Fins per inch	12	12	8
Tube diameter (Copper) OD (In.)	1/2	1/2	1/2
Connections (Supply and Return) OD (In.)	1 3/8	1 5/8	1 5/8
Weight (lb)	150	190	190
STEAM COIL DATA			
Face area (Sq. Ft.)	18.2	---	---
Rows	1	---	---
Fins per inch	8	---	---
Tube diameter (Copper) (In.)	1	---	---
Connection, (NPTE) (In.)			
Inlet	2	---	---
Outlet	1-1/2	---	---
Weight (lb)	160	---	---

¹ ND600 and M1CZ600A Combined

² Motor, Motor Drive and Motor Overload Kits must be ordered separately, The Motor, Motor Drive and Overload Kits are to be field installed.

Unit Limitations

Air Handling Unit Limitations

Model	Power Supply Voltage	Voltage Variation		Supply Air Range CFM		Entering Air Temperature Degrees °F			
		Min.	Max.	Min.	Max.	Cooling DB/WB		Heating DB ¹	
						Min.	Max.	Min.	Max.
ND360	208/230-3-60	187	253	10,000	14,000	65/57	95/72	40	77
	460-3-60	414	506	10,000	14,000	65/57	95/72	40	77
	575-3-60	540	630	10,000	14,000	65/57	95/72	40	77
ND480	208/230-3-60	187	253	12,800	19,200	65/57	95/72	40	77
	460-3-60	414	506	12,800	19,200	65/57	95/72	40	77
	575-3-60	540	630	12,800	19,200	65/57	95/72	40	77
ND600	208/230-3-60	187	253	16,000	24,000	65/57	95/72	40	77
	460-3-60	414	506	16,000	24,000	65/57	95/72	40	77
	575-3-60	540	630	16,000	24,000	65/57	95/72	40	77

¹ Heating Min/Max temperatures apply to steam and hot water coils. NOTE: Do not apply steam to hot water coils.

Cooling and Heating Ratings

Cooling Ratings

Outdoor Unit	Condensing Unit Only			Indoor Unit	System Cooling Capacity ¹			Rated Airflow (CFM)
	Gross Capacity ² (MBH)	kW	EER		Gross Capacity ³ (MBH)	EER	IEER	
YD360	333	29.9	11.1	ND360	375	10.0	11.1	12,000
YD480	469	37.4	12.5	ND480	500	10.0	10.8	16,000
YD600	576	50.0	11.5	ND600	620	10.0	10.4	17,500

¹ Certified in accordance with the Unitary Large Equipment certification program, which is based on ARI Standard 340/360.

² Condensing unit only ratings are at 45 F SST and 95 F entering-air temperature.

³ Deduct 1 MBH when a unit operates at 208 volts.

EER = Energy Efficiency Ratio at full load - the cooling capacity in Btu's per hour (Btuh) divided by the power input in watts, expressed in Btuh per watt (Btuh/watt).

EER; condensing unit only ratings based on 45° F SST and 95°F entering outdoor air temperature.

IEER - A single number cooling part-load efficiency figure that is calculated based on equipment stages and EER at these capacity stages (ANSI/ARI STD 340/360 - 2007)

LEGEND

EER = Energy Efficiency Ratio

SST = Saturated Suction Temperature

ARI = Air Conditioning and Refrigeration Institute

IEER = Integrated Energy Efficiency Ratio

Capacity Performance

Condenser and Air Handling Cooling Capacities

YD360/ND360

Air on Evaporator Coil		Temperature of Air on Condenser Coil																	
CFM	WB (°F)	Total Capacity ¹ (MBh)	Total Input (kW) ²	Sensible Capacity (MBh)								Total Capacity ¹ (MBh)	Total Input (kW) ²	Sensible Capacity (MBh)					
				Return Dry Bulb (°F)										Return Dry Bulb (°F)					
				90	85	80	75	70	65	90	85			80	75	70	65		
		75°F								85°F									
9000	77	440.3	26.1	221.9	185.2	148.6	-	-	-	424.8	28.5	215.2	179.0	142.8	-	-			
	72	411.6	25.5	272.6	235.9	199.2	162.5	-	-	396.5	28.0	265.3	229.1	192.9	156.7	-			
	67	382.9	24.9	323.2	286.6	249.9	213.2	176.5	-	368.3	27.5	315.5	279.3	243.1	206.8	170.6			
	62	318.5	24.4	318.5	301.8	265.1	228.4	191.8	155.1	311.2	26.9	311.2	300.3	264.1	227.9	191.7	155.5		
	57	347.4	24.2	347.4	347.4	312.7	276.0	239.3	202.7	335.5	26.8	335.5	335.5	304.9	268.7	232.5	196.3		
10500	77	454.2	26.4	247.9	202.9	157.8	-	-	-	437.9	28.7	236.3	194.0	151.8	-	-			
	72	424.6	25.8	301.8	256.7	211.7	166.6	-	-	408.7	28.2	289.6	247.3	205.1	162.8	-			
	67	394.9	25.2	355.6	310.6	265.5	220.5	175.4	-	379.6	27.7	342.9	300.6	258.4	216.1	173.9			
	62	328.6	24.6	328.6	320.2	281.7	238.2	191.6	146.6	320.8	27.2	320.8	315.4	280.7	238.5	196.2	154.0		
	57	358.3	24.4	358.3	358.3	332.3	290.0	242.2	197.1	345.9	27.0	345.9	345.9	324.2	281.9	239.6	197.4		
12000	77	468.1	26.7	274.0	220.6	167.1	-	-	-	451.0	29.0	257.4	209.1	160.8	-	-			
	72	437.5	26.1	331.0	277.6	224.1	170.7	-	-	421.0	28.5	313.9	265.5	217.2	168.9	-			
	67	407.0	25.4	388.0	334.6	281.1	227.7	174.3	-	391.0	27.9	370.3	322.0	273.7	225.4	177.1			
	62	338.6	24.9	338.6	338.6	298.3	248.0	191.5	138.1	330.4	27.4	330.4	330.4	297.4	249.1	200.8	152.4		
	57	369.3	24.7	369.3	369.3	351.8	303.9	245.0	191.6	356.2	27.2	356.2	356.2	343.4	295.1	246.7	198.4		
13500	72	448.4	26.2	338.1	287.0	235.8	184.6	-	-	430.4	28.6	326.0	277.3	228.5	179.8	-			
	67	417.1	25.5	399.7	346.9	295.7	244.5	193.3	-	399.7	28.0	385.4	336.7	288.0	239.2	190.5			
	62	347.0	25.0	347.0	347.0	313.7	264.1	211.4	160.2	337.8	27.5	337.8	337.8	312.9	264.2	215.4	166.7		
	57	378.4	24.8	378.4	378.4	369.7	321.3	267.3	216.1	364.1	27.3	364.1	364.1	357.7	309.0	260.3	211.5		
	15000	72	459.3	26.3	345.3	296.3	247.4	198.4	-	-	439.7	28.7	338.2	289.0	239.9	190.7	-		
67		427.2	25.7	411.4	359.3	310.3	261.3	212.3	-	408.4	28.1	400.5	351.4	302.2	253.1	203.9			
62		355.5	25.1	355.5	355.5	329.2	280.2	231.2	182.3	345.2	27.6	345.2	345.2	328.4	279.3	230.1	181.0		
57		387.6	24.9	387.6	387.6	387.6	338.6	289.6	240.7	372.1	27.4	372.1	372.1	372.1	322.9	273.8	224.7		
		95°F								105°F									
9000	77	409.2	30.9	208.5	172.7	137.0	-	-	-	388.6	34.2	199.2	164.5	129.8	-	-			
	72	381.4	30.4	258.1	222.4	186.6	150.9	-	-	362.5	33.7	248.3	213.6	178.9	144.2	-			
	67	353.7	30.0	307.7	272.0	236.2	200.5	164.8	-	336.3	33.2	297.4	262.7	228.0	193.3	158.6			
	62	303.9	29.5	303.9	298.8	263.1	227.3	191.6	155.8	295.7	32.8	295.7	293.1	262.5	227.8	193.1	158.4		
	57	323.6	29.4	323.6	323.6	297.2	261.4	225.7	189.9	309.1	32.7	309.1	309.1	286.3	251.6	216.9	182.2		
10500	77	421.5	31.1	224.6	185.1	145.7	-	-	-	400.6	34.3	223.8	179.3	138.3	-	-			
	72	392.9	30.6	277.4	237.9	198.5	159.0	-	-	373.6	33.9	272.7	231.7	190.7	149.6	-			
	67	364.3	30.2	330.2	290.7	251.2	211.8	172.3	-	346.6	33.4	321.6	284.0	243.0	202.0	160.9			
	62	313.1	29.7	313.1	310.6	279.8	238.8	200.8	161.3	304.8	33.0	304.8	303.5	279.8	238.0	197.8	156.8		
	57	333.4	29.6	333.4	333.4	316.1	273.8	237.1	197.6	318.6	32.9	318.6	318.6	305.2	262.8	223.1	182.1		
12000	77	433.9	31.3	240.8	197.6	154.4	-	-	-	412.5	34.5	248.5	194.2	146.9	-	-			
	72	404.4	30.9	296.7	253.5	210.3	167.1	-	-	384.7	34.0	297.2	249.8	202.4	155.1	-			
	67	375.0	30.4	352.7	309.5	266.3	223.0	179.8	-	357.0	33.6	345.8	305.4	258.0	210.7	163.3			
	62	322.3	29.9	322.3	322.3	296.5	250.2	210.1	166.8	313.9	33.1	313.9	313.9	297.2	248.3	202.4	155.1		
	57	343.2	29.8	343.2	343.2	334.9	286.2	248.5	205.3	328.1	33.1	328.1	328.1	324.0	273.9	229.3	181.9		
13500	72	412.3	31.0	313.9	267.6	221.3	175.1	-	-	384.1	34.2	311.6	263.0	214.5	165.9	-			
	67	382.3	30.5	371.2	326.5	280.2	234.0	187.7	-	356.4	33.8	350.8	319.0	273.4	224.8	176.2			
	62	328.6	30.0	328.6	328.6	312.1	264.2	219.5	173.3	313.2	33.3	313.2	313.2	303.0	253.7	205.9	157.3		
	57	349.9	29.9	349.9	349.9	345.7	296.7	253.2	206.9	327.6	33.3	327.6	327.6	325.5	275.5	228.4	179.8		

YD360/ND360 (Continued)

Air on Evaporator Coil		Temperature of Air on Condenser Coil															
CFM	WB (°F)	Total Capacity ¹ (MBh)	Total Input (kW) ²	Sensible Capacity (MBh)						Total Capacity ¹ (MBh)	Total Input (kW) ²	Sensible Capacity (MBh)					
				Return Dry Bulb (°F)								Return Dry Bulb (°F)					
				90	85	80	75	70	65			90	85	80	75	70	65
		115°F						125°F									
15000	72	420.2	31.0	331.0	281.7	232.4	183.1	-	-	383.5	34.4	326.1	276.3	226.5	176.7	-	-
	67	389.7	30.6	389.7	343.5	294.2	244.9	195.6	-	355.8	34.0	355.8	332.7	288.7	239.0	189.2	-
	62	334.9	30.1	334.9	334.9	327.6	278.3	229.0	179.7	312.5	33.5	312.5	312.5	308.9	259.1	209.3	159.5
	57	356.6	29.9	356.6	356.6	356.6	307.3	257.9	208.6	327.0	33.5	327.0	327.0	327.0	277.2	227.4	177.6
9000	77	368.1	37.4	189.9	156.2	122.6	-	-	-	347.5	40.7	180.6	148.0	115.4	-	-	-
	72	343.5	37.0	238.5	204.8	171.2	137.5	-	-	324.5	40.2	228.6	196.0	163.4	130.8	-	-
	67	318.9	36.5	287.0	253.4	219.7	186.1	152.4	-	301.5	39.7	276.7	244.1	211.5	178.9	146.3	-
	62	287.4	36.1	287.4	287.4	262.0	228.3	194.7	161.0	279.1	39.5	279.1	279.1	261.4	228.8	196.2	163.6
57	294.6	36.1	294.6	294.6	275.4	241.8	208.1	174.5	280.1	39.5	280.1	280.1	264.5	231.9	199.3	166.7	
10500	77	379.6	37.5	223.1	173.6	131.0	-	-	-	358.7	40.7	222.3	167.8	123.6	-	-	-
	72	354.3	37.1	268.0	225.4	182.9	140.3	-	-	335.0	40.3	263.3	219.2	175.1	131.0	-	-
	67	328.9	36.6	313.0	277.3	234.8	192.2	149.6	-	311.2	39.8	304.4	270.6	226.5	182.4	138.3	-
	62	296.4	36.3	296.4	296.4	279.9	237.3	194.7	152.2	288.1	39.5	288.1	288.1	280.0	236.6	191.7	147.6
57	303.9	36.2	303.9	303.9	294.3	251.7	209.1	166.5	289.1	39.6	289.1	289.1	283.4	240.6	195.1	151.0	
12000	77	391.2	37.6	256.2	190.9	139.4	-	-	-	369.9	40.8	264.0	187.5	131.9	-	-	-
	72	365.1	37.2	297.6	246.1	194.6	143.1	-	-	345.4	40.3	298.0	242.4	186.7	131.1	-	-
	67	338.9	36.7	338.9	301.3	249.8	198.3	146.8	-	320.9	39.9	320.9	297.2	241.6	185.9	130.3	-
	62	305.5	36.4	305.5	305.5	297.8	246.3	194.8	143.3	297.1	39.6	297.1	297.1	244.4	187.2	131.6	-
57	313.1	36.4	313.1	313.1	313.1	261.6	210.1	158.6	298.1	39.7	298.1	298.1	298.1	249.3	190.9	135.3	
13500	72	355.9	37.5	309.4	258.5	207.6	156.7	-	-	327.7	40.8	307.1	253.9	200.8	147.6	-	-
	67	330.4	37.0	330.4	311.6	266.5	215.7	164.8	-	304.5	40.3	304.5	304.2	259.7	206.5	153.3	-
	62	297.8	36.7	297.8	297.8	294.0	243.1	192.2	141.4	282.4	40.0	282.4	282.4	282.4	232.5	178.6	125.4
	57	305.2	36.7	305.2	305.2	305.2	254.4	203.5	152.6	282.9	40.1	282.9	282.9	282.9	233.2	178.6	125.5
15000	72	346.7	37.8	321.1	270.9	220.7	170.4	-	-	310.0	41.2	310.0	265.5	214.8	164.1	-	-
	67	321.9	37.3	321.9	321.9	283.3	233.0	182.8	-	288.0	40.7	288.0	288.0	277.8	227.1	176.4	-
	62	290.1	37.0	290.1	290.1	290.1	239.9	189.6	139.4	267.7	40.4	267.7	267.7	267.7	220.7	170.0	119.3
	57	297.4	37.0	297.4	297.4	297.4	247.1	196.9	146.7	267.8	40.5	267.8	267.8	267.8	217.1	166.4	115.7

¹ These capacities are gross ratings. For net capacity, deduct supply air blower motor, MBh. Example: Refer to the appropriate Blower Performance Table for the BHP of the supply air blower motor, MBh = 3.415 x kW and kW = BHP x 0.746 ÷ nameplate rated motor efficiency.

² These ratings include the condenser fan motors and the compressor motors but not the supply air blower motor.

YD480/ND480

Air on Evaporator Coil		Temperature of Air on Condenser Coil															
CFM	WB (°F)	Total Capacity ¹ (MBh)	Total Input (kW) ²	Sensible Capacity (MBh)						Total Capacity ¹ (MBh)	Total Input (kW) ²	Sensible Capacity (MBh)					
				Return Dry Bulb (°F)								Return Dry Bulb (°F)					
				90	85	80	75	70	65			90	85	80	75	70	65
		75°F							85°F								
12000	77	579.6	32.8	292.9	247.9	202.9	-	-	-	530.5	35.1	268.7	224.3	179.9	-	-	-
	72	530.4	31.6	355.0	310.0	265.0	220.0	-	-	496.5	34.4	333.0	288.6	244.2	199.8	-	-
	67	481.2	30.3	417.1	372.1	327.1	282.2	237.2	-	462.6	33.7	397.3	352.9	308.5	264.1	219.7	-
	62	451.0	30.3	455.0	418.2	373.2	328.2	283.2	238.2	429.4	33.2	429.4	389.1	344.7	300.3	255.9	211.5
	57	448.9	29.6	448.9	448.9	437.7	392.7	347.7	302.7	421.3	33.0	421.3	421.3	395.3	351.0	306.6	262.2
14000	77	600.7	32.8	308.8	259.6	210.4	-	-	-	556.3	35.3	292.2	242.4	192.5	-	-	-
	72	549.4	31.5	372.5	323.3	274.1	224.9	-	-	520.6	34.6	361.0	311.2	261.3	211.4	-	-
	67	498.0	30.3	436.1	386.9	337.7	288.5	239.3	-	485.0	34.0	429.8	380.0	330.1	280.2	230.3	-
	62	466.9	30.3	468.9	435.1	385.9	337.8	287.4	238.2	450.2	33.4	450.2	418.7	368.8	318.9	269.0	219.1
	57	464.9	29.5	464.9	464.9	453.3	406.6	354.9	305.7	441.7	33.2	441.7	441.7	423.0	373.1	323.2	273.3
16000	77	621.8	32.8	324.8	271.4	217.9	-	-	-	582.0	35.6	315.8	260.4	205.1	-	-	-
	72	568.3	31.5	390.0	336.6	283.1	229.7	-	-	544.7	34.9	389.1	333.7	278.4	223.0	-	-
	67	514.9	30.3	455.2	401.7	348.3	294.9	241.4	-	507.4	34.2	462.4	407.0	351.6	296.3	240.9	-
	62	482.8	30.2	482.8	452.0	398.5	347.3	291.7	238.2	471.1	33.6	471.1	448.2	392.9	337.5	282.1	226.7
	57	481.0	29.5	481.0	481.0	468.9	420.5	362.1	308.6	462.2	33.5	462.2	462.2	450.6	395.2	339.9	284.5
18000	72	583.2	32.0	421.4	367.3	313.2	259.1	-	-	554.4	35.0	419.5	362.4	305.3	248.3	-	-
	67	528.6	30.8	498.7	439.6	385.5	331.4	277.3	-	516.5	34.4	493.9	442.9	385.8	328.7	271.6	-
	62	495.6	30.7	495.6	480.2	440.9	387.9	332.7	278.6	479.4	33.8	479.4	468.0	431.0	373.9	316.8	259.7
	57	493.6	30.0	493.6	493.6	487.6	435.9	379.4	325.3	470.4	33.6	470.4	470.4	464.6	407.5	350.4	293.3
	72	598.1	32.5	452.8	398.0	343.3	288.5	-	-	564.1	35.2	450.0	391.2	332.3	273.5	-	-
20000	67	542.3	31.3	542.3	477.4	422.6	367.9	313.1	-	525.5	34.5	525.5	478.7	419.9	361.0	302.2	-
	62	508.4	31.2	508.4	508.4	483.2	428.5	373.7	318.9	487.8	33.9	487.8	487.8	469.1	410.3	351.4	292.6
	57	506.2	30.5	506.2	506.2	451.4	396.7	341.9	-	478.6	33.8	478.6	478.6	478.6	419.8	361.0	302.1
			95°F							105°F							
	12000	77	481.4	37.4	244.5	200.7	156.9	-	-	-	462.2	41.8	256.0	212.6	169.1	-	-
72		462.7	37.3	311.0	267.2	223.4	179.6	-	-	446.3	41.6	315.8	272.4	229.0	185.5	-	-
67		443.9	37.1	377.5	333.7	289.9	246.1	202.3	-	430.4	41.4	375.6	332.2	288.8	245.4	201.9	-
62		407.8	36.1	403.8	360.0	316.2	272.4	228.6	184.8	405.5	40.9	403.5	363.1	319.7	276.2	232.8	189.4
57		393.7	36.5	393.7	393.7	353.0	309.2	265.4	221.6	382.2	41.0	382.2	382.2	345.7	302.2	258.8	215.4
14000	77	511.8	37.9	275.6	225.1	174.5	-	-	-	487.2	42.1	293.1	237.7	185.2	-	-	-
	72	491.9	37.7	349.6	299.0	248.5	197.9	-	-	470.4	41.8	355.9	303.4	250.8	198.3	-	-
	67	472.0	37.6	423.5	373.0	322.4	271.9	221.3	-	453.7	41.6	418.7	369.0	316.5	264.0	211.5	-
	62	433.6	36.5	431.5	402.2	351.7	300.0	250.6	200.0	427.3	41.1	426.3	402.4	350.3	297.2	245.2	192.7
	57	418.5	37.0	418.5	418.5	392.7	339.6	291.6	241.0	402.8	41.2	402.8	402.8	378.9	325.2	273.9	221.4
16000	77	542.2	38.3	306.8	249.5	192.2	-	-	-	512.1	42.3	330.2	262.8	201.2	-	-	-
	72	521.1	38.2	388.2	330.9	273.6	216.3	-	-	494.5	42.1	395.9	334.3	272.7	211.1	-	-
	67	500.0	38.1	469.6	412.3	355.0	297.7	240.4	-	476.9	41.8	461.7	405.8	344.2	282.6	221.0	-
	62	459.3	37.0	459.3	444.5	387.2	327.6	272.6	215.3	449.1	41.4	449.1	441.7	380.9	318.2	257.7	196.1
	57	443.4	37.4	443.4	443.4	432.3	370.0	317.7	260.4	423.4	41.4	423.4	423.4	412.2	348.1	289.0	227.4
18000	72	525.6	38.1	417.7	357.6	297.5	237.4	-	-	497.0	42.1	415.9	352.5	289.0	225.5	-	-
	67	504.3	37.9	489.1	446.1	386.0	325.9	265.9	-	479.3	41.8	471.7	428.5	365.1	301.6	238.1	-
	62	463.3	36.9	463.3	455.9	421.1	359.8	300.9	240.8	451.3	41.4	451.3	447.6	403.8	339.7	276.8	213.4
	57	447.2	37.3	447.2	447.2	441.7	379.1	321.5	261.4	425.6	41.4	425.6	425.6	420.0	355.3	293.0	229.6
	72	530.1	37.9	447.2	384.3	321.4	258.5	-	-	499.5	42.1	435.9	370.6	305.3	240.0	-	-
20000	67	508.6	37.8	508.6	480.0	417.1	354.2	291.3	-	481.7	41.8	481.7	451.2	385.9	320.6	255.2	-
	62	467.2	36.7	467.2	467.2	454.9	392.0	329.2	266.3	453.5	41.3	453.5	453.5	426.7	361.3	296.0	230.7
	57	451.0	37.1	451.0	451.0	451.0	388.2	325.3	262.4	427.7	41.4	427.7	427.7	427.7	362.4	297.0	231.7

YD480/ND480 (Continued) (Continued)

Air on Evaporator Coil		Temperature of Air on Condenser Coil															
CFM	WB (°F)	Total Capacity ¹ (MBh)	Total Input (kW) ²	Sensible Capacity (MBh)					Total Capacity ¹ (MBh)	Total Input (kW) ²	Sensible Capacity (MBh)						
				Return Dry Bulb (°F)							Return Dry Bulb (°F)						
				90	85	80	75	70			65	90	85	80	75	70	65
				115°F									125°F				
12000	77	443.0	46.3	267.5	224.4	181.3	-	-	-	423.8	50.8	278.9	236.2	193.6	-	-	-
	72	430.0	46.0	320.6	277.6	234.5	191.5	-	-	413.6	50.3	325.5	282.8	240.1	197.4	-	-
	67	416.9	45.6	373.8	330.7	287.7	244.6	201.6	-	403.4	49.8	372.0	329.3	286.6	243.9	201.2	-
	62	403.3	45.7	403.3	366.2	323.1	280.1	237.0	193.9	401.0	50.6	401.0	369.3	326.6	283.9	241.2	198.5
	57	370.8	45.5	370.8	370.8	338.3	295.2	252.2	209.1	359.3	50.0	359.3	359.3	331.0	288.3	245.6	202.9
14000	77	462.5	46.3	310.5	250.3	195.8	-	-	-	437.9	50.5	328.0	262.8	206.4	-	-	-
	72	448.9	45.9	362.1	307.7	253.2	198.7	-	-	427.4	50.0	368.4	312.0	255.5	199.1	-	-
	67	435.3	45.6	413.8	365.1	310.6	256.1	201.6	-	417.0	49.6	408.9	361.1	304.7	248.2	191.8	-
	62	421.1	45.7	421.1	402.5	348.8	294.4	239.9	185.4	414.8	50.3	414.8	402.6	347.4	291.5	234.5	178.1
	57	387.1	45.5	387.1	387.1	365.2	310.8	256.3	201.8	371.4	49.8	371.4	371.4	351.5	296.3	238.6	182.2
16000	77	482.1	46.3	353.6	276.1	210.2	-	-	-	452.0	50.2	377.0	289.4	219.2	-	-	-
	72	467.9	45.9	403.6	337.7	271.9	206.0	-	-	441.3	49.8	411.4	341.2	271.0	200.8	-	-
	67	453.7	45.6	453.7	399.4	333.5	267.6	201.7	-	430.6	49.3	430.6	392.9	322.7	252.5	182.3	-
	62	438.8	45.7	438.8	438.8	374.6	308.7	242.8	176.9	428.6	50.1	428.6	428.6	368.2	299.2	227.8	157.7
	57	403.5	45.5	403.5	403.5	392.2	326.3	260.4	194.5	383.5	49.5	383.5	383.5	372.1	304.4	231.7	161.5
18000	72	468.4	46.1	414.2	347.3	280.5	213.7	-	-	439.8	50.1	412.4	342.2	272.0	201.8	-	-
	67	454.2	45.7	454.2	410.9	344.1	277.3	210.4	-	429.2	49.6	429.2	393.3	323.1	252.9	182.7	-
	62	439.3	45.9	439.3	439.3	386.5	319.6	252.8	186.0	427.4	50.4	427.4	427.4	369.2	299.5	228.8	158.5
	57	403.9	45.6	403.9	403.9	398.3	331.4	264.6	197.8	382.3	49.8	382.3	382.3	376.6	307.6	236.2	165.9
	72	469.0	46.2	424.7	356.9	289.1	221.4	-	-	438.4	50.4	413.5	343.2	273.0	202.8	-	-
20000	67	454.8	45.9	454.8	422.5	354.7	286.9	219.1	-	427.8	49.9	427.8	393.8	323.5	253.3	183.1	-
	62	439.8	46.0	439.8	439.8	398.4	330.6	262.8	195.0	426.1	50.6	426.1	426.1	370.1	299.9	229.7	159.4
	57	404.4	45.8	404.4	404.4	404.4	336.6	268.8	201.0	381.1	50.1	381.1	381.1	381.1	310.8	240.6	170.3

¹ These capacities are gross ratings. For net capacity, deduct supply air blower motor, MBh. Example: Refer to the appropriate Blower Performance Table for the BHP of the supply air blower motor, MBh = 3.415 x kW and kW = BHP x 0.746 ÷ nameplate rated motor efficiency.

² These ratings include the condenser fan motors and the compressor motors but not the supply air blower motor.

YD600/ND600 Air Handler with M1CZ600A Evaporator Section

Air on Evaporator Coil		Temperature of Air on Condenser Coil															
CFM	WB (°F)	Total Capacity ¹ (MBh)	Total Input (kW) ²	Sensible Capacity (MBh)						Total Capacity ¹ (MBh)	Total Input (kW) ²	Sensible Capacity (MBh)					
				Return Dry Bulb (°F)								Return Dry Bulb (°F)					
				90	85	80	75	70	65			90	85	80	75	70	65
		75°F							85°F								
15000	77	778.4	38.3	415.3	359.0	302.7	-	-	-	739.6	44.5	405.1	348.7	292.3	-	-	-
	72	711.3	40.7	471.4	415.1	358.8	302.5	-	-	679.6	45.7	463.0	406.7	350.3	293.9	-	-
	67	644.1	43.1	527.5	471.2	415.0	358.7	302.4	-	619.5	46.8	521.0	464.7	408.3	351.9	295.5	-
	62	618.5	41.7	618.5	580.0	523.8	467.5	411.2	354.9	599.2	45.6	599.2	560.7	504.3	447.9	391.6	335.2
	57	629.2	40.1	629.2	573.3	517.0	460.7	404.4	348.1	616.4	44.2	616.4	561.2	504.8	448.4	392.1	335.7
17500	77	803.9	38.1	456.4	392.7	329.1	-	-	-	760.9	44.6	443.3	379.7	316.2	-	-	-
	72	734.5	40.5	517.4	453.8	390.2	326.6	-	-	699.1	45.7	506.0	442.5	378.9	315.4	-	-
	67	665.2	42.9	578.5	514.9	451.3	387.7	324.1	-	637.4	46.9	568.7	505.2	441.6	378.1	314.6	-
	62	638.8	41.5	638.8	619.6	569.5	508.3	442.3	378.7	616.4	45.7	616.4	597.1	545.5	482.0	418.4	354.9
	57	649.9	39.9	649.9	621.9	562.2	501.2	435.0	371.4	634.1	44.3	634.1	606.5	546.1	482.5	419.0	355.5
20000	77	829.3	37.9	497.4	426.5	355.6	-	-	-	782.2	44.7	481.5	410.8	340.1	-	-	-
	72	757.8	40.3	563.4	492.5	421.6	350.7	-	-	718.7	45.8	549.0	478.3	407.6	336.9	-	-
	67	686.3	42.7	629.5	558.5	487.6	416.7	345.8	-	655.2	46.9	616.4	545.7	475.0	404.3	333.6	-
	62	659.1	41.2	659.1	659.1	615.2	549.1	473.3	402.4	633.6	45.7	633.6	633.6	586.7	516.0	445.3	374.6
	57	670.6	39.7	670.6	670.6	607.4	541.7	465.5	394.6	651.9	44.3	651.9	651.9	587.3	516.6	445.9	375.2
21750	72	784.2	39.9	617.2	540.1	463.0	386.0	-	-	737.6	45.5	588.6	512.9	437.2	361.5	-	-
	67	710.3	42.3	681.9	612.8	535.7	458.7	381.6	-	672.4	46.6	653.0	585.3	509.6	433.8	358.1	-
	62	682.2	40.8	682.2	682.2	670.1	595.4	515.9	438.8	650.3	45.4	650.3	650.3	626.8	551.1	475.4	399.7
	57	694.3	39.3	694.3	694.3	667.1	592.6	513.0	435.9	669.0	44.0	669.0	669.0	630.0	554.3	478.6	402.9
	72	810.6	39.5	671.0	587.7	504.5	421.2	-	-	756.4	45.1	628.3	547.5	466.8	386.1	-	-
23500	67	734.3	41.9	734.3	667.1	583.9	500.6	417.4	-	689.6	46.3	689.6	624.8	544.1	463.4	382.7	-
	62	705.3	40.5	705.3	705.3	725.0	641.7	558.5	475.2	666.9	45.1	666.9	666.9	666.9	586.2	505.5	424.8
	57	717.9	38.9	717.9	717.9	726.8	643.6	560.4	477.1	686.1	43.7	686.1	686.1	672.7	592.0	511.3	430.6
	72	810.6	39.5	671.0	587.7	504.5	421.2	-	-	756.4	45.1	628.3	547.5	466.8	386.1	-	-
	67	734.3	41.9	734.3	667.1	583.9	500.6	417.4	-	689.6	46.3	689.6	624.8	544.1	463.4	382.7	-
		95°F							105°F								
15000	77	700.8	50.7	394.8	338.4	281.9	-	-	-	643.6	56.8	367.7	311.4	255.1	-	-	-
	72	647.9	50.6	454.7	398.2	341.8	285.3	-	-	603.3	56.7	434.4	378.1	321.8	265.5	-	-
	67	595.0	50.4	514.5	458.1	401.6	345.2	288.7	-	563.1	56.6	501.2	444.9	388.6	332.3	276.0	-
	62	579.8	49.5	579.8	541.3	484.9	428.4	371.9	315.5	542.8	55.9	542.8	508.1	451.8	395.5	339.2	282.9
	57	603.6	48.3	603.6	549.1	492.7	436.2	379.7	323.3	564.5	55.9	564.5	510.2	453.9	397.6	341.3	285.0
17500	77	717.9	51.1	430.2	366.7	303.3	-	-	-	663.4	56.8	416.1	342.4	277.3	-	-	-
	72	663.7	50.9	494.6	431.1	367.6	304.2	-	-	621.9	56.7	480.2	415.1	350.0	284.9	-	-
	67	609.5	50.8	559.0	495.5	432.0	368.6	305.1	-	580.5	56.7	544.4	487.8	422.7	357.5	292.4	-
	62	594.0	49.8	594.0	574.7	521.6	455.7	394.6	331.2	559.6	56.0	559.6	542.3	491.3	425.0	361.0	295.9
	57	618.3	48.7	618.3	591.1	530.0	463.9	403.0	339.6	581.9	55.9	581.9	554.8	493.5	427.0	363.2	298.1
20000	77	735.0	51.5	465.6	395.1	324.6	-	-	-	683.2	56.9	464.5	373.4	299.5	-	-	-
	72	679.5	51.3	534.5	464.0	393.5	323.0	-	-	640.5	56.8	526.0	452.1	378.1	304.2	-	-
	67	624.1	51.2	603.4	532.9	462.4	391.9	321.5	-	597.9	56.7	587.6	530.7	456.8	382.8	308.9	-
	62	608.1	50.2	608.1	608.1	558.3	483.0	417.3	346.8	576.4	56.0	576.4	576.4	530.7	454.4	382.8	308.9
	57	633.1	49.0	633.1	633.1	567.2	491.6	426.3	355.8	599.3	56.0	599.3	599.3	533.0	456.5	385.1	311.1
21750	72	690.9	51.1	560.0	485.7	411.3	337.0	-	-	648.5	56.6	546.8	470.5	394.3	318.0	-	-
	67	634.5	50.9	624.1	557.7	483.4	409.0	334.7	-	605.3	56.5	600.2	552.5	476.2	400.0	323.7	-
	62	618.3	49.9	618.3	618.3	583.6	506.8	434.9	360.6	583.5	55.8	583.5	583.5	553.4	476.0	400.9	324.7
	57	643.7	48.8	643.7	643.7	593.0	516.0	444.3	369.9	606.8	55.8	606.8	606.8	555.8	478.3	403.3	327.1
	72	702.3	50.8	585.6	507.4	429.2	351.0	-	-	656.5	56.4	567.5	488.9	410.4	331.9	-	-
23500	67	644.9	50.7	644.9	582.5	504.3	426.1	347.9	-	612.7	56.3	612.7	574.2	495.7	417.2	338.6	-
	62	628.5	49.7	628.5	628.5	608.9	530.7	452.5	374.3	590.7	55.6	590.7	590.7	576.1	497.5	419.0	340.5
	57	654.3	48.5	654.3	654.3	618.7	540.5	462.3	384.1	614.2	55.6	614.2	614.2	578.6	500.0	421.5	343.0
	72	702.3	50.8	585.6	507.4	429.2	351.0	-	-	656.5	56.4	567.5	488.9	410.4	331.9	-	-
	67	644.9	50.7	644.9	582.5	504.3	426.1	347.9	-	612.7	56.3	612.7	574.2	495.7	417.2	338.6	-

YD600/ND600 Air Handler with M1CZ600A Evaporator Section (Continued)

Air on Evaporator Coil		Temperature of Air on Condenser Coil															
CFM	WB (°F)	Total Capacity ¹ (MBh)	Total Input (kW) ²	Sensible Capacity (MBh)						Total Capacity ¹ (MBh)	Total Input (kW) ²	Sensible Capacity (MBh)					
				Return Dry Bulb (°F)								Return Dry Bulb (°F)					
				90	85	80	75	70	65			90	85	80	75	70	65
				115°F						125°F							
15000	77	586.4	62.8	340.6	284.5	228.3	-	-	-	529.2	68.8	313.5	257.5	201.5	-	-	-
	72	558.8	62.8	414.2	358.1	301.9	245.8	-	-	514.2	68.8	394.0	338.0	282.0	226.0	-	-
	67	531.1	62.7	487.8	431.7	375.5	319.4	263.2	-	499.2	68.9	474.4	418.4	362.5	306.5	250.5	-
	62	505.9	62.3	505.9	475.0	418.8	362.7	306.5	250.4	468.9	68.7	468.9	441.8	385.8	329.8	273.8	217.9
	57	525.3	63.4	525.3	471.3	415.2	359.0	302.9	246.7	486.2	70.9	486.2	432.4	376.4	320.4	264.4	208.5
17500	77	608.8	62.6	402.0	318.1	251.3	-	-	-	554.3	68.3	387.9	293.8	225.3	-	-	-
	72	580.2	62.5	465.9	399.1	332.3	265.5	-	-	538.4	68.3	451.6	383.1	314.7	246.2	-	-
	67	551.5	62.5	529.8	480.1	413.3	346.5	279.7	-	522.4	68.3	515.2	472.4	404.0	335.5	267.1	-
	62	525.2	62.1	525.2	509.8	461.0	394.2	327.4	260.6	490.9	68.2	490.9	477.3	430.7	363.5	293.8	225.4
	57	545.4	63.2	545.4	518.4	457.0	390.2	323.4	256.6	509.0	70.4	509.0	482.1	420.5	353.3	283.6	215.1
20000	77	631.3	62.4	463.4	351.8	274.3	-	-	-	579.4	67.8	462.4	330.1	249.2	-	-	-
	72	601.5	62.3	517.6	440.2	362.7	285.3	-	-	562.6	67.8	509.2	428.3	347.3	266.4	-	-
	67	571.8	62.3	571.8	528.6	451.2	373.7	296.3	-	545.7	67.8	545.7	526.4	445.5	364.6	283.7	-
	62	544.6	61.9	544.6	544.6	503.2	425.8	348.3	270.9	512.8	67.7	512.8	512.8	475.7	397.1	313.8	232.9
	57	565.5	63.0	565.5	565.5	498.8	421.4	343.9	266.5	531.8	69.9	531.8	531.8	464.6	386.2	302.7	221.8
21750	72	606.1	62.2	533.5	455.3	377.2	299.0	-	-	563.8	67.7	520.2	440.2	360.1	280.0	-	-
	67	576.2	62.1	576.2	547.3	469.1	390.9	312.8	-	547.0	67.7	547.0	542.0	462.0	381.9	301.8	-
	62	548.7	61.7	548.7	548.7	523.2	445.1	366.9	288.8	514.0	67.6	514.0	514.0	493.1	414.2	332.9	252.9
	57	569.8	62.8	569.8	569.8	518.7	440.5	362.3	284.2	532.9	69.8	532.9	532.9	481.5	402.7	321.4	241.3
	23500	72	610.7	62.0	549.4	470.5	391.6	312.7	-	-	565.0	67.6	531.3	452.0	372.8	293.6	-
67		580.5	61.9	580.5	565.9	487.1	408.2	329.3	-	548.3	67.6	548.3	548.3	478.4	399.2	320.0	-
62		552.9	61.5	552.9	552.9	543.3	464.4	385.5	306.6	515.1	67.5	515.1	515.1	510.5	431.2	352.0	272.8
57		574.2	62.6	574.2	574.2	538.5	459.6	380.8	301.9	534.1	69.7	534.1	534.1	498.4	419.2	340.0	260.8

¹ These capacities are gross ratings. For net capacity, deduct supply air blower motor, MBh. Example: Refer to the appropriate Blower Performance Table for the BHP of the supply air blower motor, MBh = 3.415 x kW and kW = BHP x 0.746 ÷ nameplate rated motor efficiency.

² These ratings include the condenser fan motors and the compressor motors but not the supply air blower motor.

Air Handling Unit and Hot Water Coil Accessory Heating Capacity

ND360 / 1HW0406, ND480 & ND600 / 1HW0407¹

UNIT MODEL	HOT WATER COIL MODEL	GPM	CFM	CAPACITY (MBH)				
				ENTERING WATER TEMPERATURE MINUS ENTRY AIR TEMPERATURE °F.				
				70	90	110	130	150
ND360	1HW0406	50	8,000	236	304	372	440	508
			10,000	265	341	416	492	568
			12,000	291	374	457	540	623
			14,000	315	405	495	585	675
ND480	1HW0407	75	12,800	348	447	547	646	746
			16,000	389	500	611	722	833
			19,200	425	547	668	790	911
ND600		75	16,000	389	500	611	722	833
			20,000	436	561	686	810	935
			24,000	473	610	746	882	1,019

¹ These capacities do not include any blower motor heat.
NOTE: Temperature Water Drop (°F) = (2 X MBH) / GPM.

Hot Water Coil Capacity Correction And Pressure Drop Vs GPM¹

HOT WATER COIL MODEL	GPM	PRESSURE DROP PSI	CAPACITY CORRECTION FACTOR
1HW0406	25	0.4	0.79
	50	1.0	1.00
	75	1.8	1.04
	100	3.4	1.07
1HW0407	50	1.0	0.95
	75	1.5	1.00
	100	2.4	1.03
	125	3.5	1.05

¹ For pressure drop in feet (water), multiply these values by 2.31.

Air Handling Unit and Steam Coil Accessory Heating Capacity

ND360 / 1NF0454

UNIT MODEL	STEAM COIL MODEL	CAPACITY (MBH) @ 2 PSIG ¹				
		CFM	DRY BULB TEMPERATURE OF AIR ENTERING COIL (°F)			
			10	30	50	70
ND360	1NF0454	8,000	535	483	432	380
		10,000	592	535	478	422
		12,000	642	580	518	456
		14,000	687	621	555	489

¹ These capacities do not include any blower motor heat.

Steam Coil Capacity Correction Factors For High Steam Pressure

STEAM PRESSURE (PSIG)	5	10	15	20	25
CAPACITY CORRECTION FACTOR	1.05	1.12	1.19	1.25	1.30

NOTE: Steam Rate = (lbs/Hr.) = 1.025 x MBH

Fan Performance

ND360, 480 & 600 Fan Performance

ND360 Fan Performance Data - 30 Ton

RPM	CFM														
	10,000			11,000			12,000			13,000			14,000		
	SP	BHP	kW	SP	BHP	kW	SP	BHP	kW	SP	BHP	kW	SP	BHP	kW
600	0.20	3.1	2.9	0.02	3.6	3.4	-	-	-	-	-	-	-	-	-
635	0.31	3.3	3.1	0.13	3.8	3.5	-	-	-	-	-	-	-	-	-
700	0.54	3.7	3.5	0.38	4.2	3.9	0.20	4.8	4.5	0.03	5.3	5.0	-	-	-
775	0.85	4.4	4.1	0.70	4.8	4.5	0.54	5.3	5.0	0.39	5.8	5.5	0.20	6.4	6.0
800	0.97	4.7	4.4	0.82	5.1	4.8	0.66	5.6	5.2	0.52	6.1	5.7	0.35	6.7	6.3
875	1.34	5.6	5.2	1.19	6.0	5.7	1.04	6.6	6.2	0.93	7.1	6.6	0.77	7.7	7.2
900	1.47	5.9	5.5	1.33	6.4	6.0	1.17	7.0	6.5	1.07	7.5	7.0	0.90	8.2	7.6
940	1.70	6.5	6.1	1.55	7.0	6.6	1.40	7.7	7.2	1.31	8.3	7.8	1.09	9.0	8.4

ND480 Fan Performance Data - 40 Ton

RPM	CFM														
	12,800			14,400			16,000			17,600			19,200		
	SP	BHP	kW	SP	BHP	kW	SP	BHP	kW	SP	BHP	kW	SP	BHP	kW
600	0.84	6.0	5.2	0.63	7.2	6.2	0.40	8.4	7.2	0.13	9.7	8.4	-	-	-
660	1.19	7.3	6.3	1.00	8.5	7.3	0.78	9.8	8.5	0.50	11.2	9.7	0.19	12.7	11.0
700	1.42	8.2	7.1	1.25	9.4	8.1	1.03	10.7	9.2	0.75	12.2	10.5	0.45	13.7	11.8
760	1.78	9.5	8.2	1.63	10.8	9.3	1.43	12.3	10.6	1.16	13.8	11.9	0.86	15.6	13.5
800	2.02	10.4	9.0	1.89	11.8	10.2	1.69	13.3	11.5	1.43	14.9	12.9	1.14	16.9	14.6
900	2.62	12.8	11.0	2.53	14.5	12.5	2.40	16.0	13.8	-	-	-	-	-	-
930	2.80	13.5	11.6	2.72	15.3	13.2	-	-	-	-	-	-	-	-	-

ND600 Fan Performance Data - 50 Ton

RPM	CFM														
	16,000			18,000			20,000			22,000			24,000		
	SP	BHP	kW	SP	BHP	kW	SP	BHP	kW	SP	BHP	kW	SP	BHP	kW
600	0.82	6.0	5.2	0.59	7.2	6.2	0.35	8.4	7.2	0.08	9.7	8.4	-	-	-
660	1.17	7.3	6.3	0.96	8.5	7.3	0.73	9.8	8.5	0.45	11.2	9.7	0.14	12.7	11.0
700	1.40	8.2	7.1	1.21	9.4	8.1	0.98	10.7	9.2	0.70	12.2	10.5	0.40	13.7	11.8
760	1.76	9.5	8.2	1.59	10.8	9.3	1.38	12.3	10.6	1.11	13.8	11.9	0.81	15.6	13.5
800	2.00	10.4	9.0	1.85	11.8	10.2	1.64	13.3	11.5	1.38	14.9	12.9	1.09	16.9	14.6
900	2.60	12.8	11.0	2.49	14.5	12.5	2.35	16.0	13.8	-	-	-	-	-	-
930	2.78	13.5	11.6	2.68	15.3	13.2	-	-	-	-	-	-	-	-	-

ND360, 480 & 600 Drive Kit Data

UNIT MODEL	DRIVE KIT MODEL NUMBER	BLOWER RPM RANGE	ADJUSTABLE MOTOR PULLEY		FIXED BLOWER PULLEY		BELTS		
			PITCH DIA. (IN.)	BORE (IN.)	PITCH DIA. (IN.)	BORE (IN.)	QTY.	PITCH LENGTH (IN.)	DESIGNATION
ND360	1LD0415	636 - 795	4.0 - 5.0	1 3/8	11.0	1 3/16	2	63.3	A62
	1LD0407	668 - 827	4.2 - 5.2	1 3/8	11.0	1 3/16	2	63.3	A62
	1LD0408	827 - 986	5.3 - 6.3	1 3/8	11.0	1 3/16	2	59.7	A59
ND480	1LD0409	607 - 776	4.3 - 5.5	1 3/8	12.4	1 3/16	2	85.1	B84
	1LD0410	776 - 917	5.4 - 6.6	1 3/8	12.4	1 3/16	2	86.8	B85
ND600	1LD0411	692 - 833	4.8 - 6.0	1 3/8	12.4	1 3/16	2	78.6	B78
	1LD0412	762 - 931	5.4 - 6.6	1 5/8	12.4	1 3/16	2	76.8	B75

ND360, 480 & 600 Motor Kit Data

UNIT MODEL	HP	MOTOR KIT MODEL NUMBER	FRAME SIZE	VOLTAGE (3PH-60-HZ)
ND360	5.0	2LR04605023	184	208/230/460
		2LR04605032		208/230/460
		2LR04605158		575
	7.5	2LP04607133	213	208/230/460
		2LP04607158		575
	10	2LP04610133	215	208/230/460
2LP04610158		575		
ND480	7.5	2LP04607133	213	208/230/460
		2LP04607158		575
	10	2LP04610133	215	208/230/460
		2LP04610158		575
ND600	10	2LP04610133	215	208/230/460
		2LP04610158		575
	15	2LP04615133	254	208/230/460
		2LP04615158		575

ND360, 480 & 600 Motor Overload Elements¹

MOTOR HP	VOLTAGE	MODEL NUMBER
5	208	2MP04704600
	230	2MP04704600
	460	2MP04704900
	575	2MP04705000
7.5	208	2MP04703700
	230	2MP04704500
	460	2MP04704300
	575	2MP04704000
10	208	2MP04701600
	230	2MP04704100
	460	2MP04704200
	575	2MP04704300
15	208	2MP04704400
	230	2MP04701700
	460	2MP04704500
	575	2MP04704600

¹ These units are equipped from the factory with a correctly sized motor starter; overload elements are not factory supplied. Three elements required per unit.

Static Resistance

Static Resistance

Model	CFM	Hot Water Coil	Steam Coil
ND360	10000	0.08	0.11
	11000	0.09	0.14
	12000	0.10	0.17
	13000	0.12	0.20
	14000	0.14	0.23
ND480	12800	0.11	-
	14400	0.13	-
	16000	0.15	-
	17600	0.17	-
	19200	0.20	-
ND600	16000	0.15	-
	18000	0.18	-
	20000	0.21	-
	22000	0.24	-
	24000	0.28	-

Sound Performance

Indoor Sound Power Levels

Model (Tons)	CFM	ESP (IWG)	Blower		Sound Power, dB (10 ⁻¹²) Watts								
					Sound Rating ¹ dB (A)	Octave Band Centerline Frequency (Hz)							
			RPM	BHP		63	125	250	500	1000	2000	4000	8000
ND360 (30)	12000	0.75	755	5.66	86	84	84	82	81	81	77	74	69
ND480 (40)	16000	0.80	800	8.9	92	90	90	88	90	86	84	81	76
ND600 ² (50)	20000	1.13	700	10.7	88	87	87	85	86	82	80	78	73

¹ These values have been accessed using a model of sound propagation from a point source into the hemispheric/free field. The dBA values provided are to be used for reference only. Calculation of dBA values cover matters of system design and the fan manufacture has no way of knowing the details of each system. This constitutes an exception to any specification or guarantee requiring a dBA value of sound data in any other form than sound power level ratings.

² ND600 Combined with M1CZ600 Evaporator Section

Electrical Data**Electrical Data**

UNIT MODEL	HP	FLA	VOLTAGE (3PH-60HZ)	MIN CIRCUIT AMPACITY	MAX. FUSE SIZE (Amps)
ND360	5.0	16.7	208	21	35
		15.2	230	19	30
		7.6	460	10	15
		6.1	575	8	15
	7.5	24.2	208	30	50
		22	230	28	45
		11	460	14	20
		9	575	11	20
	10	30.8	208	39	60
		28	230	35	60
		14	460	18	30
		11	575	14	20
ND480	7.5	24.2	208	30	50
		22	230	28	45
		11	460	14	20
		9	575	11	20
	10	30.8	208	39	60
		28	230	35	60
		14	460	18	30
		11	575	14	20
ND600	10	30.8	208	39	60
		28	230	35	60
		14	460	18	30
		11	575	14	20
	15	46.2	208	58	100
		42	230	53	90
		21	460	26	45
		17	575	21	35

Typical Wiring Diagrams

Air Handling Units

Typical ND360, 480 & 600 Wiring Diagram

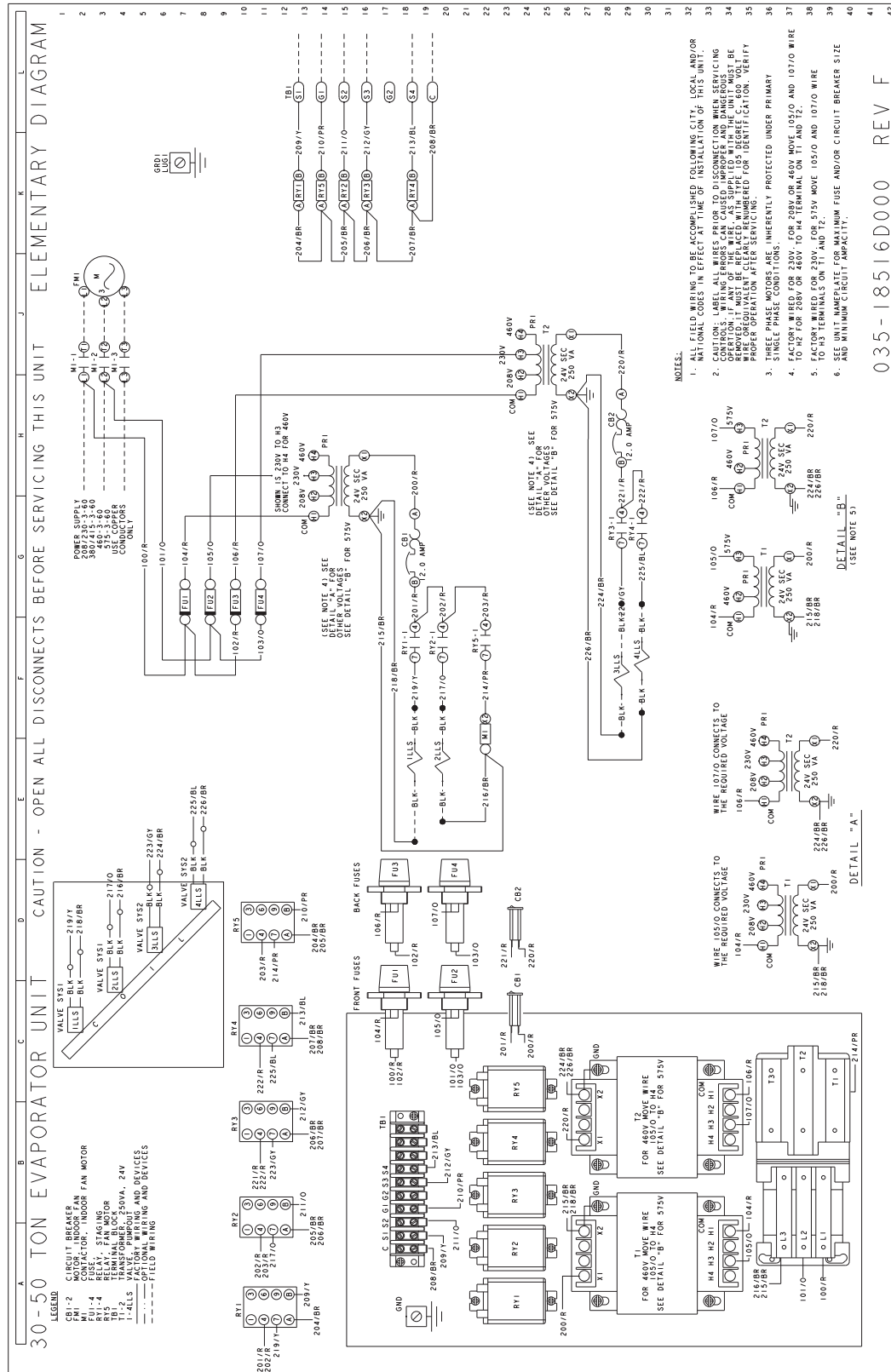

Weights And Dimensions

Corner Weights & Center of Gravity ND360, 480 & 600 Unit

Model	Drive HP	Evaporator Section	Blower Section	Drive Section	Weight (lbs.)		Center of Gravity		4 Point Load Location (lbs.)				6 Point Load Location (lbs.)					
		Cabinet Wt (lb)	Cabinet Wt (lb)	Cabinet Wt (lb)	Shipping	Operating	CG X	CG Y	A	B	C	D	A	B	C	D	E	F
Vertical Airflow																		
ND360	5.0	567	490	110	1122	1184	20.1	44.3	297	363	288	236	200	244	215	191	157	176
	7.5	567	490	134	1122	1208	20.3	44.0	301	376	295	236	202	252	222	197	158	178
	10	567	490	150	1122	1224	20.5	43.8	304	385	299	236	203	257	226	201	159	179
ND480	7.5	654	527	141	1246	1348	24.6	45.1	334	424	330	260	223	283	249	221	174	196
	10	654	527	157	1246	1364	24.8	44.9	336	434	334	259	224	288	254	226	175	197
ND600	10	~	645	155	705	1742 ¹	31.4	46.1	393	570	461	318	267	387	341	303	209	235
	15	~	645	272	705	1859 ¹	32.4	45.0	408	639	496	318	272	426	376	333	213	240
M1CZ600	~	~	~	~	979	~	~	~	~	~	~	~	~	~	~	~	~	~
Horizontal Airflow																		
ND360	5.0	567	490	110.2	1122	1184	36.4	44.3	332	328	260	264	224	221	195	173	175	197
	7.5	567	490	134	1122	1208	36.5	44.0	339	338	265	266	227	226	199	177	178	200
	10	567	490	150	1122	1224	36.6	43.8	345	344	268	268	230	230	202	180	180	203
ND480	7.5	654	527	140.7	1246	1348	43.1	45.1	387	371	288	301	258	248	218	194	202	228
	10	654	527	156.9	1246	1364	43.2	44.9	392	378	291	303	261	251	221	196	204	230
ND600	10	908.5	645	154.9	705	1742 ¹	52.1	46.1	446	517	418	361	303	351	309	275	237	267
	15	908.5	645	271.7	705	1859 ¹	52.5	45.0	480	567	440	373	320	378	333	296	250	282
M1CZ600	~	~	~	~	979	~	~	~	~	~	~	~	~	~	~	~	~	~

¹ Operating weight includes ND600 Airhandler and M1CZ600 Evaporator Coil Combined.

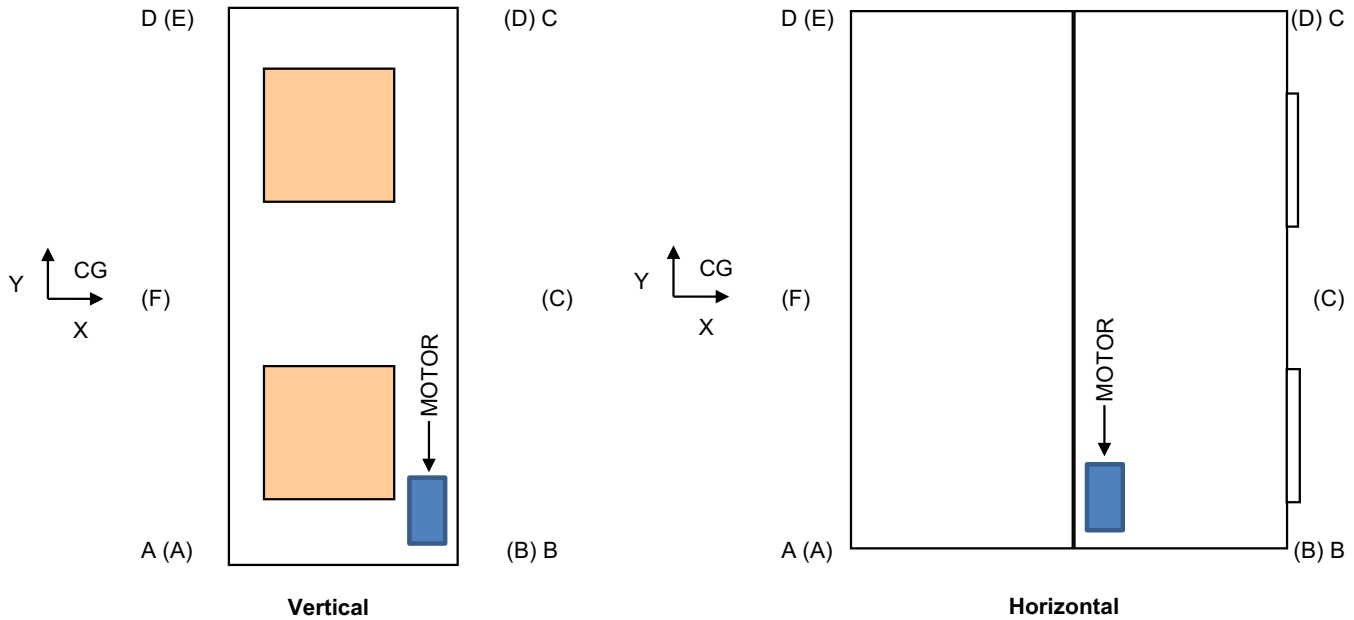

TOP

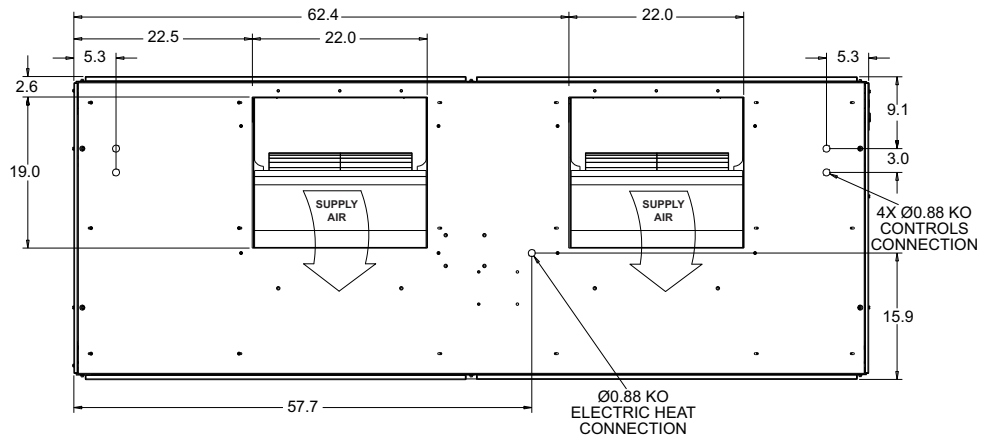

FRONT

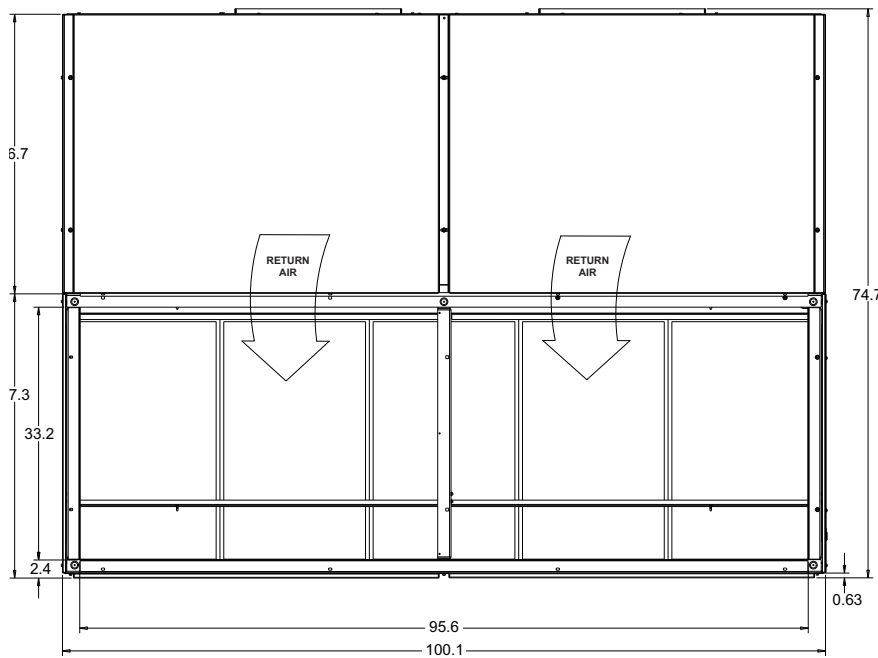

SIDE

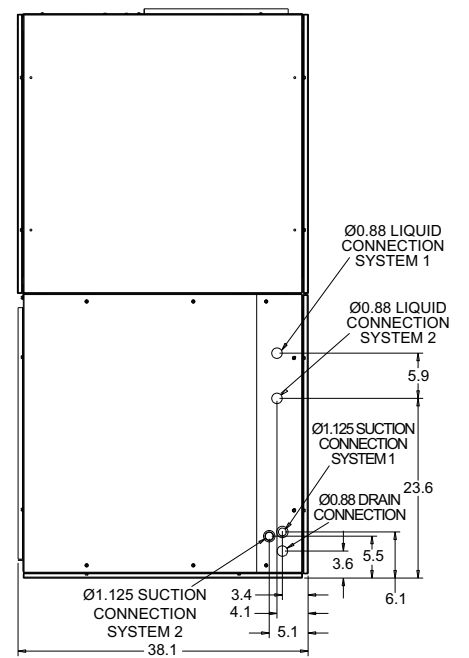

Unit Dimensions ND360

HORIZONTAL CONFIGURATION

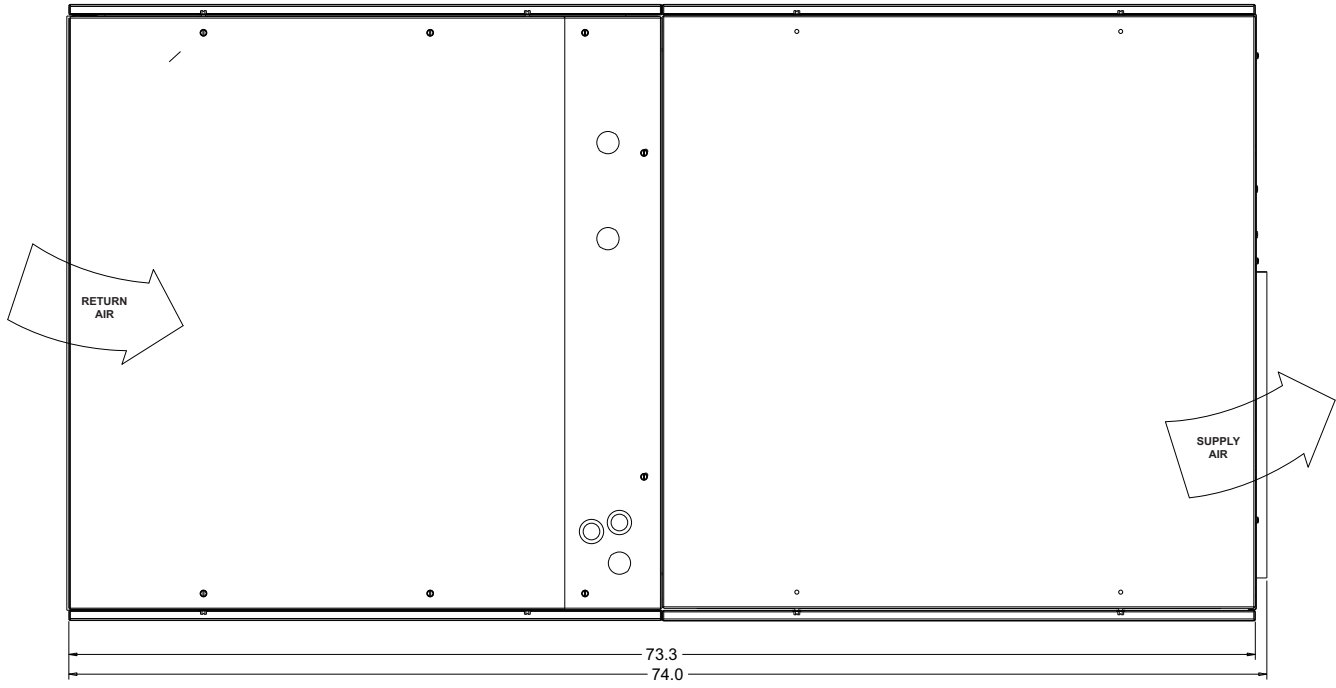

Unit Dimensions ND360 (Continued)

HORIZONTAL CONFIGURATION

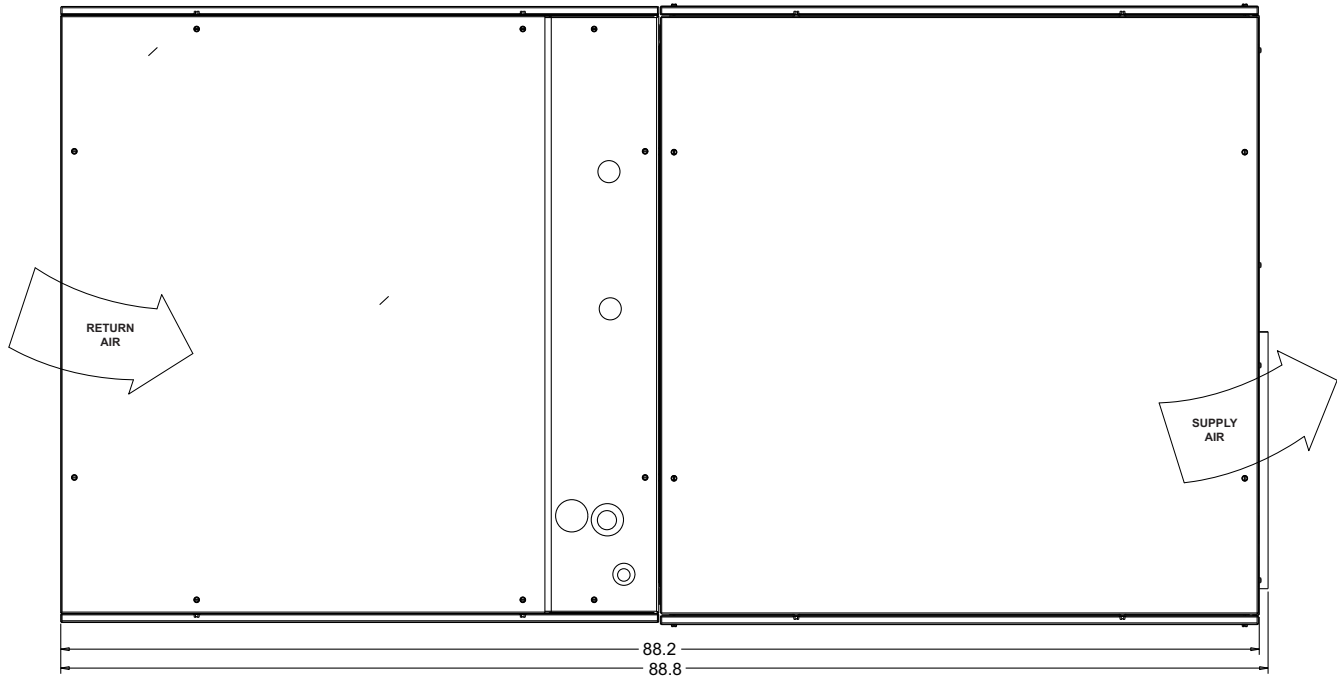

Unit Dimensions ND480 (Continued)

TOP

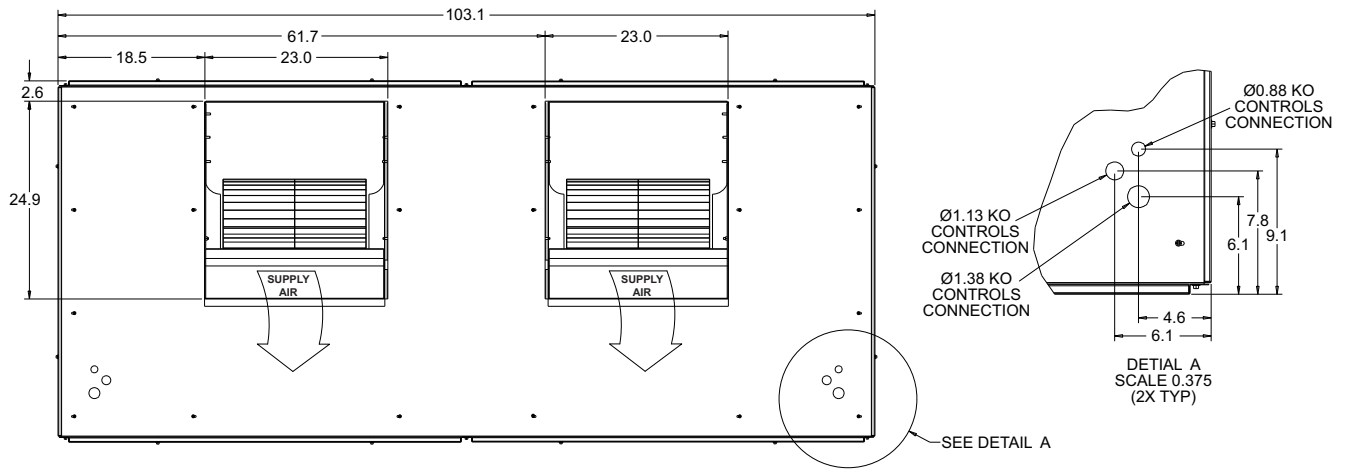

FRONT

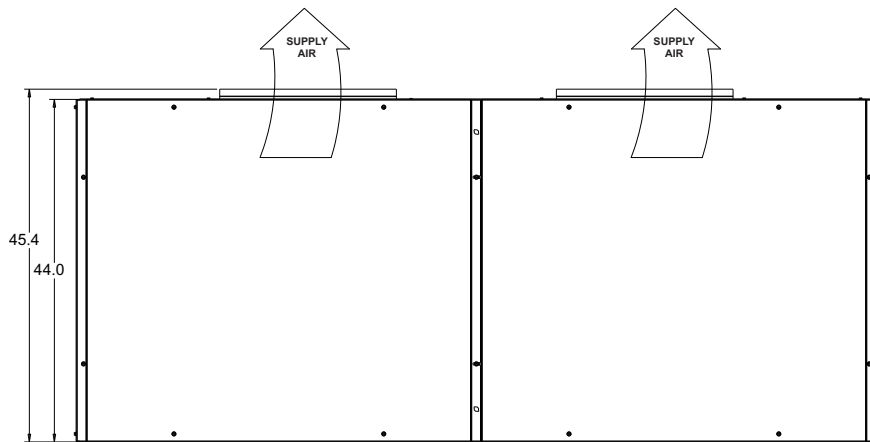

SIDE

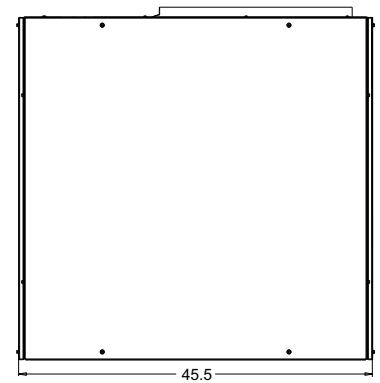

Unit Dimensions ND600

TOP

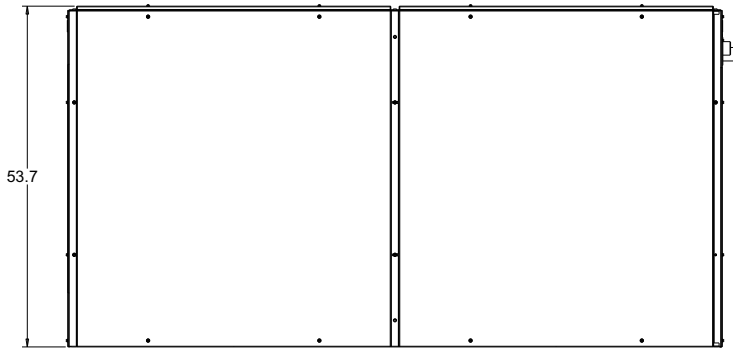

FRONT

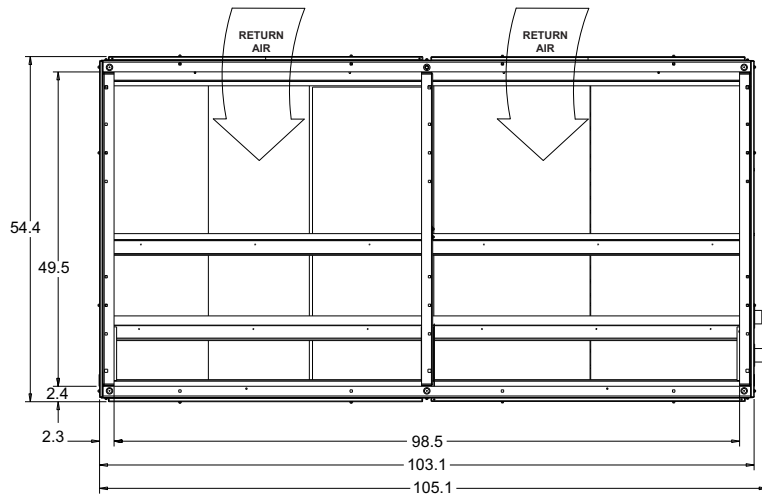

SIDE

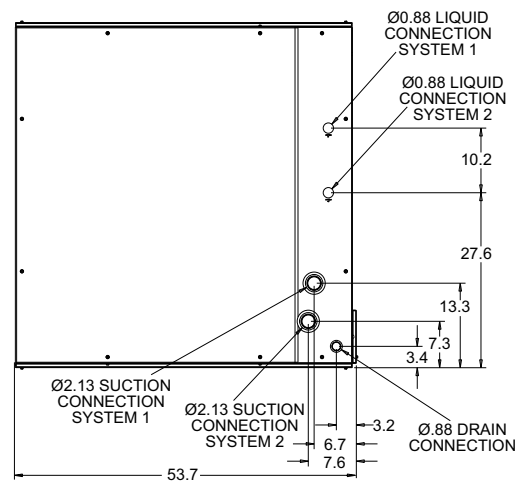

Unit Dimensions M1CZ600 Evaporator Section

VERTICAL CONFIGURATION

FRONT

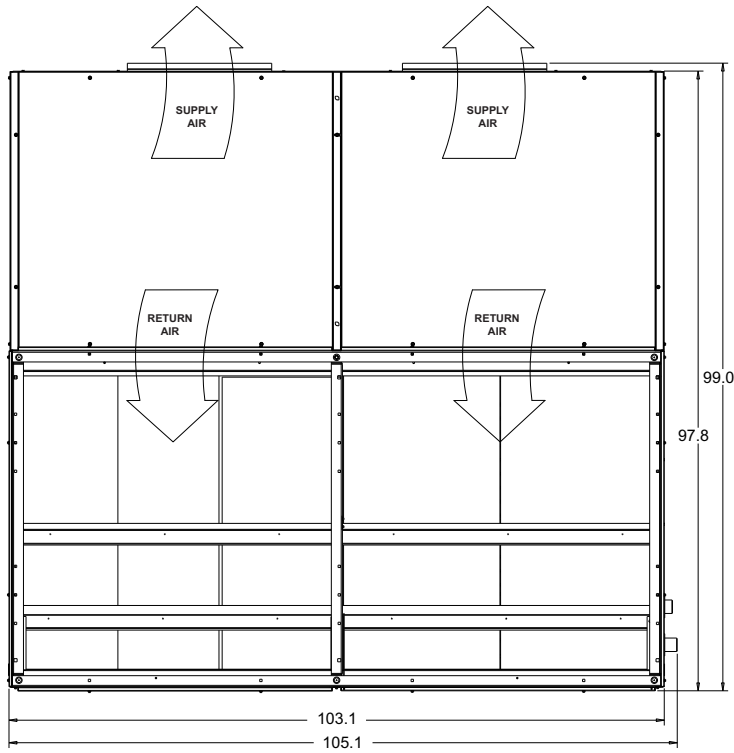

SIDE

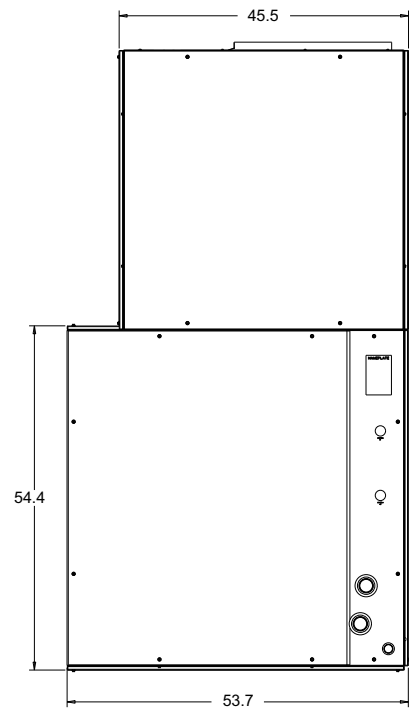

HORIZONTAL CONFIGURATION

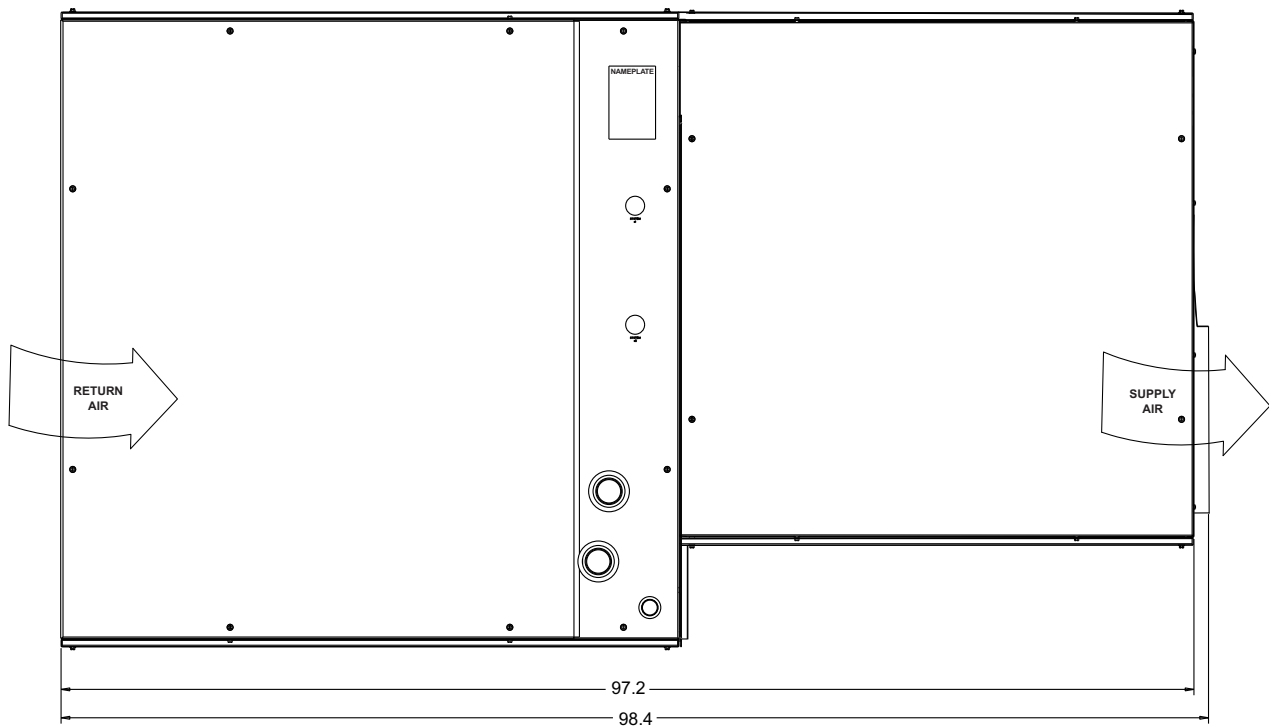

Unit Dimensions ND600 Airhandler & M1CZ600 Evaporator Coil

Unit Connection Sizes

Model	ND360	ND480	ND600	M1CZ600A
Dimensions (inches)				
Length	100.1	103.1	103.1	103.1
Width	38.1	45.4	45.5	53.7
Height	74.7	89.4	45.4	54.4
System Data				
No. Refrigeration Circuits	2	2		2
Suction Line OD (in.)	1 1/8	1 3/8	-	2 1/8
Liquid Line OD (in.)	7/8	7/8	-	7/8
Power Wiring Knockout	7/8	7/8	1 3/8	-
Control Wiring Knockout	7/8	7/8	7/8	-
Drain Line	7/8	7/8	-	7/8
Blower Outlet				
Number	2	2	2	-
Width	19.0	19.0	24.9	-
Length	22.0	22.0	23.0	-
Return Air Inlet				
Width	33.2	40.5	-	49.5
Length	95.6	98.5	-	98.5

Minimum Clearances

Top with Supply Air Opening ¹	24"
Front with Return Air Opening	24"
Right Side with access for Piping, Power & Control Wiring Connections ²	24"
Left Side	24"
Rear ³	N/A
Bottom ⁴	N/A

- ¹ This dimension will vary if a supply air plenum or a base is used.
- ² This dimension is required for normal installation and service.
- ³ Although no clearance is required for service and operation, some clearance may be required for routing the power and control wiring.
- ⁴ Allow enough clearance to trap the condensate drain line.

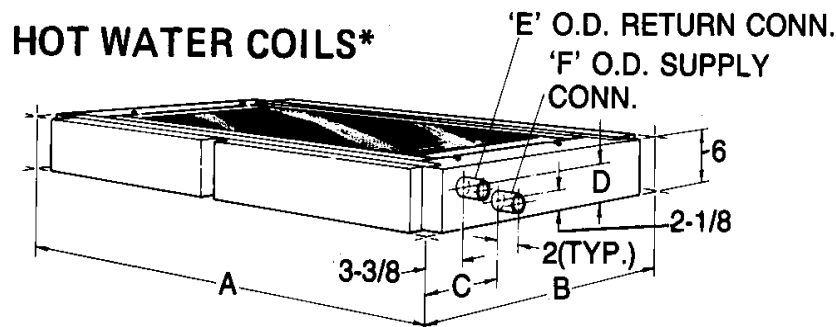

Dimensions Hot Water Coil

Dimensions Hot Water Coil

COIL MODEL	UNIT MODEL	DIMENSIONS					
		A	B	C	D	E	F
1HW0406	ND360	100-1/8	37-7/8	6-3/4	3-7/8	1-3/8	1-3/8
1HW0407	ND480 ND600	103-1/8	45-1/4	6-1/2	4	1-5/8	1-5/8

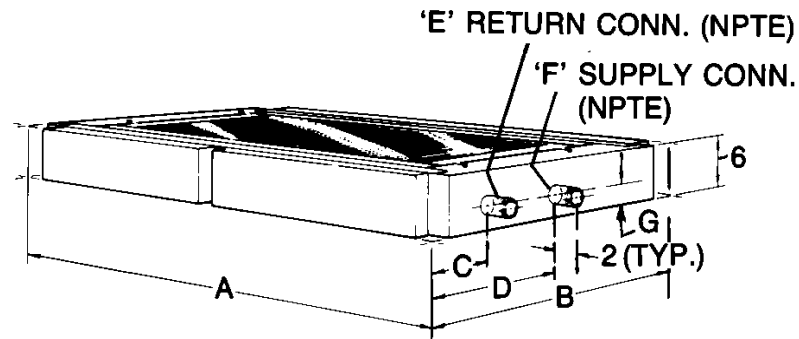

Dimensions Steam Coil

Dimensions Steam Coil¹

COIL MODEL	UNIT MODEL	DIMENSIONS						
		A	B	C	D	E	F	G
1NF0454	ND360	100-1/8	37-7/8	4-3/8	18-3/8	1-1/2	2	2-1/2

¹ Coils are field-installed between the evaporator coil and the blower section of the unit.

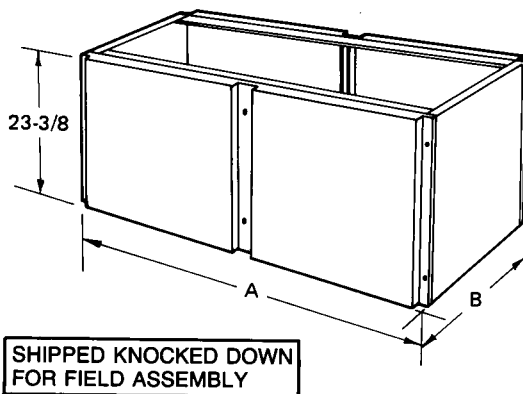

Dimensions Base Section

Dimensions Base Sections¹

BASE MODEL	UNIT MODEL	DIMENSIONS	
		A	B
1BS0406	ND360	100-1/8	37-7/8
1BS0407	ND480	103-1/8	45-1/4

¹ Ventilation air can be brought into the unit through the base section providing the base section is fully insulated in the field.

Unit Mounting

ND360, 480 & 600

The ND Series evaporator units may be suspended from joists with isolation type hangers or hooks. Suspension accessories 1HH0403 (ND360), 1HH0404 (ND480) and 1HH0405 (ND600 Air Handler with M1CZ600 Evaporator Section) may be ordered separately. All Suspension accessories include three suspension channels and hardware. The channels extend across the evaporator section, the heating section (if included) and the blower section. Each channel is to be bolted to both sections as shown in Weight Distribution with Suspension Application Figures. Refer to the Unit Mounting Dimensions Table for mounting details and Corner Weights Tables for unit weight distribution.

hardware. The channels extend across the evaporator section, the heating section (if included) and the blower section. Each channel is to be bolted to both sections as shown in Weight Distribution with Suspension Application Figures. Refer to the Unit Mounting Dimensions Table for mounting details and Corner Weights Tables for unit weight distribution.

ND360 & 480 Mounting Detail

HORIZONTAL UNIT SUSPENDED FROM ABOVE ③

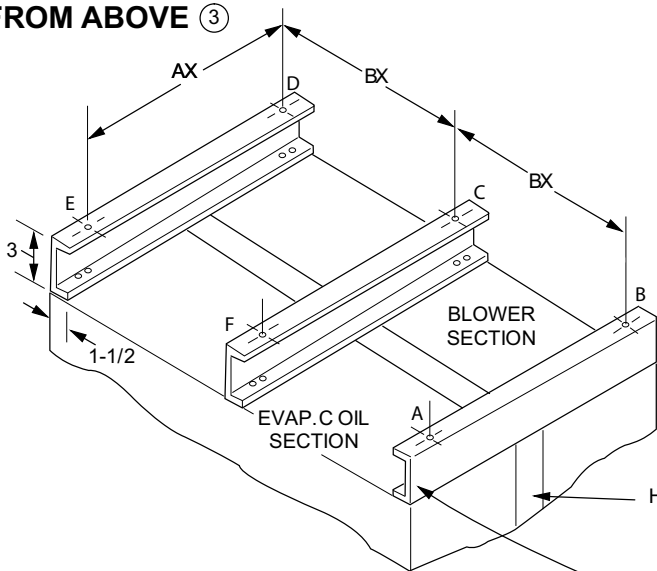

VERTICAL UNIT SUPPORTED FROM BELOW

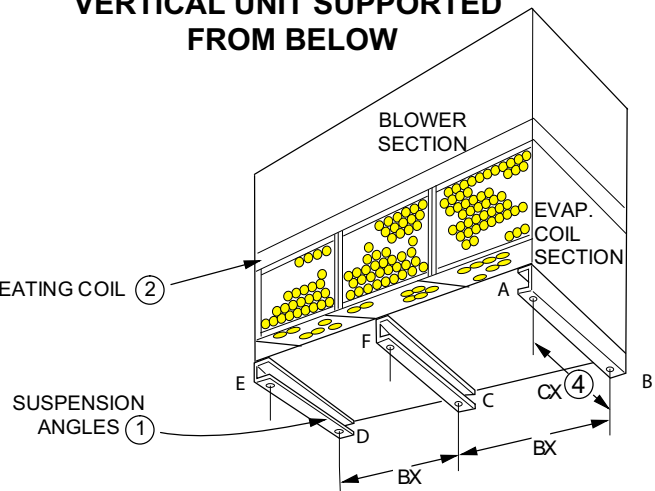

- ① The same channels can be used in either position. When used to support a vertical unit, these channels should be cut to match the bottom dimension of the evaporator section.
- ② The suspension channels have two sets of mounting holes to accommodate horizontal units with or without a heating coil. On a horizontal unit without a heating coil, the suspension channels will extend 3" beyond both ends of the unit.
- ③ The same channels can be used to support a horizontal, floor-mounted unit from below.
- ④ After these bottom channels are cut per Note 1, a new hole will have to be drilled at the cut end if the unit is to be mounted on isolators.

ND480/ND360 Weight Distribution With Suspension Application

NOTE: The following illustration shows how the channels should be secured to the unit using the hardware provided with the suspension accessory.

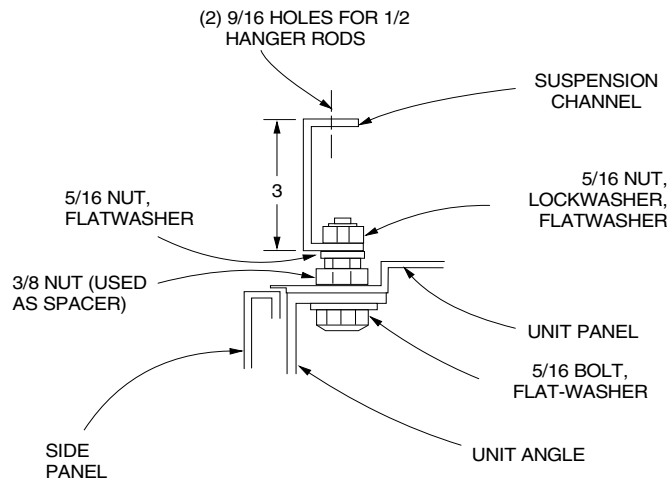

ND360/ND480 Details For Securing Suspension Channels

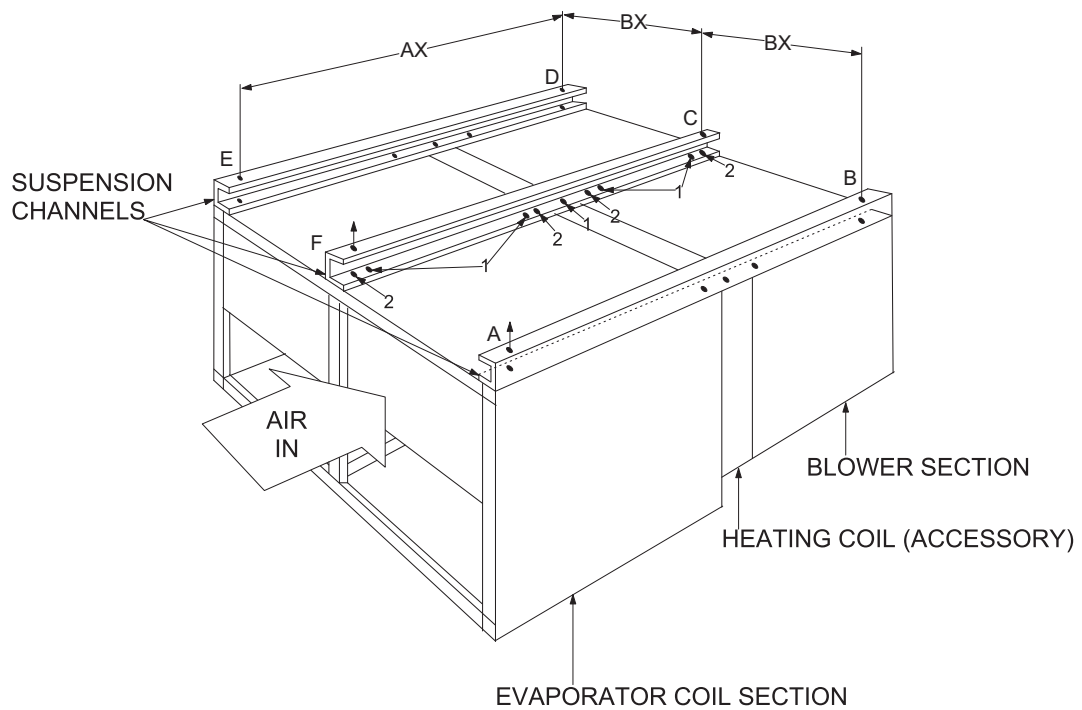

ND600 & M1CZ600 Weight Distribution With Suspension Application

ND600 Mounting Detail

When arranged horizontally, the ND600 airhandler and M1CZ600 evaporator coil can be suspended from joists with hanger rods using a suspension accessory.

The suspension channels require no drilling or cutting. Each channel has enough holes in its bottom flange for:

1. Four bolted connections to the evaporator coil section. (Only two are used on the outside supports)
2. One bolted connection to the heating coil section.
3. Four bolted connections to the blower section. (Only two are used on the outside supports)

See Figure details for securing suspension channels.

When the heating section is not included, each channel will extend 3" beyond the front and the rear of the unit. Bolt holes in the bottom flange of each channel will still align with the holes provided in the top framework of the evaporator section and the blower section.

For both outside channels and for the Point 1 locations on the center channel, the bolted connections are to be made where the top sheet metal panels are attached to the unit framework. The 1/4" screws and cage nuts must be removed and may be discarded. For the Point 2 locations on the center channel, the bolted connections are to be made through the knockouts in the top sheet metal panels. 5/16" cage nuts are provided in the unit framework under these knockout locations. Note that these cage nuts are part of the basic unit. They are not supplied with the suspension accessory.

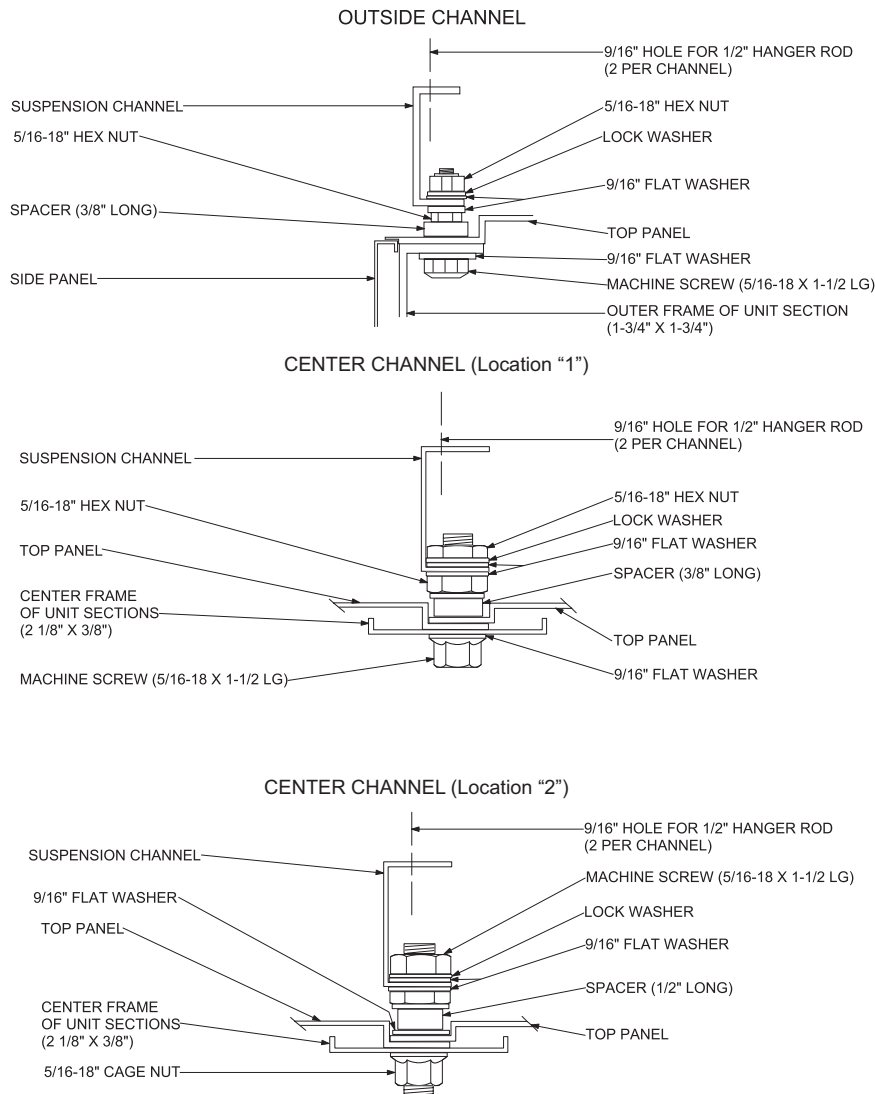

ND600 & M1CZ600 Details For Securing Suspension Channels

Unit Mounting Dimensions

UNIT	DIMENSIONS, INCHES		
	AX	BX	CX
ND360	69-1/4	49-1/16	26-5/8
ND480	84	50-9/16	34
ND600	87	51-1/2	~

Typical Field Wiring Diagrams

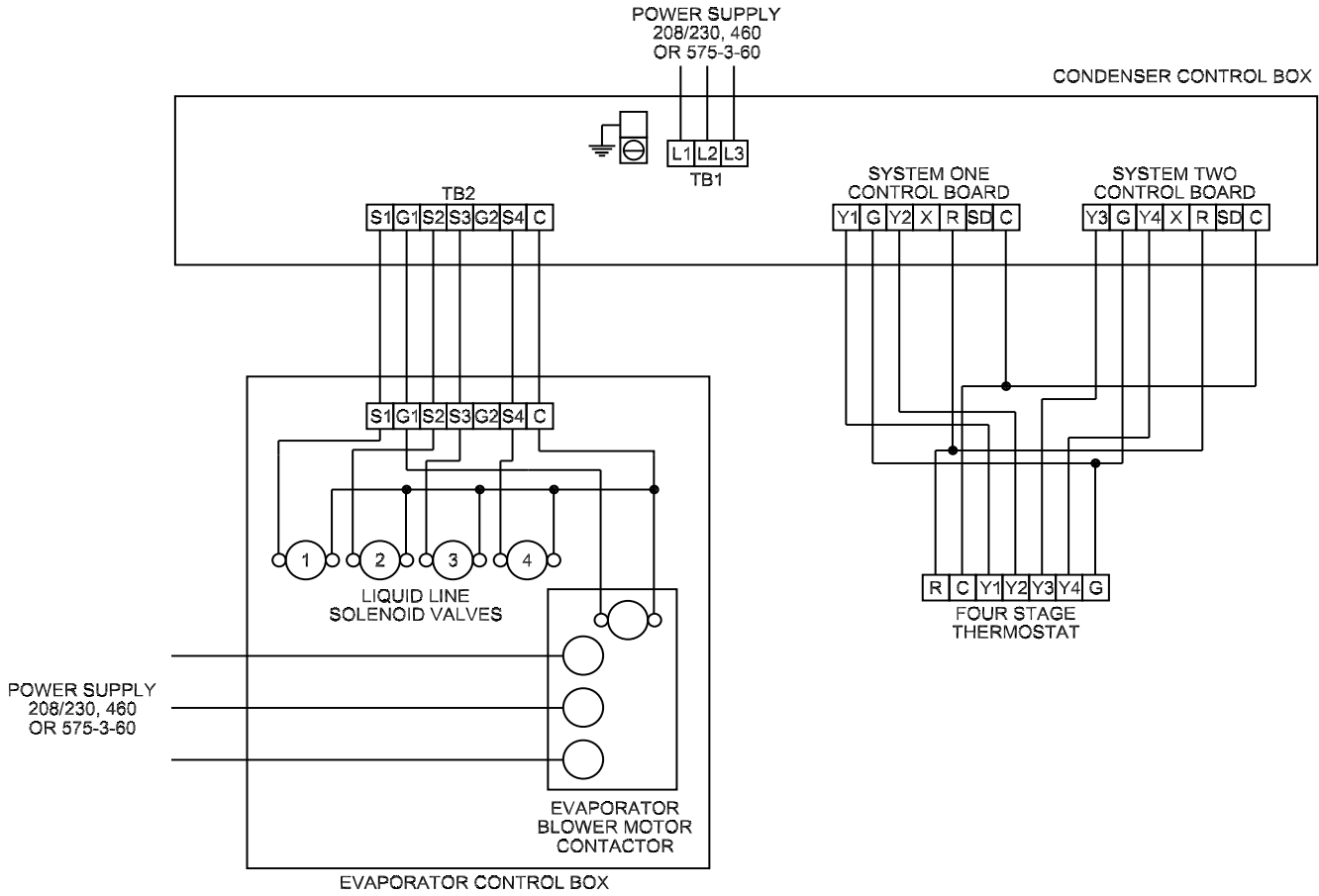

Typical Field Wiring Diagram ND360/480 Evaporator Units, ND600 Air Handler and M1CZ600A Evaporator Coil when Matched with YD360/480/600 Condenser

NOTE: On non ND evaporator models, isolation relays must be installed to avoid overloading on 75VA transformers on the condensing unit.

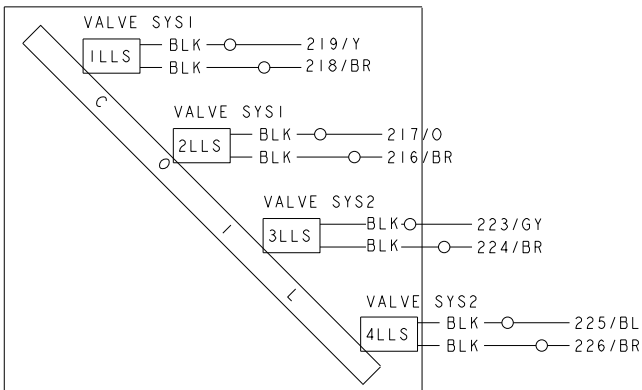

Typical ND360/480 & M1CZ600A Liquid Line Solenoid

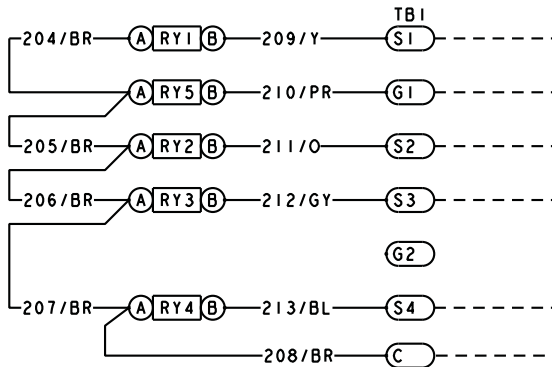

Standard Terminal Block on NC300, ND360/480 and ND600 with M1CZ600A models. On non NC/ND models isolation relays must be installed to avoid overloading on 75 VA transformer on condensing unit.

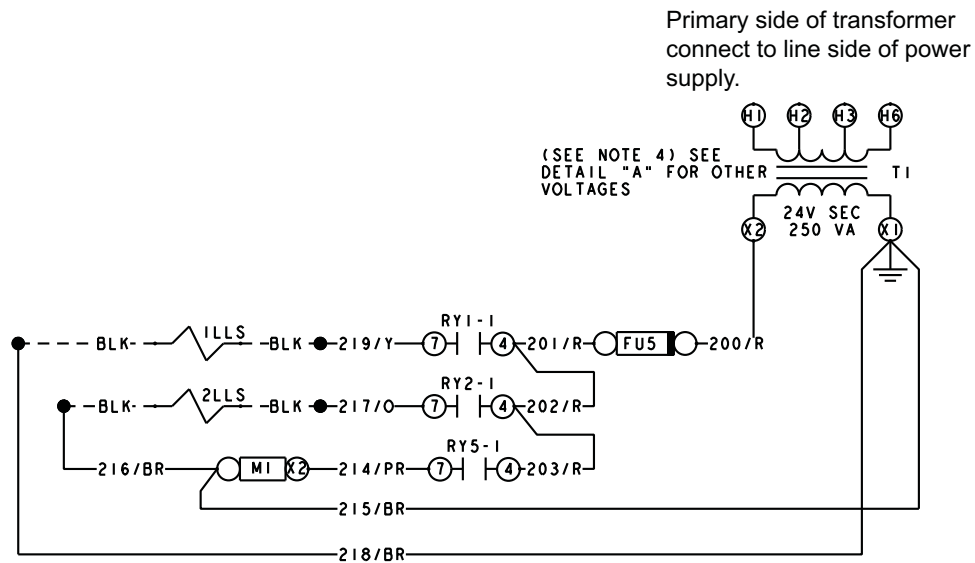

Primary side of transformer connect to line side of power supply.

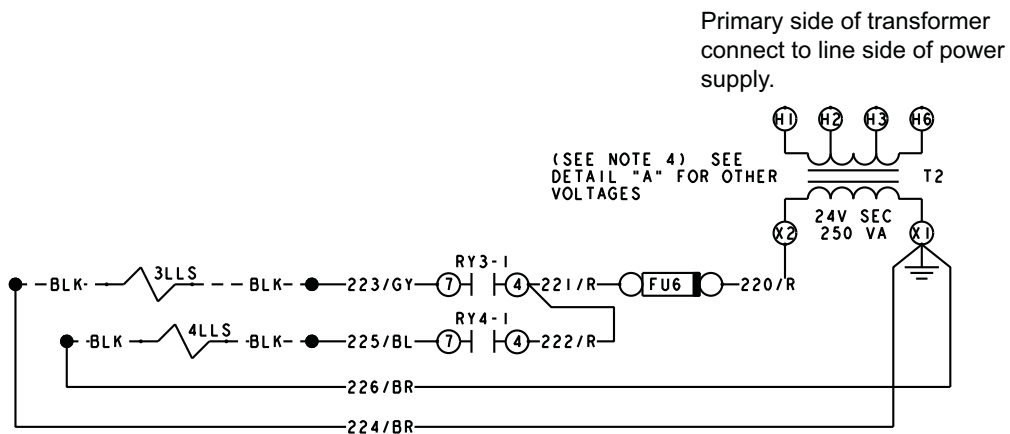

Primary side of transformer connect to line side of power supply.

Non NC/ND units may not include any or all of the components required to wire the unit. Use the diagram as general reference only.

Typical Liquid Line Solenoid Wiring

Subject to change without notice. Printed in U.S.A.
Copyright © 2010 by Johnson Controls, Inc. All rights reserved.

628767-YTG-C-0910
Supersedes: 628767-YTG-B-0810

Johnson Controls Unitary Products
5005 York Drive
Norman, OK 73069