ALL-IN-WONDER® 9700 Series

Installation and Setup User's Guide

P/N: 107-70336-30

Copyright © 2002, ATI Technologies Inc. All rights reserved.

ATI and all ATI product and product feature names are trademarks and/or registered trademarks of ATI Technologies Inc. All other company and/or product names are trademarks and/or registered trademarks of their respective owners. Features, performance and specifications are subject to change without notice. Product may not be exactly as shown in the diagrams.

Reproduction of this manual, or parts thereof, in any form, without the express written permission of ATI Technologies Inc. is strictly prohibited.

Disclaimer

While every precaution has been taken in the preparation of this document, ATI Technologies Inc. assumes no liability with respect to the operation or use of ATI hardware, software or other products and documentation described herein, for any act or omission of ATI concerning such products or this documentation, for any interruption of service, loss or interruption of business, loss of anticipatory profits, or for punitive, incidental or consequential damages in connection with the furnishing, performance, or use of the ATI hardware, software, or other products and documentation provided herein.

ATI Technologies Inc. reserves the right to make changes without further notice to a product or system described herein to improve reliability, function or design. With respect to ATI products which this document relates, ATI disclaims all express or implied warranties regarding such products, including but not limited to, the implied warranties of merchantability, fitness for a particular purpose, and non-infringement.

Product Notices

Dolby* Laboratories, Inc.

Manufactured under license from Dolby Laboratories. Confidential Unpublished Works. (c) 1992-1997 Dolby Laboratories, Inc. All rights reserved.

Macrovision

Apparatus Claims of U.S. Patent Nos. 4,631,603, 4,577,216, 4,819,098, and 4,907,093 licensed for limited viewing uses only.

This product incorporates copyright protection technology that is protected by method claims of certain U.S. patents and other intellectual property rights owned by Macrovision Corporation and other rights owners. Use of this copyright protection technology must be authorized by Macrovision Corporation, and is intended for home and other limited viewing uses only unless otherwise authorized by Macrovision Corporation. Reverse engineering or disassembly is prohibited.

Documentation updates

ATI is constantly improving its product and associated documentation. To maximize the value of your ATI product, you should ensure that you have the latest documentation. ATI's documentation contains helpful installation/configuration tips and other valuable feature information.



IMPORTANT SAFETY INSTRUCTIONS

- **Read Instructions** - All the safety and operating instructions should be read before the product is operated.
- **Retain Instructions** - The safety and operating instructions should be retained for future reference.
- **Heed Warnings** - All warnings on the product and the operating instructions should be adhered to.
- **Compatibility** - This option card is for use only with IBM AT or compatible UL Listed personal computers that have Installation Instructions detailing user installation of card cage accessories.
- **Grounding** - CAUTION: For Continued Protection Against Risk of Electric Shock and Fire, This Accessory Should Be Installed Only In Products Equipped With A Three-wire Grounding Plug, A Plug Having a third (Grounding) Pin. This plug will only fit into a grounding-type power outlet. This is a safety feature. If you are unable to insert the plug into the outlet, contact your electrician to replace the obsolete outlet. Do not defeat the safety purpose of the grounding-type plug.
- All option card securement pins shall be completely tightened as to provide continuous bonding between the option card and the PC chassis.
- **Outdoor Antenna Grounding** - Since an outdoor antenna or cable system is connected to the product, be sure that the antenna or cable system is grounded so as to provide some protection against voltage surges and built-up static charges. Article 810 of the National Electrical Code, ANSI/NFPA 70, provides information with regard to proper grounding of the mast and supporting structure, grounding of the lead-in wire to the antenna discharge unit, size of grounding conductors, location of antenna-discharge unit, connection of grounding electrodes, and requirements for the grounding electrode.
- **Lightning** - For added protection for this product during a lightning storm, or when it is left unattended and unused for long periods of time, unplug it from the wall outlet, and disconnect the antenna or cable system. This will prevent damage to the product due to lightning and power-line surges.
- **Power Lines** - An outside antenna system should not be located in the vicinity of overhead power lines or other light or power circuits, or where it can fall into such power lines or circuits.
- When installing an outside antenna system, extreme care should be taken to keep from touching such power lines or circuits, as contact with them may be fatal.
- **Note to CATV System Installer** - This reminder is provided to call the CATV systems installer's attention to Section 820-40 of the NEC, which provides guidelines for proper grounding and, in particular, specifies that the cable ground shall be connected to the grounding system of the building, as close to the point of cable entry as practical.

Table of Contents

- Getting Started..... 1**
- What is the ALL-IN-WONDER family?..... 1
- System Requirements 3
- Other Sources of Information 4
 - Online Help 4
 - ATI Multimedia Center Guide 4
 - Getting Additional Accessories 4
- Warranty Information 5
 - Product warranty registration 5
 - Customer service 5
 - Hardware warranty service statement 6
 - Warranty service..... 6
 - Limitations..... 7
- Installing the Hardware and Software 9**
- Do This First!..... 9
- Uninstalling Old Graphics Card Software 10
- Installing Your ALL-IN-WONDER Card 11
 - Power connection requirements 12
 - Windows® New Hardware Found 14
 - Installing the CATALYST™ Software Suite..... 14
- Troubleshooting Tips..... 16
- Multiple Display Support 16
 - Increasing the number of colors 17
- Starting the ATI Multimedia Center 18
- Input and Output Adapters 19
 - Selecting the sound card connector for TV audio input..... 23
 - Windows® Volume Control..... 24

Using Your ALL-IN-WONDER 25

- Connecting Your PC to a Video Source 25
- Attaching a TV to Your Card 26
 - Using SCART connectors for European televisions 28
 - Using and adjusting TV Out 29
 - Starting Windows® with television display enabled 29
 - Using a monitor vs. using the television display 29
 - Adjusting the monitor display 30
 - TV reception tips 30
 - Viewing text on television 30
 - Reducing edge distortion 31
 - Changing display configurations 32
 - Using games and applications 32
- multView™ 33
 - multView audio requirements 34
- ATI HDTV Component Video Adapter 35
 - System Requirements 36
 - Setting up your ATI HDTV Component Video Adapter 36
 - Installing your ATI HDTV Component Video Adapter 37
 - Using your HDTV Component Video Adapter 39
 - Windows® Control Panel Settings 39
- Troubleshooting tips 41

Reference 43

- Troubleshooting 43
 - Basic troubleshooting tips 44
 - Troubleshooting tips 45
- Audio and Video Troubleshooting 46
 - Audio problems 46
 - Video problems 48
- CD Audio Connectors 51
- Internal Audio/Video Input Header 52
- To Remove the ATI Multimedia Center 53
- To Remove the ALL-IN-WONDER Drivers 53
- Compliance Information 54
 - FCC Compliance Information 54
 - Industry Canada Compliance Statement 54
 - CE Compliance Information 55

Index 57

CHAPTER 1

Getting Started

Welcome to the convergence of your PC, TV and video! This new technology changes the way you view TV, graphics, and video on your PC.

The ALL-IN-WONDER family of cards are powerful TV tuners, DVD players, Personal Video Recorders, and 2D & 3D graphics and video accelerators. Their features will take your PC's graphics and video capabilities to the next level.

This guide provides all the information you need to install your ALL-IN-WONDER card.

What is the ALL-IN-WONDER family?

The ALL-IN-WONDER family of cards deliver high-performance 3D and 2D graphics, as well as advanced multimedia features. Play games, watch TV or videos, listen to audio CDs, explore the Internet, and work in Windows® as never before.

TV-ON-DEMAND™ and TV Listings enhance your television experience. Using an attached video camera, the ALL-IN-WONDER family provides time-lapse video recording and motion-triggered video recording, which can be used for security applications. Your card's advanced video recording and editing features also give you Video CD and DVD authoring capability.



You can use your ALL-IN-WONDER to connect your computer to a television. This feature is ideal for playing games, giving presentations, watching movies, and browsing the Internet. (For more information, see [Attaching a TV to Your Card](#) on page 26.)

The ALL-IN-WONDER also turns your PC into an intelligent TV with the following features:

- TV-ON-DEMAND™
- THRUVIEW™
- Zoom-in
- Scheduled Viewing
- Channel Scanning
- Video recording
- Closed Captioning with Hot Words™
- Program transcript recording (North America only)
- TV Magazine
- Personal Video Recorder with real-time video compression
- Interactive Program Guide (in selected countries)
- AC-3 Digital Audio playback supporting Dolby® 5.1 surround sound
- REMOTE WONDER™ USB RF remote control (optional)

System Requirements

Computer system	<ul style="list-style-type: none"> • Pentium® 4 / III / II / Celeron™ , AMD® K6/Athlon®, or compatible, with AGP 2X, AGP 8X, or AGP 2X/4X/8X bus slot. • 128MB of system memory. • Installation software requires CD-ROM or DVD drive. • DVD playback requires DVD drive. • Sound card supported by Windows® with available line input. • Interactive Program Guide requires internet connection (North America only). • REMOTE WONDER receiver requires available USB port.
Expansion Slot	AGP 2X, AGP 8X or AGP 2X/4X/8X slot.
Operating System	<p>Windows® 98/SE★, Windows® Me, Windows® 2000, Windows® XP.</p> <p>★The Windows® Me driver installs on Windows® 98/SE.</p>
Monitor	<p>VGA, supporting minimum 640x480 resolution. A Plug-and-Play monitor that supports VESA's Display Channel specifications (DDC1 or DDC2b) is required to take advantage of the DDC1/DDC2b features.</p> <p>The DVI-I interface on ALL-IN-WONDER 9700 Series cards can be used to attach a DVI display or an analog VGA monitor, using the supplied DVI-I-to-VGA adapter.</p> <p>Hydravision™ technology supports DVI or CRT monitor and television.</p>

Other Sources of Information

If you need additional help or require information that is not included in this guide, see the following sources:

Online Help



If you require additional information, you can refer to the online help available under Windows[®] 98, Windows[®] Millennium Edition, Windows[®] 2000, or Windows[®] XP for more information about using ATI's enhanced drivers.



For information on your card's graphics features, double-click the ATI icon in the lower-right corner of your screen.

ATI Multimedia Center Guide

The online *ATI Multimedia Center User's Guide* explains how to use the special features that the ATI Multimedia Center provides. To open the *ATI Multimedia Center User's Guide*:

- 1 Insert the ATI Installation CD-ROM into your CD-ROM drive, then click **User Guide**.

The Online Manual opens in Adobe[®] Acrobat[®] Reader[™]

- 2 Click **User's Guides**, click **ATI Multimedia Center Guides**, then click **ATI Multimedia Center**.

Getting Additional Accessories

Additional and replacement cables, installation CD-ROMs, manuals, and other accessories for ATI products can be purchased from the online ATI store at <http://www.ati.com/online/accessories>.

Warranty Information

Product Warranty Registration

To receive Customer Service, you must register your product with ATI. Online Product Warranty Registration is available at <http://www.ati.com/online/registration>.

Customer Service

For detailed instructions on how to use your ATI product, refer to the Online User's Guide included on your ATI Installation CD-ROM. If you require further assistance with your product, use one of the following options:

Online:

For product information, video drivers, Frequently Asked Questions and Email support, visit:

<http://www.ati.com> and select Customer Service for Built By ATI products.

Telephone:

Available Monday to Friday, 9:00 AM - 7:00 PM EST.

*905-882-2626

*Access to Telephone Support is available to registered users at no additional cost for the first 30 days from the date of purchase (long distance charges may apply). For complete details, please visit: <http://www.ati.com/online/customercare>.

Mail:

ATI TECHNOLOGIES INC.
Attention: Customer Service
33 Commerce Valley Drive East
Markham, Ontario
Canada L3T 7N6

Hardware Warranty Service Statement

Should the product, in ATI's opinion, malfunction within the warranty period, ATI will at its discretion repair or replace the product upon receipt with an equivalent. Any replaced parts become the property of ATI. This warranty does not apply to the software component of a product or a product which has been damaged due to accident, misuse, abuse, improper installation, usage not in accordance with product specifications and instructions, natural or personal disaster, or unauthorized alterations, repairs, or modifications.

For a detailed description of the ATI Hardware Warranty Service Statement visit:

<http://www.ati.com/online/warranty/statement>.

Warranty Service

For warranty service instructions visit:

<http://www.ati.com/online/warranty> or contact one of our Customer Service Representatives using one of the aforementioned means.

- Before shipping any unit for repair, obtain an RMA number for warranty service.
- When shipping your product, pack it securely, show the RMA and serial number of the product on the outside, and ship prepaid and insured.
- ATI will not be held liable for damage or loss to the product in shipment.

Limitations

- This warranty is valid only if the online Product Warranty Registration form at <http://www.ati.com/online/registration> is successfully submitted within 30 days of purchase of said product.
- All warranties for this product, when purchased as a retail product, expressed or implied, will expire three (3) years* from date of original purchase.

**The ATI REMOTE WONDER unit is warranted for 1 year.*

The DV WONDER is warranted for 2 years.

The HDTV Component Video Adapter is warranted for 1 year.

All accompanying cables and accessories are warranted for 90 days.

- No warranties for this product, expressed or implied, shall extend to any person who purchases the product in a used condition.
- The liability of ATI in respect of any defective product will be limited to the repair or replacement of such product. ATI may use new or equivalent-to-new replacement parts. Defective product will be sent in for repair or replacement only.

ATI makes no other representations or warranties as to fitness for a particular purpose, merchantability or otherwise in respect of the product. No other representations, warranties or conditions shall be implied by statute or otherwise.

In no event shall ATI be responsible or liable for any damages, including but not limited to the loss of revenue or profit, arising:

- from the use of the product,
- from the loss of use of the product, as a result of any event, circumstance, action or abuse beyond the control of ATI; whether such damages be direct, indirect, consequential, special or otherwise and whether such damages are incurred by the person to whom this warranty extends or a third party.

CHAPTER 2

Installing the Hardware and Software

Do This First!

To ensure a successful installation of your ALL-IN-WONDER, you **MUST** install AGP Drivers for **non-Intel** Chipset Based Motherboards. **BEFORE** replacing your current graphics card.

Several AGP motherboard manufacturers use non-Intel AGP chipsets. Chipsets include those made by Acer Laboratories (ALI), Silicon Integrated Systems (SIS), and VIA Technologies, Inc. Each non-Intel chipset requires the installation of a custom Virtual GART (AGP) Driver. This driver is required by your new ATI card to function correctly with your motherboard. **It is very important** that the correct AGP driver be installed before installing an AGP video card in your system.



An incorrect or missing GART driver can result in AGP memory not being detected or a black screen after Windows® loads.

To determine what motherboard chipset is present on your system:

- 1** Right-click **My Computer**, then click **Properties**.
- 2** Click the (**Hardware** tab in Windows® 2000 or Windows® XP) **Device Manager** tab, then scroll to the bottom of the device list.
- 3** Click **System Devices**.
- 4** Scroll through the list of System Devices until you find a listing for the AGP controller. The chipset manufacturer's name will appear as the device name.

Once you have determined the chipset manufacturer for your motherboard, obtain and then install the latest AGP drivers from:

VIA Technologies <http://www.viaarena.com>

Acer Laboratories (ALI) <http://www.ali.com.tw>

Silicon Integrated Systems (SIS) <http://www.sis.com>

Advanced Micro Devices (AMD) <http://www.amd.com>

General Motherboard/chipset information

<http://www.motherboards.org>

More information on this topic can be found at

<http://www.ati.com/support/faq/agpchipsetdrivers.html>

Uninstalling Old Graphics Card Software

To ensure successful installation of your ALL-IN-WONDER card, you must uninstall the graphic drivers for the existing graphics card before removing it from your computer.

To uninstall old graphics drivers

With your current graphics card still in your computer:

- 1** Close all applications that are currently running.
- 2** Click **Start, Settings, Control Panel** and select **Add/Remove Programs**.
- 3** Select your current graphic drivers and click **Add/Remove...**
- 4** *The Wizard will help you remove your current display drivers.
- 5** The System should be restarted after the drivers have been removed.



*If the previously-installed graphics card has any additional software installed, they may also need to be removed at this point. (For example, DVD Player, Multimedia applications, etc.)

Installing Your ALL-IN-WONDER Card

You are now ready to install your card.

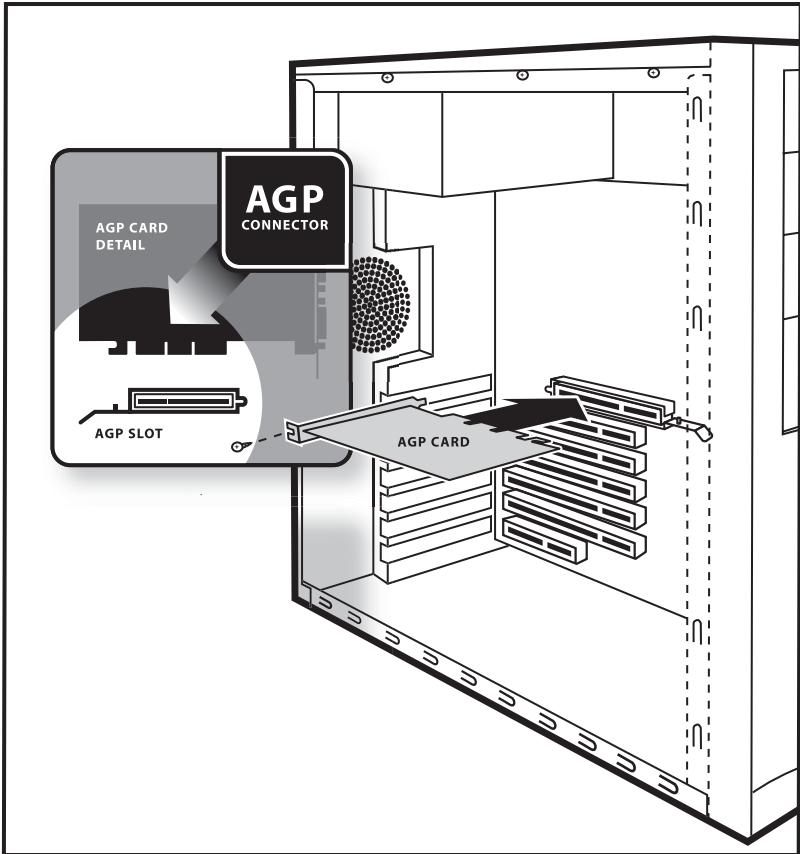

- 1** Power-off the computer and monitor.
- 2** Disconnect the monitor cable from the back of your computer, and disconnect all other connectors from the back of your old video card.
- 3** Remove the computer cover. If necessary, consult your computer's manual for help in removing the cover.



Discharge your body's static electricity by touching the metal surface of the computer chassis.

- 4** Remove any existing graphics card from your computer.
If your computer has an on-board graphics capability, you may need to disable it on the motherboard. For more information, see your computer documentation or contact the manufacturer.

Power connection requirements



The ALL-IN-WONDER 9700 Series cards require connection to your PC's internal power supply for operation. A 300W power supply or greater is recommended to ensure normal system operation where a number of other internal devices are installed.

- Please check the sticker on your power supply to determine the wattage.

After removing the old video card and software, refer to the illustration on [page 13](#), and use the supplied Power Extension Cable to connect the ALL-IN-WONDER 9700 Series card to your computer's Hard Drive power connector.

- 1** Remove the power cable from the Hard Drive, then connect **A** of the Power Extension Cable to the graphics card power connector as shown. (The cable may already be connected to the graphics card.)
- 2** Connect **B** to the power supply connector, then connect **C** to the Hard Drive power connector.
- 3** After locating the AGP slot, and if necessary, removing the metal cover, align your ALL-IN-WONDER 9700 Series card with the AGP slot, and press it in firmly until the card is fully seated.
- 4** Replace the screw to fasten the card in place, and replace the computer cover.
- 5** Plug the monitor cable into your card.

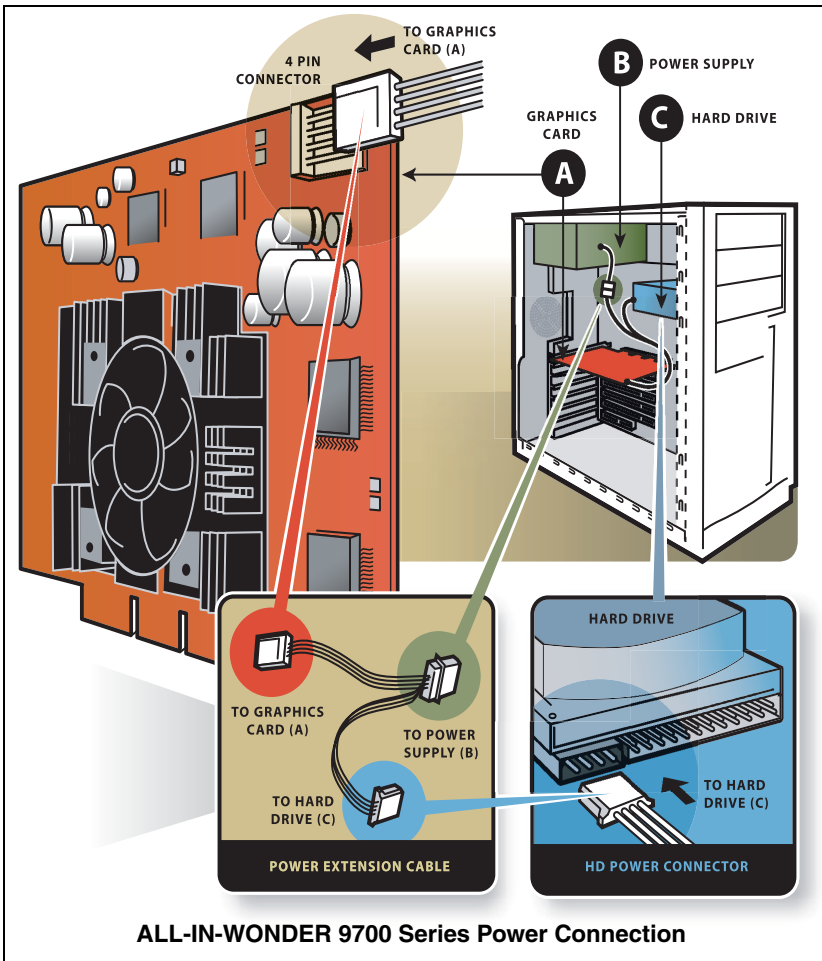

- 6 Turn on the computer and monitor. If your ALL-IN-WONDER card came with a DVI-I connector, you can connect a flat panel display to the appropriate connector, as shown below.

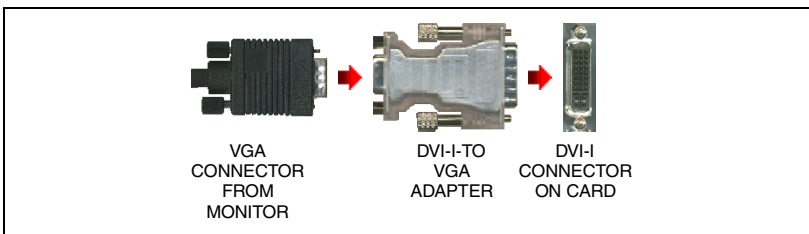

Windows® New Hardware Found

Windows may start the **Add New Hardware Wizard** to install the Standard VGA Driver. To correctly install your new hardware:

If you are using Windows® 2000 or Windows® XP, **Cancel** the Wizard and proceed to *Installing the CATALYST™ Software Suite* on page 14.

- If the **Add New Hardware Wizard** does not appear, proceed to *Installing the CATALYST™ Software Suite* on page 14.
- If the **Add New Hardware Wizard** does appear:
 - 1** Click **Next** to allow Windows® to search for the Standard VGA or Standard PCI Graphics Adapter.
If prompted for the Windows® CD-ROM, insert it into your CD-ROM drive.
 - 2** Type the following: D:\operating system name (for example, **D:\WinME**).
If D is not your CD-ROM drive, substitute the correct drive letter.
 - 3** Click **OK**, click **Finish** to close the Wizard, then restart your computer.

Installing the CATALYST™ Software Suite

ATI's CATALYST software suite provides the ultimate software required to enjoy the full power of your ALL-IN-WONDER card. The CATALYST software suite comprises four, distinct software elements:

- Display driver
- Multimedia Center
- HydraVision (not included in the *Express Install*)
- Remote Wonder Software

To ensure you install the latest software, use the ATI Installation CD-ROM that shipped with your ALL-IN-WONDER card.

To install the CATALYST software suite

- 1** Insert the ATI INSTALLATION CD-ROM into your CD-ROM drive.
If Windows[®] runs the CD-ROM automatically, proceed to step 6.
- 2** Click **Start**, then click **Run**.
- 3** Type the following: **D:\ATISSETUP**
(If **D** is not your CD-ROM drive, substitute **D** with the correct drive letter.)
- 4** Click **OK**, then click **Install** under Software Install.
- 5** Click **Next**, then click **Yes** to the license agreement.
- 6** Click **ATI Easy Install** to begin the Installation Wizard.
- 7** Follow the Wizard's on-screen instructions to complete the installation, then restart your computer

*The **Express** installation option is recommended. The multimedia components will automatically be installed along with the ATI graphics driver.*

***Custom** installation allows you to select individual software components for installation.*

The ATI REMOTE WONDER™ software is automatically installed with the CATALYST software suite. See the *ATI REMOTE WONDER Installation Guide* for installation instructions.



Troubleshooting Tips

- Check that the card is seated properly in the correct slot.
- Ensure the display cable is securely fastened to the card's display connector.
- Make sure that the monitor and computer are plugged in and receiving power.
- If necessary, disable any built-in graphics capabilities on your motherboard. For more information, consult your computer's manual or contact the manufacturer. (NOTE: Some manufacturers do not allow the built-in graphics to be disabled or to become the secondary display.)
- Make sure you selected the appropriate display device and graphics card when you installed the ATI driver.
- For more troubleshooting tips, right-click the ATI icon in the taskbar and select **Troubleshooting**.
- If you have problems during bootup, start your computer in **Safe Mode**. Press and hold the CTRL key until the Microsoft® Windows® Startup Menu appears on the screen. Then select the number for **Safe Mode**, and press **Enter**. (You can also use F8 to bring up the Microsoft Windows® Startup Menu.) In **Safe Mode**, bring up the **Device Manager** and check for duplicate display adapter and monitor entries if you are only using one graphics card.
- For more assistance, use the **Troubleshooting Guide** located in the Windows® Help or contact your computer manufacturer.
- To contact **ATI Technical Assistance**, see your **Technical Support and Warranty Service** guide

Multiple Display Support

If you use multiple monitors, the ALL-IN-WONDER card must be the primary graphics card. Normally, the system BIOS determines whether the AGP or PCI card will be the primary.

For PCI cards, the system normally assigns priority to the card slots in order of their appearance. Please read the **Readme** file on the ATI Installation CD for the latest information regarding Multiple Display Support.

Increasing the number of colors

1 Right-click on a clear area of your desktop, then click **Properties**.

2 Click **Settings**.

*If you are using multiple monitors, click the monitor icon whose color depth you want to change. If you click a secondary monitor and **Extend my Windows desktop onto this monitor** is not checked, you cannot change that monitor's settings. Each monitor has its own color settings.*

3 In the **Colors** box, select **High Color (16 bit)**, **True Color (24 bit)** or **True Color (32 bit)**.

Your type of monitor and video adapter determine the maximum number of colors.

The ALL-IN-WONDER card's advanced, DirectX 8.1 and OpenGL 3D acceleration gives you detailed color graphics and 3D features like multi-texturing, alpha blending, and fog effects. ALL-IN-WONDER also provides powerful 2D graphics features through the Display Properties pages:

Settings	Customize your desktop settings such as desktop size, screen resolution and color depth, and store various desktop preferences for easy recall later.
Adjustment	Adjust the position and size of your screen, as well as manipulate the screen refresh rate, frequencies and synchronization.
Color Correction	Correct color tone differences between real color values and the way your monitor displays them, and store various color correction preferences for easy recall later.



The ALL-IN-WONDER display drivers on your ATI Installation CD-ROM are the latest and fastest available, but at ATI, we are constantly improving our products, so check the ATI web site at **www.ati.com** for newer software.

- Under CUSTOMER SERVICE, click **find a driver**, and follow the prompts.

Drivers downloaded from the ATI website:

- Double-click the self-extracting executable file to start the installation.



Windows will automatically reboot your system after the drivers are installed.

Starting the ATI Multimedia Center

From LaunchPad.

The LaunchPad

provides a convenient way to start all your Multimedia Center features — just click the one you want. LaunchPad opens automatically when you start your computer, or if you prefer, you can right-click LaunchPad, and uncheck **Load on Startup** in the drop-down menu to disable this feature.



From Windows® taskbar.

- 1** In the Windows taskbar, click **Start**, then point at **Programs ►**.
- 2** Point at **ATI Multimedia Center ►**, then select **CD Audio, DVD, File Player, LaunchPad, Library, TV, Video CD, or Configuration**.



The first time you launch TV, you must complete the Initialization Wizard, which guides you through setting up TV. After that, the Wizard will not run unless you want to re-run it.

For information on the ATI Multimedia Center, see the online help.

Input and Output Adapters

Your ALL-IN-WONDER card uses input and output adapters that let you connect audio and video devices to the card — TV, VCR, laserdisc player, or camcorder.



To hear sound when you use your ALL-IN-WONDER card's TV feature, ensure that the ALL-IN-WONDER card's output cable is connected to the **line-in** connector of your sound card: see [page 21](#). For information on the CD audio connectors see [page 51](#).

ALL-IN-WONDER Card Connectors

- 1 Video In
- 2 CATV In
- 3 Video Out
- 4 DVI-I / VGA Out (Your card may have either connector.)

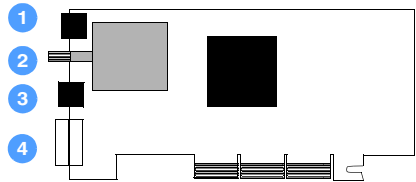

ALL-IN-WONDER 9700 Series Card

To watch movies on your PC or record video from your VCR, camcorder, or laserdisc player

Use the ATI input adapter to connect a VCR, camcorder, or laserdisc player to your ALL-IN-WONDER 9700 Series card, as shown.



The audio and video **output** connectors on your VCR, camcorder, or laserdisc player will be similar to these. Use composite video out **or** S-video out. S-Video will provide better results.

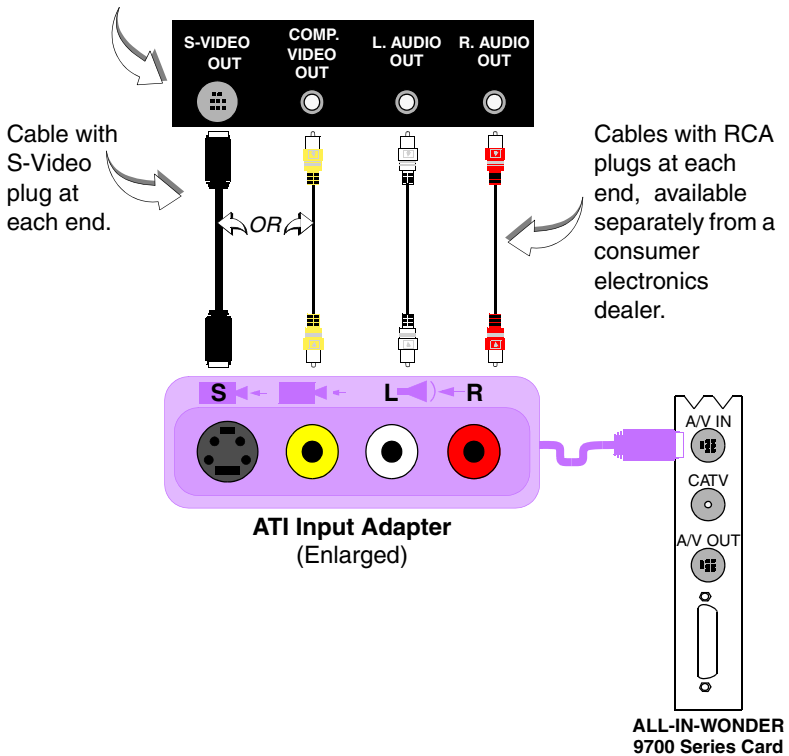

To display your PC output on TV and record your PC output on videotape

Use the ATI output adapter to connect a TV, camcorder, or VCR to your ALL-IN-WONDER 9700 Series card, as shown.



The audio and video **input** connectors on your TV, camcorder, or VCR will be similar to these. Use COMPOSITE VIDEO IN **or** S-VIDEO IN. S-Video will provide better results.

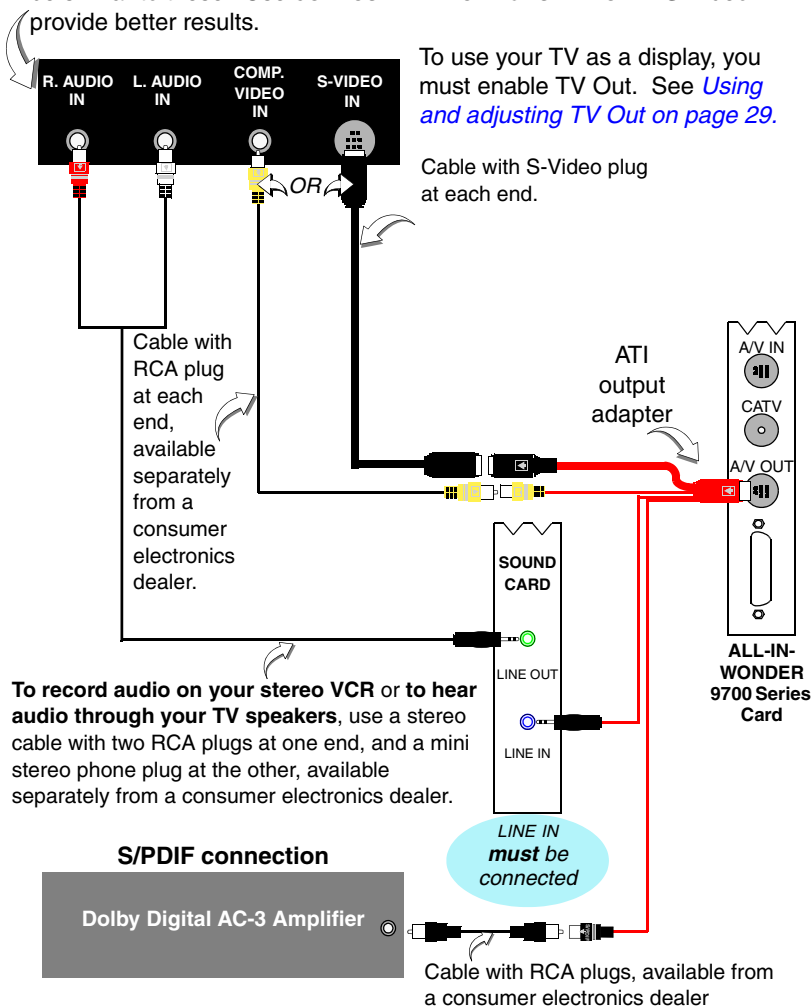

To display your PC output on a High Definition TV

Use the ATI component video adapter to connect a High Definition TV to your ALL-IN-WONDER 9700 Series card, as shown.

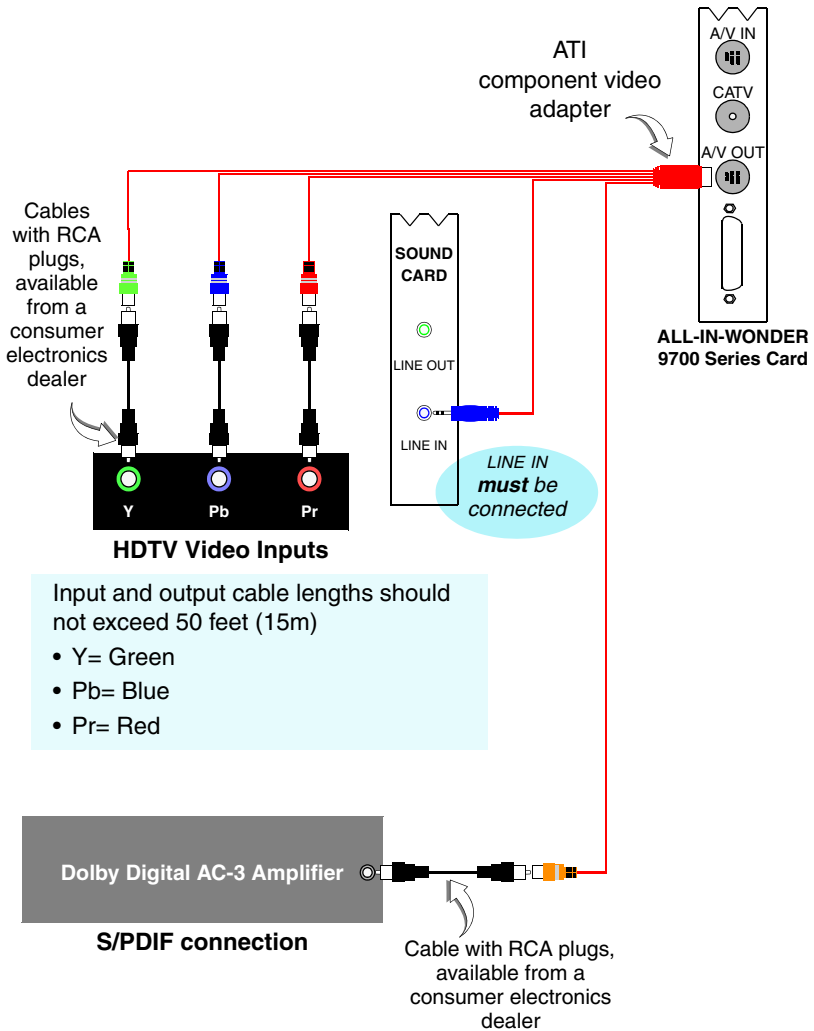

Selecting the sound card connector for TV audio input

The sound card connector determines which mixer slider is controlled by the ATI Multimedia Center's volume slider.

- 1**  Click the **Setup** button in the TV Player control panel, then click the **Display** tab.
- 2** Click the **Initialization Wizard** button, then click the **Next** button twice.
- 3** In the **Typical Audio Connections** page, check **I have connected the cable** to confirm that you have connected your ALL-IN-WONDER card's audio output cable to your sound card's Line-In connector.
- 4** Click **Next** to open the TV Sound Initialization Wizard.
- 5** Click the audio input that matches the connection between your ALL-IN-WONDER card and your sound card. (Line-In is the standard audio input when the ALL-IN-WONDER card's audio output cable is connected to the sound card's Line-In connector.) If you are not sure how it is connected, click each source (CD Audio, Line-In, etc.), and listen for the sound.
- 6** Click the **Next** button until you reach the **End of Initialization Wizard** page, then click the **Finish** button.



Ensure that the ALL-IN-WONDER card's audio output cable is connected to your sound card's Line-In connector.

Windows® Volume Control

For correct audio performance, your sound card's line input must be active. To display the Line Input setting in the Windows Volume Control panel:

- 1** Right-click the speaker icon  in the Taskbar (usually in the lower-right corner of your screen), then click **Open Volume Controls**.
- 2** If the Line-In volume slider is not visible, click **Options**, then click **Properties**.
- 3** Click the **Line-In** volume control checkbox, then click **OK**. If the **Mute** checkbox is checked, click it to cancel muting.

If the speaker icon is not in your Taskbar, do the following:

- In the Windows taskbar, click **Start**, point to **Settings**, then click **Control Panel**.
- Double-click **Sounds and Multimedia**.
- In **Sound Volume**, check **Show volume control on Taskbar**.

CHAPTER 3

Using Your ALL-IN-WONDER

For comprehensive information on your ALL-IN-WONDER card's multimedia features, please see the online *ATI Multimedia Center User's Guide* on the Installation CD.

To open the *ATI Multimedia Center User's Guide*:

- 1** Insert the ATI Installation CD-ROM into your CD-ROM drive, then click **User Guide**.

The Online Manual opens in Adobe® Acrobat® Reader™

- 2** Click **User's Guides**, click **ATI Multimedia Center Guides**, then click **ATI Multimedia Center**.

For correct operation of your card's multimedia features, the ALL-IN-WONDER 9700 Series card must be your computer's primary graphics card. For more information, see [Multiple Display Support](#) on page 16.

Connecting Your PC to a Video Source

To connect your computer to a VCR or camcorder, attach a connector cable from the VCR or camcorder to the ATI Input/Output Adapter. Most VCRs and camcorders have a Composite video output, also referred to as a phono jack or RCA output. For detailed instructions, see [Input and Output Adapters](#) on page 19.

Many VCRs and camcorders have another video output called S-Video, which provides a higher quality display than Composite video.



S-Video

To connect a VCR or camcorder to your ALL-IN-WONDER

- 1** Turn off your computer and your VCR or camcorder.
- 2** Ensure your graphics card is installed correctly.
- 3** Determine if your VCR or camcorder has an S-Video or Composite video connection.
- 4** Looking at the back of your computer, locate your graphics card. Using the ATI Input/Output Adapter, attach one end of the cable to your graphics card and the other to your VCR or camcorder.
- 5** Turn on your computer and your VCR or camcorder.

Attaching a TV to Your Card

Using your ALL-IN-WONDER card's Composite or S-Video output, you can connect a television set as your computer's display. You can use your card to view computer output directly on your television. Depending upon your television, you can choose NTSC or PAL formats. You can display images on both the TV and VGA monitor simultaneously.

The ALL-IN-WONDER provides a big-screen experience for entertainment PCs that is ideal for playing games, giving presentations, watching movies, browsing the Internet, and recording videotapes of your computer's display.



DVI digital flat panel and television display cannot be used simultaneously. If you are recording a videotape, you will need a television monitor to view while you record.

To connect your graphics card to a television

- You must attach a TV before enabling TV output
 - In order to record audio on your VCR or hear audio through your TV speakers, you must connect the audio cables (see [page 21](#)).
 - If your television has cable input only, which is the case for older units, you can connect your graphics card to your television using your VCR or an RF modulator (available at most consumer electronics dealers) that accepts audio input. Connect the ALL-IN-WONDER card's audio output to the RF modulator's audio input.
- 1** Turn off your computer and your television.
 - 2** Determine if your television has an S-Video connection or an RCA video-in connection.
 - 3** Looking at the back of your computer, locate your graphics card.
 - 4** Connect the supplied output cable adapter to the A/V OUT connector on the card (see [Input and Output Adapters](#) on page 19).
 - 5** Using a cable with either S-Video or RCA connectors, attach one end of the cable to the output cable adapter and the other to your television.
 - 6** Turn on your computer and your television.

If there is no display, you may need to enable the television output capability; see [Using and adjusting TV Out](#) on page 29. For detailed cabling diagrams and audio connections, see [Input and Output Adapters](#) on page 19.

If you have a television connected to your VCR, you can use the television as your computer's display. For information about connecting a television to your VCR, see the documentation that came with your VCR.



If you have a television connected to a VCR that is connected to the ALL-IN-WONDER card's A/V OUT, and you use the television as your computer's display, copy-protected DVD movies may appear alternately bright and dim.

IMPORTANT INFORMATION for European Customers



Some PC monitors in Europe **cannot** be used simultaneously with television display. When you enable television display in Europe, the refresh rate for the monitor and television is set to 50Hz. Some monitors may not support this refresh rate and could be damaged.

- Please check the documentation supplied with your monitor to see if your monitor supports a refresh rate of 50Hz.

If your monitor does not support 50 Hz (or if you are not sure), then turn off your monitor before turning on your computer when using your television as a display.

For information on disabling television display, see [To enable and disable the television display](#) on page 29.

Some televisions in Europe may use an SCART connection. If you use SCART, please read [Using SCART connectors for European televisions](#) on page 28 before attempting to connect your PC to your television.

Using SCART connectors for European televisions

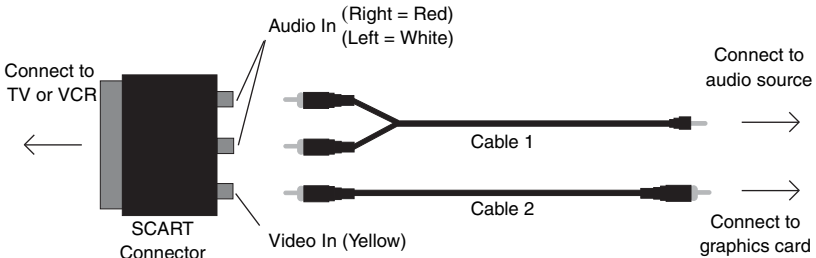

Using an SCART connector with a Composite cable

The SCART connector supports only the Composite video format, which is the most common type. The above illustration shows how to connect to an SCART connector using a Composite cable.

If your television supports S-Video input, you should use an S-Video cable (available in most consumer electronics stores) to view your PC on a television. An S-Video connection provides a higher quality display than Composite video.

Using and adjusting TV Out

To enable and disable the television display

- 1 Click **Start**, point to **Settings**, then click **Control Panel**.
- 2 Double-click **Display**, then click the **Settings** tab.
- 3 Click the **Advanced** button, then click the  **Displays** tab.

*Windows® 98 users: click the **Advanced** button, then click the  **Advanced** tab.*

- 4 Click the green **enable/disable** button next to the word “TV” to enable/disable television display.
- 5 Click **OK** or **Apply** to save the changes you have made.

*For information about how to use television display and the ATI Displays Properties page, click the **Help** button.*

Starting Windows® with television display enabled

The television screen may become scrambled temporarily during the initial Windows® logo display. This is only a temporary effect, and your television screen will be restored within a few seconds.

During start up, your TV Out graphics card will go through a sequence of mode settings, during which your television display will remain blank. This process takes only a few seconds, and helps program the television display.

Using a monitor vs. using the television display

Using your television for your computer’s display is ideal for playing games, giving presentations, watching movies, and browsing the Internet. The display on your monitor may change or look squashed. This occurs because the display adjusts to fit the dimensions of your television. To correct the monitor’s display, use the controls on the monitor to adjust the display size and position.

Older monitors and large, speciality monitors may not work with television display enabled. If you experience problems when television display is enabled, disable television display to restore your monitor's display.

Adjusting the monitor display

The size of the display on your monitor may be smaller and not perfectly centered when you have television display enabled. These effects are caused by the changes required to provide a proper display on the television.

Use the controls available on the Adjustments tab on the Monitor Properties page (click the **Monitor** button on the ATI Displays page) to adjust the display on your monitor only. Click the **Television** button to adjust the television display only.

TV reception tips



- In the TV Tuner tab, ensure that you click the correct setting for cable or antenna.
- For the best indoor antenna reception, use an amplified model, and move it as far away from your monitor as possible.
- If you experience problems with cable input, a signal amplifier may improve reception.

Viewing text on television

Due to the different technology used in the manufacturing of televisions and PC monitors, standard PC text may be unreadable on your television. You can compensate for this by using larger fonts.

To use larger display fonts



- 1** Click **Start**, point to **Settings**, then click **Control Panel**.
- 2** Double-click **Display**, for Windows XP, click the **Appearance** tab. For Windows ME, or Windows 2000, click the **Settings** tab, then click the **Advanced** button.

- 3** In the **General** tab's **Font Size** box, select the size you want your displayed fonts to be.
- 4** To customize the size of displayed fonts, select **Custom** or **Other**.
- 5** Click the **OK** button, then click the **OK** button in the Display Properties dialog.
- 6** Restart your computer.

Reducing edge distortion



When using a television for your PC's display, you may see some edge distortion on the left and right side of your television screen. This effect depends on your television and the PC application you are running. To reduce edge distortion, you can increase the horizontal size.

To increase the horizontal size

- 1** Click **Start**, point to **Settings**, then click **Control Panel**.
- 2** Double-click **Display**, then click the **Settings** tab.
- 3** Click the **Advanced** button, then click the  **Displays** tab.
*Windows® 98 users: click the **Advanced** button, then click the  **Displays** tab.*
- 4** Click the **TV** button.
- 5** Click the **Adjustments** tab.
- 6** Click the plus (+) button under Horizontal Screen to increase the horizontal size of the television display.
- 7** Click **OK** or **Apply** to save the changes you have made.

You can also reduce edge distortion by increasing the TV's contrast.

To increase the TV contrast

- 1** Click **Start**, point to **Settings**, then click **Control Panel**.
- 2** Double-click **Display**, then click the **Settings** tab.
- 3** Click the **Advanced** button, then click the  **Displays** tab.
*Windows® 98 users click the **Advanced** button, then click the  **Advanced** tab.*
- 4** Click the **TV** button.
- 5** Drag the **Contrast** slider to the right to increase the contrast.
- 6** Click **OK** or **Apply** to save the changes you have made.

Changing display configurations

If you move your computer to a place where you are using television display only, make sure that you have the television display feature enabled first; see [To enable and disable the television display](#) on page 29.

Using games and applications

Some older games and applications may program the graphics card directly to run under a specific display mode. This may cause your television display to turn off automatically or become scrambled (the PC monitor will not be affected). Your television display will be restored once you exit the game or if you restart your system.

multView™

If you have an ALL-IN-WONDER 9700 Series card and an ATI TV WONDER PCI card installed in the same system, multView lets you watch a different channel in a secondary video window. You can record video from your ALL-IN-WONDER while you watch another channel on the TVWONDER. The secondary window can be in the following locations:

Picture in Picture (PiP). When the main video window is in full-screen, the multView (PiP) video window is embedded in the main window. It can be positioned in the top/bottom left or top/bottom right of the main window.

Picture outside Picture (PoP). If you use only one monitor, the main and multView video windows can be displayed in separate windows.

If you use dual monitors, you can drag the multView window to the secondary monitor. multView can be displayed in a window or full-screen in the secondary monitor.



The first time you start TV, the multView Initialization Wizard will guide you through setting up the multView window location and the multView tuner audio connection.

multView controls include channel up/down, Mute/unmute, audio, swap channel, volume slider, and channel status. When multView is in focus, you can also type a channel number or name to change channels.

To enable multView

In the multView Initialization Wizard, click **Enable multView**.

To open and close multView

- 1** Right-click the control panel or the video panel.
- 2** In the Feature menu, click **multView**, then click **Show**. To close multView click the Close button .
 - Or right-click the control panel or the video panel.
 - In the Feature menu, click **multView**, then click **Show**.

To change the location of the multView window

When the main video window is in full screen, right-click the control panel or the video panel, click **multView**, click **Location**, then click the position you want: Top-Left, Top-Right, Bottom-Right, or Bottom-Left.

You can manually change the embedded window's size and location when the multView borders are visible.

Autohiding multView window controls and borders

The multView window borders disappear after a few seconds of mouse inactivity on the multView window. When you move your mouse over the multView window, the border reappears.

Only one video window can be in control. When the embedded multView window is in focus, its borders are red; when it is not in focus, its borders are black. For example when the borders are red, a REMOTE WONDER channel-change command will change the multView channel.

multView audio requirements

If you have one audio card or an integrated audio chip, you must connect one audio path internally (CD-In, for example) and the other externally (Line-In, for example).

If you have two audio cards or one audio card and an integrated audio chip, you can connect both audio paths internally, externally, or one internally and the other externally.

ATI HDTV Component Video Adapter



The HDTV Component Video Output Adapter is an optional component for use in North America only.

View computer output directly on your High Definition Television or other component input device. Provide a big-screen experience for your PC that is ideal for playing games, giving presentations, watching movies, and browsing the Internet.

The ATI HDTV Component Video Adapter converts standard VGA or DVI-I video output from your ALL-IN-WONDER card to component video that you can display on your High Definition Television or other component input device.

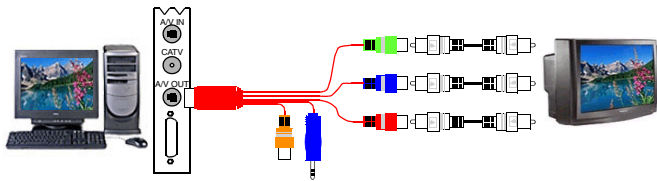

CRT / Analog Flat Panel Monitor



Depending upon the model of your ALL-IN-WONDER 9700 Series card, some of the following features may not be installed:

- Multimedia Center components
- TV applications

System Requirements

Processor	Pentium® 4 / III/ II / Celeron™, AMD® K6 / Athlon®, or compatible.
Graphics Adapter	ALL-IN-WONDER 9700 Series card.
Operating System	Windows® 98/SE*, Windows® Me, Windows® 2000, Windows® XP. *The Windows® Me driver installs on Windows® 98/SE.
Monitor	A CRT monitor is required to install the ATI HDTV Component Video Adapter, and to run DOS applications.
Television	HDTVs or SDTVs that accept component input.

Warranty

The ATI HDTV Component Video Output Adapter is warranted for one year. Accompanying product accessories are warranted for 90 days.



For information on your video card's graphics features, double-click the ATI icon in the lower-right corner of your screen, or go to www.ati.com.

HDTV Kit contents

- ATI HDTV Component Video Adapter
- Installation CD
- Installation and Setup User's Guide

Setting up your ATI HDTV Component Video Adapter

Setting up the ATI HDTV Component Video Adapter consists of two, easy steps.

- **Installing the software** — [page 37](#)
- **Connecting the Adapter** — [page 37](#)

Installing your ATI HDTV Component Video Adapter



You must have a CRT monitor attached to your computer before installing the ATI HDTV.

For proper operation of your ATI Component Video Adapter, ATI display drivers must be correctly installed.

For “Powered by ATI” products:

- 1** Insert the ATI Installation CD that came with your HDTV Component Video Adapter Kit into your CD-ROM drive.
If Windows runs the CD automatically, cancel the installation.
- 2** In Windows Explorer or My Computer, double-click the CD icon, and search for AIB_DRV.
- 3** When Windows finds AIB_DRV, double-click it, follow the on-screen prompts, then go to Step 5, below.

For “Built by ATI” products

- 1** Insert the ATI Installation CD that came with your HDTV Component Video Adapter Kit into your CD-ROM drive.
If Windows runs the CD automatically, go to step 4.
- 2** Click **Start**, then click **Run**.
- 3** Type the following:
D:\Setup
(If **D** is not your CD-ROM drive, substitute the correct drive letter.)
- 4** Click **OK**, and follow the on-screen prompts.
- 5** Shut down your computer.
- 6** Plug the ATI HDTV Component Video Adapter into the A/V Out connector on your ALL-IN-WONDER card.
 - Digital flat panel displays use the VGA-to-YpbPr adapter.
- 7** Using the appropriate cables, connect the ATI HDTV Component Video Adapter’s outputs to your HDTV’s video inputs.

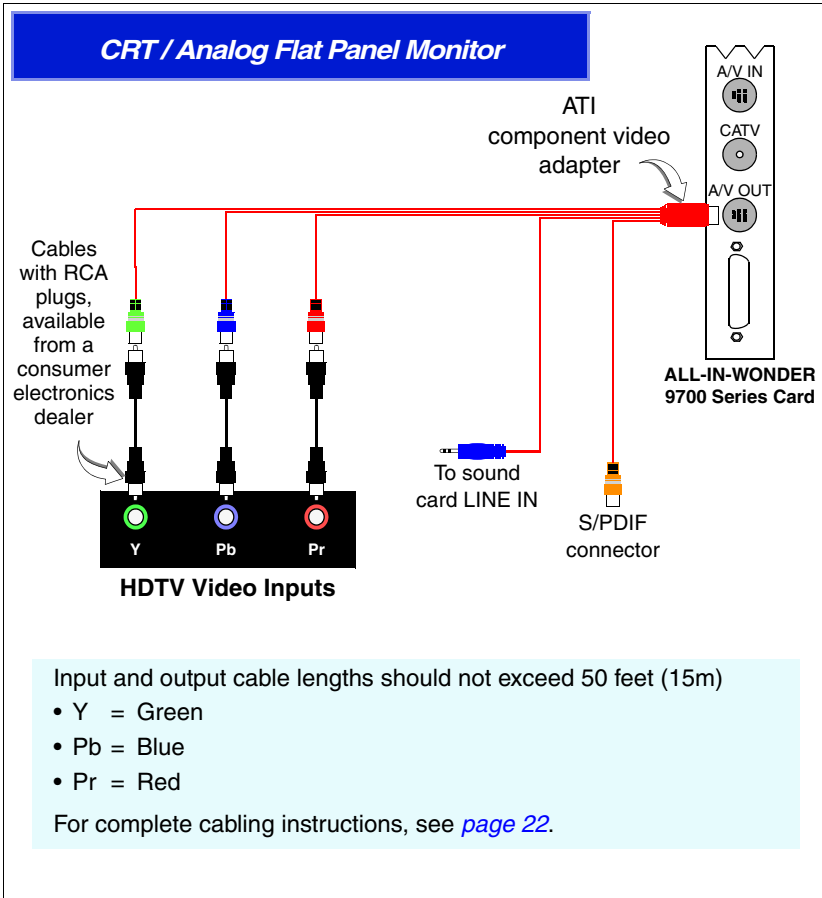

8 Turn on your component input device, and set it to YPbPr input.

See your HDTV or component input device manual for further instructions.

9 Turn on your PC.

Your TV will not display anything until Windows starts. This may take several minutes.

Using your HDTV Component Video Adapter

Use the HDTV Component Video Adapter to watch DVD movies and play video games on your High Definition Television.



Macrovision copy-protection restricts DVD playback to 480i and 480p modes.

For maximum performance when you watch DVD movies or play computer games on your HDTV, you should find the mode and screen resolution that provide the best result on your TV, and use those settings exclusively.

Windows® Control Panel Settings

Use the Windows Control Panel settings to choose the resolution and HDTV display mode.

To change settings using the Windows Control Panel

- 1** Click the Windows **Start** button, point at **Settings**, and then click **Control Panel**.
- 2** Double-click the **Display** icon, click the **Settings** tab, and use the **Screen Area** slider to select the resolution you want.
Note: If the resolution you select is not related to a timing, the system will reduce the resolution to the closest supported timing.
- 3** Click the **Advanced...** button, then click the **Displays** tab.
- 4** Click the **YPbPr** tab.
The HDTV settings page opens.
- 5** Check the modes you want in the **Custom Settings** buttons, then click **OK**.
- 6** Click the **Advanced...** button,
- 7** Click the **Adapter** tab, then click the **List All Modes...** button.

List All Modes is only available in Windows 2000 and Windows XP. It is not available in Windows 98 / 98SE, or Windows ME.

8 Click **640 x 480**.

9 For Interlaced mode, click **30Hz** or **60Hz**.

YPbPr is only available with the 30Hz or 60HZ settings.



Windows XP does not enable 640 x 480 screen resolution by default. To set 640 x 480 resolution, right-click your desktop, click **Properties**, click the **Settings** tab, click the **Advanced** button, click the **Adapter** tab, click **List all modes**, then select **640 x 480**.

- 60Hz = Progressive
- 30Hz = Interlaced

The following tips may help if you experience problems. Please contact your dealer for more advanced troubleshooting information.

Troubleshooting tips

Problem	Possible Solution
The colors on my TV display are not correct	Ensure that the connections between the Component Video Adapter and your HDTV are correct (Y=Green, Pb=Blue, Pr=Red). See the illustration on page 38 .
There is no display on my TV	Your TV will not display anything until Windows starts; this may take several minutes. <ul style="list-style-type: none"> • Set your TV to YPbPr input. • Ensure that the HDTV Component Video Adapter is properly connected, then restart your computer. • Ensure that the drivers in the ATI HTDV Component Video Adapter Kit have been installed.
DVDs will not play in 720p or 1080i modes	Macrovision copy-protection restricts DVD playback to 480i and 480p modes.
I can't see the entire display	If your component input device supports it, try 720p mode.
The display is tilted	Consult your HDTV user's manual.
My CRT display is green	Your system is in component output mode. Restart your computer with the CRT monitor connected.

CHAPTER 4

Reference

This chapter contains troubleshooting tips for your ALL-IN-WONDER card.

Troubleshooting

The following troubleshooting tips may help if you experience problems. ATI's documentation contains helpful installation/configuration tips and other valuable feature information. Please contact your dealer for more advanced troubleshooting information.

Basic troubleshooting tips

Problem	Possible Solution
No video	<ul style="list-style-type: none">• Check that the card is seated properly in its expansion slot. If the problem still exists, try a different expansion slot.• Ensure that the monitor cable is securely fastened to the card.• Make sure that the monitor and computer are plugged in and receiving power.• If necessary, disable any built-in graphics capabilities on your mother board. For more information, consult your computer's manual or manufacturer. (Note: some manufacturers do not allow the built-in graphics to be disabled or to become the secondary display.)• Make sure that you selected the appropriate monitor when you installed your enhanced driver.
Poor TV reception	<ul style="list-style-type: none">• If you use an indoor antenna, you will get the best results with an amplified model. Place it as far away from the PC monitor as possible, to avoid interference.• Splitting the cable or antenna input can reduce the signal quality. For the best reception, connect the cable or antenna directly to your card.
No sound	<ul style="list-style-type: none">• Make sure that your audio card's line input is active (see Windows® Volume Control on page 24).• Ensure that you have connected the audio cable from your ALL-IN-WONDER card to the LINE IN connector on your sound card.• Re-run the Sound Initialization Wizard:<ol style="list-style-type: none">1. Click the setup button.2. Click the Display tab.3. Click the Initialization Wizard button.4. Click Next> twice, and check the Audio Input setting.

Troubleshooting tips

For troubleshooting tips, right-click the ATI icon in the taskbar, and select **Troubleshooting**.



If you have problems during start-up, start your computer in Safe Mode.



To load Windows® in Safe Mode

- 1** Turn on your computer.
- 2** Press and hold the **CTRL** key until the Windows Startup Menu appears, then select the number for Safe Mode, and press **Enter** (on some computers, you can press F8 instead of CTRL to display the Windows® Startup Menu). In Safe Mode, open the Device Manager and check for duplicate display adapter and monitor entries if you are using only one graphics card.
 - Disable any programs that start automatically when you start Windows®.
 - Check that you have the correct monitor and display driver selected in the Display Properties. For more information, click Help in the Start menu.
 - Check for the existence of memory managers and ensure they are configured properly.
 - Refer to additional information in the Windows® README file located in the root directory on the ATI Installation CD-ROM.
- For technical assistance, refer to your technical support documentation or contact your vendor.

Audio and Video Troubleshooting

Audio problems ...

Problem	Possible Solution
<p>No Sound</p>	<p><i>Check your speakers:</i></p> <p>If you have external speakers, ensure that they are powered-on (POWER indicator light is on) and connected to the LINE-OUT or SPEAKER OUT connectors on your sound card.</p> <p>Connect the Line-In connector to your sound card first. See the illustration on page 21,</p>
<p>Still no sound?</p>	<p><i>Play a WAV sound:</i></p> <ol style="list-style-type: none"> 1 Click Start, point at Settings, select Control Panel, then double-click Sounds. 2 In the Events area, Click Asterisk, then click a WAV file in the Sound area. 3 Click the Play button  to preview the sound. <p>If you still do not hear any sound, open the Volume Control:</p> <p>Click Start, point at Programs, point at Accessories, point at Entertainment, then select Volume Control. Or, right-click the speaker icon  (usually in the lower-right corner of your screen), then click Open Volume Controls.</p> <p>If the speaker icon is not in your Taskbar, do the following:</p> <p>In the Windows Taskbar, click Start, point to Settings, click Control Panel, then double-click Multimedia. In the Audio tab, check Show volume control on the Taskbar.</p> <ul style="list-style-type: none"> • Ensure that the Volume Control and the Wave channel are not muted or set very low. <p>When you hear sound from your speakers, you know they are working.</p> <p>If you still experience audio problems, check the audio connections to your ALL-IN-WONDER card.</p>

Problem	Possible Solution
No sound from TV	Ensure that the audio connection between your ALL-IN-WONDER card and your sound card is correct. For instructions, see Input and Output Adapters on page 19.
Can't record sound	<p><i>Check the record mixer settings:</i></p> <ol style="list-style-type: none">1 Click Start, point at Programs, point at Accessories, point at Entertainment, then select Volume Control. Or, right-click the speaker icon  (usually in the lower-right corner of your screen), then click Open Volume Controls.2 In the Volume Control menu, click Options, click Properties, click Recording, then click OK. The Recording Control opens.3 Ensure that Line (or the Audio input you selected in the <i>TV Sound Initialization Wizard</i> — see page 23) is checked, then click  to close the dialog.
Can't record sound when recording from a videotape	<p><i>Connect the VCR audio output to your PC:</i></p> <p>Left and right audio output from your VCR must be connected to your ALL-IN-WONDER 9700 Series card (note that S-Video does not provide an audio connection). For instructions, see Input and Output Adapters on page 19.</p>
No sound on the videotape when outputting to a VCR	<p><i>Connect your PC audio to the VCR:</i></p> <p>Left and right audio output from your VCR must be connected to your ALL-IN-WONDER 9700 Series card (note that S-Video does not provide an audio connection). For instructions, see Input and Output Adapters on page 19.</p>

Video problems ...

<i>Problem</i>	<i>Possible Solution</i>
Video is unstable or only black and white	<p>Check that you are using the correct broadcast standard format:</p> <ul style="list-style-type: none">• For proper operation, you must specify your country in the TV Channels Initialization Wizard.• Check the quality of your incoming TV signal on another receiver; bad reception may be the cause.• Try connecting your tuner directly to the cable TV or antenna source. Too many splitters in the cable will degrade the signal.
There is no video or audio	<ul style="list-style-type: none">• Ensure that your cable or antenna is connected.• In the TV Video Settings page, ensure that the video connector is set to the correct source.• Check that the audio and video connectors are securely plugged into the correct jacks.• Check that your video card is securely seated in its slot. Please refer to the user guide for the card location.
Video recording stops unexpectedly	<ul style="list-style-type: none">• Video files are typically very large; ensure that you have sufficient disk space.• Ensure that you are recording to the correct hard disk — click the Disk Space Settings button in the Personal Video Recorder settings page.• The maximum file size for the FAT 32 file system is 4 Gigabytes. You can reduce the file size by reducing the frame size of the recording in Personal Video Recorder settings. MPEG files are usually much smaller than AVI files.• Disable screen savers while recording.• Disable Power management while recording.

<i>Problem</i>	<i>Possible Solution</i>
Dropped frames during video recording	<p>Dropped frames during video recording indicates that some part of the system is not fast enough to keep up with the recording. Recording video is a very demanding task for even the most powerful system. To achieve the best results, you must dedicate the PC to recording, and ensure that nothing else is active during recording.</p> <ul style="list-style-type: none">• Defragment your hard drive• A large, dedicated disk is recommended if you plan to do much video recording• Ensure that DMA is enabled for your hard drive, to improve disk access speed and free up the system CPU• Close all other running tasks, including those in the System Tray — clock, popup reminders, virus scanners, etc.• Close and exit from any Task Scheduler• Do not log on to your network• Do not connect USB devices while recording• Do not open or close CD-ROM trays while recording• Do not move the mouse while recording <p>MPEG recording requires a very fast CPU to encode the video.</p> <ul style="list-style-type: none">• Select I Frame Only in the Personal Video Recorder tab in Setup• Reduce the frame size of the recording <p>AVI recording creates very large file very quickly, and requires a fast hard disk system.</p> <p>Try a lower frame size, for example, 320x240. If you do not drop frames using 320x240 frame size, but frame drops do occur at larger frame sizes, your hard disk may not be fast enough.</p>

<i>Problem</i>	<i>Possible Solution</i>
Recorded video has horizontal lines around the action	<ul style="list-style-type: none">• If you are recording to AVI format, reduce the line count in the Frame Size. For example, change the frame size from 480x480 to 480x240. In the Personal Video Recorder Settings page, click the Set Custom... button, then click the Edit... button, choose your AVI preset, then edit the frame size.• If you are recording in MPEG format, ensure that Deinterlacing is checked. In the Personal Video Recorder Settings page, click the Set Custom... button, then click the Edit... button, choose your MPEG preset, then check Deinterlacing.

CD Audio Connectors

The following illustration shows the optional, internal CD audio connectors on your ALL-IN-WONDER 9700 Series card.

The CD connectors are provided for internal audio connection. The internal audio cabling (not included) must match your sound card.

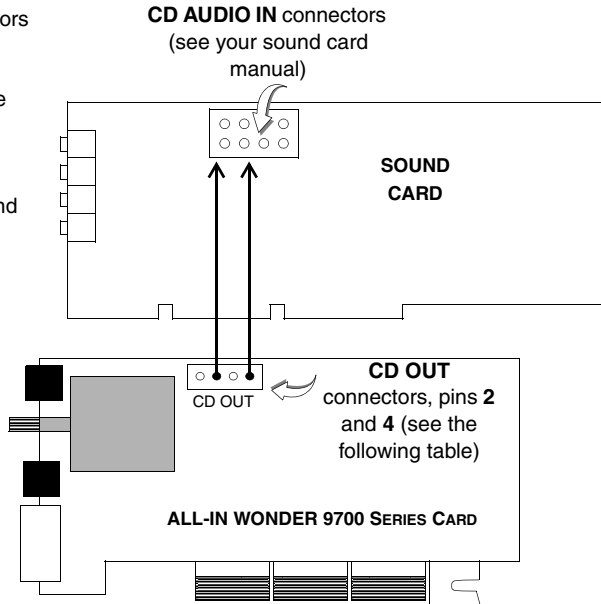

This table lists the pin assignments for the CD audio connectors on your card.

ALL-IN-WONDER 9700 Series Card	Pin	Signal
J1	Pin 1 - GND	CD OUT
J1	Pin 2 - LEFT OUT	CD OUT
J1	Pin 3 - GND	CD OUT
J1	Pin 4 - RIGHT OUT	CD OUT

Internal Audio/Video Input Header

The following illustration shows the internal audio/video input header connectors on your ALL-IN-WONDER 9700 Series card.

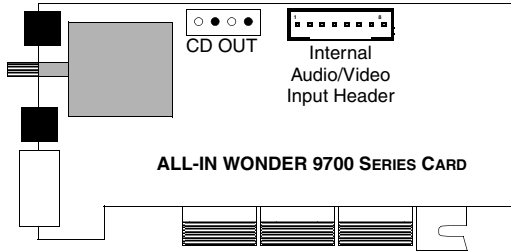

This table lists the pin assignments for the internal audio/video input header on your card.

Pin	Signal
1	CVBS / Y in
2	Video Ground
3	Luma / Pr in
4	Video Ground
5	Chroma / Pb in
6	Audio Left in
7	Audio Ground
8	Audio Right in

To Remove the ATI Multimedia Center

- 1** In the Windows[®] taskbar, click **Start**, point to **Settings**, then click **Control Panel**.
- 2** Double-click **Add/Remove Programs**.
*Windows 98 users: click the **Install/Uninstall** tab.*
- 3** Select **ATI Multimedia Center** from the list.
- 4** Click the **Change/Remove** button.
*Windows 98 users: click the **Add/Remove** button*
- 5** Click **Yes** to remove the ATI Multimedia Center.
- 6** Click **Yes** to restart your computer.

To Remove the ALL-IN-WONDER Drivers

- 1** In the Windows[®] taskbar, click **Start**, point to **Settings**, then click **Control Panel**.
- 2** Double-click **Add/Remove Programs**, then click the **Install/Uninstall** tab.
- 3** Select **ATI Display Driver** from the list.
- 4** Click the **Change/Remove** button.
*Windows 98 users: click the **Add/Remove** button.*
- 5** Click **Yes** to remove the ALL-IN-WONDER 9700 Series card driver.
- 6** Click **Yes** to restart your computer.

Compliance Information

FCC Compliance Information

The ALL-IN-WONDER 9700 Series of cards complies with FCC Rules Part 15. Operation is subject to the following two conditions

- This device may not cause harmful interference, and
- This device must accept any interference received, including interference that may cause undesired operation.

This equipment has been tested and found to comply with the limits for a Class B digital device, pursuant to Part 15 of the FCC Rules. These limits are designed to provide reasonable protection against harmful interference in a residential installation. This equipment generates, uses and can radiate radio frequency energy and, if not installed and used in accordance with manufacturer's instructions, may cause harmful interference to radio communications. However, there is no guarantee that interference will not occur in a particular installation. If this equipment does cause harmful interference to radio or television reception, which can be determined by turning the equipment off and on, the user is encouraged to try to correct the interference by one or more of the following measures:

- Re-orient or relocate the receiving antenna.
 - Increase the separation between the equipment and receiver.
 - Connect the equipment to an outlet on a circuit different from that to which the receiver is connected.
 - Consult the dealer or an experienced radio/TV technician for help.
- The use of shielded cables for connection of the monitor to the graphics card is required to ensure compliance with FCC regulations.
 - Changes or modifications to this unit not expressly approved by the party responsible for compliance could void the user's authority to operate this equipment.

Industry Canada Compliance Statement

ICES-003 This Class B digital apparatus complies with Canadian ICES=003.

Cet appareil numérique de la Classe B est conforme à la norme NMB-003 du Canada.

For further compliance information:

ATI Research Inc.
4 Mount Royal Ave.
Marlborough, MA
01752-1976
USA
508-303-3900

CE Compliance Information

EMC Directive 89/336/EEC and Amendment 92/31/EEC, Class B Digital Device

EN 50081-1, Generic Emissions Standard for Residential, Commercial and Light Industrial Products

(EN 55022/CISPR 22, Limits and Methods of Measurement of Radio Interference Characteristics Information Technology Equipment) *Warning: This is a Class B product. In a domestic environment this product may cause radio interference in which case the user may be required to take adequate measures.*

EN 50082-1, Generic Immunity Standard for Residential, Commercial and Light Industrial Products

(IEC 801-2, IEC 801-3, IEC 801-4) Directive EMC 89/336/CEE et amendement 92/31/CEE, dispositif numérique de Classe B

EN 50081-1, Norme sur les émissions génériques pour les produits domestiques, commerciaux et industriels légers

(EN 55022/CISPR 22, Limites et méthodes de mesure des caractéristiques d'interférences radiophoniques, Matériel des technologies de l'information) *Mise en garde: ceci est un produit de Classe B. Il risque produire des interférences radiophoniques dans un environnement domestique auquel cas l'utilisateur peut se voir demandé de prendre des mesures adéquates.*

EN 50082-1, Norme sur l'immunité générique pour produits domestiques, commerciaux et industriels légers.

(CEI 801-2, CEI 801-3, CEI 801-4)

EMC Richtlinie 89/336/EEC und Änderung 92/31/EEC, Digitales Gerät der Klasse B

EN 50081-1, Allgemeiner Emissions-Standard für Haushalt- und kommerzielle Produkte sowie Erzeugnisse der Leichtindustrie

(EN 55022/CISPR 22, Beschränkungen und Verfahren der Messung von informationstechnischen Ausrüstungen mit Funkstörmerkmalen) *Warnung: Dies ist ein Erzeugnis der Klasse B. Dieses Erzeugnis kann Funkstörungen im Wohnbereich verursachen; in diesem Fall können entsprechende Maßnahmen seitens des Benutzers erforderlich sein.*

EN 50082-1, Allgemeiner Unempfindlichkeits-Standard für Haushalt- und kommerzielle Produkte sowie Erzeugnisse der Leichtindustrie

(IEC 801-2, IEC 801-3, IEC 801-4)

Index

A

Adapters

input and output 19

ATI Multimedia Center

uninstalling 53

User's Guide 4

ATI REMOTE WONDER 15

Audio connectors

CD 51

Audio troubleshooting 46

C

CATALYST software suite

installing 14

CD audio connectors 51

Color depth

increasing 17

Colors

increasing number of 17

Composite video 20

Control panel settings 39

D

Displaying PC output on TV 21

Drivers

downloaded from ATI website 18

removing 53

G

GART driver 9

H

HDTV

displaying PC output on 22

HDTV Component Video Adapter

35

Hydravision 3

I

Input and output adapters 19

displaying PC output on high definition TV 22

displaying PC output on TV and recording on videotape 21

watching movies on your PC and recording video 20

Installing the hardware and software 9

input and output adapters 19

Installing your card 11

Internal audio/video input header 52

L

LaunchPad 18

M

Monitor

adjusting display 30

using a monitor vs. TV display 29

Multimedia Center

starting 18

Multiple display support 16

multView 33

audio requirements 34

Picture in Picture, Picture outside

Picture 33

TV WONDER 33

O

Online Help 4

P

Picture in Picture 33

Picture outside Picture 33

Power requirements 12

R

Recording PC output on videotape

21

Recording Video 20

Remote control 15

Removing drivers 53

S

Safe Mode

 Loading Windows in 45

SCART connectors 28

Setting up your HDTV Component

Video Adapter 36

Sound card connector

 selecting for TV audio input 23

S-Video 20

System requirements 3, 36

T

Troubleshooting 45

 audio and video 46

 basic 44

Troubleshooting tips 16, 43

TV

 attaching to your card 26

 changing display configurations 32

 displaying PC output on 21

 multView 33

 reception tips 30

 reducing edge distortion 31

 selecting sound card connector for

 TV audio input 23

 using games and applications 32

 viewing text on 30

TV Out

 enabling, using, adjusting 29

TV WONDER 33

U

Uninstalling old graphics card software 10

Using your HDTV Component

Video Adapter 39

V

Video

 composite video, S-Video, S-VHS
 25

Video troubleshooting 46

Volume control 24

W

Warranty

 customer service 5

 hardware 6

 HDTV Component Video Output

 Adapter 36

 limitations 7

 registration 5

 service 6

Watching movies on your PC and recording video 20

Windows volume control 24

Windows XP 40