



INSTALLATION GUIDE FOR THE VGA-CMP



INTRODUCTION

The VPI VGA-CMP converts VGA video to component video.

INSTALLATION

1. Turn OFF power to video source and video display device.
2. Connect a VEXT-3-MM VGA video cable (sold separately) from the video source to the female connector labeled "VGA" on the VGA-CMP.
3. Connect a set of CMPEXT-3-MM 75 ohm RCA cables (sold separately) between the "Y", "Pb", and "Pr" connectors on the VGA-CMP and the like connectors on the video display device. Typically the "Y" connector is green, the "Pb" connector is blue, and the "Pr" connector is red.
4. Plug in the AC adapter and connect it to the VGA-CMP.
5. Turn ON power to the video source and video display device.

Note: Additional video cable lengths (VEXT-6/10/15/25/35/50/75/100-MM and CMPEXT-6/12/25/50/75/100-MM) may be ordered from Video Products Inc by calling (800) 626--7801 (U.S) or 330-562-2622 or visit our website at www.vpi.us

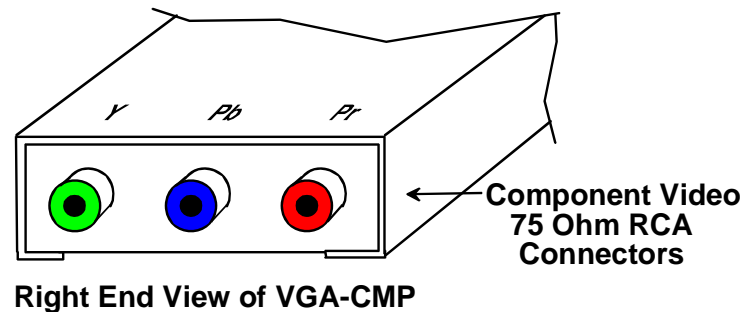
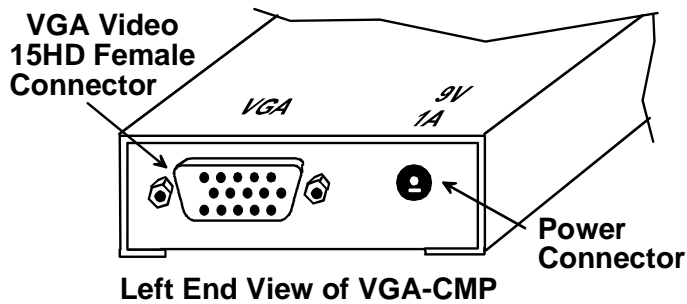
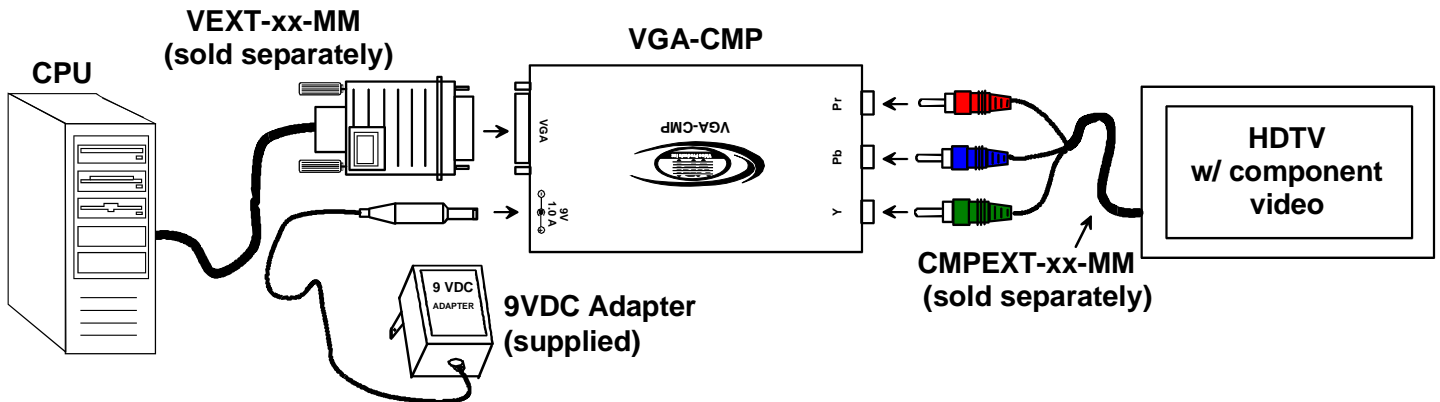

TROUBLESHOOTING

Problem	Solution
No Video	<ul style="list-style-type: none">• Connect power to VGA-CMP• Make sure cable connections are secure and in their appropriate places

TECHNICAL SPECIFICATIONS

General

Description	Specification
Input Signal Type	VGA, SVGA, XGA
Input Signal Connector	15HD Female
Output Signal Type	High Definition Component Video
Output Connectors	75 ohm RCA Female
Max. Input Levels	.7vp-p
Max. Output Levels	1vp-p
Input / Output Impedance	75 Ohms
Maximum Resolution	1920 x 1080
Power	110 or 220VAC at 50 or 60 Hz-9VDC/ 1A AC adapter
Size (In.) W x D x H	3.7 x 2.1 x 1.15

COPYRIGHT

© 2006 Video Products Inc. All rights reserved. No part of this publication may be reproduced, stored in a retrieval system, or transmitted in any form or by any means, electronic, mechanical, photocopying, recording, or otherwise, without the prior written consent of Video Products Inc, 1275 Danner Drive • Aurora, OH 44202.

CHANGES

The material in this guide is for information only and is subject to change without notice. Video Products Inc reserves the right to make changes in the product design without reservation and without notification to its users.

WARRANTY INFORMATION

The warranty period on this product (parts and labor) is one (1) year from date of purchase. Please contact Video Products Inc at (800) 626-7801 or 330-562-2622 for information regarding repairs and/or returns. A return authorization number is required for all repairs/returns.

MODEL NO: VGA-CMP

SERIAL NO: _____

DATE: _____

INSPECTED BY: _____