



INSTRUCTIONS AND MAINTENANCE MANUAL



PACR9S PORTABLE AIR CONDITIONER

WINDCHASER PRODUCTS • ENGLISH

Thank you for choosing WINDCHASER PRODUCTS. We hope this product will give you complete satisfaction. If however a problem occurs, please contact your dealer or our customer service department.

READ AND KEEP INSTRUCTIONS

CONTENTS

VERY IMPORTANT.....	1
TO SAVE ENERGY.....	1
TECHNICAL SPECIFICATIONS.....	1
LEARN INTELLIGENT AIR-CONDITIONING.....	2
SAFETY INSTRUCTIONS.....	2
PARTS ILLUSTRATION.....	3
INSTALLATION.....	5
OPERATING.....	6
VENTILATION ONLY.....	6
AIR CONDITIONING.....	6
TIMER PROGRAMMING.....	7
DEHUMIDIFICATION OPERATION.....	7
FAHRENHEIT & CELSIUS DISPLAY BUTTON.....	8
DRAINING EXCESS CONDENSATE WATER.....	8
CLEANING THE APPLIANCE.....	9
LONG TERM STORAGE.....	9
TROUBLESHOOTING GUIDE.....	10
PRODUCT LIMITED WARRANTY.....	11

SAFETY POWER SUPPLY CORD

This unit is provided with a Leakage Current Detection and Interruption circuit (LCDI) built into the plug of the power supply cord. This device provides protection to reduce the risk of fire due to arcing faults in the power-supply cord. Each time before using the Room Air Conditioner, follow the "Plug Testing Instructions" given below to ensure that the LCDI circuit is functioning properly.

PLUG TESTING INSTRUCTIONS:

1. PRESS TEST BUTTON. UNIT SHOULD TRIP.
2. PRESS RESET BUTTON FOR USE.

DO NOT USE IF ABOVE TEST FAILS.

The conductors inside this power supply cord are surrounded by shields which monitor the leakage current. These shields are not grounded. Periodically examine the cord for any damage. If the shield gets exposed, immediately unplug the power supply cord and do not use the unit.

Do not repair a damaged cord. Replace the damaged cord only with a new replacement power supply cord obtained from the manufacturer.

In the event the LCDI Plug of the power supply cord trips by itself, then first examine the cord for any damage. If there is no damage to the cord then press the RESET Button. If the LCDI Plug trips again, then immediately unplug the power supply cord. Replace the damaged cord with a new replacement power supply cord.

To obtain a new replacement power supply cord contact WindChaser Products Customer Service at: (800) 405-2943 x102 or e-mail at: customerservice@windchaserproducts.com.

Do not use The TEST and RESET Buttons as an on / off switch. They are only meant to be used to periodically check the LCDI plug.

VERY IMPORTANT

Do not install and use your air conditioner before **completely reading these instructions**. This will help you optimize the operation of your air conditioner. Make sure that you haven't lost the **little box placed on the top of the appliance** itself. It contains **all accessories, which are essential for use**.

The following advice and instructions should be followed closely:

1. The unit must always be used in an upright position as it contains a cooling agent.
2. After unpacking, **place** the appliance **upright** to allow the cooling agent to stabilize, and wait 3 hours before use.

Failure to comply with these instructions may damage the upright appliance and would **invalidate the WINDCHASER guarantee**.

Using the unit in wine cellars or in any room with a temperature **under 61°F is not recommended**.

TO SAVE ENERGY

- Blocking of the filter reduces the efficiency of the air and increases its power consumption by up to 6%.
- Avoid opening doors frequently.
- Each person present in a room provides between 100 W and 150 W of heat output. Consequently, the more people there are in a room, the less successful the appliance will be in cooling.

TECHNICAL SPECIFICATIONS

VOLTAGE / FREQUENCY	115V / 60Hz
POWER INPUT	900 W
COOLING CAPACITY	9000 BTU./H
MOISTURE REMOVAL	3.4 Pints / Hour (38.6 Liters / Day)
COOLANT	R-22
TIMER	12 Hours
AIR FLOW VOLUME	188 CFM (Cubic Feet / Minute)
THERMOSTAT	61° - 90°F (16° - 32°C)
DIMENSIONS (W x H x D)	18.1" x 30.7" x 12.6"
Weight Net (Gross)	76 lbs. / 34.5 kgs (86 lbs. / 39 kgs)

LEARN INTELLIGENT AIR-CONDITIONING

The unit is electronically controlled which allows precise programming to adjust room temperature.

Air conditioning does not mean, “cooling down too much!” The use of an air conditioner allows you to have a pleasant atmosphere by reducing the temperature. This air conditioner allows you to control the 4 factors that determine optimal comfort in a room.

- **Humidity Rate:** the humidity in a room also causes a sensation of stifling heat in the summer. The air conditioner not only cools down the temperature but also dehumidifies the air.
- **Temperature:** the main function of an air conditioner is to draw hot air out of the room.
- **Air purity:** thanks to the air filter, the unit removes the dust particles creating a healthier room atmosphere.
- **Airflow:** The air conditioner regulates the air flow, allowing the flow to be directed and ensuring optimal air circulation.

****Note:** Avoid being in a cold air flow, and do not direct it onto people. To ensure the optimal efficiency of the appliance, we advise you to keep doors and windows closed, and to take in account the surface of the walls and windows exposed to the sun. In this case, in order to optimize the functioning of your air conditioner, we recommend partially closing the window coverings.

SAFETY INSTRUCTIONS

- Do not damage the power cord.
- Never lay down the appliance while it is working.
- Always keep it in an upright position to avoid any damage in the cooling system.
- Never splash water on the appliance's cabinet or on the control panel.
- Be sure that the air inlets and outlets are not blocked or covered up.
- Never place anything on top of the unit and do not cover it with any kind of cloth while it is plugged in or in-use.
- The air conditioner has been designed to be used only in a house, office and similar conditions and it should not be used for any other purpose.
- Never connect the appliance to a defective socket.
- Plug the appliance in a properly grounded dedicated 15 amp socket. Check your breaker box to determine which circuit the socket is on.
- Make sure that the appliance is correctly connected before switching it on.
- Never unplug the air conditioner while it is working. This could damage the electronic circuits.
- To turn on the unit, always use the switch on the control panel.
- Do not bend or crush the warm air exhaust hose.
- It is dangerous to modify or to change the characteristics of the appliance.
- Prevent children from climbing on the appliance.
- Do not place the air conditioner near curtains (**minimum distance 1.5 ft.**).
- Do not place the power cord under a carpet.
- Never install the appliance in direct sunshine or in the rain.
- When used for the first time, and every time it is turned on, it takes the unit about 3 minutes to be operational.
- Keep the area around the warm air outlet sufficiently clean and make sure that it is not congested.
- For any repairs, **refer directly** to our **customer service department**. Repairs carried out by unqualified people may cause damage or may even be dangerous and void the warranty.

Any damage resulting from failure to comply with these instructions is excluded from the warranty.

PARTS ILLUSTRATION

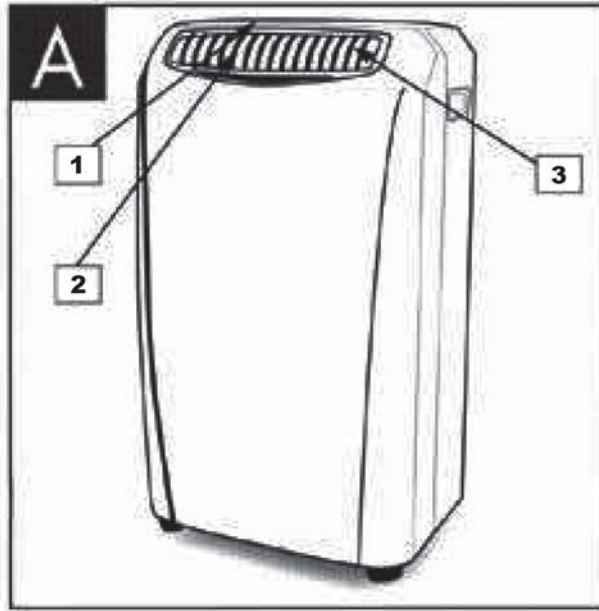

Figure A - Front View

- 1) Control Panel
- 2) Cold air Outlet
- 3) Louvers

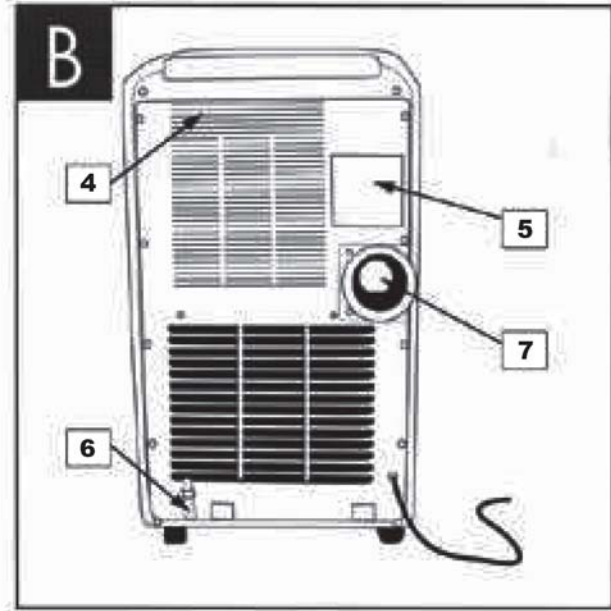

Figure B - Rear View

- 4) Air Filter
- 5) Rating Plate
- 6) Condensate Drain Hole
- 7) Warm Air Outlet

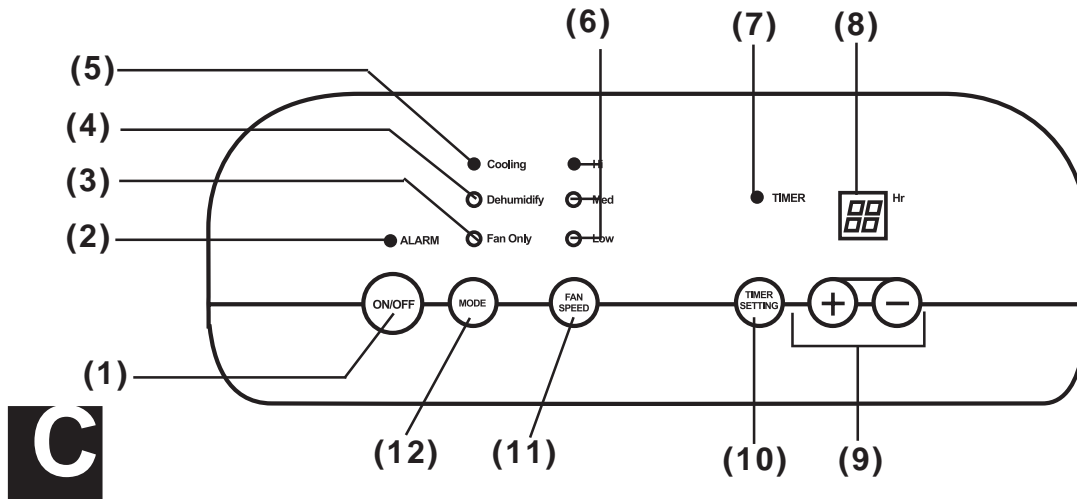

Figure C - Control Panel

- 1) Power ON/OFF Button
- 2) Alarm Indicator Light
- 3) Fan ON/OFF Indicator Light
- 4) Dehumidifier ON/OFF Indicator Light
- 5) AC ON/OFF Indicator Light
- 6) AC Fan Speed Indicator Lights
- 7) Timer ON/OFF Indicator Light
- 8) Thermostat and Timer Display Panel
- 9) Thermostat and Timer Adjustment Buttons
- 10) Timer ON/OFF Button
- 11) AC Fan Speed Button
- 12) Mode Button

This air conditioner is a perfectly mobile self-contained appliance. All the components are located inside the appliance. It is supplied with various accessories:

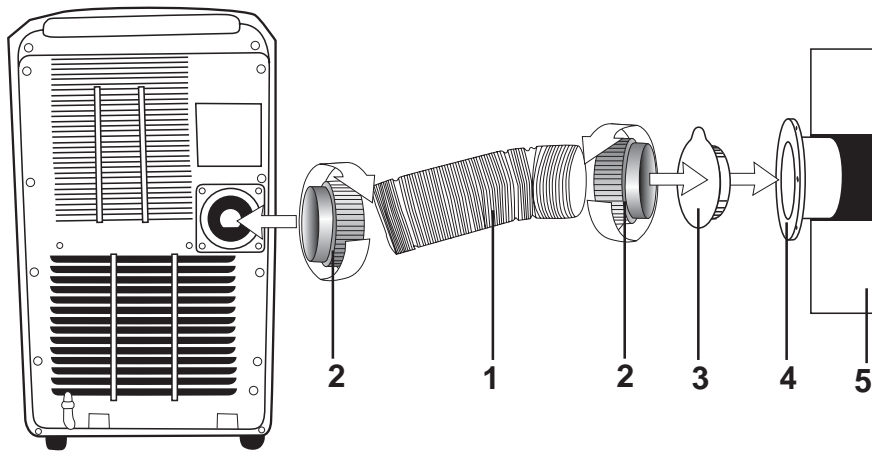
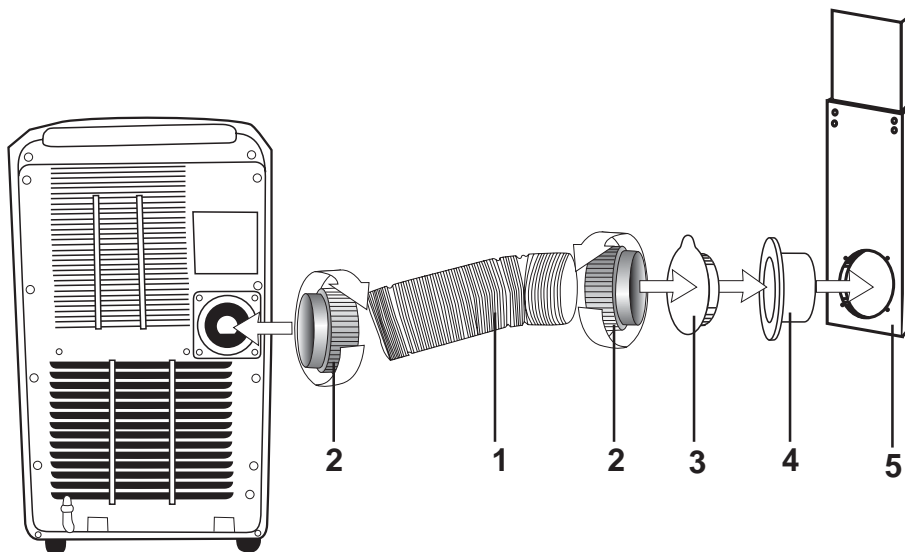

Figure D - Accessories for Venting through a Wall

- | | |
|---------------------------|-------------------|
| 1) Exhaust Hose | 4) Nozzle Fitting |
| 2) Exhaust Hose Connector | 5) Wall |
| 3) Nozzle Fitting Cover | |



Adjustable Window Panel



Figure D - Accessories for Venting through a Window

- | | |
|---------------------------|----------------------------|
| 1) Exhaust Hose | 4) Nozzle Fitting |
| 2) Exhaust Hose Connector | 5) Adjustable Window Panel |
| 3) Nozzle Fitting Cover | |

*If you need to extend your exhaust hose, it may be extended up to 5' only using 4" P.V.C. pipe available at your local hardware store. **DO NOT USE DRYER TYPE EXHAUST HOSE TO LENGTHEN. ..EXHAUST.***

INSTALLATION

Install the appliance in the room to be air-conditioned. It must be positioned on a flat surface. If the appliance has been transported lying down, put it in the vertical position and leave it for 3 hours so that the coolant “stabilizes”.



- 1) Check the installation of the air filter.
- 2) Install the exhaust hose connector (2, Fig. D) on the warm air outlet (at the back of the appliance), and turn it clockwise.
- 3) Connect the exhaust hose (1, Fig. D) to the connector turning it counterclockwise and pull the hose to the desired length.
- 4) Place the second connector (2, Fig. D) on the opposite end of the hose, turning it counterclockwise.
- 5) Drill a 4” diameter hole into a wall **or** install the plastic window panel in the window and adjust it's length.
- 6) Install nozzle fitting (3, Fig. D) into the hole in the wall or attach the nozzle fitting (3, Fig. D) to the plastic window panel with four screws.
- 7) Connect the exhaust hose connector (2, Fig. D) into the nozzle fitting (3, Fig. D).
- 8) The cover (4, Fig. D) needs to be installed on the nozzle fitting (3, Fig. D) when the appliance is not used.

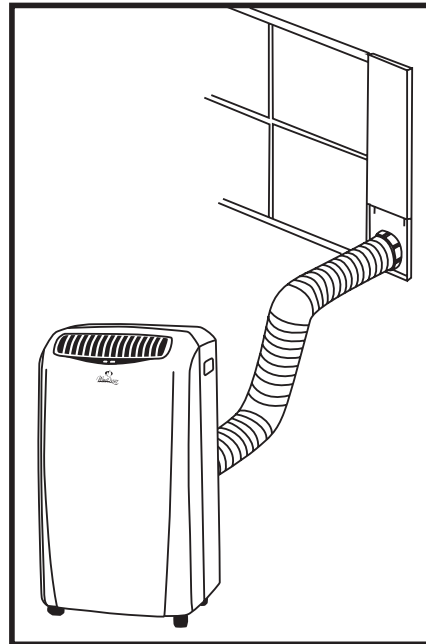
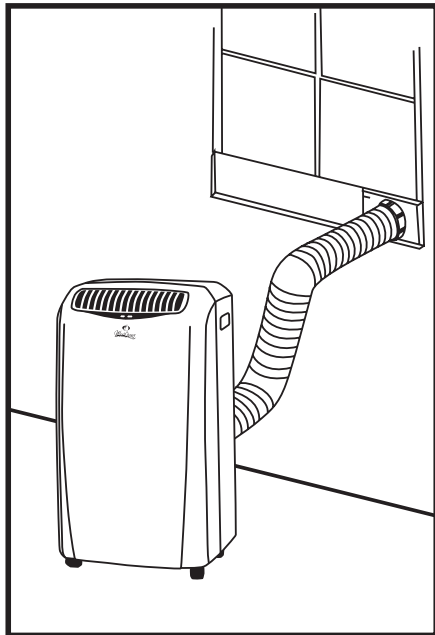

For ceiling installation make sure there is adequate ventilation and airflow. The exhaust hose must clear the surrounding insulation.

The air conditioner can now be connected to a **110V/60 Hz dedicated 15 amp socket**.

You are advised not to use an extension cord. If, however, this is unavoidable, the cord must be 14 gauge, grounded at both ends and not be more than 30 feet long.

**** Note: Make sure the unit is plugged into a “dedicated” circuit; this unit requires 12 amps of power every time it is started.**

OPERATING

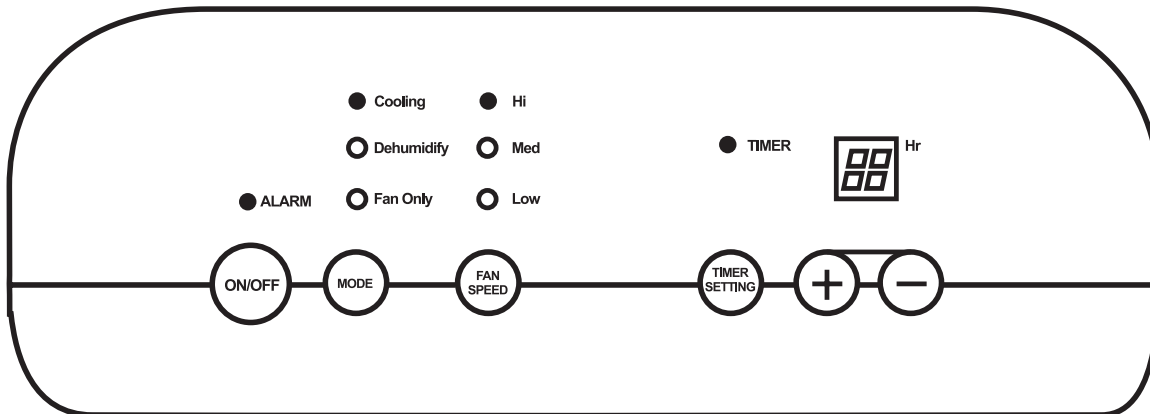

The compressor is an essential component of the appliance for producing cold air. This appliance is fitted with a thermal protection device which allows the compressor to be started only after a time delay of three minutes.

STARTING YOUR NEW WINDCHASER PRODUCTS PACE9

Ventilation Only ☼

1. Press the ON/OFF Button to turn on the unit.
2. Press the Mode Button to select fan.
3. Select Low, Medium or High Speed by pressing the fan speed button.

Air Conditioning ☼

1. Press the ON/OFF Button to turn on the unit.
2. Press the "MODE" button to select a mode function (Fan, Cooling or Dehumidifier).
3. Select Low, Medium or High Speed by pressing the fan speed button.
4. Use the (+) and (-) Thermostat buttons to set the desired thermostat temperature.
5. The appliance will stop air conditioning once the selected temperature has been reached. It will then continue to ventilate. Once the room temperature has exceeded the selected temperature, the unit will begin to air condition again.

Adjust the direction of the airflow by directing the louvers (3, Fig. A).

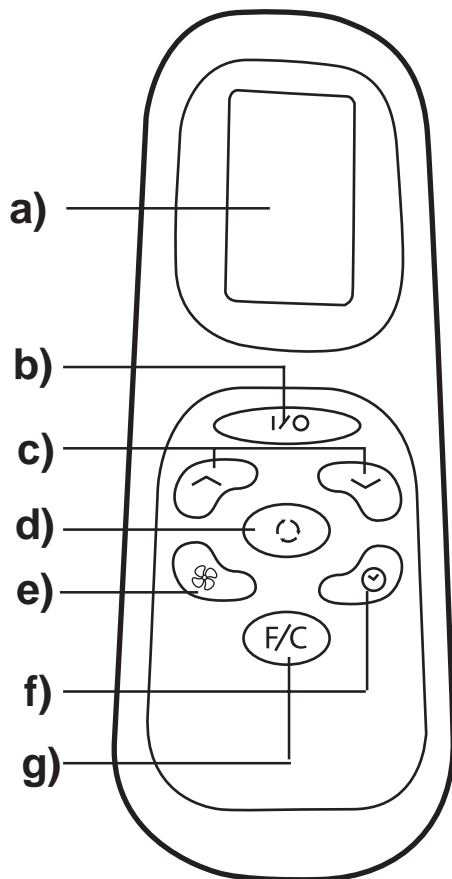

- a) LCD Screen
- b) Power ON/OFF Button
- c) Timer and Thermostat Setting Buttons
- d) Mode Button
(Select A/C, Fan or Dehumidifier)
- e) A/C Fan Speed Button
(High, Medium or Low)
- f) Timer ON/OFF Button
- g) Fahrenheit / Celcius Selector

TIMER PROGRAMMING

1. To set the Shut-Off Timer on the unit, make sure the unit is on, then press the TIMER SETTING button on the control panel or the (⌚) button on the remote control .
2. Press the (↗) button on the remote or the (+) button on the control panel to set the desired time. If the setting is higher than desired, press the (↘) on the remote control or the (-) on the control panel to lower the time.
3. Finally press the (⌚) button on the remote or the "TIME SETING" button on the control panel to enter the selected off time to finalize the setting.
4. To activate the ON Timer, follow the instructions above, but the unit must be turned off first.

DEHUMIDIFICATION OPERATION

Press the "MODE" button on the control panel or (☁) button on the remote to select the dehumidifier mode. When the dehumidifier mode is on, the temperature buttons and the fan speed buttons do not function and the fan will operate on low speed. The dehumidifier indicator light will illuminate and stay solid while the unit is dehumidifying. When the humidity in the room is 50% or lower, the compressor will not run, the unit will not dehumidify, and the dehumidifier light will blink. Remember, the exhaust hose does not need to be used in dehumidifier mode.

FAHRENHEIT AND CELSIUS DISPLAY BUTTON

The temperature readings can be switched between fahrenheit and celsius by pressing the F/C button on the remote. When the remote control is turned on for the first time, fahrenheit will be displayed first. Pressing the F/C button will then display the temperature in celsius. To return the temperature display back to fahrenheit, press the F/C button again.

DRAINING EXCESS CONDENSATE WATER

While air conditioning, the unit automatically dehumidifies the air in the room. The water from dehumidification is stored in a collecting tank and then immediately “evaporated” and evacuated via the warm air outlet duct. However, when it is extremely humid, the collecting tank may fill up. In this case, the Alarm Indicator Light (2, Fig. C) turns on and the air conditioner switches itself off.

It is then necessary to drain the water through the condensate drain hose (6, Fig. B).

- Place the drain hose (6) above an empty container
- Remove the plug and to let the water run out (the capacity of the collecting tank is about 1.5 pts).
- Refit the plug and put the condensation drain hose back in its original position.

CLEANING THE APPLIANCE

Before cleaning and maintenance, turn off and unplug the unit. For safety reasons, never wash the air conditioner.

EXTERIOR SURFACES OF THE APPLIANCE

- Clean the air conditioner by using a **damp sponge**, and dry it with a clean cloth afterwards.
- Never use alcohol or any product containing solvents.

AIR FILTER

The air filter collects dust contained in the air. To keep the dust from clogging the appliance, the unit must always be used with its air filter.

- The build up of dust reduces the efficiency of the air conditioner, therefore, the air filter must be cleaned every two weeks, and more often if the machine operates in a dusty atmosphere.
- If the filter is obstructed, the air conditioner will be less efficient.
- Remove the air filter with the appliance switched off, by pulling upward on the tab.
- Never use hot or soapy water.
- Clean the filter with a vacuum cleaner. If the filter is very dirty, you can wash it in warm water. Make sure that the air filter is completely dry before putting it back.
- Do not bend the filter.

LONG TERM STORAGE

When the season has ended or when you plan not to use the unit, we recommend the following procedure to be taken:

- Drain excess water from the pan.
- Run the unit for 3 or 4 hours in fan mode. This will thoroughly dry the inside of the unit.
- Disconnect the appliance and wrap power cord and plug.
- Clean the appliance and store it, protecting it from dust.
- Store the appliance in an upright position. Keep it in a cool / dry place and away from sunshine.

TROUBLESHOOTING GUIDE

When the air conditioner does not work, it is sometimes a minor problem which the user can handle. Before calling customer service, you should check the following points and see if you can solve the problem by yourself.

Problem	Probable Causes	Solutions
The air conditioner does not work.	<ol style="list-style-type: none">1) Plug not properly inserted into wall socket.2) Insufficient amount of amperage to start unit.3) Water tank is full / alarm light illuminated.	<ol style="list-style-type: none">1) Plug the appliance in properly.2) Check circuit board for 15-20 amp fuse availability.3) Empty the water tank.
Poor performance.	<ol style="list-style-type: none">1) 3 minute temporizing.2) Wrong selection of operating function.3) Air filter obstructed by dust.4) Warm air outlet duct is squashed or obstructed.	<ol style="list-style-type: none">1) Wait 3 minutes.2) Select correct operating function.3) Clean air filter.4) Assure proper running of the duct.
Noisy.	The unit is on an uneven surface and is vibrating.	Place the unit on a flat surface.
The air conditioner makes a bubbling noise.	The cooling agent is circulating through the circuits.	This is normal.

PRODUCT LIMITED WARRANTY

This Warranty applies to new Product only and excludes optional accessories and attachments. Extended Compressor Warranty applies only to Product with manufacturing dates beginning January 1, 1998.

During the first year from date of original purchase WINDCHASER Products are warranted to be free from defects in materials or workmanship under normal use, service and maintenance. During the 2nd through 5th years from date of original purchase WINDCHASER warrants the compressor (part only) against defects in material or workmanship under normal use, service and maintenance.

This Warranty applies to the original purchaser subject to the following terms and conditions:

WHAT IS COVERED: Product's components as originally affixed by the manufacturer there of are defective in materials or workmanship under normal use, service and maintenance.

WHAT IS NOT COVERED BY THIS WARRANTY: This Warranty does not extend to or cover:

- (1) Any defect due to the negligence of others; failure to install, operate or maintain unit or accessories and attachments in accordance with installation instructions (operating, installation and maintenance manual and instructions are furnished with each new unit); unreasonable use; accidents; alteration, use of unauthorized or non-standardized WINDCHASER parts, accessories and attachments; acts of God; theft; vandalism; blown fuses; electrical malfunction. (i.e., resulting from power surges, shorted or overloaded circuits, outlets or electrical utility power quality, etc.), incorrect installation; use of any power source other than that specified on the Product's specification label; or repair by anyone other than a service facility specified by an authorized WINDCHASER representative.
- (2) Diagnostic, troubleshooting and travel costs.
- (3) Operation and usage orientation costs.
- (4) Performance or operation certification and testing costs.
- (5) Normal wear and tear of parts including but not limited to, hoses, cables, accessories and attachments.
- (6) Shipping, handling, packaging and delivery costs of the product, parts or accessories.
- (7) Shipping, handling and freight damages.
- (8) Diagnosing, repairing, removing, installing, shipping, servicing and/ or handling costs of either defective parts or replacement parts as relating to Extended 4 Year Compressor Warranty.

WHO IS COVERED: The original purchaser from the retailer.

WHAT WE WILL DO: During the first year WINDCHASER will either repair or replace, at its option, all defective Product components free of charge that are covered by this Limited Warranty on a carry-in basis to the authorized WINDCHASER repair station. During the second through fifth years WINDCHASER at its option, will provide a new or refurbished compressor (part only) free of charge as covered by this Limited Warranty on a carry-in basis to the authorized WINDCHASER repair station.

WHAT YOU MUST DO FOR WARRANTY SERVICE: You must return the defective Product to your authorized WINDCHASER repair station along with a copy of bill of sale or credit card charge receipt or other document evidencing the date of original purchase and Product's model and serial number.

NOTE :

- Before returning the Product; call your WINDCHASER dealer or distributor that sold you the Product for instructions and details regarding their return merchandise policies.
- Do not return Product, components or parts to WINDCHASER without prior written approval and Return Authorization from WINDCHASER.
- You are responsible for prepaying all shipping, handling, packaging and delivery costs to and from the warranty repair center and or factory.
- WINDCHASER, its dealers, distributors and representatives cannot be responsible for damage resulting from improper packing and or mishandling by shipper.

THE FOREGOING EXPRESSES ALL OF WINDCHASER'S OBLIGATIONS AND LIABILITIES WITH RESPECT TO THE QUALITY OF PRODUCT, ITS COMPONENTS, ACCESSORIES AND ATTACHMENTS FURNISHED BY IT. ALL OTHER WARRANTIES, EXPRESS OR IMPLIED, INCLUDING THE WARRANTIES. TIES OF MERCHANTABILITY OR FITNESS FOR A PARTICULAR PURPOSE ARE DISCLAIMED. WINDCHASER SHALL NOT BE LIABLE FOR THE LOSS OF USE OF THE PRODUCT, ITS COMPONENTS, ACCESSORIES AND ATTACHMENTS, INCONVENIENCE, LOSS OR ANY OTHER DAMAGES, DIRECT OR CONSEQUENTIAL ARISING OUT OF THE USE OF, OR INABILITY TO USE THE PRODUCT ITS COMPONENTS AND ACCESSORIES OR DAMAGES RESULTING FROM OR ATTRIBUTABLE TO DEFECTS IN THE PRODUCT, ITS COMPONENTS AND ACCESSORIES.

NO ONE OTHER THAN WINDCHASER HAS AUTHORITY TO EXTEND OR MODIFY THE TERMS OF THIS LIMITED WARRANTY IN ANY MANNER WHATSOEVER.

Some states do not allow that exclusion or limitation of incidental or consequential damages or limitations on how long an implied warranty lasts so these limitations or exclusions may not apply to you. This Limited Warranty gives you certain legal rights and you may also have other rights specific to your country, state or province. This warranty is only valid in the United States and Canada.

For further information call:



**WINDCHASER PORTABLE AIR CONDITIONERS
CUSTOMER RELATIONS INFORMATION
TOLL FREE 800-405-2943**