

SANYO INSTALLATION INSTRUCTIONS

RCS-KS2432AWD

■ Parts supplied with remote controller

See Table 1.

■ Remote controller installation guidelines

Installation location

- Mount the remote controller 1 to 1.5 meters off the floor where it can sense the average temperature of the room.
- Do not mount the remote controller in a place exposed to direct sunlight or where it is exposed to outside air such as near a window.
- Do not mount the remote controller behind a curtain or other object so that it is separated from the air circulation of the room.
- Mount the remote controller inside the room being air conditioned.
- The remote controller should be mounted on a wall or other surface vertically.

Switching the room temperature sensor

Room temperature sensors are separately incorporated in both the indoor unit and the remote controller. Either sensor can be used to sense the room temperature. The indoor unit sensor is usually used.

If you wish the remote controller to sense the room temperature, press the SENSOR button with a ballpoint pen or tool with a small tip.

■ How to install the remote controller

- <NOTE 1> Do not twist the remote controller wire with the power cord, or run them in the same metal conduit, because this may cause a malfunction.
- <NOTE 2> Install the remote controller away from all sources of electrical noise.
- <NOTE 3> Install a noise filter or take other appropriate action if electrical noise affects the power supply circuit of the unit.
- Use an electric junction box (supplied locally) for embedded mounting of the remote controller. (See Fig. 1)

Table 1

No.	Supplied parts	Q'ty	No.	Supplied parts	Q'ty
①	Remote controller (comes with 200mm wire)	1	⑤	Wire joints	6
②	Machine screws M4 × 25	2	⑥	Harness	1
③	Tapping screws M4 × 25	2	⑦	Clamper	1
④	Spacers	2	⑧	Instruction manual	1

Note: Remote controller model name RCS-KS2432AWD
Code: 851-0-0054-590-00-0

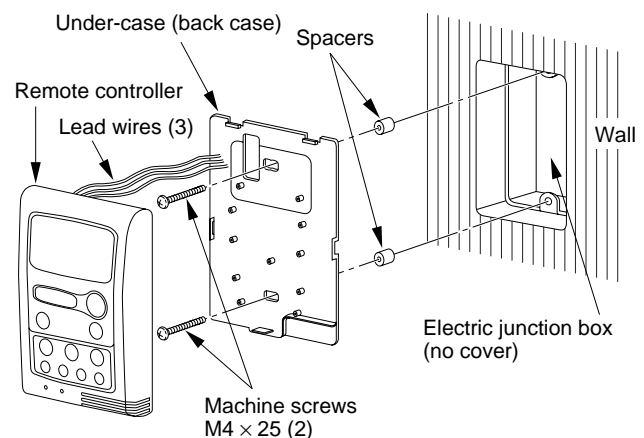

Fig. 1

- For surface mounting on the wall, see Fig. 2.
1. Insert a screwdriver or the like in the groove on the lower side of the remote controller to pry off the back case. (See Fig. 3)
 2. Use the 2 supplied M4 × 25 machine screws for embedded mounting or M4 × 25 tapping screws for surface mounting to secure the remote controller back case. Prior to mounting, clear the cutouts in the back case corresponding to the holes in the wall box using a screwdriver or the like. Use the spacers and take care not to tighten the screws excessively. If the back case will not seat properly, cut the spacers to a suitable thickness.
 3. Connect locally supplied 3-core lead wires to the lead wires from the remote controller. (See “How to wire the remote controller.”)
(The remote controller will be damaged if 220/240V AC is applied.)
 4. Hook the remote controller to the tabs of the back case and mount it.

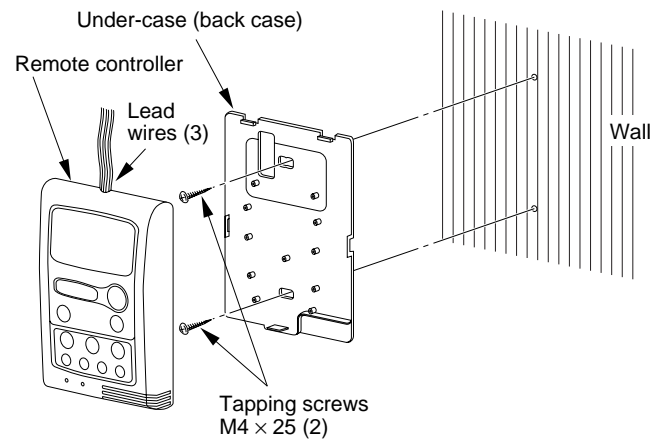
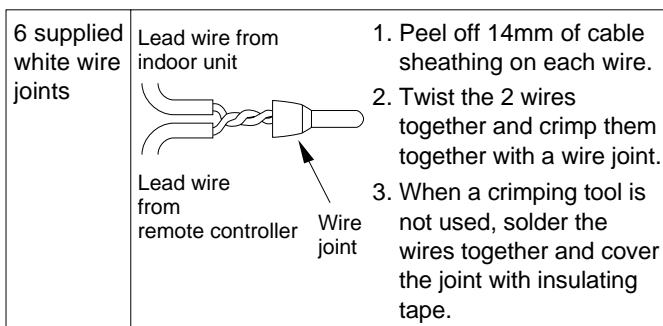

Fig. 2

■ How to wire the remote controller

● Connection diagram

See Fig. 4.



● How to connect the harness (supplied parts)

1. Turn off the power, and remove the grille.
2. Remove the screws of the electrical box and remove its cover.
3. Pull out the indoor unit controller (PCB ass'y). (Fig. 6 on next page)
4. Pull out the lead wire that connects the remote control receiver to CN11 of the controller (PCB ass'y). (Fig. 5 on next page)
5. Plug the socket of the supplied wire harness onto CN11.
6. Bind the wire harness and the inter-unit lead wires together, and route them. Fasten them under the electrical box with the clamp. Then, pull them out from the back of the indoor unit.
If required, connect the lead wire (field supply, max. 10 m). (Fig.4)
Use the supplied wire joints (6 pcs.) to connect the lead wire. (See the connection diagram as shown at right.)

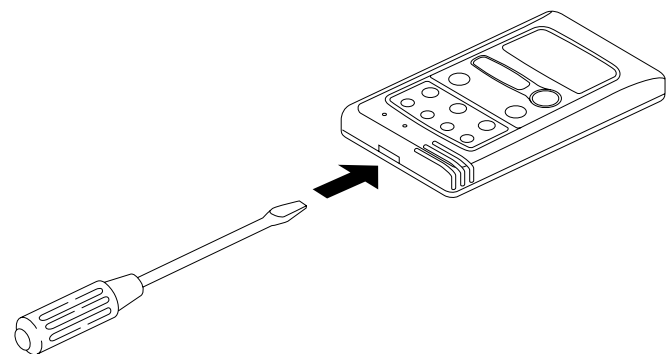
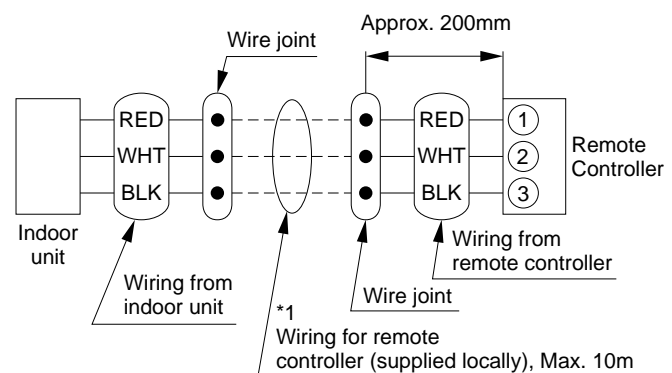

Fig. 3



*1: 0.5mm² to 2.0mm² wires are used for lead wires.

Fig. 4

• Electric Wiring Diagram

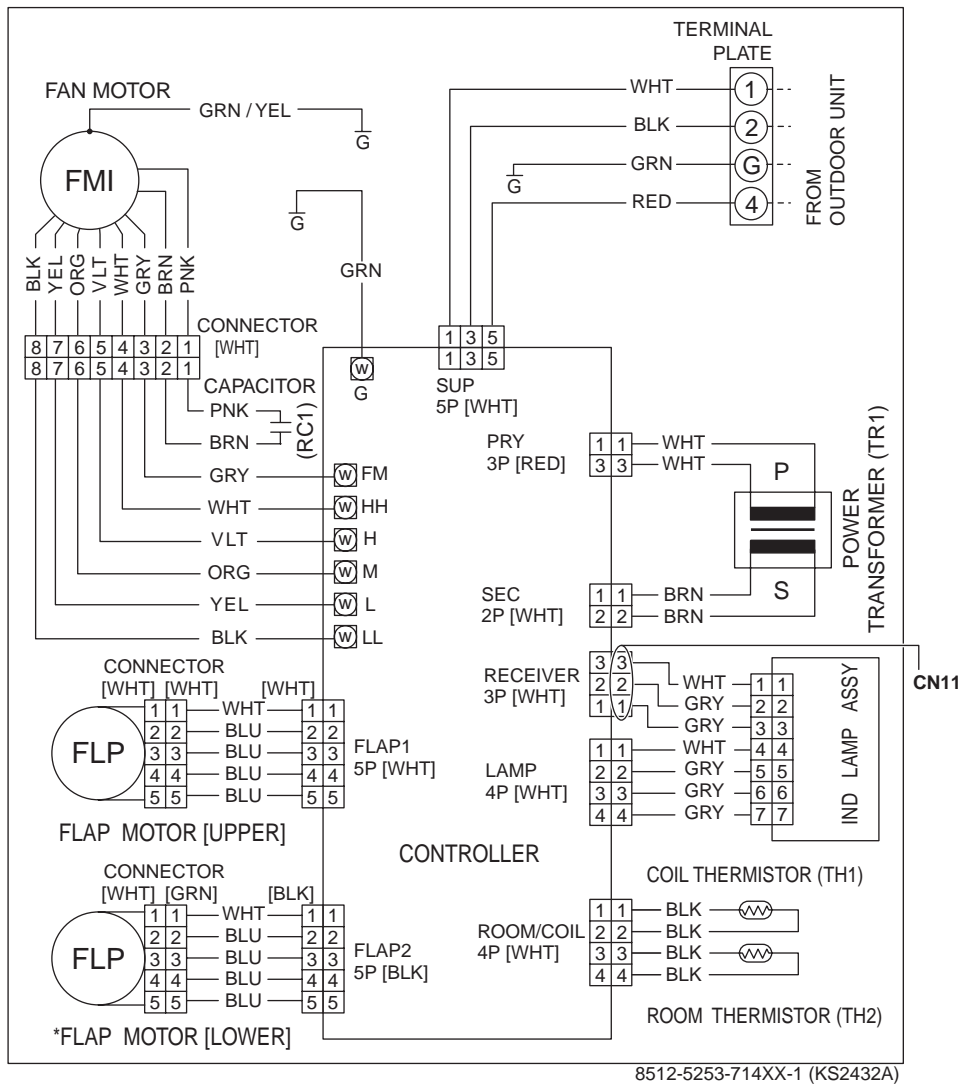

Fig. 5

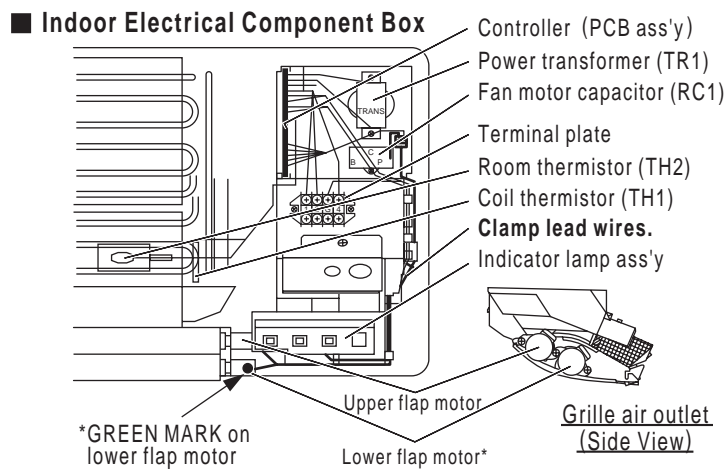

Fig. 6

■ How to test run the air conditioner

1. Switch on the power source.
2. Press the ON/OFF button on the remote control unit once.
3. Set the operation selector switch of the indoor unit to the TEST position. This starts the fan, producing uncooled forced air. (Fig. 7)
4. After 3 minutes, the system shifts into cooling operation, and cool air will start to be felt. Cooling operation with the switch at the TEST position is unaffected by the room temperature.
5. After stopping the test run, turn the operation selector switch of the indoor unit to the OFF position once, then move to ON position. (Fig. 7)
6. Press the ON/OFF button on the remote control unit to stop the air conditioner.

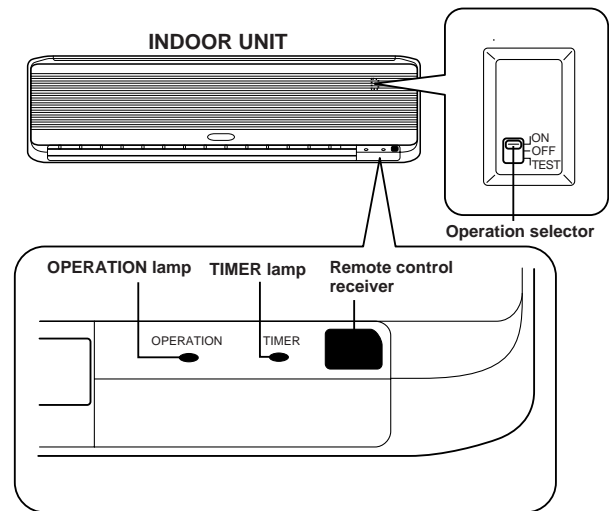

Fig. 7

NOTE

If the unit does not operate and the OPERATION lamp on the unit is blinking after going through the procedure, check the wiring between the units.